

COVER-PLAN VIEW

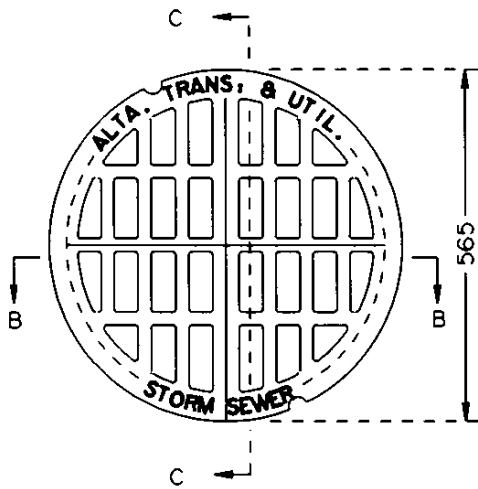

OPENING SIZES

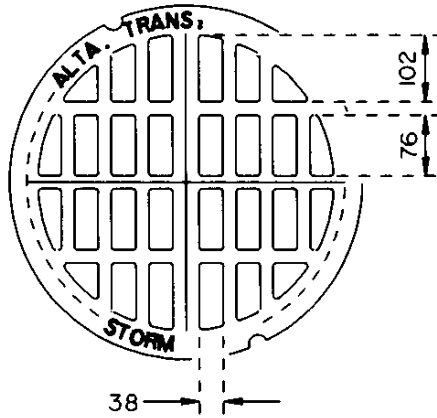

SECTION B-B

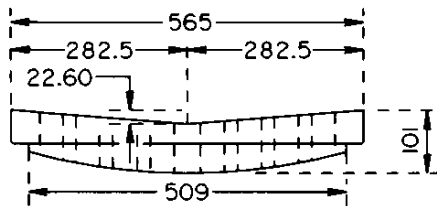

SECTION C-C

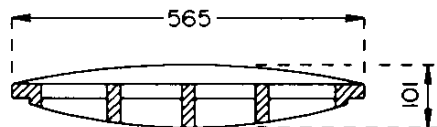

FRAME-PLAN VIEW

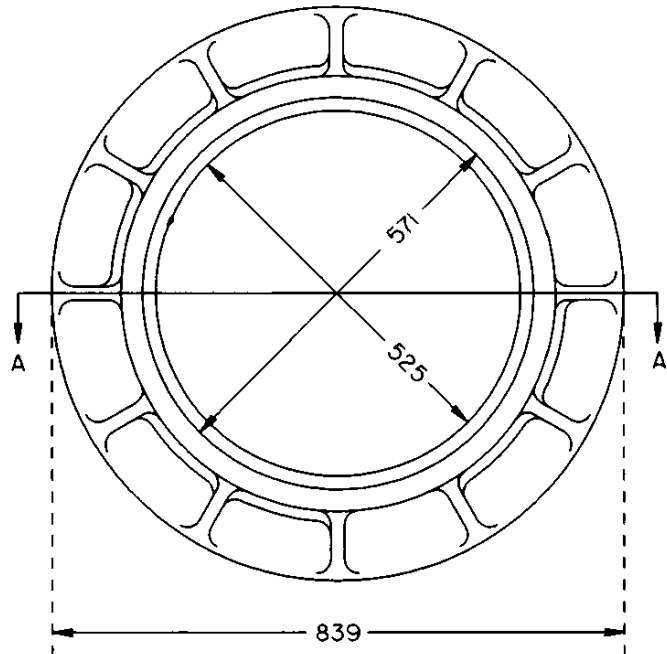

SECTION A-A

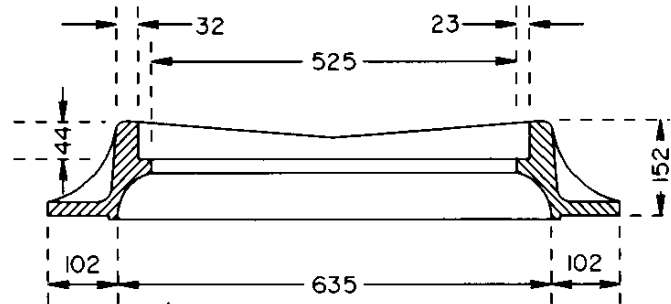

GRAPHICS FILE: cb6210m34.man

NOTES:

1. DIAGRAMS ARE BASED ON TYPE F-38 FOUNDRY CASTINGS.
2. NOMINAL DIMENSIONS IN mm.
3. THE LETTERING IS TO BE 'STANDARD RAISED CAST LETTERING' WITH 50mm SIZE LETTERS.

▲			
▲			
No.	REVISIONS	BY	DATE

<p style="text-align: center;">Approved:</p> <p style="text-align: center;"><i>Allan Kwan</i></p> <p style="text-align: center;">Executive Director Technical Standards Branch</p>	<p>Alberta</p> <p>TRANSPORTATION AND UTILITIES</p>
<p>Date: DECEMBER 4, 1995</p>	

**WHEELCHAIR RAMP
CATCH BASIN
MANHOLE COVER**

Prepared By: R.M.	Checked By: B.K.	Scale: N.T.S.	Dwg No: CB6-2.10M34
----------------------	---------------------	------------------	------------------------