

GUARDRAIL ELEVATION
1:20

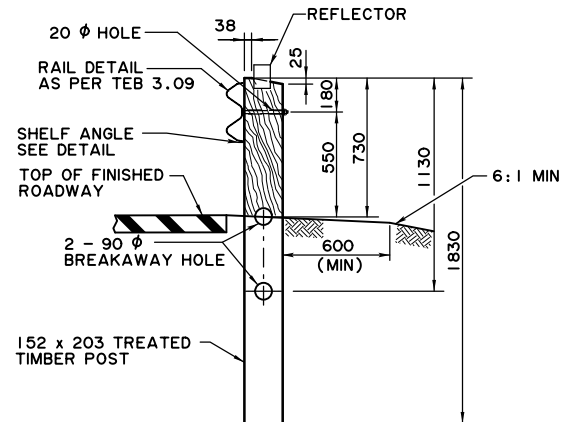

A SECTION

EDGE OF ROADWAY RADIUS (m)	RADIUS OF CURVED GUARDRAIL (m) - BASED ON 3.81m RAILS	NUMBER OF RAILS FOR CURVED SECTION (3.81m)	TOTAL NUMBER OF POSTS FOR CURVED SECTION	NUMBER OF APEX POSTS (POST WITH NO BLOCKOUT)
5	4.85	2	5	3
10	9.70	4	9	3
15	14.55	6	13	3
20	19.40	8	17	3
25	24.25	10	21	3

- NOTES:**
- DESIGN IS BASED ON CONCEPTS DEVELOPED BY WASHINGTON STATE DOT, FHWA, AND NZ TRANSPORT AGENCY. THIS SYSTEM HAS NOT BEEN CRASH TESTED TO NCHRP 350 OR MASH 2009 TL-3; THEREFORE, IT SHOULD ONLY BE USED WHERE OTHER SOLUTIONS ARE NOT PRACTICAL. DESIGNERS SHALL FIRST INVESTIGATE OTHER OPTIONS.
 - THIS DRAWING IS BASED ON A 15 m EDGE OF ROADWAY RADIUS, REFER TO TABLE FOR ADJUSTMENTS BASED ON OTHER RADII.
 - ALL RADII TO PROVIDE A MINIMUM CLEAR AREA OF 22 x 6 m FREE OF HAZARDS BEHIND THE GUARDRAIL.
 - CLEAR AREA BEHIND GUARDRAIL SHALL BE 6H:1V OR FLATTER AND MAINTAINED FREE OF NON-CRASHWORTHY OBSTRUCTIONS.
 - RAILS SHALL BE SHOP BENT TO THE SPECIFIED RADIUS FOR ALL CURVED GUARDRAIL ELEMENTS.
 - APPROACH GRADING SHALL BE 10H:1V OR FLATTER AND MAINTAINED FREE OF OBSTRUCTIONS.
 - A CRASHWORTHY END TREATMENT IN ACCORDANCE WITH NCHRP 350 OR MASH 2009 SHALL BE PROVIDED AT THE END OF THE GUARDRAIL ON THE MINOR ROAD AND MAY BE REQUIRED ON THE MAJOR ROAD.
 - CONTROLLED RELEASE TERMINAL (CRT) POST SHALL BE WOODEN POSTS.
 - NO BLOCKOUTS ON APEX POSTS. RAIL ON SHELF ANGLE AT CURVED APEX ONLY. NO BOLT THROUGH RAIL.
 - LAP ALL GUARDRAIL SECTIONS IN THE DIRECTION OF THE TRAFFIC FLOW.
 - REFLECTORS TO BE PLACED ON TOP OF APEX POSTS AND EVERY SIXTH POST UPSTREAM AND DOWNSTREAM FROM APEX.

ALL DIMENSIONS ARE IN MILLIMETRES UNLESS NOTED OTHERWISE

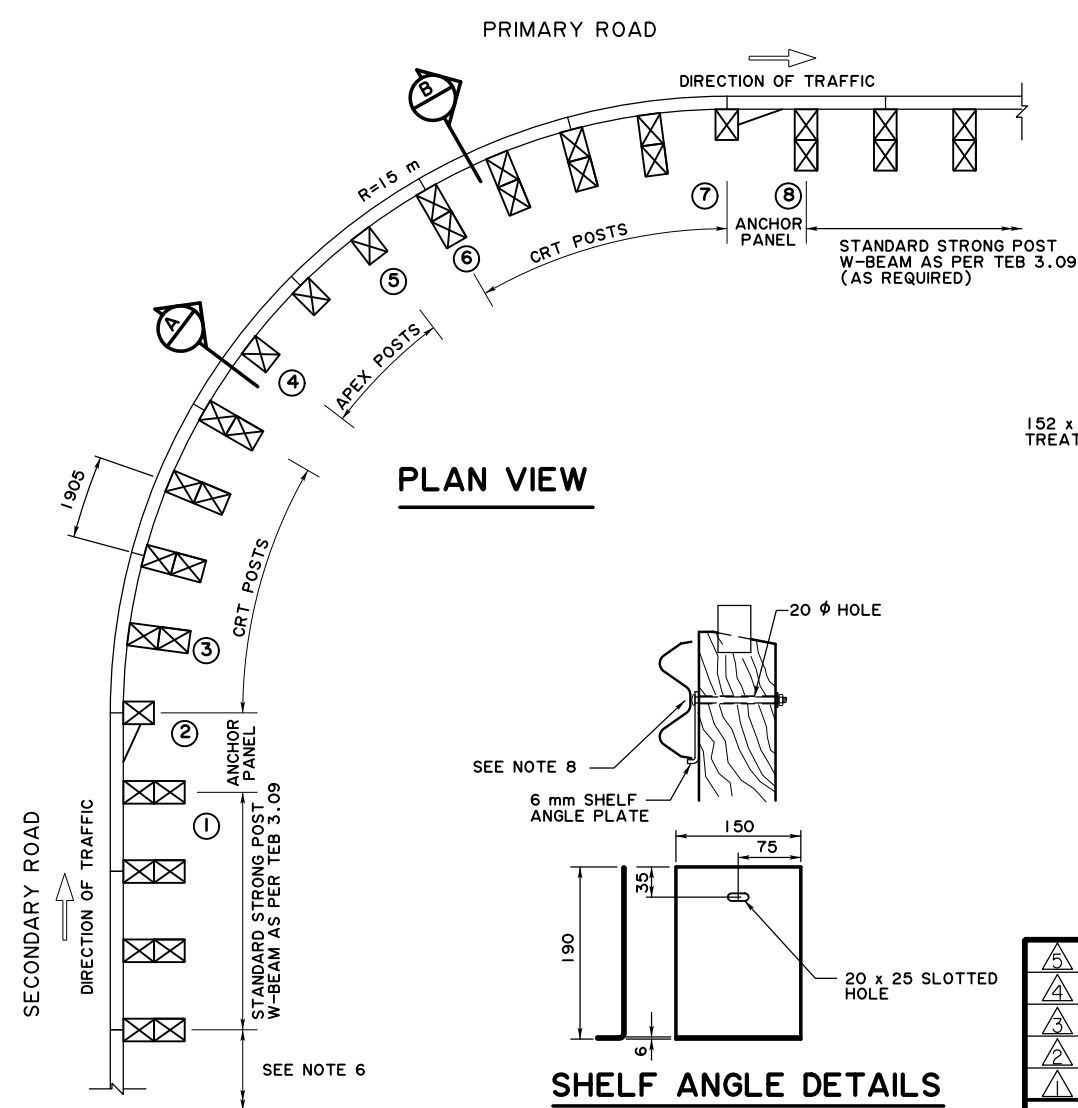

PLAN VIEW

SHELF ANGLE DETAILS

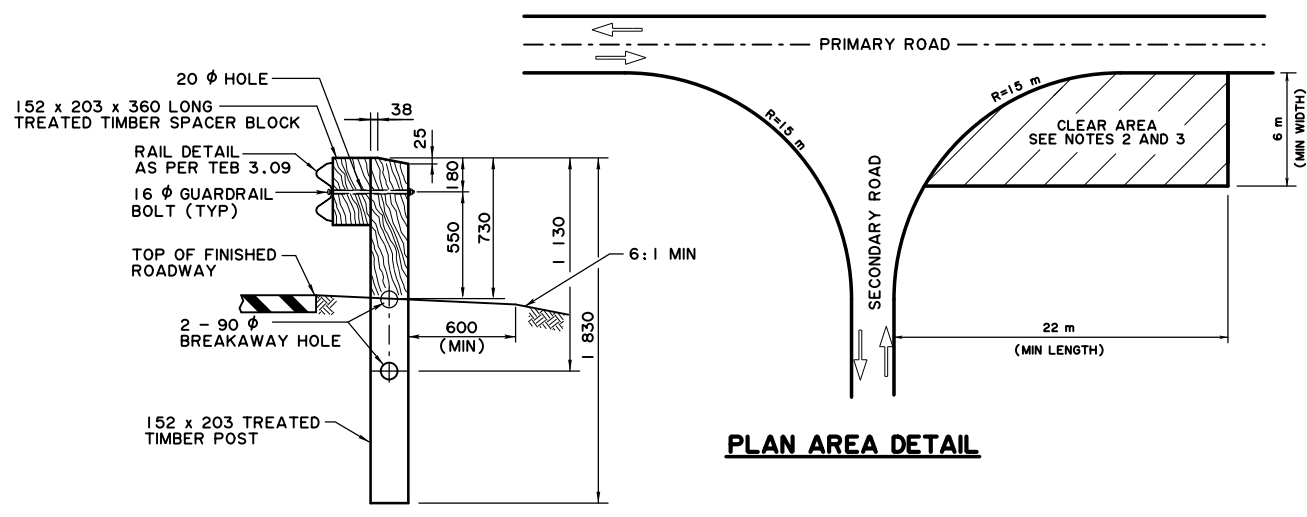

B SECTION

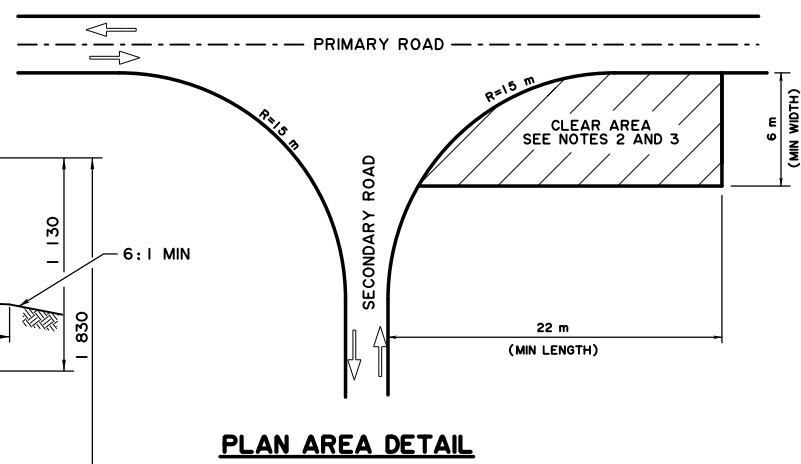

PLAN AREA DETAIL

REV	DATE	REVISION	BY
5			
4			
3			
2	2018-02-01	TITLE CHANGED, NOTES RENUMBERED	HT

 ORIGINAL SIGNED BY: D. WILLIAMSON EXECUTIVE DIRECTOR TECHNICAL SERVICES BRANCH		90 DEGREE SHORT RADIUS GUARDRAIL		DRAWING NO.	
				RDG-B1.13	
PREPARED BY	CHECKED BY	SCALE	DATE	APPENDIX B1	
GEC	BK	NTS	2018-01-08	H-APP-B1-34	