

**STANDARD SPECIFICATIONS  
FOR  
BRIDGE CONSTRUCTION**



~~**EDITION 15**~~

~~**2013**~~

**EDITION 16**

**2017**



# STANDARD SPECIFICATIONS FOR BRIDGE CONSTRUCTION

Prepared by:  
Bridge Engineering ~~Section~~  
Technical Services Branch  
Alberta Transportation  
Edmonton, Alberta

| Copyright ~~May, 2013~~April, 2017  
Her Majesty the Queen in right of Alberta, as represented by the Minister of  
Transportation

This Book, or parts thereof, may not be reproduced in any form without the written  
permission of

Executive Director, Technical Standards Branch  
Alberta Transportation

# STANDARD SPECIFICATIONS FOR BRIDGE CONSTRUCTION

## SUMMARY OF SPECIFICATIONSSECTIONS

<u>Sec No</u>	<u>Description</u>	<u>Section</u>	<u>Title</u>
1	Excavation.....		1 - 1
2	Backfill .....		2 - 1
3	Foundation Piles .....		3 - 1
4	Cast-In-Place Concrete.....		4 - 1
5	Reinforcing Steel.....		5 - 1
6	Structural Steel.....		6 - 1
7	Precast Concrete Units .....		7 - 1
8	Bridge Bearings.....		8 - 1
9	Drain <del>Trough</del> <u>Terminal Protection</u> <u>Troughs</u> .....		9 - 1
10	Heavy Rock Riprap .....		10 - 1
11	Ducts and <del>Voids</del> <u>Conduit</u> .....		11 - 1
12	Bridgerail.....		12 - 1
13	Miscellaneous Iron .....		13 - 1
14	Guardrail .....		14 - 1
15	Non-Skid Polymer Overlay .....		15 - 1
16	<del>Bridge Deck</del> Waterproofing .....		16 - 1
17	Asphalt Concrete Pavement.....		17 - 1
18	CSP and SPCSP Structures .....		18 - 1
19	Painted Roadway Markings.....		19 - 1
20	Deck Overlay and Concrete Rehabilitation.....		20 - 1
21	<del>Removal</del> <u>Demolition, Disposal</u> and Salvage of Bridge Structures.....		21 - 1
22	Painting .....		22 - 1
23	Structural Lumber and Piling .....		23 - 1
24	<u>Overhead</u> Sign Structures and Panels .....		24 - 1
25	Mechanically Stabilized Earth <del>Wall</del> <u>Walls</u> .....		25 - 1
26	RCP and PBC Structures.....		26 - 1



STANDARD SPECIFICATIONS FOR BRIDGE CONSTRUCTION

SECTION 1 EXCAVATION

TABLE OF CONTENTS

<b>1.1</b>	<b>General</b>	<b>1-1</b>
<b>1.2</b>	<b>Clearing</b>	<b>1-2</b>
<b>1.3</b>	<b>Culvert and Bridge Structure Foundations</b>	<b>1-2</b>
<b>1.4</b>	<b>Temporary Access Berms, Cofferdams and Dikes</b>	<b>1-3</b>
1.4.1	General	1-3
1.4.2	Pre and Post Construction Channel Surveys	1-4
1.4.3	Turbidity Monitoring and Testing	1-4
1.4.4	Fish Salvage	1-4
1.4.5	Cofferdam Dewatering	1-5
1.4.6	Cofferdam Bracing	1-5
1.4.7	Removal of Temporary Access Berms, Cofferdams and Dikes	1-5
1.4.8	Site Restoration	1-6
<b>1.5</b>	<b>Disposal</b>	<b>1-6</b>
<b>1.6</b>	<b>Measurement and Payment</b>	<b>1-6</b>
1.6.1	Excavation	1-6
1.6.1.1	Excavation Classification	1-6
1.6.1.2	Payment by Unit Price	1-7
1.6.1.3	Payment by Lump Sum	1-8
1.6.2	Temporary Access Berms, Cofferdams and Dikes	1-8





## 1.1 General

~~Excavation~~This specification is for the removal of all material, ~~of whatever nature,~~ necessary for the construction of ~~foundations, substructures or other works, in accordance with the drawings or~~Work as shown on the Drawings and as determined by the Consultant. Excavation shall also include ~~the construction of all cribs, cofferdams, dikes, berms or other devices necessary for the work, or necessary for,~~ but not be limited to, maintaining the stability of ~~adjacent headslopes~~slopes, fills, or existing structures; designing, constructing and maintaining temporary access berms, cofferdams and dikes; and the protection, care of water, dewatering and maintenance of ~~the excavated region~~excavations, and ~~the disposal of excavated material not required or not suitable for backfill as determined by the Consultant.~~ If any excavation or dredging is made at the site of the structure, the Contractor shall, without extra charge, after the foundation base is in place, backfill all such excavation to the original ground surface or river bed with material satisfactory to the Consultant. Material deposited within the stream area from foundation or other excavation, or from any other operations, shall be removed and the stream area freed from obstruction materials.

~~Where necessary, excavations shall be shored, braced or protected by cofferdams.~~ The Contractor shall maintain the integrity and stability of ~~existing headslopes and fill~~excavations at all times.

The Contractor shall provide acceptable provisions for the control and management of water and/or ice at all times.

Excavation elevations and dimensions shown on the Drawings shall be considered approximate only. The Consultant and the Department may require changes in final elevation and/or dimensions of excavations based on actual site conditions.

For projects in which the existing asphalt concrete pavement (ACP) surfaces are to be retained, the Contractor shall provide ~~suitable and adequate~~ protection acceptable to the Consultant of the ACP during excavation, trimming, or other construction activities. ~~Protection may include placement of filter fabric and sand or crushed granular material over the ACP.~~ Protection of the existing ACP will be considered to be incidental to the ~~work~~Work and no separate or additional payment will be made. Any damage to the ACP caused by the Contractor's operations shall be repaired at his expense and to the satisfaction of the Consultant.

## 1.2 Clearing

The Contractor shall backfill all excavations after foundation and substructure components are acceptably constructed to the design elevations shown on the Drawings and with materials acceptable to the Consultant. Where no design elevation is shown, the excavation shall be backfilled to the original ground surface or streambed, or as determined by the Consultant. Backfilling of excavations shall be completed and will be paid for in accordance with Section 2, Backfilling. All costs associated with excavations made by the Contractor that are not shown on the Drawings or required by the Consultant and the Department shall be backfilled at his expense to the satisfaction of the Consultant.

## **1.2 Clearing**

Clearing required for the completion of the Bridge/bridge structure Work will be considered incidental to the Work and no separate or additional payment will be made.

## **1.3—Depth of Footings**

~~The bottom of footing elevations shown on the drawings shall be considered as approximate only. The Department and Consultant may require changes in final dimensions or elevations of footings to establish a satisfactory foundation.~~

## **1.3 1.4—Preparation of Foundations—Culvert and Bridge Structure Foundations**

### **Excavated surfaces for Footings**

~~All rock or other hard foundation material culvert and bridge structure foundations shall be free of loose material, cleaned and cut to a firm surface as shown on the drawings. All seams condition acceptable to the Consultant. Seams contained within excavated surfaces shall be cleaned out and, filled, and compacted with ~~concrete, mortar or grout~~.~~

~~When concrete is to be cast on an excavated surface other than rock, special care shall be taken not to disturb the bottom of the excavation, and the final removal of the foundation material to grade shall not be made until just before the concrete is to be placed.~~

~~In the case of concrete culverts or certain spread footings, when a firm foundation is not attained at the grade established, the foundation shall be deepened to an elevation determined by the Department and materials acceptable to the Consultant and backfilled with suitable clay or granular material as described under Section 2, "Backfill".~~

~~In the case of spread footings, the lower part of the excavation, for a depth corresponding to the height of the footings, shall be made neat to the same plan dimensions and shape as the footing, and the concrete shall be placed without forms. Seepage water shall be collected and drained or pumped away before it can enter the neat portion of the excavation.~~

## **1.5—Cofferdams, Dikes and Berms**

### **1.5.1—General**

~~All cofferdams, dikes and berms for foundation construction shall be carried to adequate depths and heights, be safely designed and constructed of good standard materials, and be made as watertight as is necessary for the proper performance of the work which must be done inside them. Their dimensions shall give sufficient clearance for construction and inspection of forms and permit pumping of water outside of the forms.~~

~~No separate or additional payment will be made for the supply, construction or removal of cofferdams, dikes or berms. Full compensation for the cost of such material, equipment, tools, labour and incidentals shall be considered included in the price bid for the specified work to be carried out inside the cofferdam, dike or berm.~~

#### ~~1.5.2 Drawings Required~~

~~For substructure work, the Contractor shall submit drawings of the proposed cofferdam, shored excavation, dike or berm construction, and associated work procedures. The drawings and work procedures~~When excavated surfaces for culvert and bridge structure foundations are determined unacceptable by the Consultant, the Contractor shall continue the excavation to the elevation and dimensions determined by the Consultant and the Department. The excavation shall then be backfilled to the extents determined by the Consultant and the Department as shown on the Drawings and in accordance with Section 2, Backfill.

### **1.4 Temporary Access Berms, Cofferdams and Dikes**

#### 1.4.1 General

The Contractor shall design, construct, maintain and remove temporary access berms, cofferdams and dikes necessary to complete the Work.

The Contractor's design of temporary access berms, cofferdams and dikes shall include, but is not limited to, water and/or ice flows, height of temporary access berm, cofferdam and dike elevations, geometry, and materials.

Temporary access berms, cofferdams and dikes shall isolate instream construction activities and eliminate the flow of water through the construction area. The temporary access berms, cofferdams and dikes shall be installed and removed in a controlled manner to minimize the disturbance to the channel and banks.

The Contractor shall complete all Work in accordance with Subsection 1.2.50, Environmental Management, of the General Specifications. The Contractor's Environmental Construction Operations Plan (ECO Plan) shall include requirements for temporary access berms, cofferdams and dikes.

The Contractor shall establish a stream flow monitoring protocol that can provide several days advance warning of impending water and/or ice flows.

The Contractor shall test all temporary access berm and dike materials to confirm assumed design material properties. The Contractor shall provide material test reports to the Consultant upon request.

The Contractor shall submit design notes, drawings, construction sequencing, and an updated ECO plan, of proposed temporary access berms, cofferdams, and dikes to the Consultant for review and acceptance a minimum of 3 weeks prior to the commencement of the Work. The design notes, drawings and construction sequence shall be signed and sealed by a Professional Engineer, registered in the Province of Alberta.

The design notes, drawings shall, construction sequencing will be submitted reviewed by the Consultant solely to the Consultant two weeks prior to the commencement of the work for ascertain general conformance with Contract requirements. The Consultant's review and acceptance. The Consultant will review the drawings shall not be considered as to intent only, and any acceptance of such drawings by the Consultant shall in no way relieve relieving the Contractor of his full the responsibility for the work completing the Work in accordance with the Contract requirements.

#### 1.5.3 Concrete Seal

#### 1.4.2 Pre and Post Construction Channel Surveys

Prior to construction of temporary access berms and/or cofferdams, the Contractor shall complete a detailed elevation survey (3 m grid or finer) of the channel banks and streambed at all locations within the footprint of the access berm and cofferdam and a minimum distance beyond the footprint of 10 m on all sides where materials will be placed for the construction of the access berm and cofferdam. Additionally, the survey shall be completed at least 50 m downstream on the side of the channel banks and streambed where the access berm and cofferdam are to be located. The extent of the survey from the channel bank out into the channel shall extend a minimum of 10 m beyond the furthest projection into the channel of the access berm and cofferdam.

The channel banks and streambed shall be restored in accordance with Subsection 1.4.8, Site Restoration, prior to completing the post construction channel bank and streambed survey. The Contractor shall complete a post construction survey at the same locations as the pre construction survey within 5 days of restoration completion.

Pre and post construction survey results shall be submitted to the Consultant within 10 days of survey completion.

#### 1.4.3 Turbidity Monitoring and Testing

Turbidity monitoring and testing shall be carried out in accordance with the Special Provisions of the Contract.

#### 1.4.4 Fish Salvage

Fish salvage shall be carried out in accordance with the supplemental specifications of the Contract.

#### 1.4.5 Cofferdam Dewatering

Cofferdams shall be sealed to prevent the ingress of water. The Contractor shall make every attempt necessary to obtain a dry work area prior to commencement of foundation construction. The work area will be considered dry when the seepage rate is less than 500 mm in depth per hour and the water can be controlled by pumps or other means to reduce the depth of accumulated water to 75 mm in depth or less at the time of concrete placement. Dewatering cofferdams shall be completed using means and methods acceptable to the Consultant such that water does not flow through plastic concrete.

Seepage water removed from the cofferdam shall be managed in compliance with all environmental regulations by discharging it into settlement tanks or ponds, or other methods acceptable to the Consultant. A seepage water management strategy shall be included in the Contractor's ECO plan.

When conditions are encountered which in the opinion of the Consultant and the Department ~~and Consultant~~ make it impracticable to dewater the foundation cofferdam before placing concrete, ~~he may require or allow the~~ construction of a concrete foundation cofferdam seal below the elevation of the bottom of the foundation, ~~of such dimensions as may be necessary.~~ The foundation shall then be pumped out and the work completed in the dry. may be required. During the placing of ~~a foundation~~ the concrete cofferdam seal, the elevation of the water inside the cofferdam shall be controlled to prevent ~~any flow~~ water flowing through the concrete cofferdam seal ~~and if the cofferdam is to remain in place, it shall be vented or ported at low water level.~~ No separate or additional payment will be made for ~~construction of~~ the concrete cofferdam seal unless it is specified on the ~~drawings~~ Drawings, in which case it will be paid for at the unit price bid for the class of concrete specified.

#### ~~1.5.4 Removal of Bracing~~

#### 1.4.6 Cofferdam Bracing

No ~~timber or cofferdam~~ bracing shall be left in the ~~cofferdams in such a way as to extend into the substructure concrete, completed Work~~ without the written ~~permission~~ acceptance of the Consultant and the Department ~~and Consultant~~.

#### ~~1.1.11.4.7~~ Removal of Cofferdams, Dikes and Temporary Access Berms, Cofferdams and Dikes

~~Cofferdams, Temporary access berms, cofferdams, and~~ dikes and berms shall be removed after completion of the Work ~~for which they were installed and in accordance with the Special Provisions of the Contract.~~ The Contractor shall take care not to disturb or damage the finished works completed Work in any way during removal operations. Backfill required around the permanent completed work shall be placed prior to removal of the temporary access berms, cofferdams, and ~~dikes or berms.~~

~~The Consultant reserves the right to require the Contractor to remove all materials from the streambed at any time to prevent stream pollution or adverse environmental effects, including bank erosion, or effects on adjacent structures or any other installations or property. If the Contractor fails to comply with this requirement, the Department and Consultant further reserves the right to make immediate separate arrangements to remove such materials at the Contractor's expense. The Contractor shall be responsible for all costs incurred by the Department and Consultant to remove such material and/or all damages incurred.~~

#### 1.4.8 ~~1.6~~ Inspection of Excavation Site Restoration

~~Upon removal of temporary access berms, cofferdams and dikes, the channel banks, streambed, and any areas disturbed from the construction of access roads shall be restored to the composition and elevation that existed at the time prior to construction and the pre construction channel survey and in accordance with the Drawings. Site restoration will be reviewed and accepted by the Consultant based on comparison of pre and post construction channel surveys and any other available information.~~

#### 1.5 Disposal

~~Details of proposed excavated material disposal locations shall be submitted to the Consultant for review and acceptance prior to disposing of materials.~~

#### 1.6 Measurement and Payment

##### Excavation

~~After the excavation is completed to the elevation shown on the drawings, the Contractor shall notify the Consultant. The Consultant shall review and accept the depth of the excavation and the character of the foundation material before any further work proceeds.~~

~~The Consultant may require test pits, test drilling, further excavation, or other work as necessary to obtain an acceptable excavation.~~

~~Test pits and test drilling shall be paid for in accordance with 1.2.25 "Extra Work" of the General Specifications.~~

##### 1.6.1

#### ~~1.7~~

##### 1.6.1.1 Excavation Classification ~~of~~

##### Excavation

~~Excavation shall~~ will be classified as follows:

Structural Excavation—: Excavation related to the foundations and substructures, substructure components; or

Channel Excavation—: Excavation carried out to improve the alignment or carrying capacity of the stream channel.

### ~~1.8 Measurement and Payment~~

~~Payment~~ Payment for Excavation structural and channel excavation will be either at the unit price bid per cubic metre or lump sum price basis. Such price ~~The prices bid shall include the cost of all labour, material, equipment, and other items of expense necessary for the successful completion of the excavation to complete the Work.~~

Payment ~~will be determined as follows:~~

#### ~~1.1.1.1~~ 1.6.1.2 ~~by~~ Unit Price per Cubic Metre

~~When Measurement for payment is to be on unit price basis, the quantity to be paid for will be the actual number of cubic metres in the natural condition, of excavation will be by the cubic metre of material acceptably excavated in conformity with the drawings or as determined by the Consultant. No, measured to the nearest cubic metre.~~

~~The quantity of excavation will be included in the measurement for payment which is outside the neat lines of the footing. The top and bottom limits of the computed volume shall be material paid for will be the actual volume of material excavated and placed or disposed of, as measured from the original ground surface and or streambed to the bottom of neat lines shown on the completed footing, with no payment to Drawings as determined by the Consultant.~~

~~Payment will be included made at the unit prices bid for the removal of water~~ “Excavation - Structural” and/or “Excavation - Channel”, as applicable, and ice.

#### ~~1.8.2~~ Lump Sum Price

~~When payment is to will be on lump sum price basis, the lump sum price shall include full payment compensation for the excavation of all material labour, equipment, tools and incidentals necessary in conformity with to complete the Work as shown on the Drawings and to the drawings or as determined by satisfaction of the Consultant.~~

~~When it is necessary, in the opinion of the Department and Consultant, to carry the foundations below the elevations;~~

All cost associated with the control and management of water and/or ice will be considered incidental to the Work, and no separate or additional payment will be made.

All costs associated with maintaining the stability of slopes, fills, or existing structures will be considered incidental to the Work, and no separate or additional payment will be made.

1.6.1.3 Payment by Lump Sum

Payment will be made at the lump sum prices bid for “Excavation - Structural” and/or “Excavation - Channel”, as applicable, and will be full compensation for all labour, equipment, tools and incidentals necessary to complete the Work as shown on the drawings, the additional quantity of excavation will be paid by Drawings and to the satisfaction of the Consultant.

When the required extents of excavation are greater than originally anticipated, as determined by the Consultant and the Department, the additional quantities of excavation may be paid for through a negotiated lump sum price, or as Extra Work in accordance with Specification 1.2-25 “Extra Work”, General Specifications, of the General Specifications as determined by the Department and Consultant, Specification Amendments and Supplemental Specifications for Highway and Bridge Construction.

All cost associated with the control and management of water and/or ice will be considered incidental to the Work, and no separate or additional payment will be made.

All costs associated with maintaining the stability of slopes, fills, or existing structures will be considered incidental to the Work, and no separate or additional payment will be made.

1.6.2 Temporary Access Berms, Cofferdams and Dikes

Payment will be made at the lump sum price bid for “Temporary Access Berms, Cofferdams and Dikes”, and will be full compensation for the design; construction; maintenance, including the control and management of water; removal; site restoration; and all labour, materials, equipment, tools and incidentals necessary to complete the Work to the satisfaction of the Consultant.

All costs associated with pre and post construction channel surveys, and excavation through the depth of the berm to access the Work, including structural excavation, will be considered incidental to the Work, and no separate or additional payment will be made.



STANDARD SPECIFICATIONS FOR BRIDGE CONSTRUCTION

SECTION 2 BACKFILL

TABLE OF CONTENTS

<b>2.1</b>	<b>General</b> .....	<b>2-1</b>
<b>2.2</b>	<b>Materials</b> .....	<b>2-1</b>
2.2.1	Compacted Non-Granular Material.....	2-1
2.2.2	Crushed Aggregate Material .....	2-2
2.2.3	Backfill Material Tests .....	2-3
<b>2.3</b>	<b>Placement</b> .....	<b>2-7</b>
<b>2.4</b>	<b>Measurement and Payment</b> .....	<b>2-8</b>
2.4.1	Payment by Unit Price.....	2-8
2.4.2	Payment by Lump Sum.....	2-8



## 2.1 General

~~Backfill shall include material required to fill excavations adjacent to various bridge components or culvert installations. Backfill shall also include This specification is for the supply and placingplacement of backfill materials necessary for construction ofto complete the Work, including but not limited to, filling excavations; constructing approach fills, roadway embankments, and slopes, and channel banks, and berms as shown on the Drawings and as determined by the Consultant.~~

All materials shall be sourced and supplied by the Contractor. The Contractor shall be responsible for royalties, processing, loading, hauling, placing, compacting, ~~QC~~quality control testing and any other incidentals required to supply these materials in place.

## 2.2 ~~2.2~~ Materials

All material used for backfill, including native material, shall be of a quality acceptable to the Consultant and shall be in a thawed state when placing and compacting and be free from rocks, large or frozen lumps, wood, or other unsuitable material. No backfill material will be permitted to be placed on frozen substrate.

### 2.2.1 ~~2.2.1~~ Compacted Non-Granular Material

Compacted non-granular material shall be inorganic soil such as clay. When reviewed and accepted by the Consultant and the Department, non-granular material can be substituted with granularcrushed aggregate material.

~~Material used for the construction of the "Culvert clay seals" shall be highly plastic clay. Material with high swelling potential such as bentonite clays will not be permitted. When the proposed material characteristics for clay seals are questionable the Consultant will require the Contractor to classify the material using Test Methoddefined by ASTM D2487, Classification of Soils for Engineering Purposes. Material shall and have a minimum Plasticity Index of 40.~~

2.2.2 ~~2.2.2—Gravel Material and~~Crushed Aggregate Material

Where ~~Gravel Material or~~ crushed aggregate material is specified, it shall consist of clean sand and gravel, complying with the ~~following requirements:~~requirement of Table 2-1, Crushed Aggregate Material Requirements.

**Designation/Class**

Des 2 Class 25 crush aggregate material can be used where Des 2 Class 40 has been specified. No separate or additional payment will be considered for the proposed substitution.

**Table 2-1: Crushed Aggregate Material Requirements**

Metric Sieve Size (CGSB 8 -GP -2M) ( $\mu\text{m}$ )	*Gravel Material Des 6 Class 80	Crushed Aggregate Material Des 2 Class 40 (% Passing)	Crushed Aggregate Material Des 2 Class 25 (% Passing)
Sieve Size	Percent	Percent	Percent
$\mu\text{m}$	Passing	Passing	Passing
125-000	--	--	

	<b>80 000</b>		<b>100</b>	<b><del>--100</del></b>
	50 000		<del>55</del> -100	<del>--100</del>
	40 000		<del>--100</del>	100
	25 000	<del>38</del> -100	70 - 94	100
	20 000		<del>--n/a</del>	--
	16 000	<del>32</del> -85	55 - 85	70 - 94
	10 000	--	44 - 74	52 - 79
	5 000	<del>20</del> -65	32 - 62	35 - 64
	1 250	--	17 - 43	18 - 43
	630	--	12 - 34	12 - 34
	315	<del>6</del> -30	8 - 26	8 - 26
	160	--	5 - 18	5 - 18
	80		2 - 10	2 - 10
				<del>--2</del> -10
% fractures by weight (2 faces)		<del>N/A</del>	50+	60+
Plasticity Index		<del>NP-8</del>	NP - 6	NP - 6
L.A. Abrasion Loss Percent Maximum		<del>N/A</del>	50	50

~~\*Note: Native Gravel Material may require processing in order to meet the gradation requirements.~~

### 2.2.3 ~~2.2.3~~ Backfill Material Tests

~~The Contractor shall be responsible for carrying out quality control testing at the frequencies specified in Table 2-2, Quality Control Testing Requirements. Testing shall be completed by an independent third party testing agency that is prequalified by the Department in the category of QA Testing Services (Grading, Base Paving).~~

~~The Contractor shall submit for the Consultant's sieve analysis, percent fracture, laboratory/proctor density, plasticity index testing for the applicable proposed backfill materials to the Consultant for review two and acceptance 2 weeks before placing of the granular material, a sieve analysis representing the material to be used at site prior to commencement of the Work. Sampling and testing shall have been done completed no more than 90 days prior to usage unless otherwise approved by the Consultant. For non-granular material, the source and material shall be approved reviewed and accepted by the Consultant two weeks prior to usage.~~

~~The Contractor shall be responsible for all costs associated to carry out the appropriate testing procedures to confirm specification requirements. The Contractor shall use professional engineering services and a qualified testing firm licensed in the Province of Alberta for all quality control work associated with backfilling procedures.~~

~~The Contractor shall be fully responsible for production of aggregate that meets all the specification requirements. Des 2 Class 25 Crushed Aggregate material can be used where Des 2 Class 40 material has been specified at no separate or additional cost to the Department.~~

~~Results of all quality control tests shall be submitted to the Consultant within 3 days of the test being completed.~~

~~Unless otherwise specified, the latest edition of the following standard Alberta Transportation Test methods (ATT) shall be used to determine material characteristics.~~

~~Test methods and minimum frequencies shall be as shown in Table 2.2.3 Quality Control Testing Requirements.~~

Table 2-2.3

**Quality Control Testing Requirements**

Description	Standard	Minimum Frequency
<b>Aggregates Tests</b>		
<u>Sieve Analysis</u>		
<del>1.</del> Crushed Aggregate	ATT-25 or ATT-26	One per Source
<del>2.</del> Gravel Material	ATT-25	<del>One per Source</del>

<u>Plasticity Index</u>	AASHTO T90	When requested by the Consultant
<u>Percent Fracture</u> (crushed aggregate)	ATT-50	One per Source
<u>L.A. Abrasion</u>	AASHTO T96	When requested by the Consultant
<b>Backfill Tests</b>		
<u>Moisture Density Tests (Laboratory/Proctor)</u>		
<del>1.</del> Crushed Aggregate (Des 2 Class 25)	ASTM D698	One test per source
<del>2.</del> Non Granular Material (Soil)	ASTM D698	One test for each soil type
<u>Density of Materials (In-place/Field)</u>		
<del>1.</del> Crushed Aggregate (Des 2 Class 25) <del>or</del> <del>—(Des 2 Class 20)*</del>	ASTM D6938  ATT 8 or 9	<del>Three tests on Culvert Bedding taken at invert level</del>  <del>Three</del> For culvert and bridge component backfill – 3 tests for: <u>the first lift of backfill, every <del>four</del>4 lifts of backfill thereafter, and the final lift.</u>
<del>2.</del> Crushed Aggregate (Des 2 Class 40 <del>or Gravel</del> Material)	ATT-58A (Control Strip Method)	<del>For Culverts, control</del> Control strips shall be established on top lift of bedding material at invert level <u>for culverts and bridge components on the first lift of backfill material for each Bridge Component</u>  <del>For Culverts, control re-</del> and at the $\frac{1}{4}$ and $\frac{1}{2}$ height of the required backfill depth. <u>For culverts, the controls strips shall be established on each side both sides of culvert at the <math>\frac{1}{3}</math> and mid-point of culvert backfill, and the mid-point of backfill for each Bridge Component</u>  <del>Monitor for minimum number of passes on all other lifts</del> <u>the pipe.</u>



<del>3-Non-Granular</del> Material (Soil)	ASTM D6938  ATT 8 or 9g	<del>Embankment – Three tests per 2-m height of embankment, each side</del>  <del>One test on clay seal at each end of Culvert</del> For embankments and bridge components – 3 tests for: <u>the first lift of backfill, every 10 lifts thereafter, and the final lift.</u>
		For culvert clay seals – 3 tests for: <u>the first lift of backfill, every 4 lifts thereafter, and the final lift.</u>

\* At the Contractor's option, Notes:

- (1) ~~ATT-58A (Control Strip Method) can~~ may be used for field density testing of Des 2 Class 25 or Des 2 Class 20 crushed aggregate material when reviewed and accepted by the Consultant.
- (2) Location of density testing shall be reviewed and accepted by the Consultant.
- (3) Compaction monitoring shall occur on all lifts of backfill.

Results of all quality control tests shall be submitted to the Consultant within 3 days of the test being completed. **2.3 Placing**

### 2.3 Placement

All spaces excavated and not occupied by the permanent Work shall be backfilled with and compacted with material up acceptable to the elevation indicated on the drawings or determined by the Department and Consultant. Compacted material may also be required in other locations as and to the design elevations shown on the Drawings or as required by the Department and determined by the Consultant. Where no design elevation is shown, the excavation shall be backfilled to the original ground surface or streambed, or as determined by the Consultant.

All backfill material, regardless of type shall be placed in lifts not exceeding 150 mm in thickness of loose material, ~~and each lift shall be mechanically tamped with pneumatic tampers or and approved equivalent.~~ The rate of placing the backfill material shall be such that the ~~tamper can compact thoroughly and~~ specified level of compaction is achieved uniformly. Compaction of crushed aggregate (~~Des 2 Class 25~~) and non-Granular Material (Soil) ~~granular material~~ shall be a minimum of 95% proctor density with optimum moisture content. ~~Compaction acceptance of Gravel Material and Crushed Aggregate (Des 2 Class 40) shall be done using the Control Strip Method with a Nuclear Gauge.~~

~~On projects where Control Strips are being established,~~ The compaction equipment proposed by the Contractor must be reviewed and accepted by the Consultant prior to commencement of the Work.

Compaction acceptance testing shall be completed in accordance with Table 2-2: Quality Control Requirements.

Backfill material shall not be placed against any concrete ~~abutment, wingwall or culvert component~~ until ~~permission has been given by the Consultant, has reviewed and accepted the timing of placement.~~ Generally, backfill placement will not proceed be permitted until ~~the 7 days after concrete has been in place at least 7 days placement~~ or the compressive strength of the concrete ~~is has obtained~~ 75% of the required 28 day strength.

Backfill material around culverts and concrete ~~elements components~~ shall be placed simultaneously on ~~both~~ sides ~~to of~~ the ~~same culvert or concrete component.~~ The elevation ~~to avoid unbalanced loading~~ difference on any side shall not exceed 300 mm. Special precautions shall be taken to prevent any wedging action against the concrete and the slope bounding the excavation for abutments and wingwalls. The slope shall be stepped to prevent wedge action. Jetting of backfill material behind abutments and wingwalls will not be permitted.

The Consultant ~~may will~~ carry out quality assurance testing, if the Contractor's compaction methods and procedures are in the Consultant's opinion not meeting the specification requirements.

## **2.4—Measurement and Payment**

### **2.4 Payment**

#### 2.4.1 Payment by Unit Price

Measurement for **Backfill** payment of the type(s) specified backfill will be by the cubic metre of material acceptably placed and compacted, measured to the nearest cubic metre.

The quantity of backfill to be paid for will be the actual measured quantity of backfill acceptably placed and compacted as shown on the Drawings and to the satisfaction of the Consultant.

Payment will be made at the unit price ~~bid per cubic metre or lump sum price bid.~~ The price bid shall include the cost for or prices bid for "Backfill", for the types of material specified, and will be full compensation for the supply of material; placement and compaction; sampling and testing; and all labour, ~~material~~ materials, equipment, tools, and incidentals necessary to complete the Work as shown on the Drawings and to the satisfaction of the Consultant.

#### 2.4.1—Unit Price per Cubic Metre

#### 2.4.2 Payment by Lump Sum

Payment will be made at the lump sum price or prices bid for "Backfill", for the types of material specified, and will be full compensation for the supply of material; placement and compaction; sampling and testing; and all labour, materials, equipment, tools and incidentals necessary to complete the Work as shown on the Drawings and to the satisfaction of the Consultant.

~~When the Unit Price Schedule contains unit price bid for this work, payment will be made for the quantity of compacted **Backfill** incorporated in the work based on the dimensions and elevations indicated on the drawings or as determined by required extents of excavation are greater than originally anticipated, as determined by the Consultant and the Department and Consultant. The quantity will be determined by measuring the volume of the excavation.~~

#### ~~2.4.2 Lump Sum Price~~

~~When the Unit Price Schedule contains lump sum price bid for this work, payment will be made for the compacted **Backfill** of all structural excavations and other areas shown on the drawings.~~

~~When excavations are taken below specified elevations at the Department and Consultant's request, the additional quantities of backfill quantity will may be paid by for through a negotiated lump sum price, or as Extra Work in accordance with Specification 1.2.25 "Extra Work" of the General Specifications as determined by the Consultant, of the General Specifications, Specification Amendments and Supplemental Specifications for Highway and Bridge Construction.~~



# STANDARD SPECIFICATIONS FOR BRIDGE CONSTRUCTION

## SECTION 3 FOUNDATION PILES

### TABLE OF CONTENTS

<b>3.1</b>	<b>General</b> .....	<b>3-1</b>
<b>3.2</b>	<b>Materials</b> .....	<b>3-1</b>
3.2.1	Steel Piling.....	3-1
3.2.1.1	Mill Test Reports.....	3-1
3.2.1.2	Galvanizing.....	3-2
3.2.2	Timber Piling.....	3-2
3.2.3	Pile Concrete.....	3-2
3.2.4	Reinforcing Steel.....	3-2
<b>3.3</b>	<b>Handling</b> .....	<b>3-2</b>
<b>3.4</b>	<b>Driven Piles</b> .....	<b>3-3</b>
3.4.1	Pile Driving Equipment.....	3-3
3.4.2	Pile Driving Plan.....	3-4
3.4.3	Driven Pile Installation.....	3-4
3.4.3.1	Pile Driving Set Criteria and Tip Elevation Requirements.....	3-4
3.4.3.1.1	Bearing Formulas.....	3-6
3.4.3.2	Steel Piling.....	3-8
3.4.3.3	Steel Piling Splices.....	3-9
3.4.3.4	Testing of Steel Piling Splices.....	3-9
3.4.3.5	Reinforcing Steel.....	3-10
3.4.3.6	Pile Concrete.....	3-11
3.4.3.7	Timber Piles.....	3-11
3.4.3.8	Driven Pile Installation Tolerances.....	3-12
3.4.4	Defective Piles.....	3-12
<b>3.5</b>	<b>Drilled Cast-In-Place Concrete Piles</b> .....	<b>3-13</b>
3.5.1	Pile Drilling Equipment.....	3-15
3.5.2	Pile Drilling Plan.....	3-15
3.5.3	Drilled Pile Installation.....	3-16
3.5.3.1	Open Drilled Holes.....	3-17
3.5.3.2	Reinforcing Steel.....	3-17
3.5.3.3	Pile Concrete.....	3-18
3.5.3.3.1	Pile Concrete Placed in the Dry.....	3-18
3.5.3.3.2	Pile Concrete Placed under Water.....	3-19
3.5.3.3.3	Crosshole Sonic Logging.....	3-19
3.5.3.4	Cold Weather Conditions.....	3-21
3.5.3.5	Drilled Pile Installation Tolerances.....	3-21
3.5.4	Drilled Pile Capacity.....	3-22
3.5.5	Defective Piles.....	3-22
<b>3.6</b>	<b>Pile Capacity Testing and Reporting</b> .....	<b>3-22</b>
3.6.1	Static Load Testing.....	3-22

3.6.2	High Strain Dynamic Load Testing - Pile Driving Analysis (PDA Testing)....	3-23
3.6.2.1	Testing Requirements.....	3-23
3.6.2.2	Reporting Requirements.....	3-24
<b>3.7</b>	<b>Measurement and Payment.....</b>	<b>3-25</b>
3.7.1	Driven Piles.....	3-25
3.7.1.1	Supply of Piling.....	3-25
3.7.1.2	Pile Set-up.....	3-25
3.7.1.3	Pile Driving.....	3-25
3.7.1.4	Pile Tip Reinforcement.....	3-26
3.7.1.5	Pile Splicing.....	3-26
3.7.1.6	Restocking of Piling.....	3-26
3.7.1.7	Pile Concrete.....	3-26
3.7.1.8	Reinforcing Steel.....	3-27
3.7.2	Drilled Cast-In-Place Concrete Piles.....	3-27
3.7.2.1	Drill Rig Set-up.....	3-27
3.7.2.2	Pile Installation.....	3-27
3.7.2.3	Pile Concrete.....	3-27
3.7.2.4	Reinforcing Steel.....	3-28
3.7.3	Static Load Testing.....	3-28
3.7.4	PDA Testing.....	3-28

### 3.1 General

This specification is for the supply and installation of plain and galvanized steel H-piles and pipe piles, timber piles, ~~precast concrete piles,~~ and cast-in-place concrete piles. It includes driven piles, drilled cast-in-place concrete piles, ~~and~~ drilled cast-in-place concrete/steel pipe composite piles, and associated pile capacity test methods.

#### ~~3.1.3.2~~ 3.2 ~~Materials~~

##### ~~3.1.13.2.1~~ 3.2.1 ~~Steel "H" Piling~~

Steel "H" piling shall meet the requirements of ~~Specification~~ ASTM A36 or CSA G40.21M 350W. ~~Where piling is designated in metric dimensions, imperial equivalent piling will be accepted. Mill certificates shall be provided to the Consultant for review and acceptance prior to pile installation.~~

~~Splice plates shall be fabricated to the dimensions shown on Standard Drawing S-1415 "Standard H-Pile Splice".~~

##### ~~3.2.2~~ Steel Pipe Piling

Steel pipe piling shall meet the requirements of ~~Specification~~ ASTM 252 Grade 2, except that hydrostatic testing is not required. ~~Although~~

The boron content of steel piling shall not exceed 0.0008%.

Where metric dimensioned piling is specified, imperial dimensioned piling is designated in metric dimensions, may be proposed and submitted to the Consultant for review and acceptance. At a minimum, the proposed imperial dimensioned piling shall have equivalent piling will be acceptable. or greater section properties.

##### 3.2.1.1 Mill Test Reports

Mill ~~certificate~~test reports shall be provided for all foundation pile components in English.

Mill test reports shall be submitted to the Consultant for review and acceptance 2 weeks prior to pile installation. Some out-of-roundness commencement of the pipe is acceptable provided an acceptable splice can be completed.Work.

Where mill test reports originate from a mill outside Canada or the United States of America, the Contractor shall have mill test reports verified by a certified laboratory in Canada by testing the material to the specified material standards, including boron content. The testing laboratory shall be certified to ISO/IEC 17025 by an organization accredited by the Standards Council of Canada for the tests required. Samples for testing shall be collected by personnel employed by the certified laboratory. A verification letter shall be provided by the certified laboratory that includes at a minimum, the applicable mill test reports, testing standards, date of verification testing, and declaration of material compliance with Contract requirements. The verification letter shall be signed by an authorized officer of the certified laboratory.

3.2.1.2 Galvanizing

Galvanized piling shall be galvanized ~~by the hot dip method,~~ in accordance with ~~the current edition of the ASTM A123/A123M Standard Specification for Zinc (Hot-Dip Galvanized) Coatings on Iron and Steel Products~~Subsection 6.2.7.3, Galvanizing.

~~Splice backup rings and closed pipe pile end plates shall be fabricated as shown on Standard Drawing S-1414 "Standard Pipe Pile Splice" and Standard Drawing 1479 "Standard Closed Pipe Pile End Plate".~~

~~3.1.23.2.2~~ 3.2.3 Timber Piling

Treated timber piling shall be fir or pine, and untreated timber piling shall be fir, spruce, pine or a species ~~that is equivalent or better as determined by the Consultant. Timber piling shall conform to Section 23 "Dimensional Structural Lumber and Piling", and shall be of the length specified on the drawings~~acceptable to the Department and the Consultant.

Timber ~~splice~~piling shall conform to Section 23, Dimensional Structural Lumber and Piling, and shall be fabricated as shown of the length specified on Standard Drawing S-1413 "Standard Timber Pile Splice".~~the Drawings.~~

~~3.1.33.2.3~~ 3.2.4 Pile Concrete

Concrete shall meet the requirements of Class Pile concrete as specified in Section 4-"Cast-In-Place Concrete".

3.2.4 Reinforcing Steel~~3.2.5 Reinforcing Steel~~

Reinforcing steel ~~incorporated in the pile concrete~~ shall meet the requirements of Section 5-"Reinforcing Steel".

~~3.23.3~~ 3.3 Handling

Piling shall be handled, hauled and stored in a manner that avoids damage to the piling materials. Loading and unloading shall be by crane, loader or other appropriate hoisting equipment.

Care shall be taken in order to prevent damage of galvanized pile surfaces. Fabric slings, wood blocking or other ~~approved~~ methods acceptable to the Consultant, shall be used to support and separate galvanized piling when handling, hauling or storing.~~Piling on which the galvanized coating has been damaged shall be replaced or repaired by the Contractor at his expense as determined by the Consultant. Where repair of damaged galvanizing is required, the repair shall be by metallizing in conformance with ASTM A780, Method A3, to a thickness of 180 µm.~~



Special care shall be taken to avoid breaking through damaging the surface treatment of treated timber piles, ~~and. The use of~~ cant-hooks, dogs, or pike poles shall not be used in the handling of treated timber. Cuts or breaks in the surface of treated timber piles shall be given three brush coats of preservative material ~~of approved quality, acceptable to the Department and the Consultant.~~ Preservative material shall also be ~~applied to~~ applied to all bolt holes.

### ~~3.33.4~~ **3.4** — Driven Piles

#### ~~3.4.1~~ — Equipment and Driving Methods

~~All pile driving equipment, driving methods and procedures shall be reviewed and accepted by the Consultant before pile driving commences. Acceptable driving equipment includes diesel hammers, hydraulic hammers, vibratory hammers, driving frames or other equipment as determined by the Consultant. The use of multi-component drop hammers will not be permitted under any circumstances. The use of gravity hammers will not be permitted except when the required capacity is less than 350 kN, and the Consultant determines the gravity hammer and leads acceptable. Where the use of a gravity hammer is acceptable, the Contractor shall provide the Consultant acceptable proof of its weight including the weight of the follower.~~

~~3.4.1~~ The driving of piles with driving extensions shall be avoided if practicable, and shall be done only under written permission of the Consultant. Pile Driving Equipment

Diesel or hydraulic hammers shall be used for the driving of piling. When hydraulic hammers are proposed the Contractor shall ensure they are configured such that the stroke of the ram is visible and measureable during driving operations to the full satisfaction of the Consultant. Vibratory hammers may be utilized for temporary works or initial insertion of driven piles to achieve alignment and/or support prior to driving setup of diesel or hydraulic hammers.

Pile driving equipment shall be sized such that piles can be driven with reasonable effort to the specified ultimate bearing capacity without damaging the pile, but in no case shall the total energy developed be less than 35 kilojoules (kJ) per blow.

Pile driving equipment shall use fixed leads. The use of hanging leads is not permitted.

A driving cap or follower shall be provided to maintain alignment of the pile and hammer. The driving cap or follower shall be of adequate dimensions to allow driving the pile without trimming or reducing the cross section of the pile.

Driving extensions will only be permitted when reviewed and accepted by the Department and Consultant. When driving extensions are used, one pile from each group of 10 shall be a long pile driven without extensions, and shall be used as a test pile to determine the average capacity of the group. ~~Driving heads, mandrels, or other devices shall be provided in accordance with the manufacturer's recommendations so that the pile may be driven without damage and unnecessary trimming.~~ The use of gravity hammers will not be permitted except when the required pile capacity is less than 350 kilonewtons (kN) and the Consultant determines that the gravity hammer and leads are acceptable. Where the use of a gravity hammer is determined acceptable by the Consultant, the Contractor shall provide the Consultant acceptable proof of its weight including the weight of the follower.

### 3.4.2 Pile Driving Plan

A pile driving plan shall be submitted by the Contractor to the Consultant for review and acceptance a minimum of two weeks prior to the commencement of pile installation. At a minimum, the following information shall be contained in the pile driving plan:

- Specifications, setup and configuration of pile driving equipment including:
  - Hammer Data: Hammer type, manufacturer, model number, serial number, maximum rated energy and range in operating energy, stroke at maximum rated energy and range of operating stroke, ram weight, modifications;
  - Details of onboard equipment capable of energy monitoring;
  - Striker Plate Data: weight, diameter, thickness, composition;
  - Hammer Cushion Data: Manufacturers, area, thickness per plate, number of plates, total thickness, and composition;
  - Helmet Data: Weight, composition; and
  - Pile Cushion Data: Material, area, thickness per sheet, number of sheets, total thickness of cushion;
- Driving methods, procedure and driving sequence;
- Details and drawings of driving frames;
- Pile driving tools and accessories;
- Pile lengths, splicing details, and anticipated splicing locations;
- List of welders and proof of certification;
- Weld procedures;
- ECO plan that includes seepage water management strategy for open ended pipe piles;
- Cold weather protection methods; and
- When specified in the Contract, PDA testing procedures and contact information, and qualifications of independent testing agency.

If during the course of the Work, the required pile set criteria and tip elevations are not achieved, or the Work is not being completed in accordance with Contract requirements, the Contractor shall revise his pile driving plan and resubmit it to the Consultant for review and acceptance before any further pile driving occurs.

The Consultant's review and acceptance of the Contractor's pile driving plan will not relieve the Contractor of his full responsibility for the methods and procedures required to achieve the pile capacity and tip elevations specified in the Contract.

### 3.4.3 Driven Pile Installation

The Contractor shall use steel driving frames for driven pile installations.

For monitoring pile installation, the Contractor shall ~~paint~~apply permanent markings on each pile at 0.25 m intervals with a label at each 1.0 m interval starting from the toe of the pile.

~~The Contractor shall ensure that the piles are in proper position and alignment by using installation driving frames and fixed leads.~~

~~Piles shall not be out of the horizontal position shown on the Drawings by more than 150 mm after driving, except for fully integral abutments the piles shall not be out of horizontal position by more than 50 mm. In addition, for fully integral abutments, the variation in position between the pile casing center and the pile centre shall not be more than 25 mm.~~

~~Piles shall be not driven with a variation of more than 20 mm per metre from the vertical or the batter as shown on the Drawings. Piles in exposed bents shall not be out of position by more than 50 mm at the ground line or 25 mm in the pier cap.~~

#### 3.4.3.1 Pile Driving Set Criteria and Tip Elevation Requirements

The first driven pile for each foundation element will be considered a test pile. When the foundation element contains more than 15 piles the first two driven piles in that foundation element shall be considered test piles. Test piles shall be driven with the same type and size of equipment to be used for the entire foundation element and completed on the same working day. Information from the test pile installations will be used to confirm the pile design and acceptability of the pile driving equipment.

The Consultant will determine an estimated initial pile driving set criteria (blows per 25 mm) for each foundation element using the pile driving hammer information provided in the Contractor's pile driving plan and Wave Equation Analysis of Piles (WEAP).

~~Test If tolerances are not met, the Contractor shall make immediate changes to his piling procedures. Any pile out of the specified tolerance shall be corrected at the Contractor's expense to the full satisfaction of the Consultant.~~

#### 3.4.2 Pile Capacity

~~piles shall be driven to the tip elevations shown on the drawings, or lower as estimated initial pile driving set criteria determined by the Consultant, prior to achieve the required stability and capacity. Pile capacity shall be driving any of the other piles within the foundation element. The test pile elevations determined by the Bearing Formulas of this Specification.~~

~~After pile driving operations have commenced, the Consultant may revise the required pile tip elevations, if necessary, using the pile driving data and Bearing Formulas vary from the tip elevation shown on the Drawings. Test piles shall be 15% longer in length than that shown on the Drawings.~~

~~The Consultant will review the event-estimated initial pile driving set criteria based on the actual pile driving data recorded during test pile driving and provide the Contractor with a pile driving set criteria and tip elevations are not shown on the Drawings, pile capacities for the remaining piles in the associated foundation element. The Contractor shall be drive piles to both the tip elevation and pile driving set criteria determined by the Consultant.~~

~~Payment for test piles will be made at the same unit price bid for the other driven piles, in accordance with Section 3.6 "Pile Capacity Test Methods"-Subsection 3.7.1, Driven Piles.~~

~~The Contractor shall have no claim against the Department for any inconvenience or delay resulting from these requirements.~~

### 3.3.1.1.13.4.3.1.1 Bearing Formulas

~~When not driven to practical refusal, the capacity of piles may be required to be determined by test methods as specified in Section 3.6 "Pile Capacity Test Methods". In the absence of Special Provisions of capacity tests, the Contract, pile capacity shall driving set criteria will be determined by the following Consultant using bearing formulas. For piles driven with diesel or hydraulic hammers the bearing formula will be as follows:~~

#### Diesel and Hydraulic Hammers

$$P = \frac{165 \times E \times F}{S + 5}$$

~~Where~~  $P = \frac{165 \times E \times F}{S + 5}$  ~~, where~~

~~P =~~ P = Pile reaction at service limit state (SLS) extreme load as defined on the Drawings (kilonewtons);

~~E =~~ E = Rated ~~(Potential)~~ energy output of hammer (kilojoules) at corresponding number of blows per minute based on published hammer data sheet;

~~F =~~ F = Efficiency factor = 0.8 or as determined by the Consultant; and

~~S =~~ S = Pile driving set criteria = the average penetration per blow for the last 10 to 20 blows (mm per blow);

~~The Consultant will determine the efficiency factor of the hammer at site by comparing the actual recorded blows per minute to data provided by the manufacturer of the hammer.~~

~~The above formula is applicable only when:~~

~~(1) The head of the pile is not broomed, crushed, or deformed.~~

~~(2) The penetration is reasonably quick and uniform.~~

~~(3)~~

The bearing formula for piles driven with diesel or hydraulic hammers will only be applied when:

- ~~• A driving extension is not used.~~

~~For Gravity Hammers (When accepted for use by the Consultant)~~

$$P = \frac{1650 \times W \times H}{S + 25}$$

~~Where P — Safe bearing value (kilonewtons)~~

~~W — Weight of striking parts of hammer (tonnes)~~

~~H — Height of fall (metres)~~

~~S — The average penetration per blow for the last 5 to 10 blows.~~

~~The above formula is applicable only when:~~

~~(1) The hammer has a free fall.~~

- ~~• (2) — The head of the pile is not broomed, crushed, or deformed.;~~

~~(3) The rate of penetration is reasonably quick and uniform.~~

~~(4) There is no sensible bounce after the blow, or twice the height of the bounce shall be deducted from “H” to determine its value in the formula.~~

~~(5) A driving extension is not used.~~

~~The Contractor shall provide performance specifications for the type of hammer to be used. He will be required to demonstrate that the hammer is performing within the specified limits.~~

### Test Piles

~~Test piles shall be driven where they are specified on the drawings or as required by the Consultant. Test piles shall be longer than the length assumed in design, in order to provide for variations in soil conditions and to explore conditions below the tips of permanent piles. Other dimensions of test piles shall be the same as permanent piles, and shall be driven with the same type and size of equipment.~~

#### 3.4.3 Steel Piles

~~Steel piles shall consist of structural steel shapes or pipes of the section shown on the Drawings or otherwise specified.~~

~~When pipe piles are to be driven closed-ended, one section of pipe for each pile shall be supplied with a welded pipe pile end plate in accordance with Standard Drawing S-1479 “Standard Closed Pipe Pile End Plate”.~~

- ~~When pipe piles are to be driven open-ended and the interiors cleaned out, a power screw rotary auger, acceptable to the Consultant shall be used to remove the required material. All loose material and all material adhering to the walls of the piles shall be removed; and~~
- A driving extension is not used.

#### 3.4.3.2 After installation Steel Piling

Steel pile heads shall be cut square and neat.

When specified in the Contract documents, pile tip reinforcement shall be installed in accordance with Standard Drawing S-1850, Standard Steel Pile Details.

When pipe piles are to be driven closed ended or, pipe pile tips shall have welded end plates installed in accordance with Standard Drawing S-1850, Standard Steel Pile Details.

At the completion of driving open-ended pipe piles shall be filled with pile the thickness of accumulated material in the pipe pile shall be measured and recorded. Upon completion of the measurements and review and acceptance of the Consultant, the interiors shall be cleaned out to the required elevation. All material, either loose or adhering to the walls of the pipe piles shall be removed to the satisfaction of the Consultant prior to installing reinforcing steel or placing concrete. Driving of any type of piles within 3 m of a pipe pile or integral pile that contains concrete shall not be undertaken until the concrete has been placed and cured for a minimum of 3 days.

~~The total energy developed by the hammer shall be sufficient to achieve the required capacity or tip elevation, but in no case shall the total energy developed be less than 35 kJ per blow.~~

The head shall be cut squarely and a driving cap or follower shall be provided to hold the axis of the pile in line with the axis of the hammer. The follower shall be of adequate dimensions to allow driving the pile without trimming or reducing the cross-section of the pile. Pipe pile concrete shall not be placed until the pipe pile has been reviewed and accepted by the Consultant. Any reinforcing required projecting from the pipe pile shall be installed and secured prior to concrete placement. If water is observed to ingress into the pipe pile the concrete shall be placed in accordance with Subsection 4.22, Placing Concrete under Water, and Subsection 3.5.3.3, Pile Concrete, after the ingress of water has reached an equilibrium elevation as determined by the Consultant.

When damage or buckling is evident at the driving end of the pile in order to obtain the desired capacity or penetration of the pile or buckling at any location occurs, the Contractor shall at immediately stop pile driving and revise and resubmit his own expense reinforce pile driving plan to the Consultant. The Contractor shall not continue pile driving until the revised pile driving plan has been reviewed and accepted by the Consultant. All costs and schedule impacts associated with the required modifications to the pile driving plan will be considered incidental to the Work and no additional or separate payment will be made. Modification may include, but are not limited to, reinforcing the driving end of the piling, or provide other suitable or utilizing different pile driving equipment or procedures, to prevent such damage. Damaged piles shall be addressed in accordance with Subsection 3.5.5, Defective Piles.

Steel piles shall be cut off level at the required elevation. ~~If capping is required, the connection shall be made according to details shown on the drawings.~~

The Contractor shall ~~supply and secure temporary caps on~~cover all open pipe piles ~~or~~/drilled holes.

#### 3.4.3.1—Steel Pile Splices

~~When splicing, until concrete or backfill is placed. Coverings shall be designed, supplied, installed, secured and maintained by the Contractor shall employ whatever means necessary, in a manner acceptable to match out-of-round piling. Exposed pile splices shall be avoided. Refer to Standard Drawing S-1415 “Standard H-Pile Splice” and Standard Drawing S-1414 “Standard Pipe Pile Splice”. All welding in the field shall be in accordance with section 13.4.1~~Consultant.

#### 3.4.3.3 Steel Piling Splices

Steel pile splices shall be in accordance with Standard Drawing S-1850, Standard Steel Pile Details. All field-welding shall be in accordance with Subsection 13.4.1, Field Welding of Structural Members.

The Contractor shall locate steel piling splices such that the final location of the splice is 1 m below ground level or at an elevation acceptable to the Consultant.

Where the upper portions of piling are specified to be galvanized, excess piling shall be removed from the ungalvanized portion of the piling to ensure that the galvanized portion extends to the elevation shown on the Drawings. Splicing within the galvanized portion of the piling shall be avoided; ~~however,~~ if splicing within the galvanized portion becomes necessary due, the galvanizing shall be removed to unforeseen circumstances, the extent required to complete the splice in a manner acceptable to the Consultant. The spliced areas and any other damage galvanized area areas shall be metallized in accordance with ASTM A780, Method A3 to a thickness of 180 µm, ~~by the Contractor at his cost and tested for adhesion. All costs associated with metallizing and testing will be considered incidental to the Work, and no separate or additional payment will be made.~~

3.4.3.2 For steel pipe piling, methods acceptable to the Consultant shall be used to match out-of-round piling. Weld procedures shall be suitable for any steel pipe pile where out-of-round conditions are present.

#### 3.4.3.4 Testing of Steel Piling Splices

The Contractor shall have all steel piling splice welds visually inspected by the Contractor and an independent welding inspector certified to Level 3 of CSA W178.2.

For each bridge component, the Contractor shall also perform ultrasonic testing for a minimum of 20% of all full penetration welded splices in compression.

The Contractor shall perform ultrasonic testing for ~~a minimum~~100% of ~~20% of all~~ full penetration compression splice welds for all piles for each bridge component. ~~Ultrasonic testing shall also be completed for welds~~welded splices in which ~~tension~~.

~~If visual inspection indicates~~of the ~~presences of a weld reveals the presence of~~ potential defect. ~~Additional testing may be required for the full penetration compression splice welds to ensure~~defects, the integrity of the structure. ~~Consultant will require~~ the Contractor shall test 100% of full penetration tension splice welds as shown on ~~to~~ complete additional ultrasonic testing to that already specified to confirm the Drawings.

~~acceptability of the weld. The Consultant will determine the scope of additional ultrasonic testing shall be done~~to be completed and the acceptability of the weld. If welds are determined unacceptable by the Consultant, the Contractor shall repair the weld at his expense to the full satisfaction of the Consultant and the Department.

All ultrasonic testing shall be completed by ~~an~~ independent testing company certified to CAN/CSA W178.1. Ultrasonic testing technicians shall be certified to Level ~~#2~~ of Canadian General Standard Board (CGSB). A copy of test results shall be provided to the Consultant for his review within three days of the testing. ~~The Consultant may require additional testing and inspection if determined necessary.~~

All costs associated with ~~weld~~ testing shall be included in the price bid for the Work and no separate or additional payment will be made.

#### ~~3.4.4~~ Timber Piles

~~Gravity hammers when accepted for driving timber piles shall weigh not less than 1.5 t, and in no case shall the weight of the hammer be less than the combined weight of driving head and pile. The fall shall be so regulated as to avoid injury to the piles and in no case shall exceed 3 m. When a diesel hammer is used total energy developed by the hammer shall be not less than 15 kJ per blow.~~

~~The pile head shall be cut squarely and a driving cap or follower shall be provided to hold the axis of the pile in line with the axis of the hammer. The follower shall be of adequate dimensions to allow driving the pile without in any way trimming or reducing the cross-section of the pile.~~

#### 3.4.3.5 Reinforcing Steel

Reinforcing steel shall be fabricated, shipped, handled, stored, placed, fastened and spliced in accordance with these specifications, Section 5, Reinforcing Steel, and as shown on the Drawings.

Reinforcing steel shall be positioned and braced to achieve placement tolerances specified in Section 5, Reinforcing Steel. Shoes or spacers shall be firmly attached to the reinforcement to ensure the reinforcement is kept in position during concrete placement and cover requirements are met.



Projecting reinforcing steel shall be located such that it is within a tolerance of  $\pm 10$  mm or as determined by the Consultant.

#### 3.4.3.6 Pile Concrete

All Work shall be completed in accordance with Section 4, Cast-In-Place Concrete, and Subsection 3.5.3.3, Pile Concrete.

#### 3.4.3.7 Timber Piles

Full length timber piles shall be used.

The Contractor shall provide and install collars, bands, or other devices to prevent timber piles from splitting or brooming.

When required, timber piles shall be installed with steel shoes that are designed and supplied by the Contractor.

Gravity hammers, when accepted by the Consultant for driving timber piles, shall weigh not less than 1.5 tonnes, and in no case shall the weight of the hammer be less than the combined weight of driving head and pile. The height of the fall shall be such that damage to the piles does not occur.

When a diesel hammer is used for driving of timber piles, the total energy of the hammer shall be greater than 15 kilojoules.

When the area of the head of any timber pile is greater than that of the face of the hammer, a ~~suitable~~ follower shall be provided to distribute the blow of the hammer throughout the cross -section of the pile ~~and thus avoid splitting or shattering the pile.~~

~~Timber piles shall be pointed where soil conditions require it. When necessary, the piles shall be shod with metal shoes, supplied by the Contractor, of a design satisfactory to the Consultant, the points of the piles being carefully shaped cut to secure an even and uniform bearing on match the shoes.~~

~~Full length piles shall be used where practicable. In exceptional circumstances splicing plane of piles may be permitted. The method of splicing shall be the supporting timber caps as shown on the Drawings or as reviewed and accepted by the Consultant. Refer to Standard Drawing S-1413 "Standard Timber Pile Splice" included with these Specifications.~~

~~The tops of all piling shall be trimmed to a true plane at the elevation shown on the drawings or fixed by the Consultant. Piles which support timber caps or grillage shall be sawed to conform to the plane of the bottom of the super-imposed structure. In general, The length of pile above the elevation of cut -off shall be sufficient to permit the complete removal of all material injured by driving, but piles driven to very nearly the cut-off elevation shall be carefully trimmed and freed of all "All broomed", splintered or otherwise injured damaged material shall be completely removed.~~

3.4.3.8 Driven Pile Installation Tolerances

Piles shall not be driven with a variation of more than 150 mm from the horizontal position shown on the Drawings, except for fully integral abutments the piles shall not be driven with a variation of more than 50 mm from the horizontal position. In addition, for fully integral abutments, the variation in position between the center of the pile casing and center of the pile shall not be more than 25 mm from the horizontal position shown on the Drawings.

Piles shall be driven with a variation not exceeding more than 20 mm per metre from the vertical alignment shown on the Drawings. Piles in exposed bents shall not be out of position by more than 50 mm at the ground line and 25 mm in the pier cap.

At the completion of driving of each pile within a foundation element, a control elevation shall be established on the pile by the Contractor to determine if heave has occurred after all piles for the foundation element have been driven. Piles that heave shall be re-driven to the depth and capacity required by the Contract or as determined by the Consultant.

If tolerances are not met, the Contractor shall make immediate changes to his piling procedures. Any pile out of the specified tolerance shall be corrected at the Contractor's expense to the full satisfaction of the Consultant.

3.3.23.4.4 3.4.5—Defective Piles

The ~~method~~equipment and methods used to drive piles shall not result in deformation of the steel, splitting, splintering or brooming of the wood, or crushing and spalling of the concrete. Manipulation of piles to force them into proper position, considered by the Consultant to be harmful, will not be permitted. Piles damaged by driving, or driven out of proper location, or driven below the cut-off elevation, shall be corrected by the Contractor at his expense by using one of the following methods acceptable to the Consultant: or any other damage.

(a) — The Manipulation of piles to adjust position, considered by the Consultant to be harmful, will not be permitted.

Piles damaged by driving, or driven out of specified tolerance, orientation, or driven below the cut off elevation, shall be repaired by the Contractor at his expense. The Contractor shall submit a repair procedure to the Consultant for review and acceptance before any further piling is installed. The Contractor's repair procedures, as a minimum, shall include one of the following:

- The defective piling shall be withdrawn and replaced ~~by~~with new, and if necessary, longer piles, ~~or~~;
- (b) — Replacement ~~piles~~piling shall be driven adjacent to ~~the~~ defective ~~or low~~piles;

The defective piles, ~~or~~

- (c) — The piles, ~~except timber piles,~~ shall be spliced or built up; ~~or~~
- A sufficient portion of the pile cap extended and reinforced.

Piling on which the galvanized coating has been damaged, as determined by the Consultant, shall be replaced or repaired by the Contractor at his expense. Where repair of damaged galvanizing is required, it shall be completed in accordance with Subsection 6.2.7.3, Galvanizing.

(d) ~~A sufficient portion~~ Splicing of the footing extended to properly embed the defective timber piles.

~~All piles, pushed up by the driving of adjacent piles or by any other cause, shall be driven down again.~~

~~When the required penetration and capacity are not achieved, the Contractor shall provide a hammer of greater energy or, when accepted by the Consultant, pre-drill the piles. Providing a hammer with greater energy and/or pre-drilling the piles to achieve acceptable penetration and capacity will be considered incidental to the Work and no separate or additional payment will be made not be permitted.~~

### 3.4.6—Measurement and Payment

#### Supply of Piling

~~Payment for Supply of Piling will be made on the basis of the unit price per metre bid for each type of piling supplied, which price shall include full compensation for the cost of furnishing and delivering the material to site. The unit prices shall include full compensation for the cost of all labour, tools, equipment and other necessary or incidental costs of handling, loading and hauling the piling.~~

~~The number of metres of piling to be paid for shall be the total number of metres acceptably driven and remaining in the completed structure. Where portions of steel piling are specified to be galvanized, only the lengths requiring galvanizing will be included in supply of galvanized steel piling. All steel piling below the level of the galvanized piling length shown on the drawings will be included in supply of plain steel piling.~~

#### Re-stocking Steel Piling

~~When quantities of plain Steel Pipe or H Piles are reduced by 15% or more due to conditions beyond the Contractor's control, the Department will reimburse re-stocking costs for 6.0 metre lengths or longer, incurred by the supplier to the Contractor.~~

~~The Contractor shall present vouchers giving details as to dates, quantities, rates, third party invoices, and such other supporting documentation to the Consultant. Payment will be made on the cost of re-stocking only based on third party invoices excluding labour burden, overhead and profit.~~

#### Pile Set-up

Payment for **Pile Set-up** will be made on the basis of the unit price per pile bid, which price shall include the expense and time to set the equipment over the pile, ready to commence driving. Payment will be made only for piles acceptably driven as determined by the Consultant.

#### Pile Driving

Payment for **Pile Driving** will be made on the basis of the unit price per metre bid, which price shall include full compensation for the cost of furnishing all labour, tools, equipment and incidentals associated with handling, driving, splicing, cutting, and tip reinforcing necessary to obtain the required penetration or capacity.

The number of metres paid shall be the total number of metres of piling acceptably driven and remaining in the completed structure.

#### ~~3.3.2.13.1.1~~ **Pile Tip Reinforcement**

When the Contract contains a bid item for **Pile Tip Reinforcement**, payment will be made on the basis of the unit price bid, which price shall include full compensation for all labour, materials, equipment, tools and all incidentals necessary to complete the work.

#### ~~3.3.2.23.1.1.1~~ **Pile Splicing**

Where piles penetrate further than 20% of the estimated tip elevation, splicing will be paid for at the assigned unit price for pile splicing and will include all labour, materials, equipment, tools and incidentals necessary to complete the work. Only one splice for each additional length of pile, up to twelve metres, will be paid for.

The unit price for pile splicing shall be:

H-Piles: ——— \$1000

Pipe Piles: ——— \$1200

#### Pile Concrete

**Pile Concrete** shall be measured and paid for in accordance with Section 4 “Cast-In-Place Concrete”.

#### ~~3.3.33.1.1~~ **Reinforcing Steel**

**Reinforcing Steel** incorporated in the piling will be paid for in accordance with Section 5 “Reinforcing Steel”.

#### Test Piles

Test piles retained in the structure will be paid for at the bid price of other piling used.

If test piles are not incorporated into the final structure, they will be paid for as Extra Work.

**3.43.5 3.5 — Drilled Cast-In-Place Concrete Piles****3.5.1 — General**

~~In addition to drilled cast-in-place concrete piles this section shall include drilled cast-in-place concrete/steel pipe composite piles. The work shall include drilling and belling the holes, as required, supplying and placing the steel pipe and reinforcing steel, and supplying, placing, protecting and curing the concrete.~~

**3.5.2 — Equipment and Drilling Methods**

~~Due to the nature of the work, the Department requires that the drilling subcontractor have adequate equipment and a proven record of competence in this work.~~

~~3.5.1 All pile drilling equipment, drilling methods and procedures shall be reviewed and accepted by the Consultant before drilling is started. Unless otherwise specified only powered~~Pile Drilling Equipment

Only screw rotary type augers shall be used.

Hydraulic oscillating equipment will be acceptable.

~~The Contractor shall not proceed with permitted for~~ the installation of further piling, if for any reason the temporary or permanent casings.

Continuous flight auger equipment is not permitted.

**3.5.2 — Pile Drilling Plan**

The Contractor shall have demonstrated experience related to the successful completion of projects with similar scopes of Work and ensure that the equipment used is in adequate in quantity, quality of the adjacent piling is compromised due to the effects of vibration or other reasons and in good operating condition.

~~3.5.3 A pile drilling plan shall be submitted by the Contractor to the Consultant a minimum of 2 weeks prior to the commencement of pile installation for review and acceptance. At a minimum, the following information shall be contained in the pile drilling plan:~~

- Summary of Contractor's experience related to the project scope of work;
  - Project personnel resumes; and
  - Client contact information;
- Specifications, setup and configuration of piling equipment;
- Drilling methods, procedure and drilling sequence (including methodology to address the presence of boulders, hard rock stringers, or occurrences of pile wall sloughing and/or ingress of water);
- List of drilling tools and attachments for belling and cleaning;
- List of proposed casing lengths and diameters to be available on site;
- Method of gas detection;
- Methods to install and remove temporary casing;

- Availability of borehole camera;
- Concrete mix design review letter in accordance with Section 4, Cast-In-Place Pile CapacityConcrete;
- Where cast-Reinforcing steel mill test reports in-place piles are designed using semi-empirical accordance with Section 5, Reinforcing Steel;
- Cold weather protection methods;
- ECO plan that includes seepage water management strategy; and supported by a comprehensive geotechnical investigation with field testing and construction
- Sample piling monitoring records.

If during the ultimate bearing capacity may be adjusted for Limit State Design by a geotechnical resistance factor of 0.4. If working state design methods are used the allowable loads, the required pile capacities and tip elevations are not achieved, or the Work is not being completed in accordance with the Contract requirements, the Contractor shall be as determined by revise his pile drilling plan and resubmit it to the Consultant for review and acceptance before any further piling Work occurs.

#### 3.5.4 Drilling Pile Holes

The Consultant's review and acceptance of the Contractor's pile drilling plan will not relieve the Contractor of his full responsibility for the methods and procedures required to achieve the pile capacity and tip elevations specified in the Contract.

#### 3.5.3 Drilled Pile Installation

Drilled pile holes shall be stabilized and sealed by means of temporary casings or other methods to prevent the possible collapse of the pile holes or ingress of water. The Contractor shall make every attempt necessary to obtain dry pile holes prior to placing pile concrete. To assist in the Contractor's attempts to achieve a dry hole he shall, at a minimum, the Contractor shall have available for use on site casings of appropriate size and lengths, bailing buckets, final cleanout buckets and water pumps, ready for use in the Work. A drilled pile hole will be considered dry when the seepage rate into the drilled pile hole is less than 300 mm per hour and the water can be controlled by pumps or other means to reduce the depth of accumulated water to 75 mm or less at the time of concrete placement.

Seepage water removed from pile holes shall be managed in compliance with all environmental regulations by discharging it into settlement tanks or ponds, hauling and disposing offsite, or other methods acceptable to the Consultant. A seepage water management strategy shall be included in the Contractor's ECO plan and submitted with the pile drilling plan.

Temporary ~~casing~~casings, if used in drilling operations, shall be removed from the hole ~~as pile concrete is being placed by vibration or hydraulic oscillation and of sufficient strength to withstand repeated use and any forces required to install or retrieve it.~~ The internal diameter of casings shall be the same size as the specified pile diameter and of sufficient length to permit drilling operations to proceed unimpeded. The bottom of the casing shall be maintained sufficiently below the top of the concrete during withdrawal and placing operations ~~unless otherwise permitted by the Consultant. Separation of the concrete during withdrawal operations shall be avoided by hammering or otherwise vibrating the casing.~~

Pile hole tip elevations shown on the Drawings shall be considered approximate only, and the Consultant may determine further drilling is necessary to achieve satisfactory capacity of the piles. For dry holes, the Contractor shall provide borehole video inspection equipment when determined necessary by the Consultant. The borehole video inspection equipment shall be installed with lighting and resolution acceptable to the Consultant.

Where bellling of the piles is specified, bellling shall proceed only after the pile hole has been drilled to an elevation acceptable to the Consultant.

The walls and bottoms of the pile holes shall be cleaned to remove all loose and extraneous material. The Contractor shall determine if any noxious or explosive gas is present in the pile holes and shall provide whatever means and equipment necessary to ensure a safe work site. ~~Pile reinforcement and pile concrete shall not be placed without the acceptance of the pile holes by the Consultant.~~

~~3.5.5—Pile reinforcement and pile concrete shall not be placed without the acceptance of the pile holes by the Consultant. The Consultant shall be permitted full and safe access to the drill hole to allow inspection of drilling operations, evaluation of soil or rock cuttings, presence of water ingress or wall sloughing, tip elevations, or other reasons determined necessary by the Consultant. The time elapsed between the completion of the pile hole, reinforcement installation and concrete placement shall be acceptable to the Consultant.~~

### Open Drilled Holes

The Contractor shall not proceed with the installation of adjacent piling, if for any reason the quality of the adjacent piling becomes compromised, as determined by the Consultant.

#### 3.5.3.1 Open Drilled Holes be responsible for covering

~~The Contractor shall cover all open drilled holes on the site until the time they are filled with concrete or otherwise properly backfilled. The covers shall be of adequate strength and securely fitted so that machinery and workmen are protected against cave-in and surface water concrete or backfill is prevented from running into the pile hole placed. Coverings shall be highly visible, designed, supplied, installed, secured and maintained by the Contractor, in a manner acceptable to the Consultant.~~

#### 3.5.6 Reinforcement

### 3.5.3.2 Reinforcing Steel reinforcement

Reinforcing steel shall be fabricated, shipped, handled, stored, placed, fastened and spliced in the sizes and to the dimensions accordance with these specifications, Section 5, Reinforcing Steel and as shown on the Drawings and.

Reinforcing steel shall be placed, centered positioned and braced to achieve placement tolerances specified in the pile hole to the acceptance of the Consultant.

Particular care shall be taken in locating projecting reinforcing steel, to a tolerance not exceeding 10 mm in any direction, and casting will not be permitted until the Consultant is satisfied that adequate provisions have been made.

Adequate “shoes” Section 5, Reinforcing Steel. Shoes or spacers shall be firmly anchored attached to the reinforcement to ensure the reinforcement is kept centered in the position during concrete placement and cover requirements are met.

3.5.7—Projecting reinforcing steel shall be located such that it is within a tolerance of  $\pm 10$  mm or as determined by the Consultant.

### 3.5.3.3 Pile Concrete Placement

All Work shall be completed in accordance with Section 4, Cast-In-Place Concrete and this specification.

Suitable forms shall be used to maintain the specified dimensions of concrete piles above ground level. When the reinforcement has been acceptably placed, concrete shall be immediately deposited in the pile hole. ~~The concrete shall be “Pile Concrete” and the provisions of Section 4 “Cast-In-Place Concrete” shall apply.~~

~~Suitable forms shall be used to maintain the specified dimensions of concrete piles above ground level.~~ The Contractor shall remove all laitance, unsound concrete, or other deleterious material from concrete surfaces as determined by the Consultant by chipping or other means acceptable to the Consultant.

#### 3.5.3.3.1 Pile Concrete Placed in the Dry

Pile concrete shall be placed by means of a hopper equipped with a center pipe drop tube. The pipe drop tube shall be a minimum of 200 mm in diameter and 2 m long. Concrete may be placed free fall, providing the fall is vertically down the center of the casing or drilled hole and there are no transverse ties or spacers. Pile concrete shall have a slump range of  $130 \pm 30$  mm at time of discharge. Concrete in the upper 3 m of the piles shall be consolidated by the use of an acceptable concrete vibrator.



### 3.5.3.3.2 Pile Concrete Placed under Water ~~shall be completed~~

If in the opinion of the Consultant and the Department all attempts to achieve a dry pile hole have been taken and proven unsuccessful, placement of pile concrete under water will be required.

When the Department and the Consultant accept pile concrete placed underwater, the pile concrete shall be placed in accordance with Section ~~Subsection~~ 4 and requires validation by .22, Placing Concrete under Water and this specification.

The integrity of the pile shall be tested and verified using Crosshole Sonic Logging (CSL-) as described in Subsection 3.5.3.3.3, Crosshole Sonic Logging.

### 3.5.3.3.3 3.5.8—Crosshole Sonic Logging

All piles with concrete placed under water shall have CSL completed to confirm pile integrity. The Contractor shall complete CSL testing in accordance with ASTM D6760, Standard Test Method for Integrity Testing of Concrete Deep Foundations by Ultrasonic Crosshole Testing and this specification.

The Contractor shall hire an independent CSL testing agency that has a minimum of three years' experience in CSL testing. A Professional Engineer employed by the independent CSL testing agency and registered in the Province of Alberta shall supervise the CSL testing and prepare a CSL testing report.

CSL testing shall be completed within 3 to 7 days after concrete placement as determined by the independent CSL testing agency.

The Contractor shall supply and install one 50 mm inside diameter tube for each 0.3 m of pile diameter with a minimum of 4 tubes per pile. Tubes supplied shall be round PVC or steel material of a grade acceptable to the Consultant and have a regular internal diameter that is free from defects, obstructions and joints. Tubes shall be watertight, free of corrosion, have clean internal faces and roughened external faces to ensure a good bond between the concrete and the tubes. Tubes may be extended with watertight mechanical couplings and all coupling locations shall be recorded. Tubes shall be installed by the Contractor in a manner that the CSL probes pass through the entire length of the tube without binding.

The Contractor shall fit the tubes with a watertight shoe on the bottom and a removable cap on the top. Tubes shall be secured to the interior of the reinforcement stirrups a minimum of every 1.0 m along the length of the pile. Tubes shall be installed parallel to each other and equidistant around the circumference of the pile. Tubes shall be installed a minimum of 40 mm away from vertical bars. Tubes shall extend to within 150 mm of the drilled shaft bottoms, and shall extend a minimum of 600 mm above the drilled shaft tops or where they are accessible. Tubes shall be capped to prevent debris from entering the access tubes.

The Contractor shall ensure that CSL tubes are not damaged during the installation of the reinforcement. Tubes shall be filled with water to prevent damage during concrete placement. The water shall be a minimum of 4°C immediately prior to concrete placement. If testing equipment does not pass through the entire length of the CSL tube, a 50 mm diameter core hole shall be drilled. Special care must be taken to avoid tube debonding between the concrete and the tubes. If tube debonding occurs, the Contractor shall core drill a 50 mm diameter hole to the depth of debonding for each debonded tube.

The Contractor shall make CSL measurements at depth intervals of 50 mm from the bottom of the tubes to the top of each pile. Upon completion of testing and acceptance of the pile concrete, the tubes shall be filled with an approved grout mix having the same design strength and durability as the pile concrete.

The Contractor shall submit the CSL testing report to the Consultant and the Department within 5 days of CSL testing completion. The CSL testing report shall include test summaries, results, analyses, and an opinion of the pile concrete's integrity and suitability for the intended use. The Contractor shall not grout the CSL tubes or perform any further work on the CSL tested drilled piles until it has been demonstrated to the Consultant and the Department's satisfaction that the drilled pile is acceptable. Test summaries shall be in accordance with the criteria listed in Table 3-1, CSL Condition Ratings.

**Table 3-1: CSL Condition Ratings**

<b><u>Condition Rating</u></b>	<b><u>Velocity Reduction</u></b>	<b><u>CSL Results</u></b>
<u>Good (G)</u>	<u>≤ 10%</u>	<u>Good quality concrete.</u>
<u>Questionable (Q)</u>	<u>&gt;10% &amp; &lt;20%</u>	<u>Minor contamination or intrusion. Questionable quality concrete.</u>
<u>Poor/Flaw (P/F)</u>	<u>≥ 20% &amp; &lt;30%</u>	<u>Flaws exists, possible water/slurry contamination, soil intrusion and/or poor quality concrete.</u>
<u>Poor/Defect (P/D)</u>	<u>≥ 30%</u>	<u>Defects exists, possible water/slurry contamination, soil intrusion and/or poor quality concrete.</u>
<u>No Signal (NS)</u>	<u>No Signal Received</u>	<u>Soil intrusion or other severe defect absorbed the signal.</u>

Velocity reduction criteria outlined in Table 3-1, CSL Condition Ratings, shall be from the highest measured signal velocity in the comparable zone.

Piles with condition ratings other than "G" will be considered unacceptable and will result in rejection of the pile. If the Contractor elects to carry out further investigation to provide supplemental information of the pile's integrity, the flawed and/or defective zones shall be evaluated using cross-hole tomography, concrete coring, and any other testing required by the Consultant. The Consultant in consultation with the independent CSL testing agency's Engineer will determine the depth, location, diameter and number of cores to be extracted. If the Consultant determines the use of a borehole camera for inspection is also required, large diameter cores may be required. A minimum of two cores will be required to intercept the suspected flaw or defect zones.

When the Consultant and the Department determine a drilled pile is unacceptable, the Contractor shall submit a repair procedure with supporting design calculations and drawings signed and sealed by a Professional Engineer registered in the Province of Alberta to the Consultant and the Department for review and acceptance a minimum of 2 weeks prior to commencement of the repair work. The pile will not be considered acceptable until all repair work has been completed, reviewed and accepted by the Consultant and the Department.

#### 3.4.1.43.5.3.4 Cold Weather Conditions

When the ground temperature against which pile concrete is placed ~~is~~ below -5 °C, the pile hole shall be hoarded and heated until the ground temperature is warmer than 10 °C or oversized by 100 mm. Immediately after placing and finishing the pile concrete, the top exposed surface shall be protected with insulated tarps or other means to adequately cure the concrete for a period of seven days. If the top of the pile extends above the ground surface it shall be protected in accordance with Section 4 ~~"Concreting in Cold Weather"~~, Cast-In-Place Concrete.

#### 3.5.9 Pile Tolerance

##### 3.5.3.5 Drilled Pile Installation Tolerances

Piles shall be installed with a variation not be out of exceeding more than 50 mm from the horizontal position shown on the Drawings ~~by more than 50 mm.~~

Piles shall be installed with a variation not be out of the exceeding more than 20 mm per metre from the vertical ~~or batter~~ alignment shown on the Drawings.

Projecting reinforcing steel shall be installed with a variation not exceeding more than 10 mm in any direction from the position shown on the Drawings.

If tolerances are not met, the Contractor shall make immediate changes to his piling procedures. Any pile out of the specified tolerance shall be corrected at the Contractor's expense to the full satisfaction of the Consultant.

#### 3.5.4 Drilled Pile Capacity

Piles shall be drilled to the capacity and tip elevation shown on the Drawings or as determined by the Consultant. Pile capacities will be determined by more than 20 mm per metre. the Consultant using geotechnical inspection and evaluation. When specified in the Contract, the Contractor shall complete pile capacity testing in accordance with Subsection 3.6, Pile Capacity Testing and Reporting, and the results reviewed and accepted by the Consultant.

#### 3.5.5 Defective Piles

Manipulation of reinforcement to adjust position, considered by the Consultant to have the potential to damage the pile integrity, will not be permitted.

A decrease in concrete elevation at the top of a completed pile more than 2% of the pile diameter between the time of initial pour and set will be considered a damaged pile.

Piles damaged during drilling, reinforcing steel installation, or concrete placement shall be repaired by the Contractor at his expense. The Contractor shall submit a repair procedure to the Consultant for review and acceptance before any further piling is installed. The Contractor's repair procedures, as a minimum, shall include one of the following:

- The defective piling shall be re-drilled and replaced by new, and if necessary, longer piles;
- Concrete removal and replacement;
- The defective piles shall be built up; or
- A sufficient portion of the pile cap extended and reinforced.

### 3.6 Pile Capacity Testing and Reporting

#### 3.6.1 Static Load Testing

When specified in the Contract, Static Load testing shall be completed by an independent testing agency specializing in this type of Work. The independent testing agency shall be engaged by the Contractor and supply and install all testing equipment and analyze the test results in accordance with this specification. The Contractor shall be responsible to coordinate and manage all associated static load testing activities.

Static load testing and reporting shall be completed in accordance with ASTM D1143 for piles subjected to axial loads and ASTM D3689 for piles subjected to axial tensile loads and as outlined in the Contract documents. As a minimum, the report shall include the following:

- Site plan showing locations of test pile and nearest test holes;
- Test hole logs and summary of subsurface conditions;
- Type and dimensions of test and anchor piles;
- Test pile material including basic specifications;
- Pile installation details;
- Final pile top and tip elevations;

- Ground surface elevation;
- Date and type of load test;
- Temperature and weather conditions during the test;
- Description of instrumentation used to monitor pile performance during testing including their locations;
- Description of test setup and testing procedures;
- Tabulation of time, load, and displacement readings;
- Interpretation and analyses of test results including failure load and the criterion used to estimate it, shaft friction, and end bearing resistance (as applicable);
- Pile load-movement curve; and
- Pile time-load and time-movement curves.

The static load test report shall be submitted to the Consultant for review and acceptance within 7 days of completion of testing.

Osterberg or Statnamic tests may be proposed by the Contractor in substitution for static load testing. Osterberg tests shall conform to ASTM D1143 Standard Test Method for Piles under Static Axial Load using the Quick Load Test Method for Individual Piles. Statnamic tests shall conform to ASTM D7383 Standard Test Methods for Axial Compressive Force Pulse (Rapid) Testing of Deep Foundations. The Contractor shall submit details of all proposed testing measures in his piling plan and the Consultant, at his sole discretion, will accept or reject the Contractor's substitution proposal.

The Contractor shall have no claim against the Department for any inconvenience or delay resulting from these requirements.

### 3.6.2 High Strain Dynamic Load Testing - Pile Driving Analysis (PDA Testing)

When specified in the Contract, PDA testing shall be completed by an independent testing agency that has specialized in this type of Work for a minimum of 5 years. The independent testing agency shall be engaged by the Contractor and supply and install all testing equipment and analyze the test results in accordance with this specification. The Contractor shall be responsible to coordinate and manage all associated PDA testing activities.

The Contractor shall provide the Consultant a minimum of two weeks advance notice of any scheduled PDA testing.

#### 3.6.2.1 Testing Requirements

PDA testing shall be completed in accordance with ASTM D4945.

The impact device used for PDA testing shall be acceptable to the Consultant and capable of mobilizing the ultimate pile capacity in a single blow without additional data interpretation.

The greater of 2 piles or 15% of the total production piles from each foundation element shall be PDA tested. For pile walls where more than 40 piles are to be installed the greater of 6 piles or 10% of the total production piles in each wall shall be PDA tested. The remaining pilings will have their capacities evaluated based on the field adjusted WEAP analysis produced from the PDA testing process.

Testing shall occur during complete installation of driven piles and upon re-strike when re-striking is specified in the Special Provisions of the Contract. The required pile set-up time until re-strike occurs and all associated details will also be outlined in the Special Provisions of the Contract.

The Contractor shall include any costs associated with re-striking in the unit price bid and shall have no claim against the Department resulting from any delays caused by these requirements. If re-striking test results do not meet the specified requirements, the Contractor shall continue pile driving until results acceptable to the Consultant is achieved.

Additional PDA testing may be required when driven piles exhibit lower capacity and/or shorter penetrations than specified, or cast-in-place piles encounter ground water, or piling equipment or procedures change. The Consultant will determine the scope and number of additional PDA tests to be completed and this additional testing will be paid for at the unit price bid.

If the Contractor demobilizes from the foundation element before the Consultant's acceptance is received, all remobilization and associated costs will be at the Contractor's expense.

The Contractor shall have no claim against the Department for any inconvenience or delay resulting from these requirements.

#### 3.6.2.2 Reporting Requirements

The independent testing agency shall provide a daily field log to the Consultant within 24 hours of testing, summarizing preliminary test results including driving stresses, transferred energy and estimated pile capacity. Upon review of the daily field log(s), tip elevations may be revised by the Consultant.

The independent testing agency shall also provide a summary letter report that includes complete PDA test results and analysis for each foundation element tested. The summary letter report(s) shall be prepared in accordance with the requirements of ASTM D4945 and these specifications. As a minimum, the summary letter report shall include the following:

- Pile and driving system information;
- Pile installation data;
- PDA testing equipment and procedure;
- Energy imparted;
- Maximum driving stresses;
- Hammer blow rate;
- Signal matching input parameters including quake and damping factors; and
- Shaft friction, end bearing and total pile capacity.

The summary letter report(s) shall be signed and sealed by a Professional Engineer employed by the independent testing agency. The summary letter report(s) shall be submitted to the Consultant within 3 days of PDA testing completion for each foundation element. The Consultant will provide the Contractor written acceptance, rejection, or a list of items requiring review and resubmission of the summary letter report within 3 business days of its receipt.

### **3.7 Measurement and Payment**

#### **3.7.1 Driven Piles**

##### **3.7.1.1 Supply of Piling**

Measurement for payment of supply of piling will be by the metre of piling acceptably supplied, measured to the nearest 0.1 m.

The quantity to be paid will be the length of piling acceptably driven and remaining in the completed structure. Where portions of steel piling are specified to be galvanized, only the specified lengths requiring galvanizing will be included in the quantity to be paid.

Payment will be made at the unit prices bid for “Supply of Piling”, for each type and size of piling specified, and will be full compensation for the supply of the piling; loading; delivery; and unloading of the material to the project site; and all labour, equipment, tools and incidentals necessary to complete the Work.

All costs associated with the supply, fabrication and installation of welded end plates for closed-ended pipe piles will be considered incidental to the Work, and no separate or additional payment will be made.

##### **3.7.1.2 Pile Set-up**

Payment will be made at the unit prices bid per pile for “Pile Set-up”, for each specified type and size of piling, and will be full compensation for the supply, fabrication and installation of driving frames; pile set-up including setting the equipment over the pile ready to commence pile driving; and all labour, equipment, tools and incidentals necessary to complete the Work.

Payment will be made only once for each acceptably driven pile. All costs associated with pile set-up for pile restrikes, as determined necessary by the Consultant, will be considered incidental to the Work, and no separate or additional payment will be made.

##### **3.7.1.3 Pile Driving**

Measurement for payment of pile driving will be by the metre of piling acceptably driven and remaining in the completed structure, measured to the nearest 0.1 m.

The quantity to be paid will be the actual measured length of piling acceptably driven and remaining in the completed structure.

Payment will be made at the unit prices bid for “Pile Driving”, for each specified type and size of piling, and will be full compensation for handling; driving; splicing; cutting; and all labour, equipment, tools, and incidentals necessary to complete the Work to the satisfaction of the Consultant.

#### 3.7.1.4 Pile Tip Reinforcement

Payment will be made at the unit price bid per pile for “Pile Tip Reinforcement”, and will be full compensation for the supply and installation of pile tip reinforcements, including all labour, equipment, tools and incidentals necessary to complete the Work.

#### 3.7.1.5 Pile Splicing

~~If tolerances are not met, the Contractor shall make immediate changes to his piling procedures. Any pile out of the specified tolerance shall be corrected at the Contractor's expense to the full satisfaction of the Consultant.~~

#### 3.5.10 Measurement and Payment

Where piles penetrate 20% deeper than the design pile tip elevation shown on the Drawings, splicing will be paid for at the assigned unit price for pile splicing and will include all labour, materials, equipment, tools and incidentals necessary to complete the work. Payment for splices will be made only once for each additional 12.0 m of pile length required per pile.

The unit price for pile splicing shall be as follows:

- H-Piles: \$1,000 per splice;
- Pipe Piles: \$1,200 per splice.

#### 3.7.1.6 Restocking of Piling

When quantities of plain steel piling are reduced by 20% or more from that specified, the Department will make payment for verifiable re-stocking costs for each 12.0 m or longer length of piling incurred by the Contractor.

The Contractor shall present details including dates, quantities, supplier invoices, and all other supporting documentation requested by the Consultant. Payment will only be made at industry standard re-stocking rates, and shall be acceptable to the Consultant and the Department.

#### 3.7.1.7 Pile Concrete

Payment for pile concrete will be made in accordance with Section 4, Cast-In-Place Concrete.

All costs associated with Crosshole Sonic Logging and any associated repair work required will be considered incidental to the Work, and no separate or additional payment will be made.



3.7.1.8 Reinforcing Steel

Payment for reinforcing steel will be made in accordance with Section 5, Reinforcing Steel.

3.7.2 Drilled Cast-In-Place Concrete Piles~~3.4.1.23.~~3.7.2.1 Drill Rig Set-up

~~Payment will be made at the unit prices bid per pile for “Drill Rig Set-up will be made on the basis”, for each specified type and size of the unit price per pile bid which shall include drilled pile, and will be full compensation for setting the cost to set up the drilling equipment over the pile location ready to commence drilling, and the cost to; supply, install installation and removal of temporary casing as required. casings; and all labour, equipment, tools and incidentals necessary to complete the Work to the satisfaction of the Consultant.~~

3.7.2.2 Pile Installation

Measurement for payment of pile installation will be by the metre of drilled piles acceptably installed, measured to the nearest 0.1 m.

The quantity paid for will be the actual measured length from the pile tip to the underside elevation of the pile cap or abutment seat, as applicable.

~~Payment will be made only for piles acceptably constructed, as determined by the Consultant.~~

Pile Installation

~~Payment for at unit prices bid for “Pile Installation will be made on the basis of the unit price per lineal metre bid which shall include”, for each specified type and size of drilled pile, and will be full compensation for the cost of supplying all materials including piles, drilling, dewatering and cleaning out the drilling pile holes to the elevations and dimensions shown, on the Drawings; supply and installation of composite H-pile steel sections, if specified; removal and disposal of the augured material, pile hole tailings; detection and purging of hazardous gases; borehole camera inspection; dewatering and cleaning of pile holes as required; and all labour, equipment, tools and incidentals necessary to complete the Work to the satisfaction of the Consultant.~~

~~All costs associated with Crosshole Sonic Logging and any gas hazard, and providing safe inspection access. The quantity to be paid for **Pile Installation** shall be the number of lineal metres associated repair work required to install the piles in accordance with the drawings and specifications (measured from the pile tip to the underside of pile/pier cap). Drilling will be considered as part of pile installation incidental to the Work, and no separate or additional payment will be made.~~

~~3.4.1.33.~~3.7.2.3 Pile Concrete

~~Pile Concrete~~Payment will be ~~measured and paid for~~made in accordance with Section 4-“Cast-In-Place Concrete”.

~~3.4.1.43.1.1.1 Reinforcing Steel~~~~3.7.2.4 Reinforcing Steel incorporated in the piling~~

Payment will be ~~paid for~~made in accordance with Section 5-~~“Reinforcing Steel”~~.

~~3.6 Pile Capacity Test Methods~~~~3.7.3 3.6.1 Static Load Testing~~

Payment for static load testing will be made at the unit price bid per test for “Static Load Testing”, and will be full compensation for all labour, materials, equipment, tools and incidentals necessary to complete the testing to the satisfaction of the Consultant.

~~3.4.23.7.4 PDA Testing~~

~~When specified in the Special Provisions, the load-carrying capacity of piles shall be determined by static load tests. In general static load tests can be performed on any pile type. Static load tests shall consist of the application of a test load on a suitable platform supported by the pile, or through the use of adjacent reaction piles, with suitable apparatus for accurately measuring the test load and the settlement of the pile under each increment of load. Tests shall be in general conformance with ASTM D3689. Osterberg or Statnamic tests may be used in place of static load tests.~~

~~Where sufficient static load testing has been done to satisfy Limit State Design, Load and Resistance Factor Design (LRFD), or reliability-based design statistical requirements, the factored geotechnical resistance may be taken as 0.6. Where allowable or working state design methods are used in the design, or where the requirements of Limit State Design are not fulfilled, the allowable load shall be considered as 50% of that load which, after a continuous application of 48 hours, produces a permanent settlement not greater than 6 mm measured at the top of the pile. This maximum settlement shall not increase by a continuing application of the test load for a further period of 60 hours or longer. At least one pile for each group of 100 piles shall be tested unless a different testing frequency is specified in the Special Provisions. The frequency of testing shall be increased to account for changing soil conditions, pile sections and types, and construction methods.~~

~~3.6.2 Dynamic Load Testing / Pile Driving Analyzer (PDA) Testing~~

Dynamic Load Testing provides useful data on piling stresses and can be used as part of a quality control method during pile installation. Pile Driving Analyzer (PDA) testing can be used as an alternate or supplemental test method to static load tests for the determination of pile capacity. This method involves installing instruments on the pile head with accelerometers and strain gauges, then impacting the pile head using a pile driving hammer or similar device over a very short period of time (3-4 milliseconds). The impact imparted on the pile should be sufficient to fully mobilize the pile skin friction and end bearing resistances of the pile. In general, this requires that a net permanent set per blow of at least 3 mm (and not greater than 8 mm) be achieved upon impact from the pile hammer.

PDA testing can be conducted on either driven or cast-in-place piles. For driven piles, the PDA test shall be conducted at the end of the initial driving stage, such that the end bearing and skin friction resistances can be determined upon initial installation of the pile. Where time dependent changes in the soil conditions are anticipated, such as pile setup or relaxation, additional tests shall be conducted upon re-strike on a sample of previously tested piles to determine the bearing parameters after driving induced pore pressures have dissipated. The re-strike should be conducted approximately one to two weeks or longer after initial driving, as directed by the Consultant. It is permissible to initially drive piles to a capacity below the required ultimate capacity and rely on pile setup to produce the required capacity. Where the capacity of the pile at re-strike is relied upon for design, a minimum of one third of piles tested during initial drive should be tested again during re-strike.

If dynamic testing is only undertaken upon re-strike, then a minimum of 10% to 15% of all piles shall be PDA tested on re-strike.

The hammer energy used during PDA tests at the end of initial drive and during re-strike driving shall be such that the required ultimate pile capacity can be mobilized in a single blow without additional data interpretation.

For cast-in-place piles, the PDA test should be conducted at least one week after the installation of the pile, as directed by the Consultant.

The results of the test can be processed in the short term using the Wave Equation Analysis of Piles (WEAP) method to provide real time monitoring of pile stresses, pile integrity, hammer performance, and pile capacity; and in some cases can be used to confirm pile termination depths when borehole information is not available. This method should only be used as an initial determination of bearing capacity though, and where the test is being used to determine the capacity of the pile for design methods, a signal matching analysis using a Case Pile Wave Equation Program (CAPWAP) should be utilized.

To ensure good quality data resulting from the PDA test, ASTM D4945 should be followed. In addition, at least two accelerometers on a driven pile and four accelerometers on a cast-in-place pile should be installed. All accelerometers and transducers should be calibrated and inspected to ensure proper attachment to the pile.

~~Since the PDA test method indirectly calculates the load and settlement characteristics of the pile based on strain and acceleration measurements, PDA testing is deemed secondary in accuracy to Static Load Tests. As a result, where the PDA methods are used strictly as a QA/QC tool, a minimum of 5% to 10% of production piles should be monitored dynamically. When used as a design or confirmatory tool, a minimum of 10% to 15% of piles (including tests at such substructure associated with the project or where soil conditions are expected to vary) should be tested, or as required for statistic validation of a LRFD design whichever is greater. The piles selected for testing should be representative of other piles in the same structure. Where driven piles exhibit lower driving resistances and/or shorter penetrations than normal, or where cast-in-place piles experience extraneous soil, ground water, and/or installation conditions, additional tests over and above minimum number of tests specified earlier may be required. Further, additional tests should accompany changes in piling equipment, procedure and pile requirements.~~

~~In the situation where one pile in a pile group does not meet capacity requirements, additional tests may be necessary to confirm that this pile is an isolated case. In such case, it may be permissible to rely on group effects to compensate for the lower pile capacity. The geotechnical and structural consultants will have final say in this situation. Under no circumstances will superposition of axial and shaft capacity from different strikes, re-strikes or any combination thereof be permitted.~~

~~Where sufficient dynamic load testing has been done to satisfy Limit State Design, LRFD or reliability-based design statistical requirements, the geotechnical resistance factor for design of pile foundations may be taken as 0.5.~~

~~Pile driving equipment shall be sized such that piles can be driven with reasonable effort to the specified ultimate bearing capacity, without damaging the pile. Approval of the pile driving equipment by the Consultant will be based on the WEAP analysis and/or PDA testing. The Contractor shall submit details of the proposed pile driving equipment for review by the Consultant a minimum of 14 days prior to the commencement of pile installation. The information provided shall include the following:~~

- ~~— Hammer Data: Hammer type, manufacturer, model number, serial number, maximum rated energy and range in operating energy, stroke at maximum rated energy and range of operating stroke, ram weight, modifications.~~
- ~~— Striker Plate Data: weight, diameter, thickness, composition~~
- ~~— Hammer Cushion Data: Manufacturers, area, thickness per plate, number of plates, total thickness, and composition~~
- ~~— Helmet Data: Weight, composition~~
- ~~— Pile Cushion Data: Material, area, thickness per sheet, number of sheets, total thickness of cushion~~

~~The PDA testing agency shall prepare a daily field report summarizing the preliminary test results including driving stresses, transferred energy and estimated pile capacity to the Consultant within 24 hours of testing. The final test results shall be presented to the Department within 7 days of testing. The testing report shall be prepared in accordance with the requirements of ASTM D4945-08. As a minimum, the report shall include the following:~~

- ~~— Pile and driving system information~~
- ~~— Pile installation data~~
- ~~— PDA testing equipment and procedure~~
- ~~— Energy imparted~~
- ~~— Maximum driving stresses~~
- ~~— Hammer blow rate~~
- ~~— CAPWAP input parameters including quake and damping factors~~
- ~~— Shaft friction, end bearing and total pile capacity~~

~~The Consultant will use the test results to determine the subsequent termination criteria, requirements for modification of driving procedures or equipment, and pile acceptance. Any work done on the foundation elements (pile caps, cut-off, welding, etc) prior to received approval of test results from the Consultant will be at the Contractor's own risk.~~

### ~~3.6.3 Measurement and Payment~~

~~When the contract contains a bid item for **Static Load Testing**, payment for PDA testing will be made at the unit price bid and will be full compensation for static load testing and all labour, equipment, tools and incidentals to complete the work.~~

~~When the contract contains a bid item for **Dynamic Load Testing/Pile Driving Analyzer (PDA) Testing**, payment will be made at the unit price bid per test for "PDA Testing", and will be full compensation for dynamic load testing and **PDA Testing**, pile set up for re-strike, pile re-striking and all labour, materials, equipment, tools and incidentals necessary to complete the work.~~

~~testing to the satisfaction of the Consultant.~~



# STANDARD SPECIFICATIONS FOR BRIDGE CONSTRUCTION

## SECTION 4 CAST-IN-PLACE CONCRETE

### TABLE OF CONTENTS

<b>4.1</b>	<b>General</b> .....	<b>4-1</b>
<b>4.2</b>	<b>Materials</b> .....	<b>4-1</b>
4.2.1	Hydraulic Cement .....	4-1
4.2.2	Supplementary Cementing Materials .....	4-1
4.2.2.1	Silica Fume.....	4-1
4.2.2.2	Fly Ash .....	4-2
4.2.3	Water .....	4-2
4.2.4	Aggregates .....	4-2
4.2.5	Admixtures.....	4-2
4.2.6	Steel Fibres.....	4-2
<b>4.3</b>	<b>Storage of Materials</b> .....	<b>4-3</b>
<b>4.4</b>	<b>Class and Composition of Concrete</b> .....	<b>4-3</b>
4.4.1	Class of Concrete .....	4-3
4.4.2	Class HPC and Class HPC with Steel Fibres .....	4-4
4.4.3	Concrete Temperature at Discharge .....	4-5
4.4.4	Concrete Mix Design Submission Requirements.....	4-5
4.4.5	Trial Batches.....	4-9
4.4.5.1	Class HPC and Class HPC with Steel Fibres.....	4-9
4.4.5.2	Hydration Stabilized Concrete Mixes .....	4-10
4.4.6	Mix Adjustments.....	4-10
<b>4.5</b>	<b>Measurement of Materials</b> .....	<b>4-11</b>
<b>4.6</b>	<b>Mixing Concrete</b> .....	<b>4-11</b>
4.6.1	General.....	4-11
4.6.2	Truck Mixing .....	4-12
4.6.3	Time of Hauling.....	4-12
<b>4.7</b>	<b>Delivery</b> .....	<b>4-13</b>
<b>4.8</b>	<b>Pour Schedules</b> .....	<b>4-13</b>
<b>4.9</b>	<b>Inspection and Testing</b> .....	<b>4-13</b>
4.9.1	Compressive Strength Tests .....	4-14
4.9.2	Sampling.....	4-14
4.9.3	Test Cylinders .....	4-15
4.9.4	Slump Testing.....	4-15
4.9.5	Air Content and Density Testing.....	4-16
4.9.6	Compressive Strength Testing .....	4-16
4.9.7	Failure to Meet Slump or Air Content Specifications.....	4-16
4.9.8	Portable Batch Plants.....	4-16

<b>4.10</b>	<b>Falsework and Formwork .....</b>	<b>4-17</b>
4.10.1	General.....	4-17
4.10.2	Design.....	4-17
4.10.3	Formwork for Exposed Surfaces .....	4-18
4.10.4	Formwork for Unexposed Surfaces .....	4-19
4.10.5	Standard Details .....	4-19
4.10.6	Deck Formwork.....	4-19
<b>4.11</b>	<b>Protection of “Weathering” Steel Girders.....</b>	<b>4-20</b>
<b>4.12</b>	<b>Protection of Concrete Work and Bridge Elements from Staining .....</b>	<b>4-21</b>
<b>4.13</b>	<b>Removal of Falsework, Forms and Housing.....</b>	<b>4-21</b>
<b>4.14</b>	<b>Handling and Placing Concrete.....</b>	<b>4-22</b>
4.14.1	General.....	4-22
4.14.2	Consolidation .....	4-23
4.14.3	Additional Requirements .....	4-24
4.14.4	Pumping.....	4-24
<b>4.15</b>	<b>Placing Pile Concrete.....</b>	<b>4-25</b>
<b>4.16</b>	<b>Placing HPC Concrete and HPC Concrete with Steel Fibres.....</b>	<b>4-27</b>
4.16.1	General.....	4-27
4.16.2	Screed Guide Rails and Supports .....	4-29
4.16.3	Dry-Run .....	4-29
4.16.4	Screeding Concrete .....	4-30
4.16.5	Bull Floating/Surface Texturing .....	4-30
4.16.6	Surface Defects and Tolerances .....	4-30
<b>4.17</b>	<b>Placing Approach Slab and Roof Slab Concrete.....</b>	<b>4-31</b>
<b>4.18</b>	<b>Concreting Shear Keys and Diaphragms .....</b>	<b>4-32</b>
<b>4.19</b>	<b>Concrete Slope Protection.....</b>	<b>4-32</b>
<b>4.20</b>	<b>Construction Joints.....</b>	<b>4-33</b>
4.20.1	General.....	4-33
4.20.2	Bonding.....	4-33
<b>4.21</b>	<b>Concreting in Cold Weather .....</b>	<b>4-34</b>
<b>4.22</b>	<b>Placing Concrete under Water.....</b>	<b>4-35</b>
<b>4.23</b>	<b>Curing Concrete .....</b>	<b>4-36</b>
4.23.1	General.....	4-36
4.23.2	Curing Requirements for Concrete Slope Protection .....	4-37
4.23.3	Curing Requirements for Class HPC and Class HPC with Steel Fibres.....	4-37
<b>4.24</b>	<b>Repairing Concrete Defects.....</b>	<b>4-38</b>
4.24.1	Honeycomb, Cavities, Casting Defects .....	4-39



4.24.2	Cracks.....	4-39
<b>4.25</b>	<b>Concrete Surface Finish .....</b>	<b>4-40</b>
4.25.1	General.....	4-40
4.25.2	Class 1 Ordinary Surface Finish.....	4-41
	4.25.2.1 Unformed Surfaces.....	4-42
	4.25.2.2 Formed Surfaces .....	4-42
4.25.3	Class 2 Rubbed Surface Finish.....	4-42
4.25.4	Class 3 Bonded Concrete Surface Finish.....	4-43
4.25.5	Class 4 Floated Surface Finish .....	4-43
4.25.6	Class 5 Floated Surface Finish, Broomed Texture .....	4-44
4.25.7	Class 6 Floated Surface Finish, Surface Textured .....	4-44
4.25.8	Surface Finish under Bearings .....	4-45
4.25.9	Surface Finish under Baseplates.....	4-45
<b>4.26</b>	<b>Type 1c Sealer .....</b>	<b>4-45</b>
<b>4.27</b>	<b>Measurement and Payment .....</b>	<b>4-47</b>
4.27.1	Concrete .....	4-47
	4.27.1.1 Compressive Strength Test Result Payment Adjustment.....	4-48
	4.27.1.2 Coring.....	4-49
4.27.2	Concrete Slope Protection .....	4-50
	4.27.2.1 Compressive Strength Test Result Payment Adjustment.....	4-50



## 4.1 General

### ~~General~~

This specification ~~prescribes the quality~~ includes requirements, ~~for the production, handling, sampling and testing of the materials and concrete, the methods of producing and handling the constituent materials, the batching, mixing, handling, transporting, placing and curing as outlined, which constitute good and acceptable construction practice in structural and similar work. The Contractor shall supply all necessary materials,~~ finishing and quality of cast-in-place concrete.

~~Where Standards and Standard Specifications are referred to, the version current at time of tendering shall govern. Metric versions are inferred, when available and relevant.~~

### 4.14.2 4.2 — Materials

~~Concrete shall consist of hydraulic cement, aggregates, water and admixtures or additives which shall conform to the requirements as specified below:~~

Materials originating from outside Canada or the United States of America intended for use in the production of concrete shall be tested to the required standard by a laboratory in Canada certified to CSA A283. A verification letter shall be provided by the certified laboratory and shall include references to the appropriate mill test report(s), material specification number(s), testing date(s), and statements indicating compliance of the material to the requirements of the Contract documents. Verification letters shall be signed and sealed by a Professional Engineer.

#### 4.1.14.2.1 Hydraulic Cement

~~—~~Hydraulic cement shall conform to the requirements of CSA Standard ~~A-3004~~A3001. General Use (Normal) Type GU, or High Sulphate Resistant Type HS, or HSb shall be supplied unless otherwise specified.

As an alternative to Type HSb cement, concrete intended for placement in sulphate environments may be produced with combinations of Type GU cement and supplementary cementing materials provided current CSA A3004-C8 test data demonstrating compliance with CSA A3001 requirements for high sulfate resistance.

#### 4.2.2 Supplementary Cementing Materials

##### 4.1.1.14.2.2.1 Silica Fume

~~—Condensed~~ Silica fume shall conform to the requirements of CSA Standard ~~A-3004~~A3001 for a Type SF supplementary cementing material, with a minimum SiO<sub>2</sub> content of at least 85%, a maximum loss on ignition of 10% and ~~no more than 1%~~maximum SO<sub>3</sub> content: of 1%.

4.1.1.24.2.2.2 Fly Ash

—~~All~~ Fly ash shall conform to the requirements of CSA Standard A3001 for Type F fly ash with a maximum calcium oxide (CaO) content of 12%.

4.1.24.2.3 Water

—Water to be used for mixing concrete, approved concrete patching ~~products~~materials, or concrete finishing materials, shall conform to the requirements of CSA Standard A23.1 and shall be free from harmful amounts of alkali, organic materials or deleterious substances. The Contractor shall not use slurry water, treated wash water or water from shallow, stagnant or marshy sources.

4.1.34.2.4 Aggregates

—Fine and coarse aggregates shall conform to the requirements of CSA Standard A23.1 ~~and shall be stockpiled separately.~~

4.1.44.2.5 Admixtures

—Admixtures shall be compatible with all mix constituents. Water reducing agents and superplasticizers shall conform to ASTM C494. The addition of calcium chloride, air ~~reducing~~ agents or accelerators will not be permitted. Air entraining agents shall conform to ASTM C260.

The use of hydration stabilizing admixtures requires prior written acceptance of the Department and Consultant and their usage is limited to those projects where haul times are expected to exceed the specified times and/or projects which require hydration stabilization due to structural mass concrete placement considerations. Hydration stabilizing admixtures shall meet ASTM C494 ~~the~~ requirements ~~for of ASTM C494 Type B and/or Type D.~~

~~Type D water reducing and retarding admixtures.~~

Anti-washout admixtures shall conform to the US Army Corps of Engineers CRD-C 661.

4.1.54.2.6 Steel Fibres

—When specified, the steel fibres shall be Novocon XR, Wiremix W50 or an acceptable equivalent. The fibres shall conform to ASTM A820/A820M-04 Type 1 or 5 and be 50 mm in length with the aluminum content no more than 0.020% by mass, when tested in accordance with test method Environmental Protection Agency (EPA) 3050B.

Steel fibres shall be free from balls and clumps at all times during their use in the work.

**4.24.3 4.3 — Storage of Materials**

Cement, silica fume, fly ash and steel fibres shall be stored separately in a suitable weather -tight building which shall protect these materials from dampnessmoisture. Cement, silica fume and fly ash shall be free from lumps at all times during their use in the work. ~~The Steel fibres shall be free from balls and clumps at all times during their use in the work.~~

~~AllFine and coarse~~ aggregates shall be ~~handled so as to prevent segregation and to obtain uniformity of materials. The separated aggregates, and stored separately.~~ Aggregates secured from different sources, shall be  piled stored in separate stockpiles. The site of the stockpiles shall be cleaned of all foreign materials and shall be reasonably level and firm. If aggregates are placed directly on the ground, material ~~shall not be removed from the stockpile~~ within 150 mm of the ground level— shall not be used and this material shall remain undisturbed to avoid contaminating the aggregate being used with the ground material.

**4.4 — All aggregates shall be handled in a manner that prevents segregation.**

**4.4 — Class and Composition of Concrete**4.2.14.4.1 Class of Concrete**4.4.1 — Class Table 4-1: Classes of Concrete**

Class of Concrete <sup>(4)</sup>	Minimum Specified Compressive Strength at 28 Days (MPa)	Nominal Maximum Aggregate Size(mm)	Range of Slump <sup>(6)</sup> (mm)	Total Air Content <sup>(5)</sup> (%)	Max. Water / <u>Cementing Materials Ratio</u>
C	35	20 to 5 <sup>(1)</sup>	100 ±30	5 - 8	0.40
HPC <sup>(3)</sup>	45	20 to 5 <sup>(2)</sup>	120 ±30	5 - 8	0.38
D	30	14 to 5	100 ±30	5 - 8	0.42
S	20	<del>28</del> 20 to 5 <sup>(1)</sup>	100 ±30	<del>4-75</del> - 8	0.50
Pile	30	<del>28</del> 20 to 5 <sup>(1)</sup>	130 ±30	<del>4-75</del> - 8	0.42

**Notes**

- (1) ~~The size of 28 to 5 mm nominal maximum~~ coarse aggregate shall size may be 28 to 5 mm utilized for Class C, Class S, or Pile concrete when used in and shall be considered for mass pours such as piers and abutments concreting operations.
- (2) When the thickness of deck overlay concrete is specified as 50 mm or less, the nominal maximum top size of aggregate shall be 14 mm.

- (3) Class HPC concrete shall be used for all decks, deck overlays with internal reinforcement, curbs, barriers, medians, roof slabs, deck joint blockouts, approach slabs and MSE wall coping. Deck overlay concrete shall be Class HPC with steel fibres when no internal reinforcement exists.
- (4) ~~The~~ Fly ash shall not exceed 30% by mass of cementing materials. For High Performance Concrete (HPC) it shall be in accordance with 4.4.2-Subsection 4.4.2, Class HPC and Class HPC with Steel Fibres. Fly ash may be used in concrete mixes where the aggregate is assessed to be potentially alkali-silica reactive.
- (5) Range in air content to be in compliance with actual nominal maximum aggregate size as per Category 1, CSA A23.1 Table 4, Requirements for Air Content Categories.
- (6) Slump ranges proposed by the Contractor that are outside those specified require acceptance from the Department.
- (7) For MSE Wall panels, smaller aggregate may be required to suit panel design.
- (8) Additional requirements for Class HPC and Class HPC with Steel Fibres are listed in Section 4.4.2-Subsection 4.4.2, Class HPC and Class HPC with Steel Fibres.
- (9) 4.4.2—Sulphate resistance or other required durability properties will be outlined in the Special Provisions of the Contract.

#### 4.4.2 Class HPC and Class HPC with Steel Fibres

##### Class HPC and Class HPC with Steel Fibres shall meet the following requirements:

- (a) ~~(a)~~—Mix shall include silica fume and fly ash as supplementary cementing materials in combination with compatible air entraining, water reducing and/or superplasticizing admixtures, as required.
- (b) ~~(b)~~—The gradation limits for the fine aggregate shall conform to CSA A23.1, except that the amount of material finer than 160 µm shall not exceed 5%.
- (c) ~~(c)~~—Coarse aggregate shall conform to CSA A23.1 and the maximum combination of flat and elongated particles (4:1 ratio), as determined by CSA A23.2-13A, {Procedure A}, shall not exceed 10% of the mass of coarse aggregate.
- (d) ~~(d)~~—Minimum type GU cement content (excluding supplementary cementing materials) shall be 335 kg/m<sup>3</sup>. Type HS cement shall not be used.
- (e) ~~(e)~~—Sum of silica fume and fly ash by mass of cementing materials shall be 17% to 20%.
- (f) ~~(f)~~—Silica fume by mass of cementing materials shall be 6% to 8%.
- (g) ~~(g)~~—Fly ash by mass of cementing materials shall be 11% to 15%.

- (h) ~~(h)~~ — Resistance to chloride ion penetration shall be determined in accordance with ASTM C1202 on duplicate laboratory moist cured samples at 28 days. The average of all tests shall not exceed 1000 coulombs with no single test greater than 1250 coulombs. When only two test values are used to calculate the average coulomb rating, no test shall exceed 1000 coulombs. For HPC with steel fibres, testing shall be done without the presence of steel fibres.
- (i) ~~(i)~~ — An air-void spacing factor shall be determined in accordance with ASTM C457, modified point-count method at 100 times magnification. The average of all tests shall not exceed 230  $\mu\text{m}$  with no single test greater than 260  $\mu\text{m}$ . When only two test values are used to calculate the average air-void spacing factor, no test shall exceed 230  $\mu\text{m}$ .
- (j) ~~(j)~~ — When Class HPC with steel fibres is specified, it shall contain 60 kg of 50 mm long steel fibres, per  $\text{m}^3$ . The Contractor shall provide test results of the aluminum content in the steel fibres, for the consultants review, a minimum of two weeks prior to placing concrete at site. When alternative steel fibres are proposed their equivalency and dosage rate shall be determined in accordance with ASTM C1609. The toughness ( $T_{600}^D$ ) shall be greater than or equal to that determined for the specified fibre type and dosage rate.

#### 4.2.24.4.3 ~~4.4.3~~ Concrete Temperature at Discharge

The concrete temperature shall be between 10°C and 20°C, at discharge for Class HPC and Class HPC with steel fibres. The concrete temperature at discharge shall be between 10°C and 25°C for all other classes of concrete.

#### 4.2.34.4.4 ~~4.4.4~~ Concrete Mix Design and Aggregate Testing Submission Requirements

The Contractor shall submit a concrete mix design review letter for each class of concrete ~~including applicable material test reports specified in the Contract~~ for the Consultant's review and acceptance a minimum of two weeks before concrete placement. A concrete mix design ~~and material test reports are~~ review letter is not required for concrete used in the construction of culvert collars or cut-off walls when culverts are less than ~~3~~ three metres in diameter.

~~The Concrete mix design review letters shall document compliance with all specification requirements for the associated class of concrete including an evaluation and summary of all mix constituents, material test reports, mix proportion quantities, and if applicable, trial batch test results, mass concrete design considerations, and portable batch plant batching procedures. The concrete mix design review letter shall be signed and sealed by a Professional Engineer registered in the Province of Alberta who is employed by a concrete testing laboratory certified to CSA A283.~~

~~When concrete suppliers request confidentiality of mix proportion quantities, the reviewing Professional Engineer, subject to a mutually agreeable confidentiality agreement with the concrete supplier, shall be granted full disclosure of mix proportion quantities such that a general mix proportioning discussion can be provided in the mix design review letter.~~

If in the Special Provisions of the Contract mass concrete mitigation measures are required, the Contractor shall develop and submit a mass concrete plan to the Consultant for review and acceptance. The mass concrete plan shall be submitted a minimum of two weeks before concrete placement and be signed and sealed by a Professional Engineer registered in the Province of Alberta. The mass concrete plan and the proposed mitigation measures shall be developed and consistent with the technical requirements outlined in the American Concrete Institute (ACI) 207.4R "Cooling and Insulating Systems for Mass Concrete". The mass concrete plan shall also describe the performance monitoring requirements and on-site response strategies to address varying thermal conditions.

Material test reports shall be current and fully represent materials to be used in production. For each mix design submission the source(s) of proposed aggregate(s) and aggregate analysis shall be provided as required in Table 4-2: Aggregate Analysis.

**Table 4-2: Aggregate Analysis**

<b><u>Aggregate Analysis</u></b>	<b><u>Standard</u></b>	<b><u>Required Frequency of Analysis (max. days prior to &amp; during production)</u></b>
<u>Fine and Coarse Aggregate Sieve</u>	<u>(CSA A23.2-2A) <sup>(2)</sup></u>	<u>90</u>
<u>Amount of material finer than 80 µm in aggregate</u>	<u>(CSA A23.2-5A) <sup>(2)</sup></u>	<u>90</u>
<u>Organic Impurities in Sands for Concrete</u>	<u>(CSA A23.2-7A) <sup>(2)</sup></u>	<u>90</u>
<u>Results of deleterious substances and physical properties of aggregates</u>	<u>(CSA A23.1 Table 12, CSA A23.1; A23.2-3A, A23.2-4A, A23.2-13A {Procedure A}, A23.2-23A, A23.2-24A A23.2-29A) <sup>(1)</sup></u>	<u>180</u>
<u>Potential expansivity of aggregates</u>	<u>(CSA A23.2-14A) <sup>(1)</sup></u>	<u>24 months</u>
<u>Detection of alkali-silica reactive aggregate by accelerated expansion of mortar bars</u>	<u>(CSA A23.2-25A) <sup>(1)</sup></u>	<u>12 months</u>
<u>Petrographic Examination of Coarse and Fine Aggregate for Concrete</u>	<u>(CSA A23.2-15A) <sup>(1)</sup></u>	<u>180</u>



Notes:

- (1) Sampling and testing of aggregates shall be completed by a concrete testing laboratory certified to CSA A283. ~~Concrete mix designs, including the review of all material test reports, shall be signed and sealed by a Professional Engineer registered in the Province of Alberta employed by a concrete testing laboratory certified to CSA A283. The Engineer shall also provide a professional opinion indicating that the concrete mix is suitable for the intended use and can be expected to meet specification requirements.~~

~~Alternatively, concrete mix designs, including the~~ Sampling and testing of aggregates and review of material test reports may be completed by a qualified professional employed by the concrete supplier. When the concrete mix design is completed by the concrete supplier it shall be reviewed for compliance with the respective specifications, signed and sealed by a Professional Engineer registered in the Province of Alberta employed by an independent concrete testing laboratory certified to CSA A283. ~~The independent review Engineer shall also provide a professional opinion indicating that the concrete mix is suitable for the intended use and can be expected to meet specification requirements.~~

- (2) ~~Material test reports shall be current and fully represent materials to be used in production. For each mix design submission the source(s) of proposed or by the aggregate(s) and following aggregate analysis shall be provided: supplier.~~

Aggregate Analysis	Standard	Required Frequency of Analysis (maximum days prior to production)
Fine and Coarse Aggregate Sieve	(CSA A23.2-2A)	90
Amount of material finer than 80 µm in aggregate	(CSA A23.2-5A)	90
Organic Impurities in Sands for Concrete	(CSA A23.2-7A)	90
Results of deleterious substances and physical properties of aggregates	(Table 12, CSA A23.1; A23.2-3A, A23.2-4A, A23.2-23A, A23.2-24A A23.2-29A)	180
Potential expansivity of aggregates	(CSA A23.2-14A)	24 months

Aggregate Analysis	Standard	Required Frequency of Analysis (maximum days prior to production)
<del>Detection of alkali-silica reactive aggregate by accelerated expansion of mortar bars</del>	<del>(CSA A23.2-25A)</del>	12 months
Petrographic Examination of Coarse Aggregate for Concrete	(CSA A23.2-15A)	180

~~A break in production of a particular class of concrete shall not constitute the need for additional testing when the Contractor provides aggregate sieve analysis, organic impurities in sands for concrete, petrographic examination of aggregates, and letter of evaluation from the mix design review letter professional indicating that the material initially tested is still representative.~~ Additional analyses shall be provided by the Contractor when requested by the Consultant to confirm that the mix constituents continue to meet specification requirements. ~~A break in production of a particular class of concrete shall not constitute the need for additional testing when the Contractor provides conclusive evidence that the material initially tested is still representative.~~

If the fine aggregate consists of a blend from more than one source, the ~~“Fine Aggregate Sieve”~~fine aggregate sieve analysis shall show the gradation of the blended fine aggregates. Similarly in the case of blended coarse aggregates, the ~~“Coarse Aggregate Sieve”~~coarse aggregate sieve analysis shall indicate the gradation of the blended coarse aggregates.

Fine aggregate, tested in accordance with CSA Test Method A23.2-7A, “Organic Impurities in Sands for Concrete”, shall produce a colour not darker than the Standard colour (Organic Plate Number 3). Aggregate producing a colour darker than the Standard colour will be rejected in the absence of a satisfactory record of performance of a similar CSA exposure class of concrete (minimum 30 tests over the last 12 months); provisions 4.2.3.3.3.2 (a) & (b) of CSA Standard ~~CAN3-CAN~~ A23.1-04-14 shall not apply. When testing in accordance with CSA Test Method A23.2- 2A and 5A fine aggregate shall not have more than 3.0% passing 80 µm sieve.

The potential for deleterious alkali-aggregate reactivity shall be assessed in accordance with CSA A23.2-27A. Test data less than 24 months after date of sampling shall be used to evaluate the potential alkali-silica reactivity of aggregates tested in accordance with CSA A23.2-14A or CSA A23.2-25A. Testing in accordance with CSA A23.2-28A may be utilized as part of the alkali-aggregate reactivity assessment. In the absence of test data, the aggregate shall be presumed to be highly reactive. The level of risk for alkali-aggregate reactivity assessment shall be for concrete exposed to humid air and the design service life shall be greater than or equal to 75 years (St4).

Petrographic analysis on the proposed fine and coarse aggregates shall be performed in accordance with CSA A23.2-15A by experienced personnel employed by a laboratory certified to CSA A283. The weighted petrographic number of the coarse aggregate shall not exceed 130, and the ironstone content shall not exceed 0.8%. Ironstone content in fine aggregate (material retained on the 2.5 mm sieve) shall not exceed 1.5% by total dry mass of fine aggregate for all classes of concrete except pile concrete.

~~The potential for deleterious alkali-aggregate reactivity shall be assessed in accordance with CSA A23.2-27A. This assessment shall include the risk level associated with structure size and environment, the level of prevention related to service life requirements and the determination of the appropriate preventative measures, including testing in accordance with CSA A23.2-28A. For bridge structures, the design service life is considered to be 75 years. Current test data evaluating the potential alkali-silica reactivity of aggregates tested in accordance with CSA A23.2-14A or CSA A23.2-25A is required. In the absence of current test data, the aggregate shall be presumed to be highly reactive.~~

~~Petrographic analysis on the proposed coarse aggregates shall be performed in accordance with CSA A23.2-15A by experienced personnel employed by a laboratory certified to CSA A283. The (weighted) petrographic number shall not exceed 130, and the ironstone content shall not exceed 0.8%.—The petrographic analysis report shall be signed and sealed by either a Professional Engineer, a Professional Geologist, or a Geological Engineer who is registered in the Province of Alberta.~~

#### 4.2.44.4.5 ~~4.4.5~~—Trial Batches

The Contractor is required to complete trial batch(es) for Class HPC, Class HPC with Steel Fibres, ~~and/or~~ any class of concrete containing hydration stabilizing admixtures, and/or any class of concrete produced from a portable batch plant. The Contractor shall produce evidence satisfactory to the Consultant and the mix design reviewing Professional Engineer that the proportions selected will produce concrete of the quality specified. The trial batch(es) shall be performed a minimum of 35 days prior to placement of concrete at site. Each trial batch shall be a minimum of 3 m<sup>3</sup> or 50% of the rated mixer capacity (whichever is greater). The Contractor's quality representative shall attend all trial batches. For multi-year projects, all trial batch testing shall be repeated ~~in conjunction with required aggregate testing~~ annually.

#### 4.2.4.14.4.5.1 (a) —Class HPC and Class HPC with Steel Fibres

Slump retention shall be evaluated at 15, 30, 50, and 70 minutes after batching. Slump retention after 50 minutes shall be at least 50% of that measured at 15 minutes.

At 70 minutes from the time of batching, samples shall be cast to determine compressive strength at 7 and 28 days, rapid chloride ion penetration, and hardened air void system in accordance with the requirements of ~~Section 4.4.2.~~ Subsection 4.4.2, Class HPC and Class HPC with Steel Fibres.

Shrinkage of the trial batch concrete shall be measured in accordance with CSA A23.2-21C. Shrinkage test results shall be submitted to the Consultant within seven days of test completion.

~~(b) —~~ The trial batch concrete shall be placed into a 4.5 m x 4.5 m x 0.15 m thick form on grade. The Contractor shall consolidate, screed and finish the concrete such he can assess the mix's workability, finishability in accordance with all specification requirements.

#### 4.2.4.24.4.5.2 Hydration Stabilized Concrete Mixes

The design length of hydration stabilization shall be the difference of the project haul time and the specified allowable haul time (not exceeding 90 minutes) or that required by ~~structural~~ mass concrete pour considerations. The hydration stabilized mix design, including a detailed concrete batching procedure, shall be submitted and reviewed in accordance with ~~Section 4.4.4.~~ Subsection 4.4.4, Concrete Mix Design Submission Requirements. The Contractor shall also submit a placement, finishing, and curing procedure with associated schedule details for the Consultants review and acceptance. Hydration stabilized concrete mixes demonstrating significant inconsistencies, as determined by the Consultant, shall require additional trial batch testing to demonstrate compliance.

~~The time of initial and final set, compressive strength at 3, 7, and 28 days and hardened air void system shall be determined. Hardened air void systems shall meet the requirements of Section 4.4.2 (i). Slump retention~~ Workability including, slump and air content, shall be assessed at 15 minutes after batching, quarter points of the design hydration stabilization period and ~~30 minutes prior to the anticipated initial set at the design period.~~ Testing to determine setting characteristics, compressive strength at 3, 7, and 28 days and hardened air void system shall be completed. Setting characteristics shall be determined in accordance with ASTM C403 and the time required to achieve penetration resistances of 0.5 MPa, 1.0 MPa and 3 MPa reported. Hardened air void systems shall meet the requirements of Subsection 4.4.2 (i), Class HPC and Class HPC with Steel Fibres. Trial batch(es) of Class HPC and Class HPC with steel fibres shall also meet the requirements for rapid chloride permeability ~~and submission of shrinkage test.~~ Shrinkage results shall be provided to the Consultant within seven days of test completion.

#### ~~4.2.54.4.6~~ 4.4.6 — Mix Adjustments

If during the progress of the Work the ~~initial approved~~ concrete produced in accordance with the reviewed and accepted mix design is modified or found to be unsatisfactory ~~for any reason~~ on the basis of specification requirements, the Contractor shall resubmit a revised mix design review letter, in accordance with the requirements of ~~Section 4.4.4.~~ Subsection 4.4.4, Concrete Mix Design Submission Requirements, to the Consultant for review and acceptance prior to continuing concrete operations. Discussion on the requirement for a new trial batch to address the issues identified shall be included in the revised mix design review letter.

**4.34.5 4.5 — Measurement of Materials**

Coarse and fine aggregate materials shall be separated and measured separately by weighing, except as otherwise specified or where other methods are specifically authorized by the Consultant. The apparatus provided for weighing the aggregates and cement shall be suitably designed and constructed for this purpose. Each size of aggregate, and ~~the cement~~ **cementing materials**, shall be weighed separately. The accuracy of all weighing devices shall be such that successive quantities can be measured to within one percent of the desired amount. The mixing water shall be measured by volume or by weight. The water measuring device shall be capable of control accurate to  $\pm 0.5\%$  of the design quantity. All measuring devices shall be subject to acceptance. Unless otherwise accepted, air entraining agent and other admixtures shall be added to the mix in a water ~~-diluted~~ solution; the dilution of the solution shall be accepted by the Consultant. For mix adjustments at the site, the Contractor shall maintain facilities to control the amount of superplasticizer and air entrainment so that the required tolerances can be met.

**4.44.6 4.6 — Mixing Concrete****4.4.14.6.1 4.6.1 — General**

Mobile continuous mixers or other such volumetric concrete supply equipment shall not be used.

All Portable batch plants may only be used when reviewed and accepted by the Consultant and the Department. A comprehensive batching procedure shall be submitted to and reviewed by the mix design review professional in accordance with Subsection 4.4.4, Concrete Mix Design Submission Requirements. The concrete production rate shall be provided with the batching procedure.

Concrete shall be mixed thoroughly with all ingredients uniformly distributed. The Consultant may require that the uniformity of the mixed concrete be tested for conformance with CSA A23.1, Clause 5.2.3.5. The "Batch" is considered ~~as~~ the quantity of concrete inside the mixer regardless of size of the mixer. The mixing period shall be measured from the time materials enter the mixing drum.

The Contractor shall in no case load the mixer above its rated capacity. The Contractor shall maintain the mixer in good condition. Inner surfaces of the mixer shall be kept free of hardened concrete and mortar. Mixer blades which are bent or worn down so as to affect the mixing efficiency shall be renewed. Any mixer, leaking mortar or causing waste of materials through faulty charging shall be taken out of service until repaired. The Contractor shall, at all times, operate the mixer at the speed recommended by the Manufacturer and shall, if requested, supply the Manufacturer's certification of the mixing capacity of the machine in use.

The mixer shall be fitted with an accurate and dependable means for measuring the water added, which is not affected by variation in pressure in the water supply line. All joints, valves and other parts shall be maintained so that there is no leakage of water into the mixer drum. Failure of the Contractor to have an accurately working and dependable water gauge on a mixer shall be cause for the Consultant to prohibit the mixer to be used.

Water shall be released first and continue to flow while other materials are entering the mixer. The water discharge pipe shall be so arranged and be of such size that the flow into the mixer is completed within the first quarter of the mixing time, and the water is delivered well within the mixer where it will be quickly mixed with the entire batch.

Air entraining agents and admixtures shall be placed in the mixer after the initial water is in the mixer drum but before the remaining materials are added. Superplasticizer shall be added after initial mixing and as per the Manufacturer's recommendation.

#### 4.4.24.6.2 ~~4.6.2~~—Truck Mixing

Truck mixers, unless otherwise authorized by the Consultant, shall be of the revolving drum type, watertight, and so constructed that the concrete can be mixed to ensure uniform distribution of materials throughout the ~~massbatch~~. All materials for the concrete shall be accurately measured in accordance with ~~Section 4.5, Subsection 4.5, Measurement of Materials~~ and charged concurrently into the drum at the production plant, at the proportions satisfying the accepted mix design. Increases in the water to cementitious materials ratio will not be permitted.

Maximum size of the batch in truck mixers shall not exceed the maximum rated capacity of the mixer as stated by the manufacturer and stamped on the mixer. Truck mixing shall commence immediately upon introduction of ingredients into the drum and be continued for at least 70 revolutions with the mixing rate being in accordance with the Manufacturer's recommended rate, and shall be such as to thoroughly mix the concrete.

When adjustment to the mix by adding air entraining agent or superplasticizer at the site is authorized by the Consultant, the mixer shall rotate for a minimum of 70 additional revolutions to ensure homogeneity of the concrete before discharge. Discharge chutes shall be kept clean and free from hardened concrete and shall be ~~wetted down~~wet prior to use.

#### 4.4.34.6.3 ~~4.6.3~~—Time of Hauling

The maximum time allowed for all classes of concrete other than Class HPC and Class HPC with steel fibres including delivery to the site of the work and discharge shall not exceed 90 minutes after batching. For Class HPC and Class HPC with steel fibres this requirement is reduced to 70 minutes. In hot weather, or under conditions that accelerate setting of the concrete, these haul times may be reduced as determined by the Consultant. Batching of all classes of concrete is considered to occur when any of the mix ingredients are introduced into the truck mixer drum, regardless of whether or not the drum is revolved. ~~For Class HPC and Class HPC with steel fibres this requirement is reduced to 70 minutes. In hot weather, or under conditions contributing to quick setting of the concrete, these haul times may be reduced as determined by the Consultant and such deviations will be addressed in the Special Provisions.~~

**4.54.7 4.7 — Delivery**

The Concrete supplier shall have sufficient plant capacity and satisfactory transporting equipment to ensure continuous delivery at the rate required. The rate of delivery of concrete during concreting operations shall be such that ~~the development of~~ cold joints ~~does do~~ not occur. The methods of delivering and handling the concrete shall facilitate placing with a minimum of re-handling, and without damage to the structure or the concrete.

**4.64.8 4.8 — Pour Schedules**

The Contractor shall inform to the Consultant of the proposed pour schedule ~~for any particular pour and production rates for all concrete pours.~~ If, in the opinion of the Consultant, the ~~amount of pour size is deemed~~ larger than can be poured with the methods proposed, the Contractor shall ~~either~~:

- ~~(a) —~~ Limit the amount to be poured at any time (using adequate construction joints);~~;~~ or
- ~~(b) —~~ ~~Augment~~Adjust his facilities in order to complete the proposed pour;~~;~~ or
- ~~(c) —~~ In case of continuous pouring, provide additional crews and have adequate lighting to facilitate proper placing, finishing and inspection.

**4.74.9 4.9 — Inspection and Testing**

The Consultant shall be afforded full facilities for the random quality assurance inspection and testing that may be carried out relative to the concrete itself and/or the constituent materials. This includes at the worksite and any plant used for the manufacture of concrete wherever this may be situated. The facilities shall be adequate in the opinion of the Consultant to permit proper sampling of concrete, making of test cylinders and testing slump and air content. The proper storage of all site cast concrete cylinders in accordance with the relevant specifications is the responsibility of the Contractor.

The results of the quality assurance testing carried out by the Consultant will serve to monitor and review the quality control program of the Contractor.

The Contractor shall utilize ACI or CCIL/CSA certified testers with extensive related experience to test at site, the air content, density, slump and temperature of each batch; results of all such tests shall be provided to the Consultant. Additional tests will be required if the results are borderline or widely variable. In case of an unacceptable result, one check test will be permitted. The certified testers shall also cast the test cylinders as specified in ~~section 4.9.3 "Test Cylinders"~~. Subsection 4.9.3, Test Cylinders.

The certified testers shall utilize the "Concrete Test Results" form contained at the end of this Section. ~~4, Cast-In-Place Concrete.~~ The completed forms shall accompany the concrete test cylinders to the testing laboratory.

The certification of the testers shall be current and available for examination by the Consultant.

4.9.1—The Contractor shall be responsible for all costs for concrete inspection and testing, including but not limited to making and curing test cylinders, transporting cylinders to an independent certified testing laboratory of his choice, storage, curing, strength testing, and providing written reports of the concrete test results to the Consultant.

#### 4.7.14.9.1 Compressive Strength Tests

A "~~Strength Test~~" compressive strength test shall consist of the ~~compression tests of~~ four standard test specimens, sampled, made, cured, and tested in accordance with CSA ~~Standard Specifications~~ Standards and as modified herewith. One cylinder shall be tested at ~~seven~~ 7 days. The 28 day test result shall be the average of the strengths of the remaining three specimens, except that if any specimen in a test showing distinct evidence of improper sampling, moulding or testing, shall be discarded and the remaining strengths averaged. Additional cylinders may be cast, at the discretion of the Consultant or Contractor.

For Class HPC ~~and Class HPC with steel fibres,~~ the Contractor shall take a compressive strength test to represent each approximate 20 m<sup>3</sup> portion of the concrete pour, to a minimum of one compressive strength test for every two batches of concrete. For Class HPC with steel fibres the Contractor shall take a compressive strength test to represent each approximate 5 m<sup>3</sup> portion of the concrete pour or one compressive strength test for every batch of concrete, whichever is less. For all other concrete, the Contractor shall take a compressive strength test to represent each bridge element or portion of the element (i.e. abutment seat, abutment backwall, pier footing, pier cap etc.). On larger pours, a compressive strength test will be taken to represent each approximately 30 m<sup>3</sup> portion of the concrete pour, to a minimum of one compressive strength test for every three batches of concrete. Such tests shall be taken from representative batches as determined by the Consultant.

#### 4.7.24.9.2 4.9.2—Sampling

Sampling of concrete shall be carried out in accordance with CSA Standard A23.2 -1C, Sampling Plastic Concrete. When a concrete pump is used to place concrete, sampling shall be at the end of the discharge hose with the exception that when concrete is being placed underwater by tremie methods, sampling may occur at the pump's hopper.



~~4.7.34.9.3~~ ~~4.9.3~~—Test Cylinders

Making and curing concrete test cylinders shall be carried out in accordance with CSA Standard A23.2-~~3C~~ 3C, Making and Curing Concrete Compression and Flexural Test Specimens, except that the time for cylinders to reach the testing laboratory shall be between 20 and 48 hours. The test cylinders shall be cast by the Contractor in standard CSA approved heavy duty steel or plastic moulds. Plastic moulds shall have a wall thickness of at least 6 mm. The Contractor shall provide properly designed temperature-controlled storage boxes for test cylinders, as specified in ~~Section~~Subsection 8.3.2.1 of CSA Standard A23.2 -3C, Making and Curing Concrete Compression and Flexural Test Specimens, for a period of ~~at least~~not less than 24 hours, and further protection, as required, from adverse weather and mishandling until removed from the site. The Contractor shall provide a max-min thermometer for each storage box and record site curing temperatures for all test cylinders. Storage in a portable building which will be used by Contractor's personnel or the Consultant during the first 24 hour storage period will not be permitted. Storage facilities shall be provided, installed, and accepted by the Consultant before any concrete is placed.

The Contractor shall be responsible to deliver the test cylinders to an independent CSA certified testing laboratory. Handling and transporting of the cylinders shall be in accordance with CSA Standard A23.2 -3C-, Making and Curing Concrete Compression and Flexural Test Specimens. No extra laboratory curing time ~~will~~shall be allowed for cylinders that are delivered late to the laboratory. For Class HPC and HPC with steel fibres, the ends of cylinders shall be ground flat prior to testing. A copy of the test results shall be forwarded to the Consultant and Concrete Producer within 2 days of the break date.

If the test cylinders exhibit frost etchings or were stored at temperatures below 10°C or above 25°C, or are otherwise mishandled resulting in unreliable compressive strength test results, the Department or Consultant may reject these portions of the Work, unless core ~~-~~testing, at the Contractor's expense confirms the in -situ strength of the concrete.

~~The Contractor shall be responsible for all costs for concrete testing, including but not limited to making and curing test cylinders, transporting cylinders to an independent certified testing laboratory of his choice, storage, curing, strength testing, and providing written reports of the concrete test results to the Consultant.~~

The Contractor shall also be responsible for costs for supplying CSA approved heavy duty steel or plastic moulds, curing and delivering test cylinders cast by the Consultant, for quality assurance purposes to the same independent certified testing laboratory that he selects. Quality assurance testing may be carried out by the Consultant and costs for testing and provision of concrete test cylinder reports will be paid for by the Department.

~~4.9.4~~—Slump

4.9.4 Slump Testing

Slump tests shall be ~~conducted~~carried out in accordance with CSA Standard A23.2 -5C.

~~4.7.44.9.5~~ 4.9.5—Air Content and Density Testing

Air content and density ~~test~~testing shall be ~~conducted~~carried out in accordance with CSA Standard A23.2 4C and A23.2 6C respectively.

4.9.6 Compressive Strength Testing

Compressive strength testing shall be carried out in accordance with CSA Standard A23.2 ~~4C and A23.2-6C respectively.~~

~~4.9.6—Testing Cylinders~~

~~Test cylinders will be tested in compression in accordance with CSA Standard A23.2-9C~~ by an independent CSA certified engineering laboratory engaged by the Contractor.

~~4.7.54.9.7~~ 4.9.7—Failure to Meet Slump or Air Content Specifications

In the event that slump and/or air content are outside the specified tolerance range, as determined by the Contractor's or the Consultant's testing, the Consultant may, accept adjustments of the deficient condition as an alternate to rejection provided adjustments are made within the maximum time allowed as specified in ~~section 4.6.3—“Time of Hauling”~~Subsection 4.6.3, Time of Hauling. Concrete that does not meet the specifications will be rejected after the maximum time is exceeded.

The Contractor will be allowed to adjust only the quantities of superplasticizer and air entraining agent. In no case shall an accepted batch adjustment relieve the Contractor of his responsibility for the eventual durability, strength, and acceptability of the concrete concerned. The Department or Consultant reserves the right to reject any batch in the event of confirmed unacceptability, and to require immediate removal of any rejected concrete which might have already been placed in the structure.

4.9.8 4.10—Portable Batch Plants

The Contractor shall provide full time experienced and competent personnel to operate, maintain and continuously monitor portable batch plant operations.

The Contractor shall provide the qualifications of the portable batch plant supervisor to the Consultant for review and acceptance. The portable batch plant supervisor shall monitor concrete production at the portable batch plant at all times.

#### 4.8.10 Falsework and Formwork

##### 4.8.14.10.1 ~~4.10.1~~ General

Detailed falsework and formwork drawings shall be supplied to the Consultant for review and examination as to concept only. The drawings shall be submitted three weeks before construction commences. The drawings shall ~~bear the Seal of~~ be sealed by a Professional Engineer registered in the Province of Alberta, who shall assume full responsibility to ensure that his design is being followed in construction of the falsework and formwork. Compliance with the Occupational Health and Safety Act and Regulations therein, shall be integral parts of the design. All falsework and formwork shall be fabricated in accordance with the drawings.

The Contractor shall make every effort to accurately position formwork against hardened concrete so as to avoid form lines and discontinuities at the construction joint. Construction tolerances for formwork misalignments are outlined in ~~Section 4.25.8-Subsection 4.24.1, Honeycomb, Cavities, Casting Defects.~~

##### ~~4.10.2 Design~~

##### 4.10.2 Design

For the design of falsework and formwork, the density of fresh concrete shall be assumed to be 2400 kg/m<sup>3</sup>. All forms shall be of wood, metal or other acceptable materials, and shall be designed and built mortar -tight and of sufficient rigidity to prevent distortion due to the pressure of vibrated concrete and other loads incidental to the construction operation. The forms shall be substantial and unyielding, and shall be designed so that ~~finished~~ hardened concrete will conform to the design dimensions and ~~contours~~ alignments. The shape, strength, rigidity, water tightness and surface smoothness of re -used forms shall be maintained at all times. Any warped or bulged formwork must be repaired or replaced before being used. Forms which are unsatisfactory in any respect shall not be used.

All falsework shall be designed and constructed to provide the necessary rigidity and to support the loads without appreciable settlement or deformation. Falsework which cannot be founded on a satisfactory footing shall be supported on piling which shall be spaced, driven and removed in a manner acceptable to the Consultant.

For timber formwork, drawings shall specify the type and grade of lumber and show the size and spacing of all members. The formwork drawings shall also show the type, size and spacing of all ties or other hardware, and the type, size and spacing of all bracing.

When forms appear to be unsatisfactory in the opinion of the Consultant, either before or during the placing of concrete, the Consultant will order the work stopped until the defects have been corrected.

For narrow walls and columns, where the bottom of the form is inaccessible, removable panels shall be provided in the bottom form panel to enable cleaning out of extraneous material immediately before placing the concrete.

4.8.24.10.3 ~~4.10.3~~ Forms~~Formwork~~ for Exposed Surfaces

~~Forms~~Formwork for exposed surfaces which require a Class 1 ~~“~~“Ordinary Surface Finish~~”~~”, shall be made of good quality plywood, or an acceptable equivalent, of uniform thickness, with or without a form liner. ~~Forms~~

Formwork for exposed surfaces requiring a Class 2 ~~“~~“Rubbed Surface Finish~~”~~” or Class 3 ~~“~~“Bonded Concrete Surface Finish~~”~~”, shall be all new material, made of ~~“~~“Coated Formply~~”~~”, ~~coated formply~~, consisting of Douglas Fir substrate with resin-impregnated paper overlay and factory treated chemically active release agent. ~~“~~“ULTRAFORM~~”~~”, or ~~“~~“POURFORM 107~~”~~”, ~~are acceptable formwork panels, however other forming panels will be considered if approved equal.~~ ~~All form material for exposed surfaces shall be full-sized sheets, as practical.~~ ~~The re-use of any forms must have the acceptance of the Consultant~~Formwork proposed for re use shall be free of holes or patched holes in plywood or form liner surfaces, bulging, delaminations, damage, or other imperfections that affect the trueness of the formed concrete surfaces.

Any proposed re use of formwork must be accepted by the Consultant.

All ~~forms~~formwork material for exposed surfaces shall be full sized sheets, as practical.

All formwork for exposed surfaces shall be mortar -tight, filleted at all sharp corners, and given a bevel or draft in the case of all projections. At the top edges of exposed surfaces, the chamfers are to be formed by chamfer strips.

~~The minimum acceptable forming for all~~For exposed concrete elements where the pour height is 1.5 m or less ~~is, the minimum formwork requirements shall be~~ 18 mm approved plywood supported at 300 mm maximum on centres. Where the pour height is greater than 1.5 m, ~~the minimum acceptable forming for all exposed concrete~~formwork requirements shall ~~have~~be 18 mm approved plywood, “Coated Formply”, supported at 200 mm maximum on centres. The support spacing specified here ~~assumes~~assumes the use of new material. Closer spacing may be required in case of re -used material. Strong -backs or walers placed perpendicularly to the supports shall be employed to ensure straightness of the form.

Metal bolts or anchorages within the forms shall be so constructed as to permit their removal to a depth of at least 20 mm from the concrete surface. Break -back type form ties shall have all spacing washers removed and the tie shall be broken back a distance of at least 20 mm from the concrete surface. All fittings for metal ties shall be of such design that, upon their removal, the cavities which are left will be of the smallest possible size. Torch cutting of steel formwork hardware at concrete surfaces will not be permitted. All cavities created from ties or associated hardware removal shall be filled with an approved concrete patching material from the Department's Product List in the Vertical/Overhead (OH-V) category and placed in accordance with the manufacturer's published product data sheet.

When plastic sleeves and removable inner rods are used, the plastic sleeve shall be removed for a distance of 100 mm from the face of the concrete except for curbs, barriers and medians where the entire plastic sleeve shall be removed. The cavity shall be filled with an approved non-shrink grout to 75 mm from the concrete surface and cured a minimum 24 hours. The remaining 75 mm of the cavity shall then be filled with an approved concrete patching material. When fibre reinforced polymer rods are used they shall be removed a distance of 75 mm back from the face of the concrete and filled with an approved concrete patching material from the Department's Product List in the Vertical/Overhead (OH-V) category and placed in accordance with the manufacturer's published product data sheet.

#### 4.8.34.10.4 ~~4.10.4~~ Forms Formwork for Unexposed Surfaces

The minimum acceptable ~~forming~~ formwork for unexposed concrete shall have 15 mm plywood supported at 400 mm maximum on centres.

#### 4.8.44.10.5 ~~4.10.5~~ Standard Details

The Contractor shall use the standard details shown on Standard Drawings ~~S-1411 "Standard Concrete Joints", S-1412 "Standard Construction Joints", and S-1443 "Deck 1838, Standard Waterproofing"~~.

~~4.10.6 System For Deck and Abutments - Sheet 1, S-1839, Standard Waterproofing System For Deck Formwork and Abutments - Sheet 2, and S-1840, Standard Waterproofing System For Deck and Abutments - Sheet 3.~~

#### 4.8.54.10.6 Deck Formwork

~~Unless otherwise noted, diaphragms and girders will be designed in accordance with CSA S6-06 Clause 3.16 for construction loads during casting of deck concrete. The loads assumed for such design will be shown on the Drawings. Where construction loads or loading conditions proposed by the Contractor vary from those shown on the Drawings, the Contractor shall be responsible for maintaining all measures required to maintain girder stability and alignment until~~

After girder elevations at the abutments, piers and splice locations have been reviewed and accepted by the Consultant, the Contractor shall survey all girders at locations corresponding with those detailed on the camber diagram and determine girder haunch dimensions required to achieve design grades. The survey data shall be submitted to the Consultant for review and acceptance of the calculated deck thickness, grades, and haunch dimensions a minimum of 3 days prior to the commencement of deck concrete has gained sufficient strength. reinforcing steel placement. If the design haunch dimensions vary more than allowable girder fabrication tolerances, the Contractor may revise grades with the acceptance of the Consultant.

~~The Contractor shall design and install support brackets such that no damage to girder flanges and webs will result.~~ Where required, deck formwork design shall include any additional bracing system to those shown on the Drawings. ~~Care shall be taken in the design and installation of support brackets to avoid damage to girder flanges and webs. Where such brackets bear against girder webs, the girder webs shall be protected by timber or neoprene softeners. No drilling of additional holes or any other modifications including field welding shall be made to the superstructure elements.~~ Effects of concentrated loads on thin webs shall be checked, and where necessary, sufficient means shall be provided to distribute or carry such concentrated loads to the supporting flanges or stiffeners. Where brackets bear against girder webs, the Contractor shall protect the contact surface with timber or neoprene softeners. No drilling of additional holes, or any other modifications including field welding, shall be made to the superstructure elements.

Formwork for decks, curbs, sidewalks and parapets shall be fabricated so that the lines and grades shown on the drawing are achieved, with adjustments made where necessary to compensate for variances in girder dimensions, positioning, alignment and sweep.

Formwork hangers or ties for exposed surfaces of decks, including underside surfaces, shall be removable threaded type. No portion of the hardware associated with deck or deck overhang formwork shall be visible after all formwork has been removed. All cavities resulting from threaded rod removal along the underside of deck overhangs shall be adequately prepared and filled with an approved concrete patching material: from the Department's Product List in the Vertical/Overhead (OH-V) category. Deck overhang patches shall be placed level with adjacent surfaces and be similar in ~~color~~colour and texture. For interior bays, all cavities resulting from threaded rod removal shall be filled with Sikaflex 15LM or an approved equivalent. The caulked surface shall be placed level with adjacent surfaces and be similar in ~~color~~colour.

~~Formwork for decks, curbs, sidewalks, and parapets shall be fabricated so that the lines and grades shown on the Drawings are achieved. Girders will be erected to normally accepted industry standards of tolerance; however, it may be necessary to adjust the formwork to compensate for variances in girder dimensions, positioning, alignment, and sweep.~~

~~After girder elevations at the abutments, piers and splice locations have been reviewed and accepted by the Consultant and prior to commencing deck formwork, the Contractor shall profile all the girders at points corresponding to the camber diagram and determine the girder haunch dimensions required to achieve the specified gradeline. This information shall be provided to the Consultant for review and acceptance prior to commencing any deck formwork.~~

~~In the event that actual girder camber values vary significantly from the estimated values indicated on the drawings, the Consultant may require the Contractor to raise or lower the gradeline accordingly.~~

#### ~~4.94.11~~ **4.11** — Protection of “Weathering” Steel Girders

Where steel girders are fabricated of “weathering” steel, it is essential that the uniformity of rust formation is not adversely affected by the Contractor's work.

The Contractor shall exercise utmost care and provide the necessary protection to prevent marking or staining of the girders. All joints between deck formwork and steel members (including interior girders, and diaphragms) shall be sealed to prevent leakage of cement paste or concrete. ~~Caulking, duct tape, ethafoam, or any other suitable means or material,~~ Polyurethane sealant or approved equivalent materials shall be used to achieve the seal.

~~Should~~ If foreign material ~~spill~~ spills onto the girders despite the protection provided, the Contractor shall clean off, wash, and ~~sandblast~~ lightly abrasive blast the contaminated areas, to the satisfaction of the Consultant. ~~Additionally, should~~

If the exterior ~~face~~ fascia web and flanges of an exterior girder ~~become~~ becomes contaminated with foreign material, stained or marked, the ~~entire Contractor shall clean off, wash and abrasive blast the exterior face of the girder line shall be lightly sandblasted and "weathered" so~~ fascia web and flanges and weather the surfaces such that uniformity of girder ~~color, in the opinion of the Consultant, colour~~ is achieved.

"Weathering" shall be achieved by repeatedly fogging the exterior girder faces with clean water and ~~then,~~ allowing ~~them~~ to dry. Fogging ~~should~~ shall leave ~~the girders~~ girder surfaces wet but not "running wet", and ~~should~~ be repeated when the girders are completely dry until a finish acceptable to the Department is achieved.

The cost of sealing and stain -prevention shall be included in the unit price bid for the deck concrete; no separate or additional payment will be made for the cost of protecting the girders, nor for any cleaning, sandblasting or "weathering" made necessary by the Contractor's work.

#### ~~4.104.12~~ 4.12—Protection of Concrete Work and Bridge ~~Components~~ Elements from Staining

The Contractor shall take precautions to protect all concrete work and bridge ~~components~~ elements from staining. If staining occurs it shall be removed to the full satisfaction of the Consultant. Stained concrete surfaces that have received a Class 3 finish shall have the entire surface face of the component sandblasted and the Class 3 finish reapplied. Stained concrete surfaces that have received a Class 2 finish shall have the entire surface face of the component refinished. There shall be no trace of staining after the specified concrete finishing is completed.

#### ~~4.114.13~~ 4.13—Removal of Falsework, Forms and Housing

Forms and their supports shall not be removed without the review and acceptance of the Consultant. In determining the time for the removal of falsework, forms and housing, and the discontinuance of heating, consideration shall be given to the location and character of the structure, the weather and other conditions influencing the curing of the concrete, and the materials used in the mix.

The following guide for removal of forms and supports may be used if the temperature of the concrete is maintained at no less than 15°C and review and acceptance of the Consultant is received:

<u>Portion of Work</u>	<u>Age or Minimum Strength</u>
Arches and girders	14 days or 80% of 28 -day strength
Pier caps and beams	5 days or 50% of 28 -day strength
Columns	1 to 3 days
Decks & Slabs	5 days or 50% of 28 -day strength
Vertical faces less than or equal to 3 m in height	12 to 24 hours
Vertical faces over 3 m in height	2 days

Supports and forms may be removed from arches, girders, deck, pier caps and beams earlier than the minimum curing periods specified above, with the Consultant's acceptance. In seeking acceptance the Contractor shall, at his own expense, furnish evidence satisfactory to the Department and Consultant that the strength of the concrete in place has attained the above noted percentage of the specified 28 -day strength before removal.

Supports shall be removed in such a manner as to permit the concrete to uniformly and gradually take the stresses due to its own weight.

All formwork ~~must~~shall be removed from the completed structure. ~~For certain special situations, formwork may remain in place, when the Contractor's formal request is approved by the Consultant and Department.~~

#### ~~4.12.14~~ 4.14 — Handling and Placing Concrete

##### ~~4.12.14.14.1~~ 4.14.1 General

The Contractor shall ~~give~~provide the Consultant with a minimum of two days advance notice of a concrete pour date or a change to a pour date.

The method of concrete placement shall have a consistent, minimal impact on the concrete properties. All equipment proposed for use in mixing, conveying, placing and compacting the concrete shall be reviewed and accepted by the Consultant prior to its use. All the necessary equipment for any particular pour shall be on site and proven to be in working condition before the pour commences, with backup equipment on site as determined by the Consultant. The equipment shall be well maintained, suitable for the intended purpose and adequate in capacity for the work.

In preparation for the placing of concrete, all sawdust, wood chips and other construction debris and ~~extraneous matter~~foreign materials shall be removed from the interior of forms. Struts, spreaders, stays, and braces, serving temporarily to secure the forms in correct shape and alignment, pending the placing of concrete at their locations, shall be removed when the concrete placing has reached an elevation rendering their service unnecessary. These temporary members shall be entirely removed from the forms and not buried in the concrete.



Concrete shall be placed so as to avoid segregation of the materials and the displacement of the reinforcement. ~~When placing operations consist of free dropping concrete more than 1 m, it shall be deposited by concrete pump, metal or plastic chutes or other means acceptable to the Consultant.~~ When depositing concrete by mixer truck chute, concrete pump or crane and bucket, the free fall of the concrete shall not exceed 1 metre. Concrete placement in elements containing multiple layers reinforcing steel shall be completed such that the concrete is not deposited on upper layers of reinforcing steel.

Concrete for the structure shall be deposited in the forms in the order indicated on the Drawings, and each portion placed between construction joints shall be placed in one continuous operation. No other order of pouring shall be done unless otherwise accepted by the Consultant.

Concrete placing operations shall not work off, or transport concrete directly over concrete previously placed without the acceptance of the Consultant.

#### ~~4.12.24.14.2~~ 4.14.2 Consolidation

Concrete, during and immediately after depositing, shall be thoroughly consolidated. The consolidation shall be done by mechanical vibration, and subject to the following provisions:

- ~~————~~ The vibration shall be internal unless special authorization of other methods is given by the Consultant, or the Consultant requests the use of other method(s);
- ~~————~~ Vibrators shall be of a type and design acceptable to the Consultant. They shall be capable of transmitting vibrations to the concrete at frequencies of not less than 4500 impulses per minute;
- ~~————~~ The intensity of vibration shall be such as to visibly affect a mass of concrete of 25 mm slump over a radius of at least 0.5 m;
- ~~————~~ The Contractor shall provide a sufficient number of vibrators to properly compact each batch, immediately after it is placed in the forms;
- ~~————~~ Vibrator operators shall be suitably instructed in the use of vibrators, and the importance of adequate and thorough consolidation of the concrete;
- ~~————~~ Vibrators shall be manipulated so as to thoroughly work the concrete around the reinforcement and imbedded fixtures and into the corners and angles of the forms. Vibration shall be applied at the point of deposit and in the area of freshly deposited concrete. The vibrators shall be inserted vertically and withdrawn out of the concrete slowly. The vibration shall be of sufficient duration and intensity to thoroughly compact the concrete, but shall not be continued so as to cause segregation. ~~Vibration shall not be continued at any point to the extent that localized areas of grout are formed.~~ Application of vibrators shall be at points uniformly spaced and not farther apart than the radius over which the vibration is visibly effective;
- ~~————~~ Vibration shall not be applied directly or through the reinforcement of sections or layers of concrete which have hardened to the degree that the concrete ceases to be plastic under vibration. ~~It shall not be used to make concrete flow in the forms over distances so great as to cause segregation, and vibrators shall not be used to transport concrete in the forms;~~

- ~~————Vibrators shall not be used to transport concrete within forms or made to flow over distances resulting in segregation;~~ Vibration shall be supplemented by spading as is necessary to ensure smooth and dense concrete along form surfaces and in corners and locations impossible to reach with the vibrators; ~~and~~
- ~~————Once vibrated the Contractor shall avoid disturbing not disturb the concrete and shall not, step into the concrete~~ or add additional concrete after vibration.

#### 4.12.34.14.3 ~~4.14.3~~ Additional Requirements

When concrete placing is discontinued, for whatever reason, all accumulations of ~~mortar splashed concrete or concrete paste deposited~~ on ~~the projecting~~ reinforcing steel and the form surfaces shall be removed. ~~If the accumulations are not~~ Accumulations shall be removed prior to the concrete ~~or concrete paste~~ becoming set; ~~Care shall be exercised not to injure or break taken during cleaning such that the concrete-~~ to steel bond ~~at and near the surface of the concrete, while cleaning the reinforcing steels~~ is not adversely affected.

Concrete shall be placed while fresh and before it has taken its initial set. ~~Re-tempering of~~ Partially hardened concrete ~~with additional water will~~ shall not be ~~permitted~~ tempered. Concrete that does not reach its final position in the forms within the time limits specified shall not be used.

After initial set of the concrete, the forms shall not be jarred or any strain placed on the ends of projecting reinforcing bars.

Concrete which would be adversely affected by the presence of freestanding water shall be protected to prevent its occurrence, and the Contractor shall take whatever steps may be necessary to prevent free water build -up in the event of unexpected rainfall or similar occurrences for the first 24 hours.

Water used to keep equipment clean during the pour, or to clean equipment at the end of the pour, shall be discharged ~~clear of~~ in a designated area acceptable to the structure and water crossing Consultant.

#### 4.12.44.14.4 ~~4.14.4~~ Pumping

The operation of the pump shall produce a continuous flow of concrete without air pockets. The equipment shall be so arranged ~~that the impact on the plastic air content of the concrete shall not vary by  $\pm 0.5\%$  and such~~ that the freshly placed concrete is not damaged by ~~any form of~~ pump vibration. When pumping is ~~completed~~ complete, the concrete remaining in the pipeline, if it is to be used, shall be ejected in such a manner that there will be no contamination or segregation of the concrete ~~or separation of the ingredients~~.

**4.134.15 4.15—Placing Pile Concrete****4.15.1 General**

~~The Contractor shall make all attempts necessary to obtain a dry pile hole prior to placing pile concrete. If in the opinion of the Consultant and the Department that all attempts to achieve a dry pile hole have been taken and proven unsuccessful, placement of pile concrete under water will be required.~~

**4.15.2 Concrete Placed in the Dry**

~~Pile concrete shall be placed by means of a hopper equipped with a centre pipe drop tube. The pipe drop tube shall be a minimum of 200 mm in diameter and 2 m long. Concrete may be placed free fall, providing the fall is vertically down the centre of the casing or drilled hole and there are no transverse ties or spacers. Pile concrete shall have a slump range of  $130 \pm 30$  mm at time of discharge. Concrete in the upper 3 m of the piles shall be consolidated by the use of an acceptable concrete vibrator.~~

**4.15.3 Concrete Placed under Water**

~~Placement of pile concrete under water shall be in accordance with Section 4.22 of this Specification and also with the following additional requirements:~~

**Crosshole Sonic Logging**

~~In order to test for voids or other abnormalities in the concrete, all drilled pile shafts cast under water shall be equipped with PVC or steel access tubes to permit inspection by Crosshole Sonic Logging (CSL). The Contractor shall submit the proposed method for the Consultant's review two weeks before beginning drilled pile work. The Contractor shall supply and install four 50 mm inside diameter tubes in each drilled pile with a diameter of 1.5 m or less and six tubes in each pile with a diameter of greater than 1.5 m.~~

~~Tubes supplied shall be round, have a regular internal diameter that is free from defects, obstructions and joints. Tubes shall be watertight, free from corrosion and have clean internal and external faces to ensure a good bond between the concrete and the tubes. Tubes may be extended with watertight mechanical couplings and all coupling locations shall be recorded. Tubes shall be installed by the Contractor in a manner that the CSL probes pass through the entire length of the tube without binding.~~

~~The Contractor shall fit the tubes with a watertight shoe on the bottom and a removable cap on the top. Tubes shall be secured to the interior of the reinforcement cage a minimum of every 1.2 m along the length of the pile. Tubes shall be installed uniformly and equidistantly around the circumference of the pile such that each tube is spaced parallel for the full length. Tubes shall extend to within 150 mm of the drilled shaft bottoms, and shall extend a minimum of 600 mm above the drilled shaft tops or where they are accessible. Tubes shall be capped to prevent debris from entering the access tubes.~~

~~The Contractor shall ensure that CSL tubes are not damaged during the installation of the reinforcement cage. If testing equipment does not pass through the entire length of the CSL tube, a 50 mm diameter core hole shall be drilled. Special care must be taken to avoid tube debonding between the concrete and the tubes. If tube debonding occurs, the Contractor shall core drill a 50 mm diameter hole to the depth of debonding for each debonded tube.~~

~~The Contractor shall make CSL measurements at depth intervals of 65 mm from the bottom of the tubes to the top of each pile. Upon completion of testing and acceptance of the pile concrete, the tubes shall be filled with an approved grout mix.~~

### **Qualification**

~~The testing agency hired by the Contractor shall have a minimum of 3 years' experience in CSL testing and have a Professional Engineer registered in the Province of Alberta to assume responsibility for all testing at site and interpretation of results. The Contractor shall provide written evidence of completion of all CSL tests by the testing agency. The Contractor's submission shall also include personnel qualifications and descriptions of testing equipment.~~

### **CSL Results**

~~The Contractor shall submit two original copies of the CSL report to the Consultant within 5 working days of completion of CSL testing. The report shall be signed and sealed by the CSL engineer and include test summaries, results, analyses, and an opinion of the pile concrete's suitability for intended use. Test summaries shall be in accordance with the criteria listed below:~~

### **Concrete Condition Rating Criteria**

Rating	Velocity Reduction *	CSL Results
Good (G)	$\leq 10\%$	Good quality concrete
Questionable (Q)	$>10\% \ \& \ <20\%$	Minor contamination or intrusion Questionable quality concrete
Peer/Defect (P/D)	$\geq 20\%$	Defects exists, possible water/slurry contamination, soil intrusion and/or poor quality concrete
No Signal (NS)	No Signal Received	Soil intrusion or other severe defect absorbed the signal

\* From highest measured signal velocity in the comparable zone

~~CSL test results with ratings other than "G" will be considered unacceptable and will result in rejection of the pile. In the event that the Contractor elects to carry out further investigation to prove the acceptability of the pile, the boundaries of any defective/unconsolidated zones shall be delineated by means of cross-hole tomography and supplemented with additional testing. Additional testing may include 3D tomographic imaging, single-hole sonic testing, sonic echo or impact response tests, or concrete coring.~~

~~The Consultant in consultation with the CSL engineer will determine the depth, location, diameter and number of core holes when concrete coring is required. If the Consultant is concerned about concrete strength or requires the use of a borehole camera for inspection, large diameter cores may be required. Minimum of two cores would be required to intercept the suspected defect zones.~~

~~The pile will not be considered acceptable until the Consultant and the Department has reviewed and accepted the report and determined if further remedial action is required. When the Consultant and Department determine a drilled pile is unacceptable, the Contractor shall submit a remedial action proposal with supporting calculations to the Department and the Consultant for review and acceptance. The remedial action shall be designed by the Contractor and signed and sealed by a Professional Engineer registered in the Province of Alberta. No compensation will be made for remedial work or losses or damages due to remedial work of drilled piles found defective or not in accordance with the Specifications.~~

#### ~~4.144.1~~ **Measurement and Payment**

~~CSL will be considered incidental to the Work and no additional or separate payment will be made for procurement, conducting the CSL testing, reporting of results and incidentals necessary to complete the work including any other test required to determine the acceptability of the drilled pile.~~

~~4.16~~ Pile concrete shall be placed in accordance with Section 3, Foundation Piles.

#### ~~4.154.16~~ **Placing HPC Concrete and HPC Concrete with Steel Fibres**

##### General

##### ~~4.16.1~~ **General**

##### ~~4.16.1~~ Concrete placing will

~~HPC concrete and HPC concrete with steel fibres shall not be permitted placed when the air temperature is below +5°C or 5°C, or is expected to fall below 5°C during the curing period, or when the air temperature is above 25°C, or in the event of rain or excessive wind or dust, or when there are other conditions judged detrimental to the concrete as determined by the Consultant to be harmful to the concrete.~~

HPC concrete and HPC concrete with steel fibres shall be placed between the hours of 6:00 pm and 10:00 am of the following day, unless reviewed and accepted by the Department and Consultant. Lighting is required for night pours and shall be reviewed and accepted by the Consultant. HPC concrete and HPC concrete with steel fibres shall not be placed when the evaporation rate exceeds 0.5 kg/m<sup>2</sup>/hr. The evaporation rate shall be determined using Figure D.1, of CSA A23.1 – Annex D. The rate of evaporation shall be recorded as concrete placing operations progress and the Contractor shall make all necessary adjustments to ensure the evaporation rate does not exceed the specified limit.

~~Lighting is required for night pours and shall be reviewed and accepted by the Consultant.~~ The temperature of the concrete during discharge shall be between 10°C and 20°C unless reviewed and accepted by the Consultant. The temperature of the mix shall be maintained below the 20°C maximum temperature by the inclusion of ice to the mix which shall not alter the design water-cementing materials ratio. Prior to placing concrete, substrate surfaces shall be brought to a saturated surface dry condition with clean water meeting the requirements of Section 4.2. Subsection 4.2.3, Water. Substrate surfaces shall be free of standing water.

A construction milestone meeting shall be scheduled by the Contractor for deck and deck overlay concrete. The Contractor shall submit a deck or deck overlay concrete procedure to the Consultant for review and acceptance a minimum of 2 weeks prior to the scheduled construction milestone meeting. The deck pour procedure shall include, but not be limited to, documentation outlining compliance with specification requirements. The Contractor's project manager ~~and~~, field superintendent, and concrete finishing supervisor shall attend a ~~pre~~-construction milestone meeting at a location determined by the Consultant, a minimum of one week prior to commencement of ~~any site work~~concrete placement.

All deck concrete and deck overlay concrete shall be consolidated in accordance with Section 4.14.2 Subsection 4.14.2, Consolidation, even when vibratory drum type placing/finishing machines are used.

#### Placing/Finishing Machines

~~For all deck concrete and deck overlay concrete~~All reinforcing steel projecting from deck surfaces (barriers, curbs, medians, and adjacent deck pour sequence stages) shall be covered during deck concrete placement, consolidation, screeding shall be by, and testing operations such that it is not contaminated with concrete or concrete paste.

Deck and deck overlay concrete shall be screeded using one of the following concrete placing/finishing machines as follows or an equivalent acceptable equivalentsto the Department:

- ~~Terex Bidwell Models RF200, 364,; 2450, 3600 and, 4800;~~
- ~~Gomaco Models; C450 and, C750; or~~
- Allen Models: 4836 B, 6036 B, 6048 B.

The Contractor shall provide two work bridges, separate from the placing/finishing machine, of adequate length to completely span the width of the pour. The work bridges shall facilitate the operations of concrete finishing and ~~placing~~placement of filter fabric and shall also be made available to the Consultant for straight ~~-edge~~ checking. The work bridges shall be supported ~~essentially~~ parallel to the concrete surface, between 250 mm and 600 mm above the concrete surface, and shall ~~be at least 800 mm~~provide an unobstructed working surface that is wide enough to permit diverse uses concurrently, and ~~be~~ rigid enough that dynamic deflections are ~~insignificant-negligible, as determined by the Consultant. Work bridges shall include specialized work platforms to facilitate concrete finishing in front of curbs, barriers or medians.~~

#### 4.15.14.16.2 ~~4.16.2~~ Screed Guide Rails and Supports

~~Acceptable~~ Steel screed guide rails and supports shall be installed to suit the profile of the required surface and to ensure a smooth and continuous surface from end to end of the bridge. Guide rails ~~must be located outside of the finished surface of the pour for overlay and deck concrete, unless specified otherwise in the Special Provisions. Rails shall extend beyond the end of the bridge to accommodate finishing of and the entire concrete deck surface shall be screeded~~ with the deck ~~placing~~/finishing machine. ~~All~~ Guide rails and guide rail supports shall ~~not be removed with minimal disturbance to the~~located within any concrete pour.

#### 4.15.24.16.3 ~~4.16.3~~ Dry-Run

The finishing machine shall be set-up to match the skew angle of the bridge, when the skew angle exceeds 15°. For skewed bridge structures on vertical curves this requirement may be altered to suit actual site conditions.

The deck finishing machine ~~and guide rails shall be adjusted so that the height of the screed will finish the concrete to the design gradeline and crown. To confirm the adjustment of the machine and guiderails, the screed shall be dry-run prior to the pour and clearance measurements taken to determine deck thickness and reinforcing steel cover at each of the girder points~~locations corresponding ~~to with those detailed on the camber diagram, and provided to the Consultant for review and acceptance. Re-setting of the~~ Adjustment of the deck finishing machine and/or screed guide rails shall be completed such that the design grades, deck designed thickness and reinforcing steel concrete cover are achieved. The deck finishing machine or guide rails shall be done as necessary, to obtain an acceptable dry-run. Adjustments to the machine or screed rails will not be permittedadjusted after an acceptable the dry-run has been completed and the results have been reviewed and accepted by the Consultant. If the finishing machine is adjusted for any reason after acceptance, the dry-run, including all checks, shall be repeated.

Where screed rails are supported on cantilevered formwork that may deflect under the weight of the fresh concrete and the deck finishing machine, the Contractor shall pre-load a test section of the cantilevered formwork on each side of the bridge to determine deflections occurring during concrete placement. The formwork, machine and/or screed rails shall be adjusted to compensate for the expected formwork deflection.

~~4.15.34.16.4~~ ~~4.16.4~~ Screeding Concrete

Concrete shall be placed as close as practical ahead of the finishing machine, and at no time more than 6 m in front of the trailing end of the finishing machine's roller.

The screed shall be moved slowly and at a uniform rate. ~~In general,~~ The direction of ~~pouring~~ ~~should~~ ~~concrete placement shall~~ be from the low end of the bridge to the high end. A roll of concrete shall be maintained along the entire front of the screed at all times to ensure the filling and consolidation of the concrete surface. The contractor shall also ensure that the required concrete thickness is being placed by continually probing the concrete behind the finishing machine.

Screeding shall be completed in no more than two passes. ~~The screeded surface shall not be walked on or otherwise damaged and may require finishing machines or work bridges to be equipped or fitted with specialized work platforms to facilitate concrete finishing in front of curbs, barriers or medians.~~

~~4.16.5~~ Screeded surfaces shall not be walked on or otherwise damaged.

~~4.15.44.16.5~~ Bull Floating/Surface Texturing

The concrete surface produced behind the finishing machine shall be manually bull floated with a magnesium bull float to ensure that the surface is free from open texturing, plucked aggregate and local projections or depressions. Bull floating and surface texturing shall follow as close as practically possible behind the screed. ~~It is imperative that competent workers be employed to carryout bull floating and surface texturing~~ Concrete finishing shall be completed by an individual who has completed the ACI Concrete Flatwork Finisher Certification Program or under the direct supervision of a certified journeyman concrete finisher.

Evaporation reducer or water shall not be finished into the concrete at any time during finishing operations.

The Contractor shall check the concrete surface with a 3 m long expanded polystyrene straight edge immediately after final bull floating and before texturing or application of evaporation reducer to ensure the required surface tolerances are met. Concrete surfaces that do not meet the surface tolerances described in ~~4.16.6~~ Subsection 4.16.6, Surface Defects and Tolerances shall be corrected while the concrete is still plastic and before curing procedures are implemented.

~~4.15.54.16.6~~ ~~4.16.6~~ Surface Defects and Tolerances

The finished surface of the concrete shall conform to the design gradeline ~~profiles as~~ indicated on the Drawings ~~and/or as determined on site. Any.~~ The details of any proposed gradeline profile modifications shall be reviewed and accepted by submitted to the Consultant for review and acceptance. For any required corrective work the Contractor shall submit a repair procedure for review and acceptance by the Department and Consultant one week prior to commencement of the work.



The surface shall be free from open texturing, plucked aggregate and local projections.

Except across the crown, the surface shall be such that when checked with a 3 m long straight edge placed anywhere in any direction on the surface, there shall not be any gap greater than 3 mm between the bottom of the straight edge and the surface of the deck concrete. Areas with surface defects or do not meet the required surface tolerances will be clearly marked out by the Consultant and the Contractor shall at his expense:

~~Areas that do not meet the required surface accuracy shall be clearly marked out and the Contractor shall, at his own expense:~~

- ~~• (a) — Remove and replace areas where the deviation exceeds 10 mm from the correct surface. As a minimum, the Contractor's repair procedure shall include saw cuts 25 mm deep in neat perpendicular lines and concrete removed to a depth of 35 mm below the top mat of reinforcing steel. Repair areas shall be roughened to remove all loose material and laitance. Exposed reinforcing steel shall be cleaned and repaired to its original condition. Repair areas shall be saturated with water for a period of 24 hours prior to concrete placement. Repair areas shall be free of standing water and surface dry immediately prior to placing class HPC concrete. Curing shall be in accordance with the requirements for class HPC concrete;~~
- Grind down any areas higher than 3 mm but not higher than 10 mm above the correct surface; or
- ~~(b) — Correct any areas lower than 3 mm but not lower than 10 mm below the correct surface, by grinding down the adjacent high areas.~~

~~(c) When the deviation exceeds 10 mm from the correct surface, the deck slab shall be removed and replaced in accordance with Section 20.3.2 "Partial Depth Repair", resulting in a product that is in no way inferior to the adjacent undisturbed slab. The perimeter of the joint created by the repair area shall be waterproofed in accordance with the details on S-1443. Replaced areas shall be at the Contractor's expense.~~

~~Grinding shall be carried out by an approved machine, of a type and capacity suitable for the total area of grinding involved, until the surface meets the specified requirements.~~

~~All corrective work will require the Contractor to submit a proposal for review and acceptance by the Department and Consultant, prior to commencement of any work.~~

Concrete surfaces that are damaged in any way by construction operations, or show signs of distress or scaling shall be repaired or replaced by the Contractor at his ~~own~~ expense.

#### ~~4.16.17~~ **4.17 — Placing Approach Slab and Roof Slab Concrete**

After properly placing and consolidating the concrete, it shall be struck off and screeded to conform to the required cross -section and grade. Concrete placing shall be carried out in a manner such that the newly deposited concrete is continually placed against fresh concrete across the entire face of the pour and the formation of cold joints is avoided. A slight excess of concrete shall be kept in front of the screed at all times.

The screeded concrete surface shall then be manually bull floated longitudinally, transversely or in both directions as necessary to ensure that the surface is free from open texturing, plucked aggregates, and local projections or depressions. Evaporation reducer or water shall not be added to the concrete at any time during finishing operations.

The surface shall be such that it does not vary by more than 3 mm from the required lines, under a 3 m straightedge placed anywhere, in any direction except across the crown.

#### ~~4.174.18~~ **4.18—Concreting Shear Keys and Diaphragms**

Form work for shear keys and diaphragms shall be designed to accommodate variations in girder dimensions, positioning, alignment, camber and sweep. Girder keyways and diaphragms shall be brought to a saturated surface dry condition prior to concrete placement. Saturation with water shall not be less than 30 minutes prior to blowing free of standing water. Concrete placed in the keyways shall be adequately consolidated and trowelled smooth and level with the top surfaces of the girders. Immediately after trowelling, two layers of clean Nilex 4504 white ~~colored~~coloured filter fabric or an approved equivalent shall be placed on the shear keys and kept continuously wet for 72 hours.

#### ~~4.184.19~~ **4.19—Concrete Slope Protection**

A minimum of one week prior to commencing concrete slope protection Work, the Contractor shall submit a detailed layout and forming plan to the Consultant for review and acceptance. The detailed layout and forming plan shall comply with Standard Drawing S-1409, Standard Concrete Slope Protection and these specifications.

All thickness measurements indicated herein are perpendicular to the top of concrete slope surface.

The slopes to be covered with concrete slope protection shall be trimmed and dressed by the Contractor to within 150 mm of the lines and grades shown on the Drawings. The Contractor shall supply and place Des 2 Class 25 crushed aggregate material to ~~a minimum thickness of 100 mm~~the thicknesses shown on the Drawing over the trimmed slopes. Crushed aggregate material shall conform to the requirements of ~~Section 2.2.2 Gravel Material and Crushed Aggregate Material, Backfill.~~

Where slopes have been constructed by others, and excavation exceeding 250 mm or fill exceeding 150 mm is required due to discrepancies in position of the original surface, excavation beyond the 250 mm tolerance limit and/or fill beyond the 150 mm tolerance limit will be considered to be Extra Work. Depending upon the circumstances of the particular project the Department and the Consultant may vary the specified concrete grades so as to minimize the amount of remedial trimming required. Excavation up to 250 mm and/or fill up to 150 mm will be considered as included in the bid price.

Concrete for slope protection shall be Class C.

~~Sheet~~ Reinforcing steel shall plain reinforcing ~~mesh shall be placed steel and~~ in accordance with Section 5, Reinforcing Steel. The Contractor's method of securing and maintaining the ~~wire mesh reinforcing~~ in its proper location shall be ~~reviewed submitted~~ and ~~accepted by to~~ the Consultant for review and acceptance a minimum of 1 week prior to commencement of the Work.

The concrete shall be placed in either horizontal or vertical courses, with one course being allowed to cure for at least 12 hours before the adjoining course is placed. Formwork shall be provided below and above the ~~wire mesh reinforcing~~ to ensure proper slab thickness, correct positioning ~~of the mesh~~, and the formation of proper cold joints between courses. Vertical or horizontal joints shall be formed or grooved 50 mm to the depth of the reinforcing ~~mesh~~. All joints shall be finished with suitable edging and grooving tools and left unfilled. The concrete surfaces shall be given a Class 5 finish prior to edging and grooving. Finishing work shall be carried out by competent and experienced personnel only.

Backfill ~~at along~~ the ~~tee, top or edges sides of concrete slope protection~~ shall be non-granular, conforming to the requirements of Section ~~2.2.1 Compacted Non-granular Material, Backfill~~ and shall not be placed until the completed concrete slope protection ~~work~~ has been reviewed and accepted by the Consultant.

#### ~~4.19.4.20~~ ~~4.20~~ — Construction Joints

##### ~~4.19.14.20.1~~ ~~4.20.1~~ General

Construction joints shall be made only where indicated on the Drawings ~~or shown in the pouring schedule unless otherwise unless~~ reviewed and accepted by the Consultant.

If not detailed on the Drawings, or in the case of emergency, construction joints shall be installed in accordance with Standard Drawings S1412S-1412, Standard Cast-In-Place Concrete Construction Joints or as determined by the Consultant. Shear keys or inclined reinforcement shall be used where necessary to transmit shear, or to bond the two sections together. Construction joints shall be located to allow a minimum of 5060 mm concrete cover on reinforcing steel running parallel to the joint.

##### ~~4.19.24.20.2~~ ~~4.20.2~~ Bonding

Before depositing new concrete on or against concrete which has hardened, the forms shall be retightened and the surface of the hardened concrete shall be thoroughly cleaned ~~and saturated with water, with all free standing water removed. to remove laitance or other foreign materials.~~ The hardened concrete surface shall then be blown clean with compressed air and saturated with water meeting the requirements of Subsection 4.2.3, Water. Immediately prior to placement of new concrete against hardened concrete the saturated surface shall be blown clean with compressed air such that no standing water is present.

The placing of concrete shall be carried out continuously from joint to joint. The face edges of all joints which are exposed to view shall be carefully finished true to line and elevation.

**4.204.21 4.21—Concreting in Cold Weather**

~~When~~ In addition to the ambient requirements of Subsection 4.23, Curing Concrete, when the air temperature is, or is expected to be below ~~5°C~~ °C as forecasted by the closest Environment Canada Meteorological Station during the placing and curing period, or when determined by the Consultant, a cold weather concreting plan shall be implemented. The Contractor shall submit details of his proposed cold weather concreting plan to the Consultant for review and acceptance a minimum of two weeks prior to any concrete placement. The Contractor's concreting plan shall incorporate the following requirements:

- (1) ~~(1)~~—All aggregate and mixing water shall be heated to a temperature of at least 20°C but not more than 65°C. The aggregates may be heated by either dry heat or steam; in the latter case the quantity of mixing water may need to be reduced. The temperature of the concrete shall be in accordance with ~~Section 4.4.3~~ Subsection 4.4.3, Concrete Temperature at Discharge, at the time of placing in the forms. In the case of mass pours, the Consultant may alter the temperature requirements to suit.
- (2) ~~(2)~~—The Contractor shall enclose the structure in such a way that the concrete and air within the enclosure can be kept at or above 15°C for a protection period of 7 days after placing the concrete. Enclosures shall be constructed with a minimum 300 mm clearance between the enclosure and the concrete.

For class HPC or HPC with steel fibres the 7 day protection period shall be increased to ~~24~~ 17 days ~~;~~ (14 days wet curing and 3 days of air drying). The enclosure for class HPC or HPC with steel fibres shall be constructed large enough to comfortably accommodate ~~the menworkers~~ and equipment necessary to place, finish and cure the concrete. The underside of ~~the deck~~ bridge decks shall be suitably ~~protected~~ enclosed and heated.

The relative humidity within the enclosure shall be maintained at not less than 85%. Heaters must be kept well clear of the formwork housing. Adequate ventilation is required to provide air for combustion, and to prevent the accumulation of carbon dioxide. The use of salamanders, coke stoves, oil or gas burners and similar spot heaters which have an open flame and intense local heat is prohibited without the Consultant's specific acceptance.

The system of heating, and positioning of steam outlets, heaters, and fans, shall be designed to give the most uniform distribution of heat possible.

- (3) ~~(3)~~—Before placing concrete, adequate pre ~~-~~heat shall be provided to raise the temperature of formwork, reinforcing steel, previously ~~-~~placed concrete, substrate surfaces, and/or soil to between 10°C and 20°C.

- (4) ~~(4)~~—~~When reviewed and accepted by the Consultant,~~ fully insulated formwork may be ~~proposed as~~considered an alternative to providing ~~further~~ heat during the curing period. ~~Such—The Contractor shall design and insulate the~~ formwork ~~shall be designed and insulated with approved materials so~~such that the initial heat of the mix, and the heat generated during ~~the hydration of the cement, is retained to provide~~processes will maintain the specified curing conditions throughout the curing period. If the insulated formwork fails to maintain the specified conditions, the Contractor shall immediately implement measures to restore them.
- (5) ~~(5)~~—Concrete curing shall be in accordance with the requirements of Subsection 4.23.4.23, Curing Concrete.
- (6) ~~(6)~~—The adequacy of protection shall be monitored and recorded a minimum of every ~~4 hrs~~ hours for the first 72 ~~hrs~~ hours and every 8 ~~hrs~~ hours for the remainder of the curing period, including measurement of internal and surface concrete temperatures. The protective measures shall be modified as necessary to maintain the specified conditions.
- (7) ~~(7)~~—Protection and heating, ~~where~~when used, shall be withdrawn in such a manner so as not to induce thermal shock stresses in the concrete. The temperature of the concrete shall be gradually reduced at a rate not exceeding 10 °C per day to that of the surrounding air. To achieve this, in an enclosure, the heat shall be slowly reduced. The temperature differential between the core of the element and the surface of the element shall not exceed 20 °C. In addition the temperature differential between the surface of the element and the ambient air shall not exceed 15 °C. Ambient air temperature is defined as the temperature at mid-height and 300 mm from the surface of the element. The Contractor shall measure the temperature of internal concrete, surface of the concrete and ambient air temperatures a minimum of every 4 ~~hrs~~ hours, and shall make adjustments as necessary to keep the rate of cooling within the specified parameters.

The Contractor shall demonstrate to the satisfaction of the Consultant that the requirements of the cold weather concreting plan are met.

#### 4.214.22 ~~4.22~~—Depositing~~Placing~~ Concrete under Water

Concrete shall not be deposited under water without the review and acceptance of the Consultant ~~and~~. Concrete placed under ~~his immediate supervision~~water shall be completed in the presence of the Consultant. Concrete to be deposited ~~in~~under water shall be of the specified class, with the mix design modified to provide 170 mm ± 30 mm slump without segregation and a 15% increase in cementing materials above the initial mix design quantity. Anti-washout admixtures incorporating viscosity modifiers may be used in the mix design. The modified concrete mix design for placement under water shall be submitted by the Contractor to the Consultant for review and acceptance ~~by the Consultant~~ in accordance with Section 4.4.4. Subsection 4.4.4, Concrete Mix Design Submission Requirements. The concrete temperature at discharge shall be between 10°C and 25°C.

Concrete shall not be placed in water which is below 4°C or flowing at the point of discharge.

Formwork underwater shall be watertight.

To prevent segregation, concrete shall be ~~carefully~~ placed in a compact mass, in its final position, by means of a concrete pump. ~~When specifically line and/or a tremie system reviewed and accepted by the Consultant, a properly designed and operated tremie may be used. The concrete shall not be disturbed after being deposited. Still water shall be maintained at the point of deposit. The use of non-rigid lines will not be permitted.~~

~~At a minimum a tremie system shall consist of a concrete pump line and any formwork underwater shall be watertight/or a hopper connected to a rigid tube. If constructed in sections, the rigid tube shall have flanged couplings fitted with gaskets.~~

The discharge end of the concrete pump line ~~and/or tremie system~~ shall be lowered to the bottom of the form or pile hole. ~~Pumping shall then proceed with the end of the discharge line being continually buried no less than 500 mm below the surface of fresh concrete at all times, to maintain a seal until the form or hole is completely filled with fresh uncontaminated concrete.~~

~~A tremie, when reviewed and accepted by the Consultant, shall consist of a rigid tube having a diameter between 200 mm and 300 mm, and if constructed in sections it shall have flanged couplings fitted with gaskets. The discharge end shall be temporarily closed at the start of the Work to prevent water from entering the tube. The tremie tube shall be kept full to the bottom of the hopper, and line. Water shall be kept out of the line at all times. When a batch is dumped into the hopper, The flow of concrete shall be induced by slightly raising the discharge end, always of the line while keeping it in a minimum of 1 m below the top of the deposited concrete. The flowplacement of concrete shall be continuous until the Work is completed. Sufficient tremies shall be used to place the concrete under water such that it is not necessary to move any of the tremies from one portion of the pour to another. The use of non-rigid tremie tubes will not be permitted.~~

~~Concrete shall not be placed in water which is below 4°C.~~

The surface of the concrete shall be kept as ~~nearly~~ horizontal as is practicable at all times. ~~The discharge end of the tremie shall be kept buried at least 500 mm in previously placed concrete.~~

Dewatering will not be permitted while concrete placement is ~~being placed in progress~~. Dewatering may proceed when the concrete ~~seal~~ has gained sufficient strength such that ~~dewatering is not harmful~~damage to the ~~performance of the~~ concrete. ~~will not occur.~~

The Contractor shall remove all laitance or other unsatisfactory material from ~~the~~ exposed concrete ~~surface as determined by the Consultant~~ surfaces by scraping, chipping or other acceptable means acceptable to the Consultant. The prepared concrete surfaces shall be reviewed and accepted by the Consultant prior to next sequence of the Work.

#### ~~4.22.4.23~~ 4.23 — Curing Concrete

##### ~~4.22.14.23.1~~ 4.23.1 — General

Freshly deposited concrete shall be protected from freezing, abnormally high temperatures or temperature differentials, premature drying, water damage and moisture loss for the curing period.

All concrete surfaces consisting of Class C or D concrete shall be wet cured. The Contractor shall cover the concrete surface(s) with two layers of clean Nilex 4504 white ~~colored~~coloured filter fabric or an approved equivalent as soon as the surface will not be marred by so doing. The filter fabric shall be kept continuously wet for 72 hours. Where the formwork is left in place for 72 hours or more, no additional curing will be required. Curing compounds shall not be used on any concrete surface ~~other than~~except as specified for concrete slope protection.

~~4.23.2~~During the cure period the Contractor shall provide protection such that the temperature of the centre of the in-situ concrete does not fall below 10°C or exceed 70°C and the temperature differential between the centre and any surface does not exceed 20°C. In addition, the requirements of Table 20, Maximum Permissible Temperature Differential between Concrete Surface and Ambient to minimize Cracking, of CSA A23.1 shall apply.

When a concrete element has a minimum dimension of 1.5 m, the Contractor shall supply and install two thermocouples, one in the centre and one at the surface of the concrete for every 50 m<sup>3</sup> of concrete, at locations determined by the Consultant. The Contractor shall monitor and record the temperatures every four hours for the first 72 hours after concrete placement and every 8 hours thereafter for the specified cure period and until 24 hours after the maximum temperature has occurred. Daily temperature records shall be forwarded to the Consultant.

Concrete shall be cured for the specified time period and achieved a compressive strength acceptable to the Consultant, prior to being exposed to construction or traffic loads.

#### ~~4.22.24.23.2~~ Curing Requirements for Concrete Slope Protection

Concrete slope protection shall receive 2 coats of a Type 2 curing compound meeting the requirements of ASTM C309 or ASTM C1315. The first coat is to be applied immediately after the concrete has been ~~satisfactorily~~ finished, and the second coat is to be applied within 3 hours after the application of the first coat. Each application shall be at a rate specified by the Manufacturer.

#### ~~4.22.34.23.3~~ ~~4.23.3~~ Curing Requirements for Class HPC and Class HPC with Steel Fibres

The Contractor shall prepare and submit details for his proposed curing procedures to the Consultant for review and acceptance a minimum of two weeks prior to the scheduled pour date. At a minimum, the details shall include a description of equipment, materials, and work methods/techniques employed to carry out the work.

~~During the cure period the Contractor shall provide protection to ensure that the temperature of the centre of the in-situ concrete shall not fall below 10°C or exceed 60°C and the temperature difference between the centre and the surface shall not exceed 20°C. In addition, the requirements of Table 21 of CSA A23.1 shall apply. The Contractor shall supply and install two thermocouples, one in the centre and one at the surface of the concrete, for every 100 m<sup>2</sup> of deck, at locations determined by the Consultant. The Contractor shall monitor and record the temperatures every four hours for the first 72 hrs after concrete placement and every 8 hours thereafter for the remainder of the specified cure period. Daily temperature records shall be forwarded to the Consultant.~~

Immediately after final bull floating and/or surface texturing an evaporation reducer, such as "Confilm" manufactured by BASF or an approved equivalent, having a monomolecular film forming compound intended for application to fresh concrete for temporary protection against moisture loss, shall be applied by a hand sprayer with a misting nozzle at the manufacturer's recommended concentration and application rate.

Two layers of ~~Nilex 4504~~ white filter fabric, Nilex 4504 or an approved equivalent shall be placed on the concrete surface as soon as the surface will not be marred by its installation. The fabric shall be pre-wet or a fine spray of clean water immediately applied once placed. Edges of the filter fabric shall overlap a minimum of 150 mm and be held in place without marring the surface of the concrete. The filter fabric shall be kept in a continuously wet condition throughout the curing period by means of soaker hoses or other means reviewed and accepted by the Consultant. The use of polyethylene sheeting above the two layers of filter fabric to reduce moisture loss will only be permitted if the sheeting is manufactured with regular perforations to permit the adequate application of curing water from above and reduce the heat generated by greenhouse effects.

~~Curing with filter fabric and water~~ Wet curing shall be maintained for a minimum of 7 days for rehabilitation projects and 14 days for new bridge construction. When concreting in cold weather, curing with filter fabric and water shall be maintained for a minimum of 14 days followed by 73 days of air drying for both rehabilitation and new bridge construction projects.

~~Wet curing of deck joint blockout concrete for rehabilitation projects can be reduced to 3 days followed by the application of a Type 2 curing compound meeting the requirements of ASTM C309 or ASTM C1315.~~

~~For those locations where~~ When formwork is removed prior to the completion of ~~this~~ the specified curing period, the resulting exposed concrete surfaces shall be wet cured for the remaining days.

Curb and barrier formwork shall be removed such that the concrete is not damaged by removal operations, but no later than 72 hours after concrete placement. Wet curing of the concrete surfaces exposed after formwork removal, shall commence immediately after formwork removal.

In the event that curing is unacceptable, or any portion of the HPC or HPC with steel fibres becomes surface dry during the curing period, the Consultant will have cause to reject the concrete.

#### ~~4.24 Concrete Finishing Under Bearings~~

#### ~~4.24 Concrete on which bearing plates, pads~~ Repairing Concrete Defects

~~Honeycomb, cavities, spalls, chips, cracking and other casting or shims are to be placed~~ construction defects shall be immediately reported to the Consultant. Repair procedures shall be developed by the Contractor and submitted for review and acceptance by the Department and Consultant prior to the commencement of the repair. Damaged concrete shall be repaired by the Contractor at his own expense to the satisfaction of the Consultant.



#### 4.24.1 Honeycomb, Cavities, Casting Defects

~~finished~~Honeycomb, cavities and other deficiencies are defined as those areas that are greater than 30 mm in depth or 0.05 m<sup>2</sup> in area. Defects less than 30 mm in depth and 0.05 m<sup>2</sup> in area shall be repaired in accordance with Subsection 4.25.3, Class 2 Rubbed Surface Finish.

As a minimum, the Contractor's repair procedure shall include removing and replacing the defective concrete with the originally specified class of concrete. Repair extents shall be saw cut 25 mm deep in neat perpendicular lines and concrete removed to a depth of 35 mm below reinforcing steel. Repair areas shall be roughened to remove all loose material and laitance. Exposed reinforcing steel shall be cleaned and repaired to its original condition. Repair areas shall be saturated with water for a period of 24 ~~ground to a smooth and even~~hours prior to concrete placement. Repair areas shall be free of standing water and ~~surface-~~dry immediately prior to concrete placement. Curing shall be in accordance with the requirements for the class of concrete.

~~Formwork misalignment for highly visible elements, including medians, curbs, barriers, exterior deck fascia, pier shafts, and exterior faces of wingwalls shall be such that when checked with a 1.2 m long~~ straight edge placed anywhere in any direction on the ~~concrete~~ surface, there shall not be any gap greater than 43 mm between the bottom of the straight edge and the concrete surface. The gap for formwork misalignment of all other elements shall not be greater than 5 mm. Concrete elements with formwork misalignments exceeding the allowable tolerances shall be repaired or replaced as determined by the Department.

#### 4.24.2 Cracks

For class HPC and HPC with steel fibres the Contractor and the Consultant shall jointly inspect and identify all cracks after the curing period and before opening to traffic. The Consultant will plot the width in millimeters and length in linear meters of cracks and report the findings to the Department. Cracks that are determined by the Department and Consultant to be design related shall be repaired by the Contractor as extra work. The Contractor shall complete all required crack repairs prior to opening to traffic. Cracks that develop after opening to traffic will not require repair.

The Contractor shall repair cracks with widths greater than or equal to 0.2 mm using the following procedure:

- (1) Clean and dry cracks with oil-free compressed air.
- (2) Seal cracks with a gravity flow concrete crack filler in accordance with the Manufacturer's recommendations. The crack filler shall maximize the penetration by taking into consideration the ambient temperature, substrate temperature, viscosity and pot life of the material. The crack filler shall be chosen from the Alberta Transportation Product List/Crack Treatment/Concrete Crack filler/Proven Products and have a viscosity less than 105 centipoises (cP).

(3) When cracks extend the full depth of the deck slab, barriers or curbs or extend partial depth of decks that are cast to grade, epoxy injection will be required. The epoxy resin shall meet the requirements of ASTM C881 Type IV, Grade 1, Class B or C and have a viscosity less than 500 cP. An injection procedure shall be submitted to the Consultant for review and acceptance prior to commencing repairs.

For all other classes of concrete, cracks 0.2 mm or greater in width identified prior to issuance of the construction completion certificate, shall be repaired by epoxy injection in accordance with the manufacturer's recommendations. The epoxy for crack injection shall meet the requirements of ASTM C881 Type IV, Grade 1, Class B or C. The viscosity shall not exceed 500 cP.

All costs associated with crack repairs will be considered incidental to the Work and no separate or additional payment will be made.

~~Air voids created by forming grout pad recesses shall be filled with an approved patching material a minimum of 7 days in advance of girder erection. In cold weather conditions this work shall be completed while the substrate concrete is warm from hydration processes. If the filling of air voids does not occur while the substrate concrete is still warm it shall be carried out in accordance with Section 4.21.~~

~~4.234.25~~ **4.25—Concrete Surface Finish**

~~4.23.14.25.1~~ **4.25.1—General**

Wood or magnesium tools shall be used for finishing concrete and be of a type and quality acceptable to the Consultant. Finishing aids are not permitted during any concrete finishing operations.

~~General~~

On exposed concrete surfaces to 600 mm below grade or, in the case of river piers, 600 mm below lowest water level, surface finishes shall be applied as follows:

Class 1 Ordinary Surface Finish

- All concrete surfaces unless other finishes are specified
- Top surfaces of pile caps, abutment seats, and pier caps

Class 2 Rubbed Surface Finish

- ~~————~~ Piers except grade separation piers (all surfaces except top surfaces of pier caps)
- Traffic side surfaces of curbs, barriers, medians and sidewalks
- Top surfaces of curbs and barriers
- Cast-in-place concrete girders except exterior fascia.

Class 3 Bonded Concrete Surface Finish\*

- ~~————~~ Abutment seats except top surface
- ~~————~~ ~~Pier caps except top surface~~
- ~~————~~ Exterior faces of curtain walls/wingwalls,
- Cast-in-place walls, MSE wall panels, and wall copings
- ~~————~~ Grade separation piers except top surfaces
- ~~————~~ Exterior concrete girder faces
- ~~————~~ Exposed end surfaces of cast -in -place concrete diaphragms
- ~~————~~ Underside of the deck overhang to top flange of girder
- ~~————~~ Exterior surfaces of deck slab, curb, barrier and sidewalk

\*~~Class 3 bonded concrete surface finishes shall only be applied to the above listed components~~ elements when specified in the Special Provisions of the Contract. When a Class 3 surface finish is not specified in the Special Provisions of the Contract, all above listed ~~components shall receive a Class 2 finish~~ elements shall receive a Class 2 finish. When specified in the Special Provisions of the Contract the extents of the Class 3 bonded concrete surface finishes shall be in accordance with Standard Drawings S-1851, Standard Concrete Sealer Surface Treatment for Major Bridges and/or S-1852, Standard Concrete Sealer Surface Treatment for Standard Bridges.

Class 4 Floated Surface Finish

- Top surfaces of concrete deck, roof slabs, and approach slabs which are to receive waterproofing membranes and wearing surfaces

Class 5 Floated Surface Finish, Broomed Texture

- ~~————~~ Top surfaces of ~~curbs, sidewalks, and medians,~~ and pedestrian bridge decks
- ~~————~~ Approach slab concrete which will be covered by a wearing surface only (without waterproofing membrane)
- Concrete slope protection
- deck joint blockout concrete top surfaces

Class 6 Floated Surface Finish, Surface Textured

- ~~————~~ Top surfaces of deck, deck overlay, roof and approach slabs which will not be covered with either waterproofing membrane or wearing surface

~~Wood or magnesium tools shall be used for finishing concrete and be of a type and quality acceptable to the Consultant.~~

~~4.23.24.25.2~~ 4.25.2 Class 1 Ordinary Surface Finish

~~4.23.2.14.25.2.1~~ 25.2.1 Unformed Surfaces

–Immediately following placing and consolidation, the concrete shall be screeded to conform to the required surface elevations, and then ~~trowelled~~floated to ensure that the surface is free from open texturing, plucked aggregate, and local projections or depressions.

Concrete surfaces shall be such that when checked with a 1.2 m long straight edge placed anywhere in any direction on the surface, there shall not be any gap greater than 3 mm between the bottom of the straight edge and the concrete surface unless otherwise specified.

~~4.23.2.24.25.2.2~~ 25.2.2 Formed Surfaces

–Immediately following the removal of forms, all fins and irregular projections shall be removed from all surfaces. On all surfaces the cavities produced by form ties, and all other holes, ~~honeycomb areas, broken corners or edges and other defects,~~ shall be thoroughly chipped out, cleaned, and shall be filled with ~~a Departmentan~~ approved concrete patching ~~product acceptable to material listed on~~ the ConsultantDepartment's Product List. The repair material shall be appropriate for the intended application and be placed in accordance with the manufacturer's ~~recommendations published product data sheet~~. All repairs shall be wet cured for a minimum of 72 ~~hrs~~hours. Curing compounds are not permitted.

~~4.23.34.25.3~~ 4.25.3 Class 2 Rubbed Surface Finish

Immediately following the removal of forms, all concrete fins and irregular projections shall be removed. ~~Prior to commencement of and~~ concrete finishing, surfaces ~~that do not meet tolerance requirements shall be corrected by grinding or partial depth repair as outlined in Section 20. Parging or surface patching to correct irregularities will not be permitted. On~~inspected for compliance with Subsection 4.24.1, Honeycomb, Cavities, Casting Defects. ~~After review and acceptance of the Consultant,~~ all surfaces, ~~the cavities produced by form ties, air bubbles and all other holes, honeycomb areas, broken corners or edges and any other defects,~~ shall be thoroughly exposed by brush abrasive blasting. Surfaces of piers, except grade separation piers and surfaces to receive a Class 3 surface finishes, may be thoroughly exposed by diamond grinding wheels or similar tools.

Surface voids greater than 19 mm diameter but less than 0.05 m<sup>2</sup> in area and less than or equal to 30 mm deep shall be filled with ~~a Departmentan~~ approved concrete patching material. ~~listed on the Department's Product list in the Overhead/Vertical (OH-V) category and placed in accordance with the manufacturer's published product data sheet~~. Surface voids less than 19 mm in diameter and less than or equal to 30 mm deep may be filled with a pre-bagged sack rub material. Sack rub materials shall be placed over the entire prepared surface in accordance with the manufacturer's recommendations. Both sack rub and patching materials shall be wet cured for a minimum of 72 ~~hrs~~hours. When the patching and sack rub materials have adequately cured, a carborundum stone or ~~approved equivalent methods~~method acceptable to the Consultant shall be used to finish the surface to a smooth, uniform and closed texture. Any voids or cavities opened during the stone rubbing process shall be re-~~filled~~ filled. ~~Parging or surface patching to correct irregularities will not be permitted.~~

Class 2 concrete surfaces shall be such that when checked with a 1.2 m long straight edge placed anywhere in any direction on the surface, there shall not be any gap greater than 3 mm between the bottom of the straight edge and the concrete surface unless otherwise specified.

~~It is essential that all of the~~All prepared concrete surfaces, including all patching and sack rubbing shall be uniform in colour and texture. After the surface preparation has been completed to the satisfaction of the Consultant, the Contractor shall apply sealer as specified in section 4.26 "Type 1c Sealer", required in Subsection 4.26, Type 1c Sealer. If application of the Type 1c sealer is applied in a uniform and manner acceptable to the Consultant, any subsequent change in the uniformity of concrete surface colour will be acceptable.

#### 4.25.4—Class 3 Bonded Concrete Surface Finish

##### 4.25.4 Surface preparation

Concrete surface finish shall be ~~done as specified for Class 2, "Rubbed Surface Finish", completed in accordance with Subsection 4.25.3, Class 2 Rubbed Surface Finish,~~ except that uniformity in colour and Type 1c Sealer is not required.

After the surface ~~preparation~~finish has been completed to the satisfaction of the Consultant, the concrete surface shall be pressure washed to remove all dust, dirt, laitance and all other bond breaking materials. After the concrete surface has dried for a minimum of 24 hours and before becoming contaminated with dust or other bond breaking materials, the Contractor shall apply an approved pigmented concrete sealer, which that meets the requirements for a Type 3 sealer of the Material Testing Specifications for Concrete Sealers - B388.

The pigmented concrete sealer shall be applied in accordance with the manufacturer's specifications and as a minimum two applications totaling the Department's approved application rate of the pigmented sealer are required. The colour(s) of the proposed coating scheme, which typically shall be similar to the natural colour of cured concrete, must be acceptable to the Department and Consultant before application of the coating. If a colour scheme has been designed for the site it will be specified in the Special Provisions. When spray application is used the surface shall be back rolled. The Contractor shall ensure that no colour variation is visible, and shall match the colour of any previously ~~coloured~~ coloured adjoining surfaces. Acceptance of the pigmented sealer used will not be considered to relieve the Contractor of full responsibility for its acceptable performance and appearance.

#### ~~4.23.44.25.5~~ 4.25.5—Class 4 Floated Surface Finish

Unless otherwise noted on the Drawings, concrete surfaces receiving a waterproofing membrane and a final wearing surface, shall be manually bull floated and ~~trowelled~~ float finished as necessary to provide a smooth surface.

4.25.6—Concrete surfaces shall meet the requirements of Subsection 4.16.6, Surface Defects and Tolerances.

#### 4.23.54.25.6 Class 5 Floated Surface Finish, Broomed Texture

The concrete surface shall be ~~floated and trowelled~~float finished as necessary to produce a smooth surface. The surface shall not vary more than 3 mm under a 3 m long ~~straight edge~~straight edge.

After the concrete has set sufficiently, the surface shall be given a transversely broomed finish using a coarse broom to produce regular corrugations to a maximum depth of 2 mm. ~~AA~~bronze edging tool shall be used at all edges and ~~expansion~~control joints. ~~Where indicated on the drawing, sidewalk surfaces shall~~

Sidewalk and median control joints shall be laid out in blocks installed at the same locations of curb/barrier control joints using an acceptable bronze grooving tool of sufficient gauge to produce control joints to a depth of a minimum one quarter of the slab thickness.

#### 4.23.64.25.7 ~~4.25.7~~ Class 6 Floated Surface Finish, Surface Textured

After the concrete has been manually bull floated, it shall be given ~~a suitable~~ texture with a “flat wire” texture broom having a single row of tines. The ~~desired~~ texture ~~is shall be~~ transverse grooving which may vary from 1.5 mm width at 10 mm centres to 5 mm width at 20 mm centres, ~~and the~~with a groove depth ~~shall be of~~ 3 mm to 5 mm. This work shall be done at such time and in such manner that the ~~desired~~ texture ~~will be is~~ achieved while minimizing the displacement of ~~the larger aggregate particles~~coarse aggregates or steel fibres. The textured surface shall be uniform ~~and consistent~~over the entire concrete surface.

Following surface texturing, a 300 mm width of concrete surface adjacent to the curb, barrier or median shall be trowelled smooth and the surface left closed.

#### ~~4.25.8 Repairing Concrete Defects~~

~~Honeycomb, cavities, cracking and other casting defects shall be immediately reported to the Consultant. Repair procedures shall be developed by the Contractor and submitted for review and acceptance by the Department and Consultant prior to the commencement of the repair. Damaged concrete shall be repaired by the Contractor at his own expense to the satisfaction of the Consultant.~~

#### ~~4.23.74.1.1 (a) Honeycomb, Cavities, Casting Defects~~

~~Honeycomb, cavities and other deficiencies are defined as those areas that are greater than 30 mm in depth or 0.05m<sup>2</sup> in area. Defects less than 30 mm in depth or 0.05m<sup>2</sup> in area shall be repaired in accordance with Section 4.25.3.~~

~~As a minimum, the Contractor's repair procedure shall include removing and replacing the defective concrete with the originally specified class of concrete. Repair extents shall be saw cut 25 mm deep in neat perpendicular lines and concrete removed to a depth of 35 mm below reinforcing steel. Repair areas shall be roughened to remove all loose material and laitance. Exposed reinforcing steel shall be cleaned and repaired to its original condition. Repair areas shall be saturated with water for a period of 24 hrs prior to concrete placement. Repair areas shall be free of standing water immediately prior to concrete placement. Curing shall be in accordance with the requirements for the class of concrete.~~

~~Formwork misalignment for highly visible components~~ Concrete surfaces shall meet the requirements of Subsection 4.16.6, Surface Defects and Tolerances.

#### 4.25.8 Surface Finish under Bearings

Air voids created in concrete surfaces of grout pad recesses shall be filled with an approved concrete patching material listed on the Department's Product List in the Normal Horizontal (NH) category and placed in accordance with the manufacturer's published product data sheet. The concrete patching material shall reach a compressive strength equal to or greater than the substrate concrete, prior to the commencement of installation of bearings and girder erection.

Concrete, including medians, curbs, barriers, exterior deck fascia, pier shafts, and exterior faces of wingwalls shall be such that air void patches, on which bearing plates, pads or shims are to be placed shall be finished or ground to a smooth and even surface. When checked with a ~~1.2 m long~~ straight edge placed anywhere in any direction on the concrete surface, there shall not be any gap greater than 31 mm between the bottom of the straight edge and the finished concrete surface.

This work shall be completed while the substrate concrete surface. The gap for formwork misalignment of all other components is at or above 5°C. When the substrate temperature is below 5°C, the Work shall be completed in accordance with Subsection 4.21, Concreting in Cold Weather.

#### 4.25.9 Surface Finish under Baseplates

Concrete surfaces of grout pad recesses shall be bush hammered to a depth of 3 mm including all air voids prior to the installation of bridgerail post, luminaire, overhead sign structure or other baseplates. Bush hammering shall not be greater than 5 mm. Concrete elements with formwork misalignments exceeding the allowable tolerances shall be removed and recast occur within 25 mm of anchor rods. Anchor rods shall be protected from damage during the Work.

#### ~~4.23.84.1.1~~ (b) Cracks

~~For class HPC and HPC with steel fibres the Contractor and the Consultant shall jointly inspect and identify all cracks after the curing period and before opening to traffic. The Consultant will plot the width in millimeters and length in linear meters of cracks and report the findings to the Department. The Contractor shall complete all required crack repairs prior to opening to traffic.~~

~~The Contractor shall repair cracks with widths greater than or equal to 0.2 mm using the following procedure:~~

- ~~(1) (i) Clean and dry cracks with oil free compressed air.~~
- ~~(2) (1) (ii) Seal cracks with a gravity flow concrete crack filler in accordance with the Manufacturer's recommendations. The crack filler shall maximize the penetration by taking into consideration the ambient temperature, substrate temperature, viscosity and pot life of the material. The crack filler shall be chosen from the Alberta Transportation Product List/Crack Treatment/Concrete Crack filler/Proven Products and have a viscosity less than 105 centipoises (cP).~~
- ~~(iii) When cracks extend the full depth of the deck slab, barriers or curbs or extend partial depth of decks that are cast to grade, epoxy injection will be required. The epoxy resin shall meet the requirements of ASTM C881 Type IV, Grade 1, Class B or C and have a viscosity less than 500 cP. An injection procedure shall be submitted by the Contractor to the Consultant for review and acceptance.~~

~~For all other classes of concrete, cracks 0.2 mm or greater in width identified prior to issuance of the construction completion certificate, shall be repaired by epoxy injection in accordance with the manufacturer's recommendations. The epoxy for crack injection shall meet the requirements of ASTM C881 Type IV, Grade 1, Class B or C. The viscosity shall not exceed 500 CPS.~~

~~All costs associated with crack repairs will be considered incidental to the Work and no separate or additional payment will be made.~~

#### ~~4.26~~ Type 1c Sealer

#### 4.26 ~~An approved Type 1c sealer~~

~~An approved Type 1c concrete sealer selected from the Alberta Transportation Products List shall be applied to all concrete surfaces which are to receive a Class 2, Class 5 and Class 6 surface finish. This shall include all concrete surfaces to 600 mm below grade or in the case of river piers 600 mm below lowest water level. Surfaces that are to receive a waterproofing membrane shall not have sealer applied. Sealer will not be required on the underside of bridge decks or on concrete diaphragms in the interior bay areas, however, the faces of the end diaphragms nearest the abutment backwalls, inside face of backwall and top surface of abutment seat, excluding bearing recess pockets, shall be sealed.~~

~~Type 1c sealers shall meet the current Material Testing Specifications for Concrete Sealers – B388.~~



The sealer shall be applied in accordance with the Manufacturer's recommendations; however the application rate shall be increased by 30% from that indicated on the ~~approved Product List~~ Alberta Transportation Products List and the substrate temperature shall be a minimum of 5°C. Before applying the sealer, the concrete shall be cured for at least 28 days. The concrete surface shall be dry, and air blasted to remove all dust and accepted by the Consultant prior to applying sealer. In order to ensure uniform and sufficient coverage rates the Contractor shall apply measured volumes of sealing compound to appropriately dimensioned areas of concrete surface, using a minimum of 2 coats. Asphalt concrete pavement surfaces and other elements shall be adequately protected from overspray and runoff during sealer application.

#### 4.27 Measurement and Payment

##### 4.27.1 ~~4.27~~ Concrete ~~Strength Requirements~~

Measurement for payment of cast-in-place concrete will be by the cubic metre of concrete acceptably placed, measured to the nearest 0.01 m<sup>3</sup>.

The quantity of concrete paid for will be the volume of concrete remaining within the neat lines as shown on the Drawings, less the volume of concrete displaced by steel pipe piles, concrete piles, ducts and voids, and girder flanges and webs. The volume of concrete displaced by H-Piles, reinforcing steel, deck joint anchorages, and anchor rods will not be deducted from the quantity to be paid for.

When calculating the volume of pile concrete for drilled piles at locations where the pile holes are drilled larger than specified, the additional volume of concrete required to fill the oversize pile hole will not be included in the quantity of material to be paid for.

Payment will be made at the unit prices bid for "Concrete – Supply and Place" for the class of concrete specified less any applicable payment adjustments for compressive strength, and will be full compensation for falsework and formwork; curing; concrete surface finishing; the supply and application of concrete sealers; testing and inspection; and all labour, materials, equipment, tools and incidentals necessary to complete the Work as shown on the Drawings and to the satisfaction of the Consultant.

All costs associated with concreting in cold weather, when required, will be considered incidental to the Work, and no separate or additional payment will be made.

80% of the unit price bid will be paid once the concrete has been acceptably placed and the 7 day concrete compressive strength tests indicate, in the opinion of the Consultant, that the concrete will achieve the specified strength. Initial payment will not constitute full acceptance of the concrete. The remaining 20% of the unit price bid will be made once concrete surface finishing has been acceptably completed, and the 28 day compressive strength test results have been reviewed and accepted by the Consultant.

The Department reserves the right to reject ~~any concrete whatsoever which that~~ does not meet ~~all the specified requirements for that class of concrete.~~ The Department may ~~however, at its sole discretion,~~ accept concrete, ~~the strength of which falls below that does not meet the specified strength requirements.~~ In this case, payment will be made in accordance with 4.27.1. The bid price can either be unit price or lump sum. Subsection 4.27.1.1, Compressive Strength Test Result Payment Adjustment.

#### 4.27.1.1 4.27.1 Compressive Strength Test Result Payment Scales Adjustment

Payment adjustment may be applied to the volume of concrete represented by the compressive strength test results in accordance with Subsection 4.9.1, Compressive Strength Tests.

#### Class C Concrete, 35 MPa

##### Strength Test Results

- 35 MPa and over, full bid price
- 34 MPa to 35 MPa, bid price less \$30 per cubic metre
- 33 MPa to 34 MPa, bid price less \$60 per cubic metre
- 32 MPa to 33 MPa, bid price less \$90 per cubic metre
- 31 MPa to 32 MPa, bid price less \$120 per cubic metre
- 30 MPa to 31 MPa, bid price less \$160 per cubic metre
- 29 MPa to 30 MPa, bid price less \$220 per cubic metre
- 28 MPa to 29 MPa, bid price less \$300 per cubic metre
- 27 MPa to 28 MPa, bid price less \$400 per cubic metre

#### Class HPC and Class HPC with Steel Fibres Concrete, 45 MPa

##### Strength Test Results

- Less than 27 MPa, rejected

#### Class HPC and Class HPC with Steel Fibres Concrete

- 45 MPa and over, full bid price
- 44 MPa to 45 MPa, bid Price less \$40 per cubic metre
- 43 MPa to 44 MPa, bid Price less \$100 per cubic metre
- 42 MPa to 43 MPa, bid Price less \$180 per cubic metre
- 41 MPa to 42 MPa, bid Price less \$280 per cubic metre
- 40 MPa to 41 MPa, bid Price less \$400 per cubic metre
- Less than 40 MPa, rejected

#### Class D, and Class Pile Concrete, 30 MPa

##### Strength Test Results

30 MPa and over ~~\_\_\_\_\_ Full bid price~~

- ~~29 MPa to 30 MPa \_\_\_\_\_, full bid price~~
- ~~29 MPa to 30 MPa, bid price~~ less \$30 per cubic metre
- ~~28 MPa to 29 MPa, bid price~~ less \$60 per cubic metre
- ~~27 MPa to 28 MPa, bid price~~ less \$90 per cubic metre
- ~~26 MPa to 27 MPa, bid price~~ less \$120 per cubic metre
- ~~25 MPa to 26 MPa, bid price~~ less \$160 per cubic metre
- ~~24 MPa to 25 MPa, bid price~~ less \$220 per cubic metre
- ~~Less than 24 MPa, rejected~~

Class S Concrete, 20 MPa

Strength Test Results

- 20 MPa and over, full bid price
- 18 MPa to 20 MPa, bid price less \$30 per cubic metre
- 16 MPa to 18 MPa, bid price less \$70 per cubic metre
- Less than 16 MPa, rejected

4.27.1.2 Coring ~~The reduced payment shall apply to the volume of~~

Coring to confirm or contest low concrete represented by the compressive strength test as defined in Section 4.9.1.

Concrete results will only be rejected with representative strengths less than the following: permitted when reviewed and accepted by the Department.

Sampling and testing of cores shall be completed by an independent laboratory certified to CSA A283 and in accordance with CSA A23.2 14C. Cores shall be extracted in the presence of the Consultant and tested within 7 days of the testing the 28 day cylinders that are being evaluated.

3 cores shall be extracted for each concrete compressive strength test result being evaluated. The core size shall be 100 mm diameter by 200 mm length or of a size acceptable to the Consultant.

Core hole locations will be determined by the Consultant. The Contractor shall use a reinforcing steel locator acceptable to the Consultant to locate reinforcing steel in the immediate vicinity of the core hole location and provide this information to Consultant. The Consultant will attempt to avoid reinforcing steel in his final determination of core hole locations. Core holes shall be repaired using a Department approved concrete patching product acceptable to the Consultant.

The average strength of each set of 3 cores will represent a concrete compressive strength test and shall be equal to or greater than the specified 28 day strength. CSA A23.1, Clause 4.4.6.6.2.2, Acceptance of Cores Drilled from a Structure, shall not apply. If the average cored concrete strength is greater than the averaged cylinder concrete strength, the concrete cored strength result will be used as the basis for acceptance and payment. If the averaged cored concrete strength is less than the averaged cylinder concrete strength, the averaged cylinder concrete strength will be used as the basis for acceptance and payment.

All costs associated with coring, testing, reporting and repairing core holes will be considered incidental to the Work, and no separate or additional payment will be made.

#### 4.27.2 Concrete Slope Protection

Measurement for payment of concrete slope protection will be by the square metre of concrete slope protection acceptably constructed, measured to the nearest 0.1 m<sup>2</sup>.

The quantity to be paid for will be based on horizontal measurement of surface areas perpendicular to the slope specified. Vertical faces will not be measured.

Payment will be made at the unit price bid for “Concrete Slope Protection” less any applicable payment adjustments for compressive strength, and will be full compensation for preparation of the slopes; supply, placement and compaction of backfill; formwork; the supply and placement of reinforcing steel, the supply and placement of concrete; supply and application of curing compound; and all labour, equipment, tools and incidentals necessary to complete the Work as shown on the Drawings and to the satisfaction of the Consultant.

All costs associated with top and toe cutoff walls, edge swales, galvanized steel flashing, fasteners, and associated materials will be considered incidental to the Work, and no separate or additional payment will be made.

The Department reserves the right to reject concrete slope protection that does not meet the specified requirements. The Department may, at its sole discretion, accept concrete slope protection that does not meet the specified 28 day concrete compressive strength. Payment may be made in accordance with Subsection 4.27.2.1, Compressive Strength Test Result Payment Adjustment.

##### 4.27.2.1 Compressive Strength Test Result Payment Adjustment

Payment adjustment may be applied to the area of concrete slope protection represented by the compressive strength test in accordance with Subsection 4.9.1, Compressive Strength Tests.

#### Class C Concrete – 27 MPa

- ~~▪ Class HPC and Class HPC with Steel Fibres Concrete – 40/35 MPa~~
- ~~• Class D and Pile concrete – 24 over, full bid price~~
- ~~▪ 34 MPa~~
- ~~▪ Class S concrete – 16 MPa~~

- ~~4.27.2 OPEN to TRAFFIC~~ 35 MPa, bid price less \$10 per square metre

~~The bridge shall not be opened to traffic until the deck concrete has attained minimum compression strength of 70% of the design strength. The concrete shall be cured in accordance with Section 4.23 of the specification. The Contractor shall be responsible for all costs associated with any additional testing that may be required to satisfy the strength requirement.~~

#### ~~4.27.3~~ Coring FOR COMPRESSIVE STRENGTH TESTING

~~Coring to confirm or contest low concrete strength test results shall be reviewed and accepted by the Department. When coring is acceptable, arrangements shall be made by the Contractor to employ an independent, certified testing laboratory, all at the expense of the Contractor. The cores shall be taken and tested within seven days of the testing of the twenty-eight day cylinders representing the concrete in question. Where practical, three 100 mm diameter cores shall be taken for each strength test previously taken, and there shall be no doubt that the cores taken, and the cylinders under consideration represent the same batch of concrete. Cores may not be taken unless the Consultant's representative is present. Cores shall be tested by an independent CSA certified laboratory and in accordance with the requirements of CSA Standard A23.2-14C. CSA Standard A23.1-09, Clause 4.4.6.6.2 "Cores drilled from a structure" shall not apply. The average strength of each set of three cores shall be equal to or greater than the 28-day specified strength. The average strength of the cores as reported by the independent testing service shall constitute a test.~~

~~In cases where the concrete strength, as indicated by the cores, is higher than the strength based on the concrete cylinder results, the core results shall be used as the basis for acceptance of and payment for the concrete. If the core strengths are lower than the strength from the concrete cylinder tests, the cylinder tests shall govern.~~

### ~~4.28~~ Measurement and Payment

#### ~~4.28.1~~ Concrete

~~Payment for the class of concrete specified will be made on the basis of the actual volume within the neat lines of the structures as shown on the drawings or as reviewed and accepted by the Department and Consultant. The volume of concrete displaced by ducts and voids, girder flanges/webs and by timber, pipe, or concrete piles will be deducted. No deduction will be made for the volume of concrete displaced by steel reinforcement, expansion material or steel H-piles, nor for fillets and chamfers.~~

~~When it is specified on the drawings that concrete in footings is to be placed against undisturbed soil or set in rock, and where the excavation is made wider than the neat lines of the footing as shown, the Contractor shall supply and place the excess volume of concrete at his own expense.~~

~~In the case of drilled cast-in-place concrete piles where the drilled holes are made larger than required by the drawings, the additional volume of pile concrete required to fill the enlarged hole shall be supplied and placed by the Contractor at his expense.~~

~~An interim payment in the amount of 80% of full value will be made if the concrete has been placed acceptably, and the 7 day test cylinder strength indicates that the concrete will reach the acceptance range of specified strength. Partial payment in advance of 28 day test results will not be deemed to constitute acceptance of the concrete nor limit in any way the requirements of Section 4.27 of these specifications.~~

~~Final payment will not be made until the specified concrete finish is acceptably completed, and the 28 day strength tests show that the concrete meets the strength requirement of the specification, or indicate what deduction is to be made for below strength concrete.~~

~~The payment for concrete shall include full compensation for the cost of furnishing all material, tools, equipment, falsework, forms, bracing, labour, curing, heating, surface finish including application of Type 1c sealer and/or Type 3 pigmented sealer and all other items of expense required to complete the concrete work shown on the drawings, and as outlined in the specifications.~~

#### ~~4.28.2 Concrete Slope Protection~~

~~Payment for **Concrete Slope Protection** will be made at the unit price bid per square metre, and shall include full compensation for the cost of furnishing all tools, labour, equipment, materials, and incidentals necessary for the completed work, including the preparation of the slopes, supply and placing of reinforcing steel, steel mesh, concrete, and backfilling. The quantity to be paid for will be the number of square metres satisfactorily placed, and shall include trough drains adjoining the slope protection and the vertical surfaces of toe cut-off walls. No payment will be made for top cut-off walls or edge walls.~~

- ~~• 33 MPa to 34 MPa, bid price less \$20 per square metre~~
- ~~• 32 MPa to 33 MPa, bid price less \$30 per square metre~~
- ~~• 31 MPa to 32 MPa, bid price less \$40 per square metre~~
- ~~• 30 MPa to 31 MPa, bid price less \$55 per square metre~~
- ~~• 29 MPa to 30 MPa, bid price less \$75 per square metre~~
- ~~• 28 MPa to 29 MPa, bid price less \$100 per square metre~~
- ~~• 27 MPa to 28 MPa, bid price less \$150 per square metre~~
- ~~• Less than 27 MPa, rejected~~

# STANDARD SPECIFICATIONS FOR BRIDGE CONSTRUCTION

## SECTION 5 REINFORCING STEEL

### TABLE OF CONTENTS

<b>5.1</b>	<b>General</b> .....	<b>5-1</b>
<b>5.2</b>	<b>Material Types</b> .....	<b>5-1</b>
5.2.1	Plain Reinforcing Steel.....	5-1
5.2.2	Epoxy Coated Reinforcing Steel.....	5-1
5.2.3	Corrosion Resistant Reinforcing Steel.....	5-1
5.2.4	Stainless Reinforcing Steel .....	5-2
5.2.5	Plain and Deformed Welded Wire Reinforcing .....	5-2
<b>5.3</b>	<b>Manufacture</b> .....	<b>5-3</b>
<b>5.4</b>	<b>Fabrication</b> .....	<b>5-3</b>
<b>5.5</b>	<b>Shipping, Handling and Storage</b> .....	<b>5-4</b>
<b>5.6</b>	<b>Placing and Fastening</b> .....	<b>5-5</b>
5.6.1	Supports .....	5-5
5.6.2	Field Modifications .....	5-6
5.6.3	Reinforcing Steel Tolerances for Cast-In-Place Concrete .....	5-6
<b>5.7</b>	<b>Splicing</b> .....	<b>5-7</b>
<b>5.8</b>	<b>Repair of Epoxy Coated Reinforcing Steel</b> .....	<b>5-7</b>
<b>5.9</b>	<b>Repair of Stainless Reinforcing Steel</b> .....	<b>5-7</b>
<b>5.10</b>	<b>Measurement and Payment</b> .....	<b>5-8</b>
5.10.1	Measurement.....	5-8
5.10.2	Payment.....	5-9
5.10.2.1	Supply .....	5-9
5.10.2.2	Placement.....	5-9





## 5.1 General

This Specification is for the supply, fabrication, handling and placing of plain reinforcing steel, epoxy coated reinforcing steel, corrosion resistant reinforcing steel (CRR), and stainless reinforcing steel. All reinforcing steel shall be supplied and installed in the lengths and shapes shown on the Drawings. No substitution of bars or changes to bar details will be permitted without prior approval of the Consultant.

## 5.2 ~~5.2~~ Material Types

### 5.2.1 ~~5.2.1~~ Plain Reinforcing Steel

Plain reinforcing steel shall be Grade 400, meeting the requirements of CSA Standard G30.18M.

### 5.2.2 ~~5.2.2~~ Epoxy Coated Reinforcing Steel

Plain reinforcing steel meeting the requirements of Subsection ~~5.2.15.2.1, Plain Reinforcing Steel~~, shall be used in the production of epoxy coated reinforcing steel.

Epoxy coated reinforcing steel shall be coated by a manufacturer certified under the Concrete Reinforcing Steel Institute (CRSI) Voluntary Certification program for Fusion -Bonded Epoxy Coating Applicator plants. Proof of certification shall be submitted to the Consultant prior to delivery of the material.

Epoxy coated reinforcing steel shall be prepared and coated in accordance with the requirements of Ontario Provincial Standard Specification OPSS 1442, Material Specification for Epoxy Coated Steel Reinforcement for Concrete, and the requirements contained herein.

The film thickness of the epoxy coating, after curing, shall be 175 µm to 300 µm (7 to 12 mils). The epoxy coating material shall conform to the requirements of OPSS 1443, Material Specification for Organic Coatings for Steel Reinforcement.

### 5.2.3 ~~5.2.3~~ Corrosion Resistant Reinforcing Steel

Corrosion resistant reinforcing steel (CRR) shall consist of either low carbon/chromium reinforcing steel or stainless reinforcing steel.

Low carbon/chromium reinforcing steel shall meet the requirements of ASTM A1035. The alloy type shall be CS and the minimum yield strength based on the 0.2% offset method shall be equal to 690 MPa.

Stainless reinforcing steel, if used, shall meet the requirements of Subsection ~~5.2.4, Stainless Reinforcing Steel~~. 5.2.4, Stainless Reinforcing Steel.

Unless otherwise specified, only one type of CRR shall be supplied for use throughout the project.

#### 5.2.4 Stainless Reinforcing Steel

Stainless reinforcing steel shall be of the following designations as defined by the Unified Numbering System (UNS):

- ~~S31653~~
- ~~S31603~~
- ~~S31803~~
- ~~S30400~~
- ~~S32304~~

Stainless reinforcing steel shall meet the requirements of ASTM A276 and ASTM A955/A955M (including Annex 1.2 or 1.3). The minimum yield strength shall be 420 MPa.

Austenitic grades shall meet the requirements of with ASTM A262, Practice E. Duplex grades shall meet the requirements of ASTM A1084, Method C by demonstrating no presence of detrimental phases.

Stainless reinforcing steel shall be shotblasted and pickled at the production mill to remove all mill scale and surface oxidation.

Unless otherwise specified, only one type of stainless reinforcing steel shall be supplied for use throughout the project.

#### **5.3—Material Production**Plain and **Testing**

##### 5.2.5 Deformed Welded Wire Reinforcing ~~steel~~

Plain and deformed welded wire reinforcement shall meet the requirements of ASTM A1064, Grade 70 ( $f_y = 485$  MPa) with a minimum yield strength of 485 MPa based on 0.2% offset. Welded wire reinforcement shall be ~~produced~~able to attain a minimum elongation of 4% at ultimate strength. Testing for elongation shall be in accordance with the Tension Test specified in ASTM A1064 with the following modifications:

- The minimum test gage length shall be 100 mm;
- 100% of the tests shall be across the welds; and
- The extensometer shall not be removed until 4% elongation has been attained.

The boron content shall not exceed 0.0008%.

### **5.3 Manufacture**

~~Reinforcing steel bars shall be manufactured and tested in accordance with the applicable standard(s).—Material manufacturer mill test certificates showing proof of compliance shall be submitted to the Consultant for review and acceptance prior to the placement of any reinforcing steel.~~

~~Mill test certificates shall be provided for each lot delivered to the site.~~

~~The following additional information, as applicable, shall be supplied for each lot of stainless reinforcing steel delivered to the site:~~

~~—Austenitic grades: Test results verifying compliance with ASTM A262, Practice E.~~

~~—Duplex grades: Test results verifying compliance with ASTM A923, Method A, by demonstrating an unaffected etched structure.~~

~~Stainless reinforcing steel shall be pickled to remove all mill scale and surface oxidation. Details of the Manufacturer's pickling process shall be included with the mill test certificate submissions.~~

~~**5.4**—Mill test reports for each heat number shall be legible and provided in English to the Consultant a minimum of 2 weeks prior to shipping to site. The Contractor shall maintain a tracking system and records for all reinforcing steel fabricated and installed and provide this information to the Consultant upon request. Mill test reports at a minimum shall include: heat number, date, and location of production, compliance with production standards, chemical analysis, mechanical properties, and pickling process details for stainless reinforcing steel. Mill test reports shall be authenticated by the manufacturer.~~

~~Where mill test reports originate from a mill outside Canada or the United States of America, the Contractor shall have mill test reports verified by a certified laboratory in Canada by testing the material to the specified material standards, including boron content. The testing laboratory shall be certified to ISO/IEC 17025 by an organization accredited by the Standards Council of Canada for the tests required. Samples for testing shall be collected by personnel employed by the certified laboratory. A verification letter shall be provided by the certified laboratory that includes at a minimum, the applicable mill test reports, testing standards, date of verification testing, and declaration of material compliance with Contract requirements. The verification letter shall be signed by an authorized officer of the certified laboratory.~~

~~The yield strength shall be determined using the offset method (0.2 %).~~

#### **5.35.4 Fabrication**

All bars requiring bends shall be cold bent at the fabrication facility. Heating of bars to facilitate bending will not be permitted.

Bars shall be cut by shearing or with fluid -cooled saws. Torch cutting will not be permitted. Bars showing evidence of torch cutting will be rejected.

Unless otherwise specified, all hooks and bends shall be fabricated using the pin diameters and dimensions recommended in the Reinforcing Steel Institute of Canada (RSIC) Manual of Standard Practice. Bars shall conform accurately to the dimensions shown on the Drawings, and be within the fabricating tolerances detailed in the RSIC Manual of Standard Practice.

Fabrication of epoxy coated reinforcing steel bars after application of the coating shall be in accordance with the requirements of Ontario Provincial Standard Specification OPSS 1442.

Fabrication of stainless reinforcing steel shall be carried out such that bar surfaces are not contaminated with deposits of iron or other non -stainless steels; or suffer damage due to straightening or bending. Stainless reinforcing steel fabrication facilities shall be exclusive to the fabrication of stainless reinforcing bars or in a facility that provides a permanent fixed physical barrier which fully isolates fabrication processes. Fabrication shall occur only on equipment dedicated solely to fabrication of stainless reinforcing steel bars. All machinery points that come into contact with stainless reinforcing steel bars shall consist of hardened steel to a minimum of 35 Rockwell, stainless steel, or nylon. All racking shall be protected with hardened steel to a minimum of 35 Rockwell, stainless steel, nylon or wood.

Reinforcing steel bars shall be fabricated without laminations or burrs.

#### **5.45.5 5.5 — Shipping, Handling and Storage**

Reinforcing steel shall be covered and protected at all times during transportation.

Lifting of stainless steel reinforcing shall be completed with nylon strapping dedicated to stainless steel reinforcing bars. Fork trucks used in the handling of coil or straight stainless reinforcing steel shall have their forks covered with hardened steel to a minimum of 35 Rockwell, stainless steel, or nylon. Stainless steel reinforcing bar bundles shall be tied with plastic strapping or stainless steel tie wire and not with carbon steel or epoxy coated carbon steel strapping.

Polyethylene wrap shall be used to fully cover all stainless reinforcing steel bars and bundles for shipping. Stainless steel reinforcing bars shall also be tarped at all times during shipping with tarps dedicated for stainless steel reinforcing bars.

Reinforcing steel of differing material types shall be stored separately. Bar tags identifying the material type shall be clearly visible and shall be maintained in-place until installation of the material.

The Contractor shall store all reinforcing steel on platforms, skids, or other suitable means of support able to keep the material above the ground surface while protecting it from mechanical damage or deterioration.

Special care shall be taken when handling epoxy coated reinforcing steel to prevent damage to the epoxy coating. Epoxy coated reinforcing bars shall not be dropped or dragged, and shall be lifted with non-metallic slings. Protective measure shall be implemented to prevent bar to bar abrasion and excessive sagging of bundles.

On-site storage of epoxy coated reinforcing steel shall not exceed 120 days, and exposure to daylight shall not exceed 30 days. If the daylight exposure time is expected to exceed 30 days, the Contractor shall protect the reinforcing steel by covering with opaque polyethylene sheeting or equivalent protective material acceptable to the Consultant.

On-site storage of all other types of reinforcing steel shall not exceed 120 days unless protected with polyethylene sheeting or equivalent protective material acceptable to the Consultant.

The Contractor shall take all precautions necessary to prevent damage to the material during handling operations. Bundles shall be handled with spreaders and ~~non-metallic~~nonmetallic slings, or by other methods acceptable to the Consultant. Damaged materials shall be replaced by the Contractor at his expense.

### ~~5.55.6~~ **5.6** — Placing and Fastening

~~Reinforcing steel incorporated into the work shall be free from loose rust, scale, dirt, paint, oil or other foreign materials.~~

Reinforcing steel shall be accurately placed and fastened in the positions shown on the Drawings, and ~~shall be~~ securely tied and chaired before placing the concrete. Bars shall be tied at all intersections except when the bar spacing is less than 250 mm in each direction; ~~alternate intersections may~~shall be tied ~~at these locations.~~ Specified distances from forms shall be maintained by supports, spacers, or other ~~means approved~~proposed means that have been reviewed and accepted by the Consultant.

~~Reinforcing cover~~Except as noted herein, tie-wire shall not be less than that specified on manufactured from the same material type as the reinforcing steel being tied. Plastic coated tie wire may be used where low carbon/chromium reinforcing steel is being placed. Where stainless reinforcing steel is being placed, tie-wire shall be stainless steel of any grade listed in Subsection 5.2.4, Stainless Reinforcing Steel.

Welding of reinforcing steel will not be permitted.

#### ~~5.6.1~~ Drawings. — Supports

Supports used to ~~prevent bars from contact with forms~~maintain the specified reinforcing steel concrete cover or for separation between layers of bars shall be of adequate strength, shape and dimension, and ~~approved~~accepted for use by the Consultant. Supports shall be either plastic or precast concrete. Where additional reinforcing support bars are proposed by the Contractor they shall be of the same material type and grade used in the Work. ~~and installed meeting concrete cover requirements.~~ Proposed supports and spacers fabricated from alternate material types may be used upon ~~approval~~review and acceptance by the Consultant.

Plastic bolster slab supports shall be Aztec Strong Back Slab / Beam Bolster - PSBB manufactured by Dayton Superior or an ~~approved~~equivalent acceptable to the Department. Bolster slab supports shall be staggered and configured to facilitate full concrete consolidation. Bolster slab supports of length not exceeding 100 mm shall be used for exposed faces of curbs, medians and barriers.

~~Precast concrete supports shall be used for all exposed faces of curbs, medians and barriers. Precast concrete supports shall be Total Bond Concrete Supports manufactured by Con Sys Inc or an approved equivalent. Precast concrete supports~~When precast concrete supports are used they shall have the compressive strength, rapid chloride permeability, and air content meeting the specification requirements for the class of concrete being placed.~~—~~and of a geometric configuration that minimizes dimensions and does not adversely affect concrete placement and consolidation processes. Brick or mortar chairs will not be permitted.

~~Except as noted herein, tie-wire shall be manufactured from the same material type as the reinforcing steel being tied. Plastic coated tie-wire may be used where low carbon/chromium reinforcing steel is being placed. Where stainless reinforcing steel is being placed, tie-wire shall be stainless steel of any grade listed in Subsection 5.2.4.~~

### 5.6.2 Field Modifications

~~Welding of reinforcing steel will not be permitted.~~

Field bending of reinforcing steel, regardless of circumstance, will not be permitted unless specified on the Drawings.

Any proposed field cutting of epoxy coated reinforcing steel shall be carried out only where necessary and approved reviewed and accepted by the Consultant. Cuts shall be made by shearing or saw cutting only. The epoxy coating on sheared or saw cut ends shall be patched in accordance with the specifications contained herein.

## **5.7—Splicing**

### 5.6.3 Reinforcing Steel Tolerances for Cast-In-Place Concrete

Reinforcing steel for cast-in-place concrete shall be placed in conformance with the following tolerances:

- Concrete cover:  $\pm 10$  mm, except concrete placed in contact with soil:  $\pm 25$  mm;
- Location, where the smallest dimension of the element is:
  - 200 mm or less:  $\pm 8$  mm;
  - Larger than 200 mm but less than 600 mm:  $\pm 10$  mm;
  - 600 mm or larger:  $\pm 20$  mm;
- Lateral spacing:  $\pm 30$  mm;
- Longitudinal location of bends and ends of bars:  $\pm 50$  mm; and
- Longitudinal location of bends and ends of bars at discontinuous ends:  $\pm 20$  mm.
- The clear distance between reinforcement shall not be less than 1.5 times the nominal diameter of the reinforcement, 1.5 times the maximum coarse aggregate size, or 40 mm.

**5.7 Splicing**

Splicing of bars, unless shown on the Drawings or ~~approved~~accepted in writing by the Consultant, ~~is prohibited~~will not be permitted.

Splices, where permitted, shall be staggered. For lapped splices, bars shall be placed in contact and ~~wired~~tied together while maintaining the minimum required clear distance to other bars and the required minimum distance to the surface of the concrete.

**5.65.8 5.8 — Repair of Epoxy Coated Reinforcing Steel**

The Contractor shall be responsible for the repair of all damage to epoxy coating up to the time the reinforcing steel is acceptably incorporated into the concrete. Where field cutting of the epoxy coated reinforcing steel is necessary and accepted by the Consultant, cutting shall be either shearing or saw cutting.

Repair of damaged coating and sheared or sawed ends shall be carried out using a two component epoxy coating patching material approved for use by the reinforcing steel Manufacturer.

Surface preparation and material application shall be completed in accordance with the patching material Manufacturer's written recommendations; the following requirements; and to the satisfaction of the Consultant. The areas to be repaired shall be cleaned by removing all surface contaminants and damaged coating before applying the patching material. Where rust is present, it shall be completely removed immediately prior to application of the patching material. The patching material shall be overlapped onto the original coating for a minimum distance of 25 mm or as recommended by the patching material Manufacturer. The dry film thickness of the patched areas shall be between 175 µm and 300 µm.

All costs associated with the repair of damaged epoxy coating will be considered incidental to the Work, and no separate or additional payment will be made.

**5.75.9 5.9 — Repair of Stainless Reinforcing Steel**

Individual stainless ~~steel~~-reinforcing steel bars exhibiting any of the following defects shall be repaired or replaced ~~at~~by the ~~Contractor's~~Contractor at his expense:

- ~~Any single area~~location of contamination from grinding or cutting slag;
- Any location of iron contamination greater than 100 mm in length~~;~~;
- ~~Two or more areas of iron contamination greater~~More than 50~~10 discrete points~~<sup>(1)</sup>of iron contamination on bar deformations within any 1000 mm ~~in~~of bar length~~;~~;
- ~~Frequent small occurrences~~More than 20 discrete points<sup>(1)</sup>of iron contamination along on bar deformations per bar; or

- More than 5 discrete points<sup>(1)</sup> of iron contamination that are not located on bar deformations per bar.

Notes:

- (1) A discrete point is defined as an area of contamination less than or equal to 5 mm<sup>2</sup>. If any area of contamination is larger than 5 mm<sup>2</sup>, the full length of area shall be divided by 5 to determine the bar number of discrete points.

Bars exhibiting excessive staining, as determined by the Consultant, shall have the contaminants identified by energy dispersive x-ray analysis (EDXA). Contaminant identification shall be carried out by the Contractor at his expense.

Methods proposed for the repair of stainless reinforcing steel bars shall be ~~approved~~reviewed and accepted by the Department and Consultant prior to implementation.

Stainless reinforcing steel bars exhibiting signs of mechanical damage shall be replaced.

## 5.10 ~~5.10~~—Measurement and Payment

### ~~5.7.15~~5.10.1 Measurement

#### ~~5.10.1~~—Measurement

~~Steel for payment of reinforcing incorporated in the concrete steel~~ will be by the kilograms of reinforcing steel acceptably supplied and placed, measured ~~in kilograms, to the nearest kilogram.~~

The quantity to be paid for will be based on the total computed mass for the size and length of bars as shown on the Drawings or reviewed and accepted by the Consultant.

Any proposed substitution of imperial reinforcing steel for metric reinforcing steel ~~must~~shall be reviewed and ~~approved~~accepted by the Consultant prior to commencement of the substitution taking place. ~~Work.~~ The nominal cross-sectional area of metric and imperial bar sizes used for evaluating substitutions will be in accordance with ASTM A1035, ASTM A955/A955M and CAN/CSA G30.18, respectively.

The mass for all reinforcing steel will be calculated as follows:

Metric Bar Designation	10M	15M	20M	25M	30M	35M	45M	55M
Imperial Bar Designation	4	5	6	8	9	11	14	18
Mass (kg/m)	0.785	1.570	2.355	3.925	5.495	7.850	11.775	19.625



5.7.25.10.2 ~~5.10.2~~ PaymentSupply~~5.10.2.1~~ ~~5.10.2.1~~~~Payment~~ Supply

~~Payment for the supply of reinforcing steel~~ will be made at the unit prices bid ~~per kilogram~~ for “Plain Reinforcing Steel ~~— Supply~~”, “Epoxy Coated Reinforcing Steel ~~— Supply~~”, “Corrosion Resistant Reinforcing Steel ~~— Supply~~” ~~or~~, “Stainless Reinforcing Steel ~~— Supply~~”, or “Plain and Deformed Welded Wire Reinforcing — Supply”, as applicable, and will be full compensation for the supply and fabrication of reinforcing steel; delivery to the project site; and all labour, ~~materials~~, equipment, tools and incidentals necessary to complete the Work to the satisfaction of the Consultant.

When stainless steel is supplied for use where CRR is specified, payment will be made at the unit price bid for “Corrosion Resistant Reinforcing Steel - Supply” ~~—~~ and no separate or additional payment will be made.

~~Payment will be made for~~ 90% of the unit price bid ~~for material~~ will be paid once the reinforcing steel has been acceptably supplied and delivered to the project site. ~~Payment for the remainder~~ The remaining 10% of the unit price bid will be made as the ~~materials are~~ reinforcing steel is acceptably ~~installed~~ placed and tied in the design position within the specified tolerances.

All costs associated with the handling ~~and~~, storage and protection of reinforcing steel will be considered incidental to the Work, and no separate or additional payment will be made.

~~5.7.2.15.10.2.2~~ ~~5.10.2.2~~ Placement

Payment for the ~~installation~~ placement of reinforcing steel will be made at the unit price bid ~~per kilogram~~ for “Reinforcing Steel - Place” ~~for steel acceptably placed and remaining in the work,~~, regardless of type; and will be full compensation for all labour, equipment, tools and incidental necessary to complete the Work. ~~No allowance~~ as shown on the Drawings and to the satisfaction of the Consultant.

Payment for the placement of reinforcing steel will only be made for once the concrete of the component containing the reinforcing steel has been acceptably placed.

All costs associated with the supply and installation of tie wire, chairs or other materials used for supporting, placing and fastening the reinforcing steel in place, will be considered incidental to the Work, and no separate or additional payment will be made.



# STANDARD SPECIFICATIONS FOR BRIDGE CONSTRUCTION

## SECTION 6 STRUCTURAL STEEL

### TABLE OF CONTENTS

<b>6.1</b>	<b>General</b>	<b>6-1</b>
<b>6.2</b>	<b>Supply and Fabrication</b>	<b>6-1</b>
6.2.1	Standards	6-1
6.2.2	Qualification	6-1
6.2.3	Engineering Data	6-2
6.2.3.1	Review of Plate Arrangement for Welded Girders	6-2
6.2.3.2	Welding Procedures	6-3
6.2.3.3	Shop Drawings	6-3
6.2.3.4	Proposed Fabrication Sequence and Equipment	6-4
6.2.3.5	Mill Test Reports	6-4
6.2.3.6	Schedules	6-5
6.2.4	Materials	6-5
6.2.4.1	Structural Steel	6-5
6.2.4.2	Bolts	6-6
6.2.4.3	Stud Shear Connectors	6-6
6.2.4.4	Bearings	6-6
6.2.5	Welding	6-6
6.2.5.1	Filler Metals & Welding Processes	6-6
6.2.5.1.1	Submerged Arc Welding (SAW)	6-7
6.2.5.1.2	Shielded Metal Arc Welding (SMAW)	6-7
6.2.5.1.3	Metal Core Arc Welding (MCAW)	6-7
6.2.5.2	Cleaning Prior to Welding	6-7
6.2.5.3	Tack and Temporary Welds	6-8
6.2.5.4	Run-off Tabs	6-8
6.2.5.5	Preheat and Interpass Temperatures	6-8
6.2.5.6	Welding at Stiffener Ends	6-8
6.2.5.7	Submission of Repair Procedures	6-8
6.2.5.8	Arc Strikes	6-9
6.2.5.9	Grinding of Welds	6-9
6.2.5.10	Plug and Slot Welds	6-9
6.2.5.11	Welding to Girder Flanges and Webs	6-9
6.2.6	Fabrication	6-9
6.2.6.1	Heat Number Transfer	6-10
6.2.6.2	Marking Systems	6-10
6.2.6.3	Cutting of Plate	6-10
6.2.6.4	Flange Stripping	6-10
6.2.6.5	Flame Cut Edges	6-10
6.2.6.6	Additional Material Splices	6-11
6.2.6.7	Vertical Alignment	6-11
6.2.6.8	Shop Assembly	6-11
6.2.6.8.1	Plate Girders	6-11
6.2.6.8.2	Box Girders	6-11
6.2.6.8.3	Drilling	6-12

6.2.6.9	Splice Plates.....	6-12
6.2.6.10	Bolt Holes.....	6-12
6.2.6.11	Dimensional Tolerances.....	6-12
	6.2.6.11.1 Combined Warpage and Tilt.....	6-13
	6.2.6.11.2 Girder Camber.....	6-13
	6.2.6.11.3 Box Girders.....	6-13
	6.2.6.11.4 Splices.....	6-13
	6.2.6.11.5 Splice Gap Between Adjacent Girder Ends.....	6-13
	6.2.6.11.6 Stiffeners.....	6-13
	6.2.6.11.7 Facing of Flanges.....	6-13
	6.2.6.11.8 Bearing to Bearing Dimension.....	6-14
6.2.6.12	Corner Chamfer.....	6-14
6.2.6.13	Stiffener Tolerances.....	6-14
6.2.6.14	Web Panning.....	6-14
6.2.6.15	Field Weld Preparation.....	6-14
6.2.6.16	Flame Straightening and Heat Curving.....	6-14
6.2.6.17	Stress Relieving.....	6-15
6.2.6.18	Handling and Storage.....	6-15
6.2.7	Surface Preparation and Coating.....	6-15
	6.2.7.1 Abrasive Blast Cleaning.....	6-15
	6.2.7.2 Coating.....	6-15
	6.2.7.3 Galvanizing.....	6-16
6.2.8	Testing and Inspection.....	6-17
	6.2.8.1 Access.....	6-17
	6.2.8.2 Responsibility.....	6-17
	6.2.8.3 Testing by the Consultant.....	6-17
	6.2.8.4 Testing by the Contractor.....	6-17
	6.2.8.5 Witness Points.....	6-18
	6.2.8.6 Non-destructive Testing.....	6-18
	6.2.8.7 Radiographic Inspection Schedule.....	6-19
	6.2.8.8 Radiographic Inspection of Welds for Miscellaneous Material....	6-19
	6.2.8.9 Magnetic Particle Inspection Schedule.....	6-20
	6.2.8.10 Dye Penetrant Inspection.....	6-20
	6.2.8.11 Hardness Tests.....	6-20
	6.2.8.12 Testing Stud Shear Connectors.....	6-21
	6.2.8.13 Inspection Schedules.....	6-21
	6.2.8.14 Notification to Ship.....	6-21
	6.2.8.15 Structural Steel Fabrication Outside of Canada.....	6-22
	6.2.8.16 Finger Plate and Cover Plated V-Seal Deck Joint Assemblies...	6-22
<b>6.3</b>	<b>Structural Steel Erection.....</b>	<b>6-23</b>
6.3.1	Transportation, Handling and Storing Materials.....	6-24
6.3.2	Bridge Girders.....	6-26
	6.3.2.1 Temporary Supporting Structures and Berms.....	6-26
	6.3.2.2 Girder Erection Procedure.....	6-27
	6.3.2.3 Fall Protection for Girder Erection and Deck Forming.....	6-29
	6.3.2.4 Straightening Bent Material.....	6-29
	6.3.2.5 Assembly.....	6-30
	6.3.2.6 High Tensile Strength Bolted Connections.....	6-30
	6.3.2.6.1 General.....	6-30
	6.3.2.6.2 Bolt Tension.....	6-31

6.3.2.6.3	Turn of Nut Tightening .....	6-32
6.3.2.6.4	Reuse of Fasteners .....	6-33
6.3.2.6.5	Inspection.....	6-33
6.3.2.7	Misfits .....	6-34
6.3.2.8	Girder Adjustment.....	6-34
6.3.2.9	Removal of Temporary Supporting Structures, Berms, and Clean-up.....	6-34
<b>6.4</b>	<b>Strip Seal and Cover Plated V-Seal Deck Joints .....</b>	<b>6-34</b>
<b>6.5</b>	<b>Payment .....</b>	<b>6-35</b>
6.5.1	Structural Steel .....	6-35
6.5.1.1	Supply .....	6-35
6.5.1.2	Delivery .....	6-35
6.5.1.3	Erection .....	6-36
6.5.2	Deck Joint Assemblies .....	6-36
6.5.2.1	Supply and Delivery .....	6-36
6.5.2.2	Installation .....	6-36



## 6.1 General

This specification is for the supply, fabrication, delivery and erection of structural steel ~~and associated materials.~~ Structural steel shall include steel girders, trusses, diaphragms, bracing, fasteners, splice plates, deck drains, anchor ~~bolts~~rods, dowels, deck joint assemblies, buffer angles, connector angles, anchor ~~bolt~~rod sleeves, curb, barrier, and median cover plates, trough plates, pier nose plates, steel caps, capitals, pier bracing ~~and~~, miscellaneous components and associated materials.

## 6.2 ~~6.2~~ Supply and Fabrication

A pre-fabrication meeting is required ~~prior to commencement of the supply and~~ fabrication of structural steel girders, trusses, cover plated v-seal and finger plate deck joint assemblies, or ~~when any other specialized construction is included in components as determined by the Contract Consultant.~~ The pre-fabrication meeting ~~will~~shall be held at ~~fabricator's plant~~the fabrication facility and the Contractor shall ensure that the ~~plant~~fabrication superintendent ~~and plant, fabrication~~ manager ~~responsible for the work and any manufacturer's representatives, and supervisors~~ directly involved in the ~~specialized~~ Work are in attendance. ~~The Department/Consultant will conduct this~~ The meeting after ~~the~~shall not occur until shop drawings, design notes and independent check notes (as applicable), and welding procedures have been reviewed. ~~The Contractor shall provide two week notice to and accepted by the Department/Consultant prior to.~~ The date of the pre-fabrication meeting shall be reviewed and accepted by the Consultant and the Department and proposed a minimum of 2 weeks prior to the anticipated date.

### 6.2.1 ~~6.2.1~~ Standards

Fabrication of structural steel shall conform to "AASHTO LRFD Bridge Construction Specifications" and the American Welding Society (AWS) - Bridge Welding Code D1.5.

~~Where imperial/metric conversions are necessary, The National Standard of Canada, CAN3-Z234.1-79 shall be used as the basis of conversion.~~

All welding, cutting and preparation shall be in accordance with the AWS - Bridge Welding Code, D1.5. The fabrication of steel structures composed of structural tubing shall be in accordance with the American Welding Society (AWS) – Structural Welding Code D1.1.

### 6.2.2 ~~6.2.2~~ Qualification

~~The Contractor~~Structural steel shall ~~notify the Department~~be supplied and ~~Consultant two weeks prior to fabrication of any subcontractors in his employ.~~ ~~The Contractor shall remain responsible for the work of the subcontractors.~~ ~~All terms of the contract, such as fabricated by a fabricator certified by the Canadian Welding Bureau (CWB) approval and Canadian Institute of Steel Construction (CISC) certification and right of access shall apply to the subcontractor.~~

~~The fabricator shall operate a recognized steel fabricating shop accepted by the Consultant.~~

~~The fabricator shall be fully approved by the CWB as per in accordance with W47.1 of the Canadian Standards Association (CSA) Standard W47.1 in the following Divisions as follows:~~

Fabrication of steel girders, girder components and <del>welded</del> steel trusses .....	Division 1
All other bridge components.....	Division 1 or Division 2
Field welding/repairs .....	Division 1 or Division 2

~~In addition~~ Fabricators of steel girders, girder components and ~~welded~~ steel trusses shall also be certified by the Canadian Institute of Steel Construction (CISC) ~~as meeting the quality compliance requirements~~ in the category of steel bridges.

~~Only~~ The Contractor shall notify the Consultant and the Department of fabricators in his employ. The Contractor shall remain responsible for the Work of fabricators. All terms of the Contract shall apply to fabricators.

Welders, welding operators and tackers shall be CWB approved ~~by the CWB~~ in the ~~particular applicable~~ category ~~shall be permitted to perform weldments.~~ Their qualifications shall be current and available for examination by the Consultant upon request.

### 6.2.3 ~~6.2.3~~ Engineering Data

#### 6.2.3.1 ~~6.2.3.1~~ ~~Review of Plate Arrangement for Welded Plate Girders~~ Review of Plate Arrangement for Welded Girders

~~Prior to the placing of material orders, the Contractor shall submit to the Department and Consultant for review, three copies of sketch drawings showing the general description of the proposed fabrication scheme. This shall include the general arrangement of plates or shapes, the location of all shop and field splices and such other information as may be requested by the Department and Consultant to permit an assessment of the acceptability of the proposal.~~

6.2.3.2 If modification to the splice locations or details specified on the Drawings are proposed, the Contractor shall submit design notes, check notes, and shop drawings signed and sealed by his design engineer of record and by an independent checker. The design engineer of record and the independent checker shall be Professional Engineers registered in the Province of Alberta. Design notes, independent check notes and shop drawings shall be submitted to the Consultant for review and acceptance a minimum of 4 weeks in advance of the commencement of fabrication. Review comments provided by the Consultant and/or the Department shall be incorporated into the design notes, independent check notes and shop drawings and resubmitted to the Consultant for review and acceptance prior to the commencement of fabrication. The design engineer of record and independent checker shall submit separate signed and sealed design notes and check notes. The design and independent check notes shall be presented in a legible and logical format, clearly identify material properties, and sufficiently detailed to allow a technical review of design concepts and assumptions used.



The independent checker may be employed by the same company as the design engineer of record. The independent check must be completed fully independent of the design engineer of record, including a complete re-analysis of all aspects of the design including calculations and engineering, preferably by a methodology or computer program other than that used by the design engineer of record. The design engineer of record and independent checker shall ensure that the shop drawings are complete and accurately convey the design criteria and assumptions used in their designs.

The design notes, independent check notes, and shop drawings will be reviewed by the Consultant solely to ascertain general conformance with codes and specifications. The Consultant's review and acceptance shall not be considered as relieving the Contractor of the responsibility for completing the Work in accordance with the Contract requirements.

### 6.2.3.2 Welding Procedures

Welding procedures, including welding procedure datasheets, shall be submitted for each type of weld ~~used in the structure proposed.~~ The welding procedures shall bear the approval of the CWB and ~~shall also be reviewed and accepted by the Consultant and the Department and Consultant~~ a minimum of 4 weeks prior to use on the structure commencement of fabrication.

### 6.2.3.3 ~~6.2.3.3~~ Shop Drawings

~~Five copies of the Shop drawings showing all details shall be prepared by the Contractor and submitted to the Consultant for review prior to and acceptance a minimum of 4 weeks in advance of the commencement of fabrication. Review comments provided by the Consultant and/or the Department shall be incorporated into the shop drawings shall be legible and of adequate quality to and resubmitted to the Consultant for review and acceptance prior to the commencement of fabrication.~~

~~Shop drawings shall be reproduced and microfilmed~~ electronic unlocked PDF format. Each shop drawing shall include the Department's shop drawing identification block and have a sufficient blank space for the Consultant's review stamp. The Consultant's review of the shop drawings shall not be construed as relieving the Contractor from his responsibility for errors or omissions. All shop drawings will be stamped as follows:

~~"This review applies to general arrangements and details of design but not to dimensions or details of fabrication and is subject to the requirements of specifications and to such corrections as may be marked here~~ The Department's shop drawing identification block will be provided to the Contractor upon request. As a minimum, the following information shall be included on:" ~~shop drawing submissions:~~

~~Fabrication shall not commence prior to the review of the shop drawings.~~

~~In addition to specific details, the shop drawings shall include the following:~~

- ~~(a) Drawings showing details of connections designed by the Contractor shall bear the signature and stamp of a Professional Engineer registered in the Province of Alberta.~~

- ~~(b)~~ — All dimensions shall be correct at 20 °C unless otherwise noted.
- ~~(c)~~ — Weld procedure identification shall be shown on the shop drawings in the tail of the weld symbols.
- ~~(d)~~ — All material splice locations shall be shown on the drawings.
- ~~(e)~~ — Bearings shall be centered at -5 °C.
- ~~(f)~~ — Shop assembly drawings shall indicate camber and splice joint offsets measured to the top of top flange at a maximum spacing of 4 m.
- ~~(g)~~ — ~~Alberta Transportation bridge file number~~ Sizes of hardware, shear stud connectors, and project name shall be any other material shown on all the shop drawings shall be in the actual units (imperial or metric) of the material being supplied.

6.2.3.4 The shop drawings will be reviewed by the Consultant solely to ascertain general conformance with codes and specifications. The Consultant's review and acceptance shall not be considered as relieving the Contractor of the responsibility for completing the Work in accordance with the Contract requirements.

The Contractor shall incorporate as-built construction conditions into shop drawings. One paper copy and one electronic copy (PDF format) of as-built shop drawings shall be submitted to the Consultant within 3 weeks of construction completion.

#### 6.2.3.4 Proposed Fabrication Sequence ~~&~~ and Equipment

~~Prior to commencement of fabrication,~~ The Contractor shall ~~present for review~~ submit an outline of the proposed fabrication sequence and ~~details of equipment which that~~ will be used to the Consultant for review and acceptance 4 weeks prior to the commencement of fabrication. The fabrication ~~The fabrication scheme sequence~~ shall include the order of ~~make-up and fabrication, identification of witness points, details of shop assembly of all the component parts, as well as shop assembly, inspection stations, and,~~ and the details of surface preparation, ~~and coating.~~

The details of shop assembly shall include the method of assembly, support point locations, dimensional checks, methods of trimming to length, drilling and marking of splices.

If ~~any~~ equipment causes repeated ~~defective work~~ occurrences of damage, as determined by the Consultant and the Department/Consultant, it shall be ~~substituted with a suitable alternative~~ removed and replaced to the satisfaction of the Consultant.

#### 6.2.3.5 — Mill Certificates

##### 6.2.3.5 Mill certificates Test Reports

Mill test reports shall be provided for all ~~material before~~ materials in English.

Mill test reports shall be submitted to the Consultant for review and acceptance 4 weeks prior to the commencement of fabrication ~~commences.~~

~~6.2.3.6~~ Where mill test reports originate from a mill outside Canada or the United States of America, the Contractor shall have mill test reports verified by a certified laboratory in Canada by testing the material to the specified material standards, including boron content. The testing laboratory shall be certified to ISO/IEC 17025 by an organization accredited by the Standards Council of Canada for the tests required. Samples for testing shall be collected by personnel employed by the certified laboratory. A verification letter shall be provided by the certified laboratory that includes at a minimum, the applicable mill test reports, testing standards, date of verification testing, and declaration of material compliance with Contract requirements. The verification letter shall be signed by an authorized officer of the certified laboratory.

#### ~~6.2.3.5~~ 6.2.3.6 Schedules

The Contractor shall provide and keep current a complete ~~fabrication~~fabrication schedule in a form satisfactory to the Consultant.

### 6.2.4 ~~6.2.4~~ Materials

#### 6.2.4.1 ~~6.2.4.1~~ Structural Steel

Structural steel shall conform to the standard noted on the Drawings. ~~Interpretation of equivalent steels will be as per Appendix "A" of the CSA Standard G40.21 (1976 only). Mill certificate data~~ Mill test reports and results of impact tests shall be provided to the Consultant for review and acceptance prior to shipment of material from the mill to provide sufficient time for replacement or for heat treating of material that does not meet the specification. If any material cannot be identified by mill test reports, coupons shall be taken and tested at a certified laboratory in Canada in accordance with Subsection 6.2.3.5, Mill Test Reports. Mill test reports shall be submitted to the Consultant for review and acceptance.

Repair of steel plates or rolled shapes by welding at the producing mill is not permitted.

~~Where mill test certificates originate from a mill outside Canada or the United States of America, the Contractor shall have the material tested and the mill test certificate verified by a Canadian laboratory. This laboratory shall be certified by an organization accredited by the Standards Council of Canada to comply with the requirements of ISO/IEC 17025 for the specific tests or type of tests required by the material standard specified on the mill test certificate. The mill test certificates shall be stamped with the name of the Canadian laboratory and the signature of an authorized officer. It shall state that the material is in conformance with the specified Contract requirements.~~

#### ~~6.2.4.2~~ Bolts

Structural steel with a boron content exceeding 0.0008% will not be permitted.

6.2.4.2 Bolts

All bolts shall conform to American Society for Testing and Materials (ASTM) Standard F3125 Grade A325 ~~or shall meet property class 8.8 of the Industrial Fasteners Institute for metric high strength structural bolts. The/A325M heavy hex style.~~ Nuts shall be heavy hex style and shall conform to ASTM A563 ~~and harden/A563M. Hardened~~ washers shall conform to ASTM F436. ~~Metric bolts/F436M.~~

~~Rotational capacity testing and reporting shall be marked performed in accordance with ASTM F3125 and submitted to the symbol A325M Consultant for review and those of "weathering" steel shall have the A325M symbol underlined. Weathering steel nuts shall be marked with three circumferential lines or shall be marked with a symbol "3". Weathering steel washers shall be identified by a symbol "3". Certified mill test reports for the fastener material shall be provided.~~ acceptance.

~~For bolts supplied from a manufacturer outside Canada or the United States of America, the above information shall be verified by a Canadian testing laboratory as outlined in clause 6.2.4.1~~

6.2.4.2.6.2.4.3 6.2.4.3 Stud Shear Connectors

All stud shear connectors shall conform to the chemical requirements of ASTM Standard A108, Grades 1015, 1018 or 1020. In addition, they shall meet the mechanical properties specified in AWS D1.5, Table 7.1 for Type B studs. Certified mill test reports for the stud material shall be provided.

6.2.4.4 Stud shear connectors with a boron content exceeding 0.0008% will not be permitted. The boron content of stud shear connectors shall be tested and results included with mill test reports.

6.2.4.3.6.2.4.4 Bearings

Bearings shall be in accordance with Section 8, ~~of the Specifications for Bridge Construction.~~ Bearings.

6.2.5 ~~6.2.5~~ Welding6.2.5.1 ~~6.2.5.1~~ Filler Metals & Welding Processes

Low hydrogen filler, fluxes and low hydrogen welding practices shall be used throughout. The deposited weld metal shall provide strength, durability, impact toughness, and corrosion resistance equivalent to base metal. The low hydrogen covering and flux shall be protected and stored as specified by AWS Standard D1.5. ~~Flux cored welding or use of cored filler wires in the submerged arc process or shielding gas process are not considered as conforming to low hydrogen practice. These methods will not be permitted.~~

(a) All electrodes, electrode/flux combinations, and electrode/shielding gas combinations shall be CSA certified.

Only the following welding processes and associated consumables shall be used:

#### 6.2.5.1.1 Submerged Arc Welding (SAW)

~~Submerged arc welding process is allowed for all flat and horizontal position welds.~~ All flange and web ~~butt joints~~ groove welds shall be made by ~~an approved~~ semi or fully automatic submerged arc process. acceptable to the Department.

All web to flange fillet welds and all longitudinal stiffener to web fillet welds shall be made by ~~an approved~~ fully automatic submerged arc process acceptable to the Department.

The Submerged arc ~~process~~ welding process may be used for flat and horizontal position welds.

~~(b)~~ All electrodes and fluxes shall conform to the diffusible hydrogen requirements of AWS D1.5 filler metal hydrogen designator H8 or lower. Use of cored filler wires in the submerged arc welding process or shielding gas process will not be permitted.

#### 6.2.5.1.2 Shielded Metal Arc Welding (SMAW)

Shielded metal arc welding ~~is allowed~~ may be used for girder vertical stiffener to flange fillet welds ~~and for miscellaneous components such as,~~ deck drains, bridge bearings, deck joint assemblies, pier nose plates, and buffer angles.

~~(c)~~ All electrodes and fluxes shall conform to the diffusible hydrogen requirements of AWS D1.5 filler metal hydrogen designator H4.

#### 6.2.5.1.3 Metal Core Arc Welding (MCAW)

Metal core welding ~~process utilizing low hydrogen consumables with AWS designation of H4 is allowed~~ may be used for vertical stiffeners and horizontal gussets of the girders and miscellaneous components such as deck drains, bridge bearings, deck joint assemblies, pier nose plates, hand rails, bridge rails and buffer angles.

All electrodes shall conform to the diffusible hydrogen requirements of AWS D1.5 filler metal hydrogen designator H4

Field ~~application of welding using the~~ metal core arc welding process is not ~~allowed~~ permitted.

#### 6.2.5.2 ~~6.2.5.2~~ Cleaning Prior to Welding

Weld areas must be clean, free of mill scale, dirt, grease, and other contaminants prior to welding. For multi-pass welds, previously deposited weld metal shall also be thoroughly cleaned prior to depositing subsequent passes.

### 6.2.5.3 ~~6.2.5.3~~—Tack and Temporary Welds

Tack and temporary welds shall not be allowed unless they are to be incorporated in the final weld. Tack welds, where allowed, shall be of a minimum length of four times the nominal size of the weld and length shall not exceed 15 times the weld size, and shall be subject to the same quality requirements as the final welds. Tack welds shall be sufficiently ground -out prior to final weld in order to obtain a uniform weld bead. Cracked tack welds shall be completely removed prior to re-welding.

### 6.2.5.4 ~~6.2.5.4~~—Run-off Tabs

Run-off tabs shall be used at the ends of all welds that terminate at the edge of a member. ~~The tab~~The thickness and shape of the tabs shall replicate the joint detail being welded and shall be a minimum of 100 mm long unless greater length is required for satisfactory work. They shall be tack welded only to that portion of the material that will not remain a part of the structure, or where the tack will be welded over and fused into the final joint. After welding, the tabs are to be removed by flame cutting, not by breaking off.

### ~~6.2.5.5~~—Preheat

#### ~~6.2.5.5~~ Preheat and Interpass Temperatures

Preheat and interpass temperature requirements shall be ~~performed and maintained~~ as per AWS D1.5, except that all welds on girder flanges shall be ~~preheated~~preheated to a minimum temperature of 100 °C unless a higher ~~temperature~~temperature is required by AWS D1.5 for the flange thickness. The preheat temperature of the web to flange joint shall be measured 75 mm from the point of welding on the side of the flange opposite to the side where the weld is being applied.

### ~~6.2.5.5~~~~6.2.5.6~~ ~~6.2.5.6~~—Welding at Stiffener Ends

To prevent notching effects, stiffeners and attachments fillet ~~welded~~welded to structural members shall have the fillet welds terminate 10 mm short of edges.

### ~~6.2.5.6~~~~6.2.5.7~~ ~~6.2.5.7~~—Submission ~~for~~of Repair Procedures

The Contractor shall submit repair procedures for damaged base metal and unsatisfactory weldments, ~~prepared to the Consultant and the Department for review and acceptance prior to commencement of the repair work.~~ The repair procedures shall be signed and sealed by an experienced welding engineer registered as a Professional Engineer registered in the Province of Alberta ~~for review by the Department and Consultant prior to repair work commencing.~~

~~6.2.5.7~~ ~~6.2.5.8~~ **6.2.5.8** Arc Strikes

Arc strikes will not be permitted. In the event of an isolated accidental arc ~~strikes, the Contractor shall submit to the Department and Consultant for review~~ strike, a ~~proposed~~ repair procedure ~~shall be submitted in accordance with Subsection 6.2.5.7, Submission of Repair Procedures.~~ At a minimum, the repair procedure shall include the complete grinding out of the crater produced by the arc strike. The repair procedure shall also include MPI and hardness testing of the affected area. Hardness of the repaired area shall conform to the requirements of Subsection 6.2.8.11, Hardness Tests. These areas will be examined by the Consultant to ensure complete removal of the metal in the affected area.

~~6.2.5.8~~ ~~6.2.5.9~~ **6.2.5.9** Grinding of Welds

Flange ~~butt~~ groove welds shall be ground flush or to a specified slope on both sides. Web ~~butt~~ groove welds which are sufficiently smooth with a neat appearance and uniform profile as determined by the Consultant will not require grinding. Fillet welds shall be continuous with uniform size and profile. ~~At~~ Locations which are not ~~conforming~~ conforming to acceptable profile shall be ground to the proper profile without ~~substantial removal~~ damaging of the base metal. Grinding shall be smooth and parallel to the line of stress. Caution shall be exercised to prevent over grinding. Over grinding that, results in reduced thickness of the base metal or size of the weld shall not be permitted. Acceptability of the welds without grinding will be determined by the Consultant.

~~6.2.5.9~~ ~~6.2.5.10~~ **6.2.5.10** Plug and Slot Welds

Plug welds or slot welds shall not be permitted.

~~6.2.5.10~~ ~~6.2.5.11~~ **6.2.5.11** Welding ~~of~~ Girder Flanges and Webs

With the exception of longitudinal web to flange welds, all stiffeners, gusset plates, or any other detail material welded to girder flanges shall be a minimum of 300 mm from ~~the flange butt welds~~ any flange groove weld. Stud shear connectors shall not be installed within 50 mm of any flange groove weld.

With the exception of longitudinal web to flange welds and longitudinal stiffeners to web welds, all stiffeners, gusset plate, or any other detail material welded to girder webs shall be a minimum of 300 mm from ~~the~~ any web ~~butt welds~~ groove weld.

**6.2.6** ~~6.2.6~~ Fabrication

Fabrication shall be performed in a fully enclosed area which is adequately heated. The shop temperature shall be at least 10 °C.

#### 6.2.6.1 ~~6.2.6.1~~—Heat Number Transfer

As the plate is subdivided for webs and flanges, all heat numbers shall be transferred to each individual section. The numbers shall remain legible until such time as the material location in the final assembly has been recorded. Mill identification numbers stamped into the material shall be removed by grinding at an appropriate time.

#### 6.2.6.2 ~~6.2.6.2~~—Marking Systems

Methods and medium of marking and the location of marks shall be accepted by the Consultant. Steel stamps shall not be used. The only exception is the match marking of splice plates, which may be steel, stamped using low stress stamps. The stamps and specific locations of such stamps must be shown on the shop drawings and accepted by the Consultant.

#### 6.2.6.3 ~~6.2.6.3~~—Cutting of Plate

All plate material for main members, splice plates and any plate material welded to the main member shall be flame cut using an automatic cutting machine.

#### 6.2.6.4 ~~6.2.6.4~~—Flange Stripping

All flange material shall be cut so that the direction of the applied stress will be parallel to the direction of the plate rolling.

#### 6.2.6.5 ~~6.2.6.5~~—Flame Cut Edges

The flame cut edges of girder flanges shall have a maximum Brinell hardness ~~as stated by section 6.2.8.10 in accordance with Subsection 6.2.8.11, Hardness Tests.~~ The surface roughness of the flame cut edge shall not be greater than ANSI B46.1 500 µin. (12.5 µm) and be such that as to allow Brinell hardness testing without spot grinding. The Consultant will perform Brinell hardness tests at random on the as is flame cut edge. Tests will be taken at a minimum of three locations for each cut edge of the plate (at each end and mid-point along length of cut edge) before any flange butt splices are completed. If the hardness exceeds the requirements, the Contractor shall submit for review, his procedures for repairing the edges to meet the requirements. The surface of flame cut apertures shall be finished by grinding and shall be free of nicks and gouges.

The Contractor shall report all blow backs or signs of lamination ~~observed or any other discontinuity detected on plate cut edges for tension members~~ during the cutting of the material. In case of plate lamination, the Contractor at his expense shall arrange for a CAN/CSA 178.1 certified NDT company to determine the extent. The ultrasonic testing technician shall be certified to Level II of CGSB. The damage report and repair procedure shall be prepared by a Professional Engineer registered in the Province of Alberta indicating the material is suitable for the girder fabrication and shall be forwarded to the Consultant for review and acceptance of the material.



6.2.6.6 ~~6.2.6.6~~—Additional Material Splices

Additional splices, other than those shown on the shop drawings, will require review and acceptance of the Department and Consultant. The Contractor shall bear the cost of inspection of these splices.

6.2.6.7 ~~6.2.6.7~~—Vertical Alignment

The structure shall be fabricated to conform to the requirements of the deflection and vertical curve, as noted on the Drawings. For rolled shapes, advantage shall be taken of mill camber that may be inherent in the material.

6.2.6.8 ~~6.2.6.8~~—Shop Assembly6.2.6.8.1 ~~(a)~~—Plate Girders

The Work shall conform to the submitted sequence outlined in Subsection 6.2.3.4, Proposed Fabrication Sequence and Equipment and this Subsection.

Shop assembly of girders shall be by the progressive assembly method according to AASHTO LRFD Bridge Construction Specifications, except that only two, instead of three, sections need to be assembled.

~~The detailed method of assembly, including points of support, dimensional checks, method of trimming to length, drilling and marking of splices, shall be to the procedure submitted for review by the Consultant as per section 6.2.3.4.~~ Each individual girder section shall meet the camber requirements for that particular length, with the splices between these sections falling on the theoretical camber line for the entire span. Correction for variation in flange thickness must be ~~considered~~considered. When the camber of the girder fails to meet the required tolerance, the Contractor shall submit a proposed method of repair for review and acceptance by the Consultant. ~~The and the Department.~~ Adjustment for camber will not be allowed without the prior review and acceptance of the procedure and supervision of the repairs by the Consultant and the Department. The camber of each individual girder section must be known for the next two girder sections in the girder line prior to shop assembly of any particular girder section. This is to allow the Consultant to ~~call for~~determine the best fit line to reduce the effect of any camber differences should it be deemed necessary. Camber for plate girders will be measured on the top of the top flange. The camber of plate girders shall be measured in the “no load” condition.

6.2.6.8.2 ~~(b)~~—Box Girders

The progressive shop assembly for box girders shall be as per ~~section 6.2.6.8(a), Subsection 6.2.6.8.1, Plate Girders, with additional box girder specific~~ items as described in this ~~section are specific to box girders~~subsection.

The camber of box girders shall be measured on the top of the top flange, and each top flange of a box shall individually meet the required camber. Girder sections assembled for splicing shall be supported within 2 m of the end of each section. Girder sections shall be supported in such a manner as to provide the correct angular relationship at the splice between girder sections while the splices are being reamed or ~~drilled~~drilled. Shop drawings shall clearly indicate the expected dead load deflection of each section and the elevations of the sections while supported for the drilling or reaming of each splice.

#### 6.2.6.8.3 ~~(e)~~—Drilling

All splices shall be drilled from solid material while assembled or shall be ~~subpunched~~sub-punched or sub-drilled and then reamed to full size while in the shop assembly position. No reaming shall take place until acceptance of the assembly has been obtained from the Consultant.

#### 6.2.6.9 ~~6.2.6.9~~—Splice Plates

After shop assembly, splice plates and girders shall be clearly match marked to assure proper orientation and location of splice material for erection. All holes shall align with holes in the attached member. Splice plates shall then be removed, de-burred, solvent cleaned, to remove all oil and sandblasted to remove all mill scale, in order to provide a suitable faying surface: acceptable to the Consultant. These plates shall then be securely ship-bolted to the girders. The match marking system shall be shown on the shop drawings.

#### 6.2.6.10 ~~6.2.6.10~~—Bolt Holes

Clause 11.4.8 of AASHTO LRFD Bridge Construction Specifications shall apply except that all bolt holes in load carrying segments of main members and any material welded to main members shall be drilled full size or ~~subpunched 5 mm smaller and reamed to full size. Punching of full size holes for secondary members such as bracings which are not welded to main member is allowed for material less than 16 mm thick. All holes in girder splices shall be circular and perpendicular to the member and shall be deburred inside and outside to ensure a proper faying surface.~~sub-punched 5 mm smaller and reamed to full size.

~~6.2.6.11—Punching of full size holes for secondary members such as bracings, which are not welded to main member will only be permitted for material less than 16 mm thick. Diaphragm bracing members for kinked or curved girder bridges are considered primary structural members and therefore punching of full size holes will not be permitted.~~

~~Holes in girder splices and structural members shall be circular and perpendicular to the member. Cutting of slotted holes shall be done by plasma arc cutting. Holes shall be deburred inside and outside and free of nicks and gouges.~~

#### 6.2.6.11 Dimensional Tolerances

Normal tolerance for structural steel fabrication and fitting ~~between~~between hole groups will be  $\pm 3$  mm unless specified otherwise. The dimensional tolerances for structural members shall be within the AWS Standard D1.5, Section 3.5, except as otherwise noted below:

6.2.6.11.1 ~~(a)~~ Combined Warpage &and Tilt

Combined warpage and tilt of flange at any cross section of welded I-shape beams or girders shall be determined by measuring the offset at the toe of the flange from a line normal to the plane of the web through the intersection of the centerline of the web with the outside surface of the flange plate. This offset shall not exceed  $1/200$  of the total width of the flange or 3 mm whichever is greater at bolted splice location. Bolted splices of main stress carrying members shall have parallel planes and the surfaces shall be in full contact without any gap.

6.2.6.11.2 ~~(b)~~ Girder Camber

Camber of beams and girders shall be uniform, true and accurate to the centreline of the top flange. Permissible variation in camber shall be within  $\pm (0.2L_t + 3)$  mm; where  $L_t$  is the test length in metres. This applies to fabricated pieces only, prior to shop assembly. During shop assembly, splice points shall be located on the theoretical camber line or at a specified amount from the line should the Consultant choose to correct for shop camber deviations.

Where field splices are eliminated by combining girder segments into longer girder lengths, the cambers of the girders at the eliminated splice points shall be within  $\pm 3$  mm.

6.2.6.11.3 ~~(c)~~ Box Girders

Tolerances for box girder camber, sweep and depth shall be measured relative to two imaginary surfaces: a vertical plane passing through the centre line of the girder, and a surface located at the theoretical underside of the top flanges following the theoretical camber of the girder.

6.2.6.11.4 ~~(d)~~ Splices

Fill plates shall not be permitted at main girder field splices unless specified. The tolerance for girder depth or box girder geometry shall be as specified by AWS D1.5, except that the difference between similar dimensions of the adjoining sections being spliced shall not exceed  $\pm 3$  mm.

6.2.6.11.5 (e) Fitted Splice Gap Between Adjacent Girder Ends

At field splice locations, the gap between adjacent girder ends shall be 10 mm  $\pm$  5 mm.

~~6.2.6.11.5~~ 6.2.6.11.6 Stiffeners

The bearing ends of bearing and jacking stiffeners shall be flush and square with the web and shall have at least 75% of this area in contact with the flanges ~~whereas~~. Fitted stiffeners may have a gap of up to 1 mm between stiffener and flange.

~~6.2.6.11.6~~ 6.2.6.11.7 ~~(f)~~ Facing of Flanges

Surfaces of flanges which are in contact with bearing sole plates shall have a flatness tolerance of  $0.001 \times$  bearing dimension.

#### ~~6.2.6.11.7~~ 6.2.6.11.8 Bearing to Bearing Dimension

Bearing to bearing distance is a set dimension and therefore has no tolerance.

#### ~~(h) Deck Joint Assemblies~~

~~Deck joint assemblies shall be assembled for inspection in a relaxed condition with erection angles removed. Tolerances for straightness shall be considered over the length of the assembly between the crown and gutter line both before and after galvanizing. Deviation from straightness in a vertical plane shall not exceed  $\pm 6$  mm. Horizontal sweep or variations in gap setting shall not be greater than 3 mm.~~

#### 6.2.6.12 ~~6.2.6.12~~—Flange Corner Chamfer

Corners of all flanges shall be ground to a 2 mm chamfer. Corners of ~~stiffeners,~~ structural sections ~~and, plates, and outside corners of stiffeners~~ shall be ground to a 1 mm chamfer.

#### 6.2.6.13 ~~6.2.6.13~~—Milling ~~Stiffener~~ Tolerances

~~Tolerance for milled to bear~~The bearing ends of bearing and jacking stiffeners shall be ~~0.05 mm square and flush~~ with the web and shall have at least 75% of the area in ~~bearing contact with the flanges. The remaining 25% of the area may have a gap of up to 0.05 mm. Fitted stiffeners may have a gap of 1 mm between stiffener and flange.~~

#### 6.2.6.14 ~~6.2.6.14~~—Web Panning

The maximum variation from flatness for webs shall be  $0.01d$  where  $d$  is the least dimension of the panel formed by the girder flanges and/or stiffeners. Should the panning in one panel convex and the panning in the adjacent panel concave then the sum of the panning in the two adjacent sections shall not exceed that allowed for one panel. Localized deformation in the web shall not exceed 3 mm in 1 m.

#### 6.2.6.15 ~~6.2.6.15~~—Field Weld Preparation

All material to be field welded shall be prepared in the shop. Field welding shall be performed in accordance with Section 13, Miscellaneous Iron.

#### 6.2.6.16 ~~6.2.6.16~~—Flame Straightening and Heat Curving

Flame straightening and heat curving shall not be performed on any material or member without a written request to the Department and the Consultant. The Contractor shall submit a procedure developed by a Professional Engineer stating location, temperatures and cooling rates, to the Department and the Consultant for review. Straightening or heat curving shall only be performed in the presence of the Consultant.

6.2.6.17 ~~6.2.6.17~~—Stress Relieving

When stress relieving is specified, it shall be performed in ~~accordance~~accordance with AWS D1.5. Copies of the furnace charts shall be supplied to the Consultant.

6.2.6.18 ~~6.2.6.18~~—Handling and Storage

All lifting and handling shall be done using devices that do not mark, damage, or distort the assemblies or members in any way. Girders shall be stored upright, supported on sufficient skids and safely shored to maintain the proper section without buckling, twisting or in any way damaging or misaligning the material.

6.2.7 ~~6.2.7~~ Surface Preparation and Coating6.2.7.1 ~~6.2.7.1~~—Abrasive Blast Cleaning

Unless otherwise noted, all steel components shall be abrasive blast cleaned after fabrication in accordance with the Society for Protective Coating Standard (SSPC) No. SP6. ~~Essentially this is a surface from which all oil, grease, dirt, rust, foreign matter, mill scale and old paint have been completely removed except for slight shadows, streaks or discolorations caused by rust stain or mill scale oxide binder.~~ The exterior face of the exterior girders shall be uniform in appearance as determined by the Consultant.

~~6.2.7.2~~—~~Prime Coating~~~~6.2.7.2~~ Coating

At all bearing locations, ~~girder an organic zinc epoxy primer shall be applied to the underside of bottom flanges shall be prime coated in contact with the bearing sole plate. The primer shall extend the full width of the flange and 15 mm beyond the projected contact surface of the bearing sole plate in the longitudinal direction.~~

~~At all around (deck joint locations a complete SF2, SF3 or SF4 approved bridge coating system from the Department's Product List shall be applied to the bottom flange surfaces (underside, top and edges)), with the exception that the faying surface of the underside of bottom flange in contact with the bearing sole plate shall only receive the organic zinc epoxy primer. The coating system shall extend longitudinally from the girder end to a distance 100 mm beyond the bearing dimension. In addition, at locations where the abutments are incorporating deck joints, the prime coat shall be extended up the sole plate or 100 mm beyond the jacking stiffener, whichever distance is greater. The selected SF2, SF3 or SF4 coating system shall be applied to the full height of the bridge webs (both sides of web, and including any applicable bearing/jacking stiffeners) and to the underside of the top flange flanges. The prime coat longitudinal extent of this coating shall be an approved organic zinc epoxy primer that has been qualified by test the same as described above. Faying surfaces of bolted connections shall only receive the organic zinc epoxy primer.~~

~~Any of the portions of the girder noted above that will be encased in cast in place concrete shall be left in the bare steel condition with no coating applied.~~

The approved organic zinc epoxy primer shall meet the requirements of a Class B coating, in accordance with the “Testing Method to Determine the Slip Coefficient for Coatings Used in Bolted Joints” as described in Appendix A of the Research Council on Structural Connections “Specification for Structural Joints Using High-Strength Bolts”. ~~The coating supplier shall provide~~ A certificate stating of compliance with this specification for the coating proposed shall be provided to the Consultant Department for review and acceptance prior to application. The top coat colour shall conform to US Federal Standard 595C colour FS30045.

### ~~6.2.7.26.2.7.3~~ 6.2.7.3 Galvanizing

The fabricator shall provide a smooth finish on all edges and surfaces, and remove all weld spatters, and all welding flux residue from the steel components prior to galvanizing.

Factors contributing to galvanization-induced cracking shall be minimized. Galvanizing shall be by the hot dip method, after fabrication, in accordance with the current edition of ASTM A123/A123M Standard Specification for Zinc (Hot-Dip Galvanized) Coatings on Iron and Steel Products and ASTM F2329 Standard Specification for Zinc Coating Hot-Dip Requirements for Application to Carbon and Alloy Steel Bolts, Screws, Washers, Nuts, and Special Threaded Fasteners ~~with additions and exceptions as described~~ modified in this specification.

The ~~fabricator cleaning and pickling procedure of high strength ASTM A193 Grade B7 anchor rods shall provide a smooth finish on all edges and surfaces, and remove all weld spatter and all welding flux residue from the steel components~~ be modified as follows prior to hot-dip galvanizing:

- Repair of galvanizing shall only be done if bare areas are infrequent, small, and suitable for repair. A detailed repair Brush blast to remove mill scale and oil after threading ends;
- Flash pickle up to 5 minutes; and
- Quick dry prior to hot-dip galvanizing (not stored in flux or acid rinse).

The modified anchor rod cleaning and pickling procedure shall be submitted for review prior to its use. ~~It should be noted that repairs may require complete removal~~ completed in the presence of the galvanized coating and re- Consultant prior to hot-dip galvanizing.

Repair of galvanizing shall be completed in compliance with ~~accordance~~ ASTM A780, Method A3 “Metallizing”. ~~However repair for” and will only be permitted when the repair areas are small and infrequent as determined by the Consultant. Repair areas not exceeding less than 100 mm<sup>2</sup> in area may be done~~ completed in accordance with ASTM A780, Method A1 “Repair Using Zinc-Based Alloy”. The thickness of the coating for both methods shall be 180 µm, and the repair tested for adhesion. A detailed repair procedure shall be submitted for review and acceptance by the Consultant prior to commencement of the work. Repairs may require complete removal of the galvanized coating and re-galvanizing. The finished appearance shall be similar to the adjacent galvanizing— as determined by the Consultant ~~will determine the acceptability of repaired areas.~~

### ~~6.2.8~~ Testing and Inspection

#### ~~6.2.8.1~~ Access

Galvanized material shall be stacked or bundled and stored to prevent wet storage stain as per the American Hot Dip Galvanizers Association (AHDGA) publication "Wet Storage Stain". Any evidence of wet storage stain shall be removed to the satisfaction of the Consultant.

Galvanized contact surfaces of bolted connections shall be hand wire brushed to a Class A slip coefficient surface condition. Slip coefficient surface conditions shall meet the requirements of Table 10.9 of CSA S6.

### 6.2.8 Testing and Inspection

#### 6.2.8.1 Access

The Contractor shall provide full facilities for the inspection of ~~material and workmanship. Free~~Work. ~~The Consultant shall have full~~ access ~~shall be allowed to the Consultant~~ to all parts of the ~~works~~Work at all times. When required by the Consultant, the Contractor shall provide needed manpower for assistance in checking layout and performing inspection duties.

#### ~~6.2.7.36.2.8.2~~ 6.2.8.2 Responsibility

It is the Contractor's responsibility to ensure that the ~~supply of material and the fabrication are~~ Work is completed in accordance with the Contract requirements. ~~The~~Any inspection and/or testing ~~completed~~ by the Consultant, review and acceptance by the Consultant, shall not be ~~deemed to relieve~~considered as relieving the Contractor of ~~any of his/her obligation~~the responsibility for completing the Work in accordance with the Contract.

#### ~~6.2.7.46.2.8.3~~ 6.2.8.3 Testing by the Consultant

The visual, radiographic, ultrasonic, magnetic particle, dye penetrant, hardness testing, and ~~any other inspection that may be specified or required~~stud shear connector testing will be performed by the Consultant or ~~by his~~ designated testing agencies ~~at the Consultant's expense.~~ The Consultant may complete additional testing and inspection at his discretion and the Contractor shall provide full access to the Work as required by the Consultant.

The Contractor shall be responsible for all ~~travel, boarding and lodging~~ costs incurred by the Consultant to attend the pre-fabrication meeting and to inspect bridge girders, cover plated v-seal deck joints, and finger plate deck joints being fabricated outside the Province of Alberta. The ~~cost~~Contractor shall also includebe responsible for at the cost of the Department's representative to attend the ~~prejob~~pre-fabrication meeting and three additional trips to ~~oversee the inspection of girders during the course of fabrication. This requirement for attending the prejob meeting will also apply for the review the fabrication.~~ For the cover plated v-seal and finger plate deck joint; ~~however~~joints the number of additional trip requirement will be reduced to onetrips required for the Department's representative will be reduced to one.

#### ~~6.2.7.56.2.8.4~~ 6.2.8.4 Testing by the Contractor

The ~~exception to section 6.2.8.3 is that additional inspection required by the Consultant shall be paid by the Contractor for the following conditions:~~

- ~~Any repair work during the course of cutting, welding, fabrication or handling;~~
- ~~Evaluation of any defective material by the Consultant.~~
- ~~Additional unspecified material splices.~~

~~Any test Contractor's testing and inspection records made by the fabricating shop in the course of normal quality control shall be open to for examination by the Consultant for inspection upon request.~~

#### 6.2.8.5 Inspection Station

~~To insure that each stage of inspection is performed in an orderly manner, during the fabrication of major structures, Inspection Stations will be Testing, inspection and related costs incurred by the Consultant resulting from defective work or Contractor proposed connections and/or splices not specified on the Drawings shall be paid for by the Contractor.~~

#### 6.2.8.5 Witness Points

~~Inspection stations shall be set up at specific points. Sub-assemblies of the work will then be during the course of fabrication for the Consultant to complete the required testing and/or inspection. At each witness point the Work shall be checked by the Contractor, confirmed and tested and inspected by the Consultant, and all deficiencies shall be corrected, to the full satisfaction of the Consultant prior to the work being sent to the next stages sequence of fabrication.~~

~~Typical check Witness points for a plate girder are and box girders shall be:~~

- Flange plates prepared;
- Web plates prepared;
- Web to flange welds completed prior to fitting any stiffeners;
- Completion of all welding prior to splicing;
- Splice set-up prior to drilling;
- Surface preparation and coating; and
- Final inspection and clearance to ship.

#### 6.2.8.6 Non-destructive Methods of Examination

~~6.2.8.6 The methods of non-destructive examination shall be Testing~~

~~Non-destructive testing (NDT) is to be completed in accordance with the following standards:~~

- ~~— Radiography - AWS Standard D1.5;~~
- ~~— Ultrasonic - AWS Standard D1.5;~~
- ~~— Magnetic Particle - ASTM Standard E-709;~~
- ~~— Dye-Penetrant - ASTM Standard E-165; and~~
- ~~— Hardness tests - ASTM Standard E-10310.~~



~~6.2.7.6~~ ~~6.2.8.7~~ 6.2.8.7 Radiographic Inspection Schedule

~~Unless otherwise noted,~~ Radiographic inspection of welded plate steel girders will be performed in accordance with the following schedule:

- ~~(a)~~ (a)—100% of all tension flange and stress reversal butt groove welds, all stiffener butt groove welds and all diaphragm butt groove welds, and any groove welded attachments to flange plates.;
- A minimum of 25% of all other flange butt groove welds randomly selected by the Consultant for each structure.;

~~(b) All web butt welds in tension and stress reversal zones plus additional 300 mm of web butt weld in compression zone at the end of the web.~~

- 100% of all web groove welds; and
- If defects are found during testing, additional area testing will be ~~tested to ensure the quality of welds completed.~~

~~6.2.8.8~~ 6.2.8.8 Radiographic Inspection For steel members 65mm thick and thicker, 25% of Miscellaneous Material

~~Unless otherwise noted, the welds will also be inspected by ultrasonic in addition to radiographic inspection of miscellaneous material will be performed by the Contractor in accordance with the following schedule: requirements.~~

~~(a) 100% of all tension members.~~

- ~~(b) 50% of all other members.~~

The radiographic inspection report and the film shall be provided submitted to the Consultant for review and acceptance within 48 hours of the inspection completion ~~of inspection~~.

~~6.2.8.8~~ ~~6.2.8.9~~ 6.2.8.8 6.2.8.9 Radiographic Inspection of Welds for Miscellaneous Material

Radiographic inspection of materials other than welded steel girders shall be performed by the Contractor in accordance with the following schedule:

- 100% of all tension members; and
- 50% of all other members.

For steel members 65mm thick and thicker, 25% of the welds shall also be inspected by ultrasonic to supplement the Radiographic inspection

The radiographic inspection report and the film shall be submitted to the Consultant for review and acceptance within 48 hours of inspection completion.

~~6.2.7.7~~6.2.8.9 Magnetic Particle Inspection Schedule

~~Unless otherwise noted,~~ Magnetic particle inspection of welded plate and box girders will be performed in accordance with the following schedule:

- ~~(a)~~ — 50% of the web to flange welds or any fillet welds placed on flange plates. The tests shall be in 1.5 m lengths including a 1.5 m length at each end of each web to flange weld;
- ~~(b)~~ — ~~10~~20% of the ~~web to~~ stiffener to web welds;
- ~~(c)~~ — 100% of the stiffener and diaphragm connector plate to flange welds;
- 100% of the bearing sole plate to flange welds;
- 20% of the diaphragm connector plate welds to web;
- 100% of all manual (SMAW) welds; and
- ~~6.2.8.10~~ — 25% of all fillet welds for other bridge components.

~~6.2.7.8~~6.2.8.10 Dye Penetrant Inspection

Dye penetrant inspection will be performed in areas of the structure deemed necessary by the Consultant. In particular, the ends of the weld metal of all flange ~~buttgroove~~ welds after the removal of runoff tabs will be inspected using this method. Dye penetrant inspection will be done for all flange plate edges regardless of whether or not the plates are cut before or after welding. Defects discovered by this inspection shall be repaired by the Contractor, and the suspect area re-inspected.

~~6.2.7.9~~6.2.8.11 ~~6.2.8.11~~ Hardness Tests

Hardness tests will be performed ~~by the Consultant~~ on ~~the~~ flame cut edges of ~~the~~ girder flange plates prior to assembly. A minimum of three readings for each cut edge of the plate (at each end and mid-point along length of cut edge) will be taken.

Unless otherwise noted, the hardness of the flame cut edges shall not exceed a maximum Brinell as noted below:

- ~~(a)~~ — For carbon steels with a yield strength less than and including 300 MPa, the maximum Brinell shall be 200 BHN; and
- ~~(b)~~ — For carbon steels with yield strengths greater than 300 MPa, the maximum Brinell shall be 220 BHN.

Remedial work to the edges which exceed the specified hardness shall be performed and re-inspected prior to assembly.

~~6.2.7.106.2.8.12~~ 6.2.8.12 — Testing Stud Shear Connectors

Stud shear connectors and their associated bend testing shall meet all requirements as outlined by AWS D1.5. When bend testing, the studs ~~shall~~will be bent towards the centre of the girder. All the remaining studs ~~shall~~will be tested by striking with a hammer. A dull sound indicates incomplete fusion and a bend test will then be required for a potentially defective stud to ensure the integrity.

~~6.2.7.116.2.8.13~~ 6.2.8.13 — Inspection Schedules

The Contractor shall ~~ensure that adequate~~provide notice of scheduled inspection requirements ~~be given to the Consultant and inspection agencies, and that access to the work is their representative(s). The amount of notice required will be provided at all times. to~~ the Contractor ~~shall provide~~by the Consultant ~~with his sequence of fabrication in order that the inspection program can be properly integrated and agreed to, prior to commencement of fabrication.~~

~~6.2.8.14~~ Strip Seal Deck Joint

~~The installation of strip seal shall be tested by the Contractor in the presence of the Consultant for leakage. The failed areas shall be corrected and retested. The defective and/or torn seal shall be replaced at the Contractor's expense. their representative(s).~~

~~The Contractor and the Strip Seal Deck Joint Supplier shall jointly provide warranty for the satisfactory performance of the deck joint assemblies for a period of five years. The joint warranty shall be provided to the Consultant prior to the issuance of the Construction Completion Certificate.~~

~~The deck joint warranty shall provide for the replacement and/or repair of the deck joint assemblies, including all necessary traffic control at no cost to the Department, should unsatisfactory performance occur during the five year period.~~

~~6.2.7.126.2.8.14~~ 6.2.8.15 — Notification to Ship

The Contractor shall notify the Consultant 4872 hours prior to shipment to facilitate ~~final~~ inspection and acceptance of the ~~materials. Material~~structural steel. Structural steel shall not be shipped until it has been reviewed and accepted by the Consultant. Review and acceptance of structural steel at the fabrication facility by the Consultant will not relieve the Contractor of his full responsibility to meet the requirements of these specifications.

Structural steel that has not been inspected ~~in~~at the fabrication ~~plant~~facility will not be paid for until such material has been inspected, reviewed and accepted by the Consultant. The Contractor ~~may~~shall be ~~charged with responsible for all expenses~~costs incurred ~~by the Consultant~~ for inspection of the ~~material~~structural steel not inspected at the ~~site~~fabrication facility.

#### 6.2.8.15 ~~6.3~~ Structural Steel Fabrication Outside of Canada

All testing and inspection requirements specified in Subsection 6.2.8, Testing and Inspection, shall be completed at the fabrication facility and all costs incurred by the Consultant and their designated testing agencies, and the Department shall be paid for by the Contractor.

All components fabricated outside of Canada shall be shipped to a shop located in Canada that is certified by CWB in accordance with CSA W47.1 to Division 1 and by CISC in the category of steel bridges for re-inspection and testing. The components shall be in a condition that facilitates all re-inspection and testing requirements. The re-inspection and testing at the Canadian shop shall be completed in accordance with Subsection 6.2.8, Testing and Inspection. The Contractor shall also arrange for inspection by a CSA 178.2 Level III certified welding inspector accredited with W47.1/W59 to inspect:

- All components to ensure that they were undamaged during transportation; and
- Shop assembly in accordance with Subsection 6.2.6.8, Shop Assembly.

Components shall not be shipped from the Canadian shop until all requirements have been met and the Work has been reviewed and accepted by the Consultant.

The Contractor shall be responsible for all re-inspection and testing costs, including all cost incurred by the Consultant and the Department.

The Contractor shall have no claim against the Department resulting from delays caused by these requirements.

#### 6.2.8.16 Finger Plate and Cover Plated V-Seal Deck Joint Assemblies

Specified tolerances of finger plate and cover plated v-seal deck joints shall be measured and recorded at a minimum of 4 inspection hold points. The minimum 4 inspection hold points shall be:

- (1) Prior to shipment from the fabrication facility. Measurement of tolerances at inspection hold point 1 shall occur with the deck joint fully assembled in a relaxed condition without shipping and erection angles installed and at the -5°C and +15°C 'X' gap settings. For cover plated v-seal deck joints, the cover plates shall be installed with bolts tightened;
- (2) After installation of the deck joint into the blockout and prior to abutment side blockout concrete placement. Measurement of tolerances at inspection hold point 2 shall occur with the deck joint fully assembled, shipping angles and erection angles installed with bolts tightened;
- (3) After the abutment side blockout concrete has been placed, cured and developed a minimum compressive strength of 20 MPa, and prior to deck side blockout concrete placement. Measurement of tolerances at inspection hold point 3 shall occur with the deck joint fully assembled, shipping angles and erection angles installed with bolts tightened; and

(4) For finger plate deck joints: immediately after completion of curing of abutment side and deck side blockout concrete.

For cover plated v-seal deck joints: after completion of curing of abutment side and deck side blockout concrete, epoxy injection is complete, v-seals are installed, and cover plates are reinstalled with bolts tightened.

Measurement of tolerances at inspection hold point 4 shall occur with the deck joint fully assembled and supported by the concrete with shipping angles and erection angles removed.

Gap tolerances between finger plates, cover plates and support plates shall be in accordance with the applicable Standard Drawings.

If the specified tolerances are not met at each inspection hold point, the Contractor shall repair the deck joint such that all specified requirements are met. The Contractor shall prepare and submit a repair procedure to the Consultant and the Department for review and acceptance prior to commencement of any repair work.

The climatic conditions shall be recorded at the time of tolerance measurements at each inspection hold point.

The Contractor shall notify the Consultant that the deck joint meets the specified tolerances at each inspection hold point and is ready for inspection. The Consultant will then measure and record all tolerances at similar climatic conditions to those in which the Contractor took his initial tolerance measurements. Deck joints shall not be released from an inspection hold point until the Consultant's acceptance of the deck joint has been received in writing.

### **6.3 Structural Steel Erection**

The Contractor shall erect ~~the structural steel, remove any temporary construction and do all work required to complete the erection as shown on the Drawings, in accordance with the drawings and these specifications. No drilling and the Special Provisions of additional holes or any other modifications including field welding shall be made to the Contract. Structural steel elements other than deck joints. Lifting devices shall erection shall also include, but is not be welded~~ limited to the girders—following:

- Erecting and removal of temporary supporting structures;
- Removal of anchor rod void formwork;
- Installing deck joints; and
- Coating touch up.

The Contractor shall not erect the structural steel until the substructure concrete has been cured a minimum of three days and achieved a minimum of 80% of the 28 day specified concrete strength requirement. ~~Without restricting generality, erection includes:~~

~~—erecting of temporary supporting structures~~

~~— removing anchor bolt grout can lid~~

~~— erecting~~ Cranes shall be used for the handling and erection of structural steel girders.

~~— placing of expansion assemblies~~

~~— touching up painting as required~~

6.3.1— Lifting forces shall be vertical. Lifting devices shall not be welded to the girders or require the removal of any stud shear connectors for attachment to the girders. Drilling of additional holes or any other modifications, including field welding will not be permitted.

The Contractor shall maintain girder stability; location; and horizontal, vertical and longitudinal alignment at all times during construction.

Grout pads shall meet the requirements of Section 8, Bearings.

#### 6.3.1 Transportation, Handling and Storing Materials

~~Girders and beams~~ shall be transported with girder webs in the vertical position. ~~However these elements may be transported~~

If the Contractor proposes to transport the girders with webs in other positions provided:

a position other than vertical, the Contractor shall submit a girder transportation assessment to the Consultant for review and acceptance a minimum of two weeks prior to shipping from the fabrication facility. The girder transportation assessment shall be signed and sealed by a Professional Engineer registered in the Province of Alberta shall determine. Review comments provided by the Consultant and/or the Department shall be incorporated into the transportation assessment and resubmitted to the Consultant for review and acceptance prior to shipping from the fabrication facility. The Consultant's review and acceptance shall not be considered as relieving the Contractor of the responsibility for completing the Work in a manner that does not, in the opinion of the Consultant and Department, damage the girders. All costs associated with the transportation assessment will be considered incidental to the Work and no separate or additional payment will be made.

The transportation assessment, at a minimum, shall include design notes, drawings, rationale for the proposed transport position, and statement indicating the proposed method will not damage the girders. Design notes shall include evaluation of the static and dynamic forces and associated stresses during handling, transportation, and storage using a dynamic load allowance of 100%. ~~Computed~~The stresses shall be ~~according to CAN/in accordance with~~ CSA -S6, Clause 10.10, Beam and Girders, and the maximum cyclic stress range shall not exceed the constant amplitude fatigue threshold for the appropriate fatigue categories specified in ~~CAN/CSA-S6, Table 10.4. All the calculations and associated sketches, including reasons why the girders cannot be shipped with the webs in the vertical plane, shall be submitted by the Contractor to the Consultant for review two weeks prior to shipping. The calculations and sketches shall be signed and sealed by the Engineer who performed the analysis and includes a written statement that the proposed method will not damage the elements.~~CSA S6, Table 10.4, Fatigue life constants and constant amplitude threshold stress ranges

Structural steel shall be protected from dirt, road salts, slush or other contaminants during transportation, handling and storage.

Upon arrival at the site and prior to erection, the ~~elements shall be checked by the Contractor in the presence of the Consultant to ensure all tolerances are met., shall inspect materials for cleanliness and presence of damage.~~ The Contractor shall provide an adequate flat storage area and space between elements for the inspection. A detailed inspection report shall be provided to the Consultant for review and acceptance within three days of the inspection. Erection shall not commence until the detailed inspection report has been reviewed and accepted by the Consultant.

Structural steel that becomes contaminated with any dirt, road salts, slush or other contaminants, shall be cleaned and surfaces prepared to the satisfaction of the Consultant prior to erection or installation.

Any structural steel member damaged during transportation, handling, storing or erection shall be immediately reported to the Consultant and the Department ~~and the Consultant.~~ The Contractor shall provide an engineering assessment report and repair procedure prepared by a Professional Engineer registered in the Province of Alberta experienced in evaluation and inspection of damaged steel members. The assessment report and repair procedure shall be submitted to the Consultant and the Department for review and acceptance. The Consultant will also arrange to have an independent inspection and assessment performed on the damaged member by a Level III certified welding inspector as per CSA 178.2 accredited with W47.1/W59. The Contractor shall provide at least a minimum three working daydays' notice for the inspection and facilitate all the activities associated with the inspection. All costs associated with the independent inspection will be the responsibility of the Contractor.

Material to be stored shall be placed on timber blocking. It shall be kept clean, free from dirt, grease, and any other foreign matter and stored in a properly drained area. Handling and lifting devices shall not mark, damage, or distort members. Softeners shall be used where chains or other tie down devices are in direct contact with the steel members. Girders and beams shall be ~~placed upright and~~ shored, and stored in the vertical position. Long members, such as deck joint assemblies, buffer angles, columns and chords, shall be supported on timber blocking to prevent damage or distortion from deflection. Galvanized material shall be handled and stored ~~as per section~~ in accordance with Subsection 12.2.8, Handling and Storage.

### 6.3.2 ~~6.3.2~~ Bridge Girders

#### 6.3.2.1 ~~6.3.2.1~~ — Temporary Supporting Structures and Berms

The temporary supporting structures and berms shall be designed, constructed and maintained to safely support all loads.

Berms shall be constructed in a manner and of such materials that they will not be eroded by stream flow nor introduce silt into the ~~water. The Contractor shall prepare and submit drawings for the Consultant's review for temporary supporting structures and berms where applicable. Review of the Contractor's drawings shall not be considered as relieving the Contractor of any responsibility. All drawings submitted shall bear the seal of a Professional Engineer registered in Alberta~~ watercourse.

~~Temporary supporting structures and/or berms will not be permitted to remain in any stream channel during spring break-up or runoff periods, unless all necessary approvals have been obtained from pertinent agencies and prior written acceptance obtained from the Consultant.~~

~~Repair to any damage to property, such as earth fills and stream banks, resulting from the existence of berms, shall be the responsibility of the Contractor.~~

#### 6.3.2.2 ~~Review of Erection Procedure~~

The Contractor shall prepare and submit to the Consultant, for record purposes and for examination four copies of the detailed erection procedure four weeks in advance of the scheduled start of erection. ~~The erection procedure shall include all drawings and documents necessary to describe the following:~~

- ~~(a) Traffic Accommodation Strategy (TAS), as applicable.~~
- ~~(b) Access to work, earth berms and work bridges.~~
- ~~(c) Type and capacity of equipment. Cranes shall be used for handling and erecting structural steel girders.~~
- ~~(d) Sequence of operation including position of cranes, trucks with members.~~
- ~~(e) Position of cranes relative to substructure elements such as abutment backwalls, with that clearly indicate details of load distribution of wheels and outriggers.~~



~~(f) Lifting devices and lifting points.~~

~~(g) Details of temporary works, supporting structures drawings including proposed methods to be used to ensure the required splice elevations and structure shape prior to bolt torquing, method of providing temporary supports for stability, top of girder elevations at each bearing and each splice location where appropriate.~~

~~(h) Bolt tightening sequence.~~

~~(i) Grout Pad Construction. Refer to section 6.3.2.10 of these Specifications.~~

~~(j) Details of release of temporary supporting structures.~~

~~(k) Provide an "As-Constructed" detailed survey of the substructure showing the following:~~

- ~~— location and elevation of all bearing grout pad recesses including anchor bolt voids,~~
- ~~— shim height at each bearing location,~~
- ~~— top of girder elevations at each bearing and each splice location where appropriate.~~
- ~~— longitudinal measurements between centreline of bearings of all substructure elements.~~

~~The erection procedure shall bear the Seal of all temporary supporting structures and berms, sealed by a Professional Engineer registered in the Province of Alberta, who shall assume full responsibility to ensure that his erection procedure is being followed. Safety and compliance with the Occupational Health and Safety Act and Regulations thereunder, shall be an integral part of the design.~~

~~The Contractor shall continue to for the Consultant's review and acceptance a minimum of four weeks in advance of the Work. The Contractor shall be fully responsible for the results obtained by the use of these sealed drawings, with the Professional Engineer also assuming responsibility, as the Contractor's Agent, for the results obtained.~~

~~Site The Consultant's review and acceptance shall not be considered as relieving the Contractor of the responsibility for the safety of his methods or equipment, nor from carrying out the work in full accordance with the Contract requirements.~~

~~Repair to any damage to property, such as earth fills and stream banks, resulting from the existence of berms, and all associated costs shall be the sole responsibility of the Contractor.~~

### 6.3.2.2 Girder Erection Procedure

The Contractor shall submit a detailed girder erection procedure to the Consultant for review and acceptance a minimum of 4 weeks in advance of erection. The erection procedure shall include drawings and supporting documents necessary to describe the following:

- Traffic Accommodation Strategy (TAS);
- Access to the Work, including temporary access berms and/or work bridges;
- Details of temporary works and supporting structures, including:
  - Location, elevation, and grade of support bearings;
  - Theoretical top of girder elevations at bearing and splice locations; and
  - Vertical, horizontal, and longitudinal position adjustment mechanisms;
- An as constructed survey of substructure elements, including:
  - Location and elevation of all bearing grout pad recesses including anchor rod voids;
  - Shim height required at each bearing location; and
  - Longitudinal and transverse measurements between centreline of bearings of all substructure elements;
- Superstructure layout plan, including installation details of reference lines and markings of substructure and bearing components used to determine final bearing and girder positions, and theoretical top of girder elevations at substructure bearings and splice locations;
- Type and capacity of cranes;
- Sequence of operation including position of cranes and delivery trucks;
- Position of cranes relative to substructure elements such as abutment backwalls, with details of load distribution of wheels and outriggers;
- Lifting devices and lifting points showing lifting forces;
- Girder stabilization details, methods of maintaining girder location and alignment, and details of blocking for girder and bearings;
- Diaphragm and bracing installation schedule and sequence;
- Bolt tightening schedule and sequence;
- Grout pad construction; and
- Temporary supporting structures release and removal.

Installation of bearings shall be in accordance with Subsection 8.4, Installation.

Girder layout and member identification contained in the erection procedure shall be consistent with the girder layout and member identification shown on the Drawings.

The girder erection procedure shall be signed and sealed by a Professional Engineer registered in the Province of Alberta. Safety and compliance with the Occupational Health and Safety Act and Regulations thereunder shall be an integral part of the procedure.

The Contractor shall not commence any erection work until review of the proposal girder erection procedure by the Consultant has been obtained, completed and all comments arising from that review have been addressed to the satisfaction of the Consultant. The Contractor's project manager ~~and~~ field superintendent ~~may be required to~~, and representatives directly involved in the supervision of the work, shall attend a pre-job construction milestone meeting at a location determined by the Consultant prior to commencement of ~~any field~~ the Work.

The Consultant's review and acceptance shall not be considered as relieving the Contractor of the responsibility for the safety of his methods or equipment, nor from carrying out the Work in full accordance with the girder erection procedure, drawings and specifications.

~~Before erection begins the Contractor shall do a complete superstructure layout by means of chalk lines and markings applied to all substructure units, showing bearing and girder positions in accordance with the Contractor's reviewed layout plan.~~

6.3.2.3 The Contractor shall follow the girder erection procedure at all times.

#### 6.3.2.26.3.2.3 Fall Protection for Girder Erection and Deck Forming

In order to provide a safe working area for girder erection and deck formwork, the Contractor shall provide 100% fall protection and a safe work procedure. The design of the fall protection and the safe work procedure shall be designed, signed and sealed by a Professional Engineer registered in the Province of Alberta. The Contractor shall submit the design and safe work procedure to the Consultant a minimum of two weeks prior to commencement the Work.

#### 6.3.2.36.3.2.4 6.3.2.4 Straightening Bent Material

Straightening of plates, angles or other shapes will not be permitted without the acceptance of the Department and the Consultant. In all cases, a detailed written procedure prepared by a Professional Engineer registered in writing the Province of Alberta must be submitted by the Contractor, and reviewed and accepted by the Consultant and the Department prior to any straightening being undertaken.

Following the accepted straightening of a bend or buckle, the surface of the metal shall be ~~carefully~~ inspected for evidence of fractures, which may include nondestructive testing. The Consultant and the Department will determine the type of NDT required and arrange for the testing. All costs associated with straightening bent material shall be the responsibility of the Contractor.

~~6.3.2.46.3.2.5~~ **6.3.2.5** Assembly

~~The parts~~Members shall be ~~accurately~~ assembled as shown on the Drawings and all fabrication match marks shall be followed. The material shall be carefully handled to avoid damage. Hammering, ~~which will injure shall not damage~~ or distort the members, ~~shall not be permitted.~~ Bearing.

Contact surfaces and surfaces of bolted connections shall be cleaned to be in permanent contact shall be clean the satisfaction of the Consultant before the members are assembled. Contact surfaces that have not been cleaned to the satisfaction of the Consultant shall be unbolted and cleaned.

Splices and field connections shall have ~~one-half~~ $\frac{1}{2}$  of the holes filled with bolts and cylindrical erection pins (half bolts and half pins evenly distributed throughout the splice or connection) before bolting. Splices and connections carrying traffic during erection shall have ~~three-fourths~~ $\frac{3}{4}$  of the holes filled.

Fitting up bolts, if used, shall be distinguishable from the final bolts and shall be of the same nominal diameter ~~as the bolts, and~~. Cylindrical erection pins shall be sized to accurately fit the holes.

~~Should~~When adjustments in elevation of the girder splices ~~become necessary, to allow free rotation of the joint is required~~, only enough pins or bolts shall be removed to allow free rotation of the splice.

~~6.3.2.56.3.2.6~~ **6.3.2.6** High -Tensile -Strength Bolted Connections

~~6.3.2.5.16.3.2.6.1~~ **(a)** — General

Bolted parts shall fit solidly together when assembled. Contact surfaces, including those adjacent to the washers, shall be de-scaled or carry the normal tight mill scale ~~as determined by the Consultant~~. Contact surfaces shall be free of dirt, paint, oil, loose scale, burrs, pits and other defects that would prevent solid seating of the parts. Bolts in exterior girders shall be installed with the heads on the outside face of the girder web ~~and~~. Bolts located in the bottom flange of all girders shall have the heads installed on the bottom ~~faces~~face of the lower flangessplice plate unless noted otherwise ~~noted~~. Nuts for bolts that will be partially embedded in concrete shall be located on the side of the member that will be encased in concrete.

Connections shall be assembled with a hardened washer under the bolt head or nut, whichever is the element turned in tightening. The smooth side of the hardened washer shall be placed against the structural steel. Surfaces of bolted parts in contact with the bolt head and nut shall be parallel.

For sloped surfaces, bevelled washers shall be used. The bevelled washers shall be designed to produce a bearing surface normal to the bolt axis.

Bolts shall be of new quality and stored in weatherproof containers to prevent loss of lubrication or accumulation of dirt.

~~All~~The elevation and alignment of girders, including bracing and diaphragms, shall be ~~erected~~ with elevations reviewed and alignments checked ~~accepted~~ by the Consultant, prior to any bolt tightening ~~unless otherwise accepted by the Department and the Consultant.~~

~~6.3.2.5.26.3.2.6.2~~ (b) Bolt Tension

Each bolt shall be tightened so as to provide, when all bolts in the joint are tight, at least the minimum bolt tension shown in ~~the following table~~ Table 6-1: Bolt Tension, for the size of bolt used.

~~Table 1~~ 6-1: Bolt Tension

Specified Bolt Size <del>(A325M Bolts)</del>	Minimum Bolt Tension		Commonly Supplied Equivalent Imperial Size <del>(A325 Bolts)</del>	Minimum Bolt Tension	
	Kilonewtons	pounds-force		Kilonewtons	pounds-force
<u>(A325M Bolts)</u>			<u>(A325 Bolts)</u>		
M16X2	94	21,180	5/8	85	19,200
M20X2.5	147	33,050	3/4	126	28,400
M22X2.5	181	40,700	7/8	175	39,250
M24X3	212	47,660	1	227	51,500
--	--	--	1 1/8	251	56,450
M30X3.5	337	75,760	1 1/4	319	71,700
--	--	--	1 3/8	380	85,450
M36X4	490	110,160	1 1/2	463	104,000

~~6.3.2.5.3~~ ~~6.3.2.6.3~~ (c) — Turn of Nut Tightening

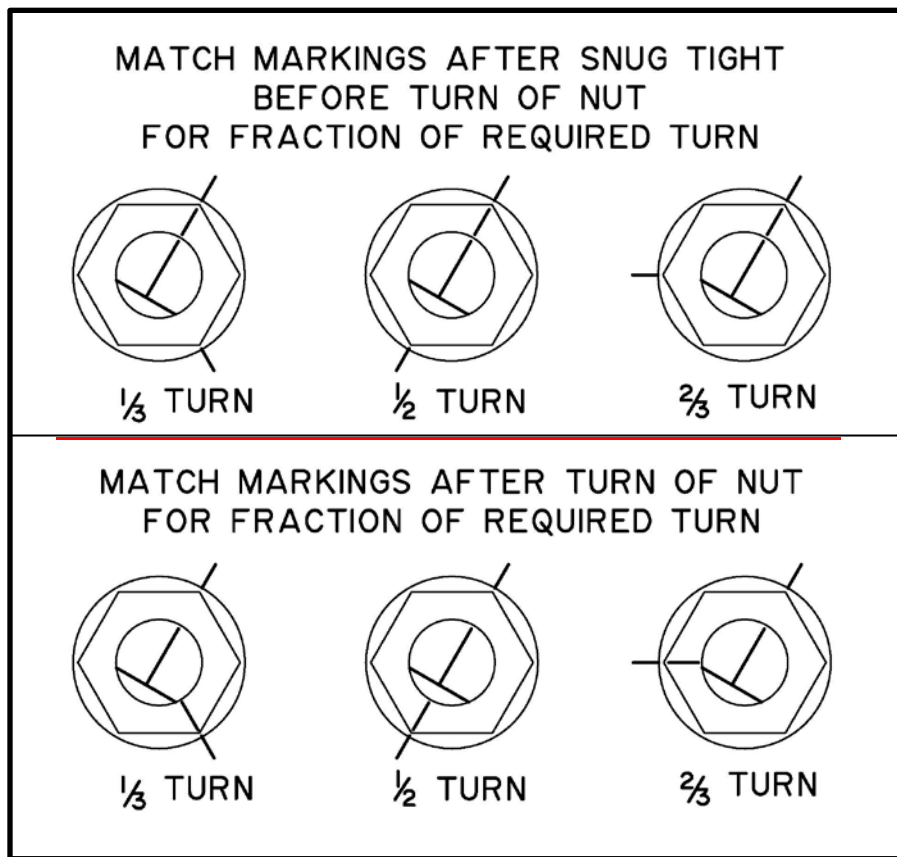
Tightening of all high strength bolts shall be by the turn-of-nut method. Before final tightening there shall be a sufficient number of bolts brought to a “snug tight” condition to ensure that the parts of the joint are brought into full contact with each other. Snug tight is defined as the tightness attained by a few impacts of an impact wrench or the full effort of a man using an ordinary spud wrench. Following this initial operation, bolts shall be placed in any remaining holes in the connection and brought to snug tightness. After all bolts have been taken to the snug tight condition, the Contractor shall match mark the outer face of each nut and protruding end of bolt to have a common reference line to determine the relative rotation in accordance with Figure 6-1: Required Match Markings for Turn of Nut Tightening. All bolts in the joint shall then be ~~tightened~~ tightened additionally by the applicable amount of nut rotation specified below, with tightening progressing systematically from the most rigid part of the joint to its free edges. During this operation there shall be no rotation of the part not turned by the wrench.

Amount of rotation of nut relative to bolt, regardless of which is turned:

- ~~—~~ 1/3 turn where bolt length is 4 bolt diameters or less
- ~~—~~ 1/2 turn where bolt length is over 4 bolt diameters and not exceeding 8 bolt diameters
- ~~—~~ 2/3 turn where bolt length exceeds 8 bolt diameters

Notes

~~—~~ The rotational tolerance shall be +1/6 turn (60° over, °), - 0 (nothing under less than the minimum specified). The bolt length of bolt shall be measured from underside of the bolt head.

**(d) — Figure 6-1: Required Match Markings for Turn of Nut Tightening****6.3.2.5-46.3.2.6.4** Reuse of Fasteners

High strength bolts shall be tensioned only once and shall not be reused. Retightening previously tightened bolts, which may have been loosened by tightening of adjacent bolts, shall not be considered as reuse.

**6.3.2.5-56.3.2.6.5** (e) — Inspection

The Contractor shall provide safe and adequate access meeting Occupational Health and Safety requirements to all working areas, including all necessary scaffolding to enable the Consultant to carry out his inspection. The Contractor shall provide a competent workman to assist the Consultant in the checking of bolt tightening work.

**6.3.2.7** — The Contractor shall visually confirm all bolts have been tightened by the amount ~~Misfits~~

~~The correction of relative match marking rotation. In addition, the Contractor shall confirm bolt tension of 10% of all bolts by calibrated wrench tightening in accordance with CSA S6, Annex A.10.1.6.8, Inspection of Turn of Nut Tightened Bolts. A minimum of three typical bolts of each diameter and length shall be tested from the bolts installed. The wrenches shall be calibrated at least once each working day in a device capable of indicating actual bolt tension.~~

~~6.3.2.7 Misfits minor misfits involving any reaming, cold cutting and chipping for secondary members may be allowed. However, if reaming is considered required, it~~

~~Misfits shall be immediately reported to the Department and the Consultant. The Contractor shall submit a detailed repair procedure to the Consultant and the Department for review. If accepted, the repairs shall be made in the Consultant's presence and acceptance to correct misfits. Repairs shall not be completed until the repair procedure has been reviewed and accepted by the Consultant and the Department. Repair procedures, including reaming of secondary members may be considered acceptable. Reaming of primary members will not be permitted.~~

~~6.3.2.6~~ ~~6.3.2.8~~ ~~6.3.2.8~~ Girder Adjustment

~~It is essential that the girders are erected with utmost attention being given to girder positioning, alignment, and elevation. Adjustment to girder position, bearing location and bearing elevation shall be done in order completed to achieve as closely as possible the lines and grades shown on the Drawings or those reviewed and accepted by the Consultant.~~

The Contractor shall ~~ensure that~~ maintain the structural steel ~~is maintained~~ in correct alignment at all times during construction.

~~6.3.2.7~~ ~~6.3.2.9~~ ~~6.3.2.9~~ Removal of Temporary Supporting Structures, Berms, and Clean-up

Upon completion of ~~the girder~~ erection ~~and before final acceptance~~, the Contractor shall remove all earth material or temporary supporting structures ~~placed in the stream channel or elsewhere used~~ during construction. ~~He~~ The Contractor shall remove all piling, excavated or surplus materials, rubbish and temporary buildings, replace or renew any damaged fences, and restore in an acceptable manner all property damaged during the execution of his work. Disposal of surplus materials shall be in a manner and location satisfactory to the Consultant.

The Contractor shall leave the bridge site, roadway and adjacent property in a ~~neatly restored and presentable~~ condition, ~~satisfactory~~ acceptable to the Consultant. When required, ~~he~~ the Contractor shall provide written evidence that affected property owners or regulatory agencies have been satisfied.

~~All steel shall be left clean and free of oil, grease, mud, dust, road spray or other foreign matter.~~

~~6.4~~ ~~6.4~~ ~~6.4~~ Strip Seal and Cover Plated V-Seal Deck Joints

~~After strip seals and v-seals have been installed to the satisfaction of the Consultant, they shall be tested by the Contractor in the presence of the Consultant for leakage. Any areas of leakage shall be repaired and retested. Defective or torn seals shall be removed and replaced.~~



The Contractor shall provide a written warranty for the performance of the deck joint assemblies for a period of five years. The warranty shall be provided to the Consultant prior to the issuance of the Construction Completion Certificate. The deck joint warranty shall provide for the replacement, installation and/or repair of the deck joint assemblies, including all concrete, reinforcing steel, and necessary traffic control should performance, unsatisfactory to the Department, occur during the five year period. The cost of furnishing all materials, labour, tools, equipment, and incidentals necessary to replace, install, and/or repair the deck joint assembly shall be included in the warranty.

#### **6.46.5 Payment**

##### **6.4.16.5.1 Payment for the Supply of Structural Steel**

##### **6.5.1.1 Supply Girders and Associated Material**

Payment for the supply of structural steel will be made on the basis of at the lump sum price bid. Items to be included in for "Supply of Structural Steel and Associated Material shall be Supply" for the type and size specified, and will be full compensation for the supply and fabrication of structural steel; including all labour, equipment, tools and incidentals necessary to complete the Work as indicated shown on the Drawings and to the satisfaction of the Consultant.

Payment for the 90% of the lump sum price bid will be paid once the structural steel has been acceptably supplied and delivered to the bridge site. The remaining 10% of the lump sum price bid will be paid once the structural steel has been acceptably installed.

##### **6.5.1.2 Delivery of Girders**

Payment for the delivery of structural steel will be made on the basis of at the lump sum price bid for "Structural Steel – Delivery" for the type and shall include size specified, and will be full compensation for loading; hauling to the costs to deliver project site; unloading; and all structural steel and associated materials labour, equipment, tools and incidentals necessary to complete the bridge site including Work as shown on the Drawings and to the satisfaction of the Consultant.

All necessary approvals and permits from the Motor Transport Board and/or the appropriate local road authorities, cleaning of girders to remove any foreign material materials will be considered incidental to the Work and no separate separator or additional payment will be made.

90% of the lump sum price bid will be paid once the structural steel has been acceptably supplied and delivered to the bridge site. The remaining 10% of the lump sum price bid will be paid once the structural steel has been acceptably installed.

6.5.1.3 Erection

Payment for the erection of ~~Girders~~structural steel will be made ~~on the basis of~~at the lump sum ~~price~~prices bid for “Structural Steel – Erection” for the type and size specified, and will be full compensation for the cost of furnishing all materials, labour, tools, equipment, tools and incidentals necessary to acceptably erect the structural steel girders and associated material and complete site clean-up the Work as shown on the Drawings and to the satisfaction of the Consultant.

6.5.2 Deck Joint Assemblies6.5.2.1 Supply and Delivery

Payment for the supply and delivery of deck joint assemblies will be made ~~on the basis of~~at the lump sum ~~price~~prices bid. ~~Items to be included in Supply of~~ for “Deck Joint Assemblies shall be as indicated on the Drawings, Supply and Deliver” for the types specified, and will be full compensation for the supply and fabrication of the deck joint assemblies; loading; hauling to the project site; unloading; and all labour, equipment, tools and incidentals necessary to complete the Work as shown on the Drawings and to the satisfaction of the Consultant.

90% of the lump sum price bid will be paid once the deck joint assemblies have been acceptably supplied and delivered to the bridge site. The remaining 10% of the lump sum price bid will be paid once the deck joint assemblies have been acceptably installed, concrete placement and curing has been completed, and all tolerances have been reviewed and accepted by the Consultant.

6.5.2.2 Installation

Payment for the installation of deck joint assemblies will be made ~~on the basis of~~at the lump sum ~~price bid. Items to be included in Installation of~~ prices bid for “Deck Joint Assemblies shall be Install” for the types specified, and will be full compensation for all labour, equipment, tools and incidentals to install the deck joint assemblies as indicated shown on the Drawings.

~~When materials are delivered and to the work site, payments for Supply of Structural Steel Girders and Associated Materials, Delivery of Girders, and Supply and Delivery of Deck Joint Assemblies, will be made to a maximum of 90% of the bid price satisfaction of the materials and delivery. Payment for the remainder of the prices bid for supply and delivery will be made as the materials are acceptably installed. Consultant.~~

# STANDARD SPECIFICATIONS FOR BRIDGE CONSTRUCTION

## SECTION 7 PRECAST CONCRETE UNITS

### TABLE OF CONTENTS

<b>7.1</b>	<b>General</b>	<b>7-1</b>
<b>7.2</b>	<b>Supply and Manufacture</b>	<b>7-1</b>
7.2.1	Standards	7-1
7.2.2	Qualification	7-1
7.2.3	Engineering Data	7-2
7.2.3.1	Shop Drawings	7-2
7.2.3.2	Design Notes and Independent Check Notes	7-3
7.2.3.3	Mill Test Reports	7-4
7.2.3.4	Product Data Sheets	7-4
7.2.3.5	Prestressing Strand Load/Elongation Curve and Jack Calibration Certificates	7-4
7.2.3.6	Concrete Mix Design Submission Requirements	7-4
7.2.3.7	Construction Data Sheets	7-5
7.2.4	Materials	7-6
7.2.4.1	Hydraulic Cement	7-6
7.2.4.2	Water	7-6
7.2.4.3	Silica Fume	7-6
7.2.4.4	Aggregates	7-6
7.2.4.5	Air Entraining Agent	7-6
7.2.4.6	Admixtures	7-7
7.2.4.7	Concrete	7-7
7.2.4.8	Reinforcing Steel	7-7
7.2.4.9	Prestressing Strand	7-8
7.2.4.10	Lifting Hooks	7-8
7.2.4.11	Miscellaneous Steel, Steel Diaphragms and Fasteners	7-8
7.2.4.12	Anchor Rods for Bridgerail	7-8
7.2.4.13	Voids, Ducts, and Conduit	7-9
7.2.4.14	Bearings	7-9
7.2.4.15	Galvanizing	7-9
7.2.5	Manufacture	7-10
7.2.5.1	Forms	7-10
7.2.5.2	Reinforcing Steel	7-10
7.2.5.3	Prestressing Strand	7-11
7.2.5.4	Void, Duct, Conduit and Reinforcement Placing Tolerances	7-12
7.2.5.5	Identification of Precast Concrete Units	7-13
7.2.5.6	Concrete Measuring, Mixing and Placing	7-13
7.2.5.7	Concrete Temperature	7-13
7.2.5.8	Finished Riding Surface	7-13
7.2.5.9	Camber Hubs	7-13
7.2.5.10	Concrete Finish	7-14
	7.2.5.10.1 Class 1 Ordinary Surface Finish	7-14
	7.2.5.10.1.1 Unformed Surfaces	7-14
	7.2.5.10.1.2 Formed Surfaces	7-14

	7.2.5.10.2	Class 2 Rubbed Surface Finish .....	7-15
	7.2.5.10.3	Class 3 Bonded Concrete Surface Finish .....	7-15
	7.2.5.10.4	Class 4 Floated Surface Finish .....	7-15
	7.2.5.10.5	Class 5 Floated Surface Finish, Broomed Texture .....	7-16
	7.2.5.11	Curing .....	7-16
	7.2.5.11.1	Prestressed Precast Concrete Units .....	7-17
		7.2.5.11.1.1 Curing in the Form .....	7-17
		7.2.5.11.1.2 Curing after Removal from the Form .....	7-17
	7.2.5.11.2	Non-Prestressed Precast Concrete Units .....	7-18
		7.2.5.11.2.1 Elevated Temperature Curing .....	7-18
		7.2.5.11.2.2 Moist Curing .....	7-18
	7.2.5.12	Release of Prestressing Strand .....	7-18
	7.2.5.13	Repairing Concrete Defects .....	7-19
		7.2.5.13.1 Cracks .....	7-19
		7.2.5.13.2 Honeycombs and Spalls .....	7-20
	7.2.5.14	Type 1c Sealer .....	7-20
	7.2.5.15	Sandblasting .....	7-21
	7.2.5.16	Dimensional Tolerances of Precast Concrete Units .....	7-21
	7.2.5.17	Handling and Storage .....	7-22
7.2.6		Testing and Inspection .....	7-22
	7.2.6.1	Access .....	7-22
	7.2.6.2	Responsibility .....	7-22
	7.2.6.3	Witness Points .....	7-23
	7.2.6.4	Testing by the Contractor .....	7-23
	7.2.6.5	Release Strength Test Cylinders .....	7-23
	7.2.6.6	28 Day Strength Testing .....	7-24
	7.2.6.7	Notification to Ship .....	7-24
	7.2.6.8	Fabrication Outside of Canada .....	7-24
7.2.7		Failure to Meet Strength Requirements .....	7-26
	7.2.7.1	Right of Rejection .....	7-26
	7.2.7.2	Coring .....	7-26
	7.2.7.3	Payment Adjustment Schedule .....	7-26
<b>7.3</b>		<b>Precast Concrete Girder Erection .....</b>	<b>7-27</b>
	7.3.1	General .....	7-27
	7.3.2	Transportation, Handling and Storing Materials .....	7-28
	7.3.3	Temporary Supporting Structures and Berms .....	7-29
	7.3.4	Girder Erection Procedure .....	7-31
	7.3.5	Fall Protection for Girder Erection and Deck Forming .....	7-33
	7.3.6	Girder Adjustments .....	7-33
	7.3.7	Lifting Hooks and Lifting Holes .....	7-34
	7.3.8	Post-Tensioning System .....	7-34
		7.3.8.1 General .....	7-34
		7.3.8.2 Standards .....	7-34
		7.3.8.3 Qualification .....	7-34
		7.3.8.4 Submittals .....	7-35
		7.3.8.5 Materials .....	7-35
		7.3.8.5.1 Prestressing Strand .....	7-35
		7.3.8.5.2 Anchorages and Distribution .....	7-35

	7.3.8.5.3	Ducts .....	7-35
	7.3.8.5.4	Concrete .....	7-36
	7.3.8.5.5	Grout .....	7-36
7.3.8.6		Equipment .....	7-36
	7.3.8.6.1	Stressing .....	7-37
	7.3.8.6.2	Grouting .....	7-38
7.3.8.7		Construction .....	7-38
	7.3.8.7.1	Checking Post-Tensioning Ducts .....	7-38
	7.3.8.7.2	Welding .....	7-38
	7.3.8.7.3	Post-Tensioning .....	7-39
	7.3.8.7.4	Concreting .....	7-39
	7.3.8.7.5	Grouting .....	7-40
		7.3.8.7.5.1 Compressive Strength Test .....	7-41
		7.3.8.7.5.2 Bleed Test .....	7-41
		7.3.8.7.5.3 Fluidity Test .....	7-41
		7.3.8.7.5.4 Mud Balance Test .....	7-41
	7.3.8.8	Inspection .....	7-41
7.3.9		Removal of Temporary Supporting Structures and Site Clean-up .....	7-42
<b>7.4</b>	<b>Payment</b> .....		<b>7-42</b>
	7.4.1	Supply .....	7-42
	7.4.2	Delivery .....	7-42
	7.4.3	Erection .....	7-43
	7.4.4	Post-tensioning and Grouting .....	7-43



## 7.1 General

This specification is for the supply, ~~manufacture, delivery and~~ erection of prestressed, and post-tensioning of precast concrete ~~bridge units and~~. 'Unit' and 'girder' shall be considered interchangeable throughout this specification.

Precast concrete units shall include girders, abutment and pier caps, bracing, fasteners, shoe plates, deck drains, anchor rods, dowels, buffer angles, anchor rod sleeves, miscellaneous precast components and associated materials as shown on the Drawings or specified in the Special Provisions of the Contract.

## 7.2 ~~7.2~~ Supply and Manufacture

A pre-fabrication meeting is required prior to commencement of fabrication of precast concrete ~~elements~~ units. The meeting will be held at ~~fabricator's plant~~ the fabrication facility and the Contractor shall ensure the plant superintendent and plant manager responsible for the Work and any ~~manufacturer's~~ fabricator's representatives directly involved in the ~~specialized~~ Work are in attendance. The ~~Department~~ Consultant will conduct ~~this~~ the pre-fabrication meeting at a mutually agreed upon date after the shop drawings and stressing calculations have been reviewed. ~~The Contractor shall provide two weeks notice to the Department/ and accepted by the~~ Consultant prior to the meeting.

7.2.1—The Contractor shall be responsible for all costs incurred by the Consultant to attend the pre-fabrication meeting and to inspect precast concrete units fabricated outside the Province of Alberta. The Contractor shall also be responsible for the cost of the Department's representative to attend the pre-fabrication meeting and three additional trips to review the fabrication.

### 7.2.1 Standards

The manufacture of prestressed and precast concrete ~~bridge~~ units shall be in accordance with The Canadian Standards Association (CSA) Standard A23.4 and the Precast/Prestressed Concrete Institute (PCI) Quality Control Manual MNL-116, with the most stringent of the requirements governing.

~~Where imperial/metric conversions are necessary, The National Standard of Canada, CAN3-Z234.1-79 shall be used as the basis of conversion.~~

### 7.2.2 ~~7.2.2~~ Qualification

The Contractor shall notify the Consultant and the Department ~~and Consultant~~ of any subcontractors in his employ. The Contractor shall ~~remain~~ be responsible for the Work of ~~the~~ all subcontractors. All terms of the Contract, such as right of access, shall apply to the subcontractor.

~~The fabricator shall operate a recognized~~ Precast concrete ~~fabricating plant~~ units shall be supplied and be fully manufactured by a fabricator certified by the Canadian Precast/Prestressed Concrete Institute (CPCI) Certification Program in the applicable Product Group classification.

~~7.2.3—The fabrication of precast concrete units shall be done in a sufficiently large environmentally controlled permanent building capable of supplying and manufacturing products in a well-organized and continuous operation. The building temperature shall be maintained between 15 °C and 30 °C and prevent contamination and/or deterioration of materials.~~

### 7.2.3 Engineering Data

#### 7.2.3.1 ~~7.2.3.1~~—Shop Drawings

~~Five copies of the Shop drawings showing all necessary fabrication details shall be submitted to the Consultant for review and acceptance a minimum of 4 weeks in advance of the commencement of fabrication. Review comments provided by the Consultant and/or the Department shall be incorporated into the shop drawings and resubmitted to the Consultant for review and acceptance prior to the commencement of fabrication.~~

~~Shop drawings shall be electronic unlocked PDF format. Each shop drawing shall include the Department's shop drawing identification block and have a sufficient blank space for the Consultant's review stamp. The Department's shop drawing identification block will be provided to the Contractor upon request. As a minimum, the following information shall be included on shop drawing submissions:~~

- ~~• Properties of all materials used;~~
- ~~• Dimensional information of all precast concrete units, such as;~~
- ~~• Reinforcing steel, blockouts,;~~
- ~~• Prestressing strand;~~
- ~~• Steel diaphragms;~~
- ~~• Miscellaneous steel;~~
- ~~• Blockouts and Voids;~~
- ~~• Stressing system, anchorage;~~
- ~~• Anchorage and hold down devices,;~~
- ~~• Void support system; and~~
- ~~• Screed rail shall be submitted to the Consultant for review prior to manufacturing. The shop drawings shall be legible and of adequate quality to be reproduced and microfilmed. Each drawing shall have a sufficient blank space for the Consultant's review stamp. details.~~

~~The shop drawings will be reviewed by the Consultant solely to ascertain general conformance with codes and specifications. The Consultant's review of the shop drawings and acceptance shall not be construed considered as relieving the Contractor from his of the responsibility for errors or omissions. All shop drawings will be stamped as follows: completing the Work in accordance with the Contract requirements.~~

~~"This review applies to general arrangements and details of design but not to dimensions or details of fabrication and is subject to the requirements of specifications and to such corrections as may be marked here on."~~



~~Fabrication shall not commence prior to the review of the~~The Contractor shall incorporate as-built construction conditions into shop drawings.

~~Alberta Transportation bridge file number and project name shall be shown on~~One paper copy and one electronic copy (PDF format) of as-built shop drawings .

#### ~~7.2.3.2~~ Stressing Calculations

~~Four copies of the stressing calculations showing elongations and gauge pressures as well as the strand release sequence data shall be submitted to the Consultant for review prior to manufacturing. Jack calibrations, performed within the previous six months, shall be included~~within 3 weeks of construction completion.

#### ~~7.2.3.3~~ Stressing Steel Certificate

#### ~~7.2.3.2~~ Design Notes and Independent Check Notes

~~The Contractor shall submit design notes and independent check notes of stressing calculations signed and sealed by the design engineer of record and by an independent checker. If modifications to the Contract requirements are proposed, the Contractor shall submit design notes, independent check notes, and shop drawings signed and sealed by his design engineer of record and by an independent checker.~~

~~The design engineer of record and the independent checker shall be Professional Engineers registered in the Province of Alberta. Design notes and independent check notes shall be submitted to the Consultant for review and acceptance a minimum of 4 weeks in advance of the commencement of fabrication. Review comments provided by the Consultant and/or the Department shall be incorporated into the design notes and independent check notes and shop drawings and resubmitted to the Consultant for review and acceptance prior to the commencement of fabrication. The design engineer of record and independent checker shall submit separate signed and sealed design notes and independent check notes. The design and check notes shall be presented in a legible and logical format, clearly identify material properties, and sufficiently detailed to allow a technical review of design concepts and assumptions used.~~

~~The independent checker may be employed by the same company as the design engineer of record. The independent check must be completed fully independent of the design engineer of record, including a complete re-analysis of all aspects of the design including calculations and engineering, preferably by a methodology or computer program other than that used by the design engineer of record. The design engineer of record and independent checker shall ensure that the shop drawings are complete and accurately convey the design criteria and assumptions used in their designs.~~

~~The design notes, independent check notes, and shop drawings will be reviewed by the Consultant solely to ascertain general conformance with codes and specifications. The Consultant's review and acceptance shall not be considered as relieving the Contractor of the responsibility for completing the Work in accordance with the Contract requirements.~~

The Contractor shall incorporate and submit as-built design notes, check notes, and shop drawings for records at the completion of construction. One paper copy and one electronic copy (PDF format) of as constructed shop drawings, design and check notes, and supplier inspection construction records shall be submitted to the Consultant within 3 weeks of construction completion.

#### 7.2.3.3 Mill Test Reports

Mill test reports shall be provided for all materials in English. Mill test reports shall be submitted to the Consultant for review and acceptance 4 weeks prior to the commencement of fabrication.

Where mill test reports originate from a mill outside Canada or the United States of America, the Contractor shall have mill test reports verified by a certified laboratory in Canada by testing the material to the specified material standards, including boron content. The testing laboratory shall be certified to ISO/IEC 17025 by an organization accredited by the Standards Council of Canada for the tests required. Samples for testing shall be collected by personnel employed by the certified laboratory. A verification letter shall be provided by the certified laboratory that includes at a minimum, the applicable mill test reports, testing standards, date of verification testing, and declaration of material compliance with Contract requirements. The verification letter shall be signed by an authorized officer of the certified laboratory.

#### 7.2.3.4 Product Data Sheets

Product data sheets shall be provided for all material. Product data sheets shall be submitted to the Consultant for review and acceptance 4 weeks prior to the commencement of fabrication.

All product data sheets shall be legible and provided in English.

#### 7.2.3.5 Prestressing Strand Load/Elongation Curve and Jack Calibration Certificates

A copy of the load/elongation curve for each lot of ~~stressing steel~~ prestressing strand shall be submitted to the Consultant for review two weeks prior to manufacturing. All prestressing strand load/elongation curves shall be legible and in English.

7.2.3.4 Jack calibrations shall be completed no more than 6 months prior to stressing. Jack calibration certificates shall be provided to the Consultant for review and acceptance with stressing calculation design notes and independent check notes.

#### 7.2.3.27.2.3.6 Concrete and Grout-Mix Design Submission Requirements

A copy of the concrete mix design and the grouting mortar mix design including applicable material test reports shall be submitted to the Consultant for review a minimum of two weeks prior to manufacturing. Material test reports shall be current and fully represent materials to be used in production. The mix design shall indicate the design strength, proportions of the constituent materials, type and brand of cement, type and brand of silica fume, origin of aggregates and brand names of all admixtures.

~~The sampling and testing of aggregates shall be completed by a concrete testing laboratory certified to CSA A283. Concrete mix designs, including the review of all material test reports, shall be signed and sealed by a Professional Engineer registered in the Province of Alberta employed by a concrete testing laboratory certified to CSA A283. The Engineer shall also provide a professional opinion indicating that the concrete mix is suitable for the intended use and can be expected to meet specification requirements.~~

~~Alternatively, concrete mix designs, including the sampling and testing of aggregates and review of material test reports may be completed by a qualified professional employed by the concrete supplier. When the concrete mix design is completed by the concrete supplier it shall be reviewed for compliance with the respective specifications, signed and sealed by a Professional Engineer registered in the Province of Alberta employed by an independent concrete testing laboratory certified to CSA A283. The independent review Engineer shall also provide a professional opinion indicating that the concrete mix is suitable for the intended use and can be expected to meet specification requirements.~~

~~The mix design~~ Concrete mix designs shall be submitted to the Consultant in accordance with Subsection 4.4.4, Concrete Mix Design Submission Requirements for review and acceptance.

The mix design shall specify the upper slump limit for the superplasticized concrete at which the mix is stable without any segregation. The slump of the concrete used in the production shall be 10 mm below the upper limit identified in the mix design.

The Contractor is required to complete a trial batch for each concrete mix. The trial batches shall be performed a minimum of 28 days prior to placement of concrete. The Contractor's quality representative shall attend all trial batches. All trial batch testing shall be repeated in conjunction with required aggregate testing. The trial batch shall include one microscopic air-void analysis performed by an independent CSA A283 certified testing laboratory in order to determine the spacing factor of the hardened concrete. The test sample shall be made from a trial concrete batch, vibrated into a cylinder mould so as to represent the level of vibration of the production concrete in the forms. If adjustments to the mix design are necessary, the air-void analysis shall be repeated.

Only the reviewed and accepted mix design shall be used. No changes to cast units. Changes in cement type, and/or decreasing cement content shall be construed as a change in the reviewed mix design will be permitted. If changes are proposed by the Contractor, a new concrete mix design review letter shall be provided in accordance with Subsection 4.4.4, Concrete Mix Design Submission Requirements, and will not be allowed trial batches completed.

#### ~~7.2.3.37.2.3.7~~ 7.2.3.5 Construction Data Sheets

~~During manufacture, the~~ Construction data sheets shall be kept up to date and made available for the ~~Consultant's inspection.~~ Consultant's review throughout fabrication. Copies of the Construction Data Sheets shall be provided to the Consultant upon completion of the Contract. One copy of the stressing data sheets for each bridge precast concrete unit shall also be submitted with the Construction Data Sheets.

7.2.4 ~~7.2.4~~ Materials7.2.4.1 ~~7.2.4.1~~ Hydraulic Cement

Hydraulic cement ~~conforming to shall meet~~ the requirements of CSA Standard A3001 ~~shall be used~~.

~~7.2.4.2~~ Water7.2.4.2 Water

Water to be used for mixing concrete ~~or mortar, concrete patching materials, or concrete finishing materials~~, shall conform to the requirements of CSA Standard A23.1 and shall be free from ~~injurious amount~~ harmful amounts of alkali, organic materials or deleterious substances. The Contractor shall not use slurry water, treated wash water or water from shallow, stagnant or marshy sources.

~~7.2.4.2~~ ~~7.2.4.3~~ 7.2.4.3 Silica Fume

~~10% condensed silica fume by weight of cement ( $\pm 0.5\%$ ) shall be used in all precast concrete.~~ Condensed Silica fume shall conform to the requirements of CSA Standard A3001 ~~for a~~ Type SF ~~supplementary cementing material, with a~~ have a minimum SiO<sub>2</sub> content of ~~at least~~ 85%, a maximum loss on ignition of ~~10%~~ 10%, and no more than 1% SO<sub>3</sub> content. ~~An acceptable, compatible, superplasticizing admixture shall be used together with the silica fume.~~

~~7.2.4.3~~ ~~7.2.4.4~~ 7.2.4.4 Aggregate Testing Aggregates

~~Aggregate tests and analysis shall be performed and submitted to the Consultant for review with the concrete mix design as follows:~~

~~(a)~~ Standard Weight Aggregates

Fine and coarse standard weight aggregates shall ~~be as per section 4.4.4 of Specifications for Bridge Construction with~~ meet the requirements of Subsection 4.4.4, Concrete Mix Design Submission Requirements.

The maximum coarse aggregate size ~~of~~ shall be 14 mm.

~~(b)~~ Lightweight Aggregates

~~Fine and coarse lightweight aggregates shall conform to the requirements of the ASTM Standard C330, with maximum aggregate size of 14 mm.~~

~~7.2.4.4~~ ~~7.2.4.5~~ 7.2.4.5 Air Entraining Agent

Air entraining agent shall conform to the requirements of the ASTM ~~Standard~~ C260.

~~7.2.4.6~~ ~~7.2.4.6~~ — ~~Chemical~~ Admixtures

Admixtures shall be compatible with all mix constituents.

Water reducing agents and superplasticizers shall conform to ASTM ~~Admixtures~~

~~Chemical admixtures shall conform to the requirements of ASTM Standard C494 and shall be accepted by the Consultant. All chemical admixtures must be suitable for use in precast concrete, be supplied by the same manufacturer as the air entrainment agent, and be compatible with each other. C494.~~

The addition of calcium chloride, retarders, accelerators or set controlling admixtures and air reducing agents will not be permitted.

~~Acceptable admixtures are air-entraining agents, superplasticizers and water-reducing agents.~~

~~7.2.4.5~~ ~~7.2.4.7~~ ~~7.2.4.7~~ Concrete

Concrete shall consist of hydraulic cement, condensed silica fume, coarse and fine aggregates, water and acceptable admixtures. ~~The type of concrete to be used~~ Concrete strength requirements will be specified on the Drawings.

10% silica fume by weight of cement ( $\pm 0.5\%$ ) shall be used in all precast concrete.

Air content shall be in accordance with CSA A23.1 Table 4, based on the maximum aggregate size used.

The ~~density, entrained air and~~ maximum air void spacing ~~requirements for the various types of hardened~~ concrete are specified in Table 7.1 shall be 230  $\mu\text{m}$ .

**Table 7.1**

<b>Type of Concrete</b>	<b>Aggregates</b>	<b>Concrete Unit Weight (in plastic state) kg/m<sup>3</sup></b>	<b>Minimum Entrained Air %</b>	<b>Maximum Air Void Spacing (hardened concrete) mm</b>
<del>Standard Weight</del>	<del>Fine and Coarse Standard Weight</del>	<del>--</del>	<del>5</del>	<del>0.23</del>
<del>Lightweight</del>	<del>Fine and Coarse Lightweight</del>	<del>1680 <math>\pm</math> 5%</del>	<del>6</del>	<del>0.23</del>
<del>Semi-Lightweight</del>	<del>Fine Standard Weight &amp; Coarse</del>	<del>1920 <math>\pm</math> 5%</del>	<del>6</del>	<del>0.23</del>

	<b>Lightweight</b>		
--	--------------------	--	--

~~7.2.4.6~~ ~~7.2.4.8~~ **7.2.4.8** Reinforcing Steel

Reinforcing steel shall conform to ~~the Bridge Construction Specifications~~ Section 5-~~1~~, Reinforcing Steel.

~~7.2.4.9~~ ~~Stressing Strand~~~~7.2.4.9~~ ~~Stressing~~ **7.2.4.9** ~~Stressing~~ Prestressing Strand

**Prestressing** strand shall be uncoated Grade 1860, low relaxation 7-wire strand conforming to the requirements of the ASTM ~~Standard~~ A416. Shop drawings and stressing calculations shall clearly show the type of strand to be used, and changes will not be allowed during production.

~~7.2.4.7~~ ~~7.2.4.10~~ ~~7.2.4.10~~ ~~Lifting Hooks~~

~~Prestressing strand used for fabricating~~ lifting hooks ~~made of stressing strand~~ shall conform to the requirements of the ASTM ~~Standard~~ A416, and shall be fabricated in a manner that distributes the load evenly to all strands.

~~7.2.4.8~~ ~~7.2.4.11~~ ~~7.2.4.11~~ ~~Miscellaneous Steel, Steel Diaphragms and Fasteners~~

Miscellaneous steel shall conform to the requirements of ~~the CSA Standard CAN/CSA G40.21M- Grade~~ 300W or ASTM ~~Standard~~ A36 or as specified on the Drawings. ~~The Consultant may request the Contractor to provide mill certificates to prove conformance to the standard. Fabrication~~ Steel diaphragm bracing members shall conform to CSA G40.21M Grade 300W or 350W. Steel with a boron content exceeding 0.0008% will not be permitted.

High strength bolts shall conform to the requirements of ASTM F3125 Grade A325/A325M heavy hex style. Rotational capacity testing is mandatory and shall be performed in accordance with ASTM F3125. A report meeting the rotational capacity test report requirements of ASTM F3125 Annex A2 shall be submitted to the Consultant for review and acceptance. Nuts shall be heavy hex style and shall conform to ASTM A563/A563M. Hardened washers shall conform to ASTM F436/F436M.

High strength bolts installed between steel components shall be tightened by the Bridge Construction Specifications ~~turn of nut method in accordance with Subsection 6.3.2.6, High Tensile Strength Bolted Connections.~~ All steel related fabrication shall conform to the requirements of Section 6-~~1~~ Structural Steel and these specifications.

~~7.2.4.12~~ ~~Anchor Rods for~~ **7.2.4.12** ~~Anchor Rods for~~ Bridgerail ~~and Anchor Bolts~~

7.2.4.12 Bolts

Anchor Rods for bridgerail anchor assemblies shall ~~be as per section 12.2.4.2 of The Specifications for Bridge Construction. The assemblies shall meet the requirements of Subsection 12.2.4.2, Anchor Rods and~~ be hot dip galvanized after fabrication. All nuts and washers shall be shop assembled on the anchor ~~bolts~~rods.

~~7.2.4.9~~7.2.4.13 ~~7.2.4.13~~ Voids, Ducts, and Ducts/Conduit

All Details of all proposed void and duct material must be accepted by and conduit materials shall be submitted to the Consultant and for review and acceptance in accordance with Subsection 7.2.3.4, Product Data Sheets.

All voids, ducts, and conduits shall remain dimensionally stable during the casting and steaming of the precast concrete units. Voids shorter than 400 mm ~~should~~shall not be ~~eliminated except when used unless~~ noted ~~otherwise~~ on the Drawings.

~~7.2.4.14~~ Post-Tensioning ducts shall be corrugated, semi-rigid galvanized metal tubes and be capable of withstanding concrete pressures without excessive deformation or permitting the entrance of the cement paste during the placement of concrete. The ducts shall have sufficient rigidity to maintain the required profile between points of support. The interval between supports shall not exceed 1.0 m.

~~7.2.4.10~~7.2.4.14 Bearings

Bearings shall be in accordance with Section 8, ~~of the Specifications for Bridge Construction.~~ Bearings.

~~7.2.4.11~~7.2.4.15 ~~7.2.4.15~~ Galvanizing

The fabricator shall provide a smooth finish on all edges and surfaces, and remove all weld spatters, and all welding flux residue from the steel components prior to galvanizing.

Factors contributing to galvanization-induced cracking shall be minimized. Galvanizing shall be by the hot dip method, after fabrication, in accordance with the current edition of ASTM A123/A123M Standard Specification for Zinc (Hot-Dip Galvanized) Coatings on Iron and Steel Products and ASTM F2329 Standard Specification for Zinc Coating Hot-Dip Requirements for Application to Carbon and Alloy Steel Bolts, Screws, Washers, Nuts, and Special Threaded Fasteners ~~with additions and exceptions as described in this specification. The fabricator shall provide a smooth finish on all edges and surfaces, and remove all weld spatters and all welding flux residue from the steel components prior to galvanizing and as modified in this specification.~~

The cleaning and pickling procedure of high strength ASTM A193 Grade B7 anchor rods shall be modified as follows prior to hot-dip galvanizing:

- Brush blast to remove mill scale and oil after threading ends;
- Flash pickle up to 5 minutes; and
- Quick dry prior to hot-dip galvanizing (not stored in flux or acid rinse).

The modified anchor rod cleaning and pickling procedure shall be completed in the presence of the Consultant prior to hot-dip galvanizing.

~~Repair of galvanizing shall only be done if bare areas are infrequent, small and suitable for repair. A detailed repair procedure shall be submitted for review prior to its use. It should be noted that completed~~ Repairs may require complete removal of the galvanized coating and re-galvanizing. Repair shall be in compliance with accordance ASTM A780, Method A3 "Metallizing". ~~However repair for-~~ and will only be permitted when the repair areas are small and infrequent as determined by the Consultant. Repair areas not exceeding less than 100 mm<sup>2</sup> in area may be done completed in accordance with ASTM A780, Method A1 "Repair Using Zinc-Based Alloy". The thickness of the coating for both methods shall be 180 µm, and the repair tested for adhesion. A detailed repair procedure shall be submitted for review and acceptance by the Consultant prior to commencement of the work. Repairs may require complete removal of the galvanized coating and re-galvanizing. The finished appearance shall be similar to the adjacent galvanizing. ~~as determined by the Consultant will determine the acceptability of repaired areas.~~

7.2.5—Galvanized material shall be stacked or bundled and stored to prevent wet storage stain as per the American Hot Dip Galvanizers Association (AHDGA) publication "Wet Storage Stain". Any evidence of wet storage stain shall be removed to the satisfaction of the Consultant.

Galvanized contact surfaces of bolted connections shall be hand wire brushed to a Class A slip coefficient surface condition. Slip coefficients surface conditions shall meet the requirements of Table 10.9 of CSA S6.

## 7.2.5 Manufacture

### ~~7.2.5.1 Forms~~

### 7.2.5.1 Forms

Precast concrete units are to be ~~manufactured~~fabricated in steel forms which are acceptable to the Consultant.

For all beam members the forms shall be designed to be removed without damaging the beam. For all "I" or "T" Beam members the side forms shall be designed to be removed without damaging the top flange of the beam. The forms shall be removed horizontally away from the beam by a method that prevents any contact of the form with the top flange after release of the form. The top flange shall not be subjected to a vertical force at any time.

Holes or voids cast into the top flange of "I" or "T" girders to accommodate deck formwork will not be permitted.

### ~~7.2.5.1~~7.2.5.2 Reinforcing Steel

Fabrication, handling, storage, ~~placement~~ and fastening of all steel reinforcement shall conform to ~~the Bridge Construction Specifications—Section 5—~~Reinforcing Steel.



Reinforcing steel-

Reinforcement placing tolerances shall be ~~placed, secured and~~ in accordance with Subsection 7.2.5.4, Void, Duct, Conduit and Reinforcement Placing Tolerances.

The Contractor shall place and fasten the reinforcement and have the Work inspected ~~for acceptance and accepted~~ by the Consultant prior to placement of concrete.

~~7.2.5.3 Stressing Strand~~

7.2.5.3 Stressing Prestressing Strand

Placement of prestressing strand and post tensioning ducts shall be in accordance with Subsection 7.2.5.4, Void, Duct, Conduit and Reinforcement Placing Tolerances.

Prestressing strand shall be free of corrosion, dirt, grease, rust, oil or other foreign material that may impede bond between the steel and the concrete. ~~Stressing Prestressing~~ strand shall be protected at all times ~~from during~~ manufacture through to encasing in concrete or ~~grouting. Stressing grout.~~ Prestressing strand that has sustained physical damage at any time shall be rejected. ~~Stressing Prestressing~~ strand splices shall not be placed within a precast concrete unit.

The Contractor shall submit for review the methods, procedures and devices to accurately position the ~~stressing prestressing~~ strand. The submission shall include strand anchorage, draping, hold downs, guides or any other required devices.

~~Stressing Prestressing~~ strands shall not be stressed more than 36 hours prior to being encased in concrete. The force in each prestressing strand shall be measured by both elongation and pressure gauge.

Each prestressing strand shall be stressed to a calculated elongation, and a gauge pressure reading shall be taken as a check against the calculated force. During stressing, each prestressing strand shall ~~be first be~~ pulled to a predetermined pre-pull gauge pressure to eliminate any slack and a reference mark be placed on the prestressing strand at the front of the stressing jack. A second mark shall be placed on the prestressing strand away from the first with a distance corresponding to the calculated elongation on the stressing sheet. Each prestressing strand shall then be pulled to the second reference mark and the gauge pressure reading taken.

This process may be reversed, i.e. each prestressing strand shall be stressed to a calculated force (Determined by a gauge pressure calibration chart) and the elongation shall be measured as a check against the calculated force. During stressing, each prestressing strand shall ~~be first be~~ pulled to a predetermined pre-pull gauge pressure to eliminate any slack and a reference mark be placed on the prestressing strand at the front of the stressing jack. Each prestressing strand shall then be stressed to the gauge pressure corresponding to the stressing sheet and a second reference mark be placed on the prestressing strand at this gauge pressure. The elongation shall be the distance measured between the two reference marks.

~~The maximum allowable discrepancy between jack pressure~~At the completion of tensioning, the two control measurements, force and elongation, shall be within meet the verification requirements of Subsection 5%, or the factors contributing to the difference must be identified and corrected before proceeding. 2.2, Tensioning of Tendons, of the PCI Quality Control Manual MNL-116.

Changes in prestressing strand temperature and slippage at prestressing strand anchorages shall be measured between stressing and concrete encasement and any changes in prestressing strand stress due to these effects shall be accounted for in the design. The stressing procedure and stressing calculations shall be submitted for review by the Consultant.

~~Seven-wire stressing~~Prestressing strand with any broken or damaged wire shall be removed and replaced. All ~~stressing~~prestressing strands shall be checked for wire breaks and damage before placement of concrete. Prestressing strand damage includes nicks, gouges, and indentations.

The precast concrete unit ends shall have 15 mm deep prestressing strand termination recesses formed around the strands. All prestressing strands shall be cut flush with the bottom of the recesses, and the recesses shall then be filled flush with the ends of the girders with a moisture insensitive epoxy paste adhesive meeting the requirements of ASTM C881, Type IV, Grade 3, Class B or C. The paste shall be grey in colour. An approved Type 1c sealer shall be applied over the patched recessed areas as per Subsection ~~7.2.5.14~~7.2.5.14, Type 1c Sealer. Sealer shall not be applied to the patched recessed areas when precast concrete unit ends are designed to be encased in field cast concrete.

#### ~~7.2.5.4 Void and Duct Placement~~

#### 7.2.5.4 Void, Duct, Conduit and Reinforcement Placing Tolerances

Voids ~~and~~, ducts, and conduits shall be placed as shown on the Drawings and must be tied and securely held in the required positions to prevent movement. Continuous ducts shall align precisely. The ends of the voids shall be sealed by methods accepted by the Consultant. Voids found to be distorted, damaged or of insufficient strength will be rejected. Blow holes caused by air expanding within the voids and rising to the surface, shall be repaired when the concrete is in the plastic state.

7.2. Reinforcing steel, prestressing strand, and post-tensioning ducts for precast concrete shall be placed within the following tolerances:

- Concrete cover:  $\pm 5$  mm;
- Vertical position of prestressing strand:  $\pm 5$  mm;
- Post-tensioning ducts:  $\pm 10$  mm, except  $\pm 5$  mm at splice points;
- Length of debond on prestressing strand:  $\pm 50$  mm;
- Stirrup spacing:
  - When spacing is 100 mm or less:  $\pm 15$  mm;
  - When spacing is greater than 100:  $\pm 25$  mm;
  - When spacing is 300 mm or greater:  $\pm 30$  mm;

- Location, where the smallest dimension of the element is:
  - 400 mm or less:  $\pm 8$  mm;
  - Larger than 400 mm but less than 800 mm:  $\pm 12$  mm;
  - 800 mm or larger:  $\pm 20$  mm;
- Longitudinal locations and ends of bars, except at ends or edges of elements:  $\pm 50$  mm;  
and
- Longitudinal location of ends of bars at ends or edges of elements:  $\pm 20$  mm.

The clear distance between reinforcement shall not be less than 1.5 times the nominal diameter of the reinforcement, 1.5 times the maximum coarse aggregate size, or 40 mm.

#### ~~7.2.5.2~~ 7.2.5.5 Identification of Precast Concrete Units

The fabricator's name, year of manufacture, unit serial number and design loading shall be cast into the bottom of the precast concrete units in 50 mm letters ~~about~~approximately 1.0 m from the precast concrete unit end.

#### ~~7.2.5.3~~ 7.2.5.6 ~~7.2.5.6~~ Concrete Measuring, Mixing and Placing

The procedures outlined in ~~the~~ ACI Standard 304 "Guide for Measuring, Mixing, Transporting and Placing Concrete" shall be followed. The time from initial mixing of the concrete until placing the concrete in the forms shall not exceed one hour. The ~~elapsed time between the successive placing rate~~ of concrete ~~onto previously placed concrete placement~~ shall be such that cold joints do not exceed 45 minutes occur.

#### ~~7.2.5.4~~ 7.2.5.7 ~~7.2.5.7~~ Concrete Temperature

The concrete temperature shall be between 10 °C and 30 °C at the time of placing in the forms.

#### ~~7.2.5.5~~ 7.2.5.8 ~~7.2.5.8~~ Finished Riding Surface

Where the top surface of the girder is designed to be the riding surface, the use of a continuous screed rail, independent of the top of the grout keys, shall be ~~employed~~used. The top surface shall follow a smooth profile, which incorporates the required camber adjustments.

#### ~~7.2.5.6~~ 7.2.5.9 ~~7.2.5.9~~ Camber Hubs

Three camber hubs shall be placed in each girder, located along the centerline of the girder at the ~~midpoint~~midspan and 150 mm from each end. The camber hubs shall consist of 10 mm galvanized bars, of sufficient length to project vertically 10 mm above the ~~riding girder top~~ surface.

The Contractor shall store the members in such a manner as to provide access for measuring camber as determined by the Consultant. The Contractor shall provide personnel as requested to assist the Consultant with the camber readings. The Contractor shall record the girder camber at the ~~midpoint~~midspan of each girder within 24 hours of girder destressing.

~~7.2.5.7.7.2.5.10~~ ~~7.2.5.10~~ Concrete Finish

The exposed face of exterior ~~concrete girder faces~~girders shall have a Class 2 rubbed surface finish, unless specified otherwise. Except the top, all the remaining surfaces shall have a Class 1 ~~Form~~Ordinary surface finish.

~~7.2.5.7.17.2.5.10.1~~ (a) Class 1 ~~Form~~Ordinary Surface Finish

7.2.5.10.1.1 Unformed Surfaces

Immediately following placing and consolidation, the concrete shall be screeded to conform to the required surface elevations, and then trowelled to ensure that the surface is free from open texturing, plucked aggregate, and local projections or depressions.

Concrete surfaces shall be such that when checked with a 1.2 m long straight edge placed anywhere in any direction on the surface, there shall not be any gap greater than 3 mm between the bottom of the straight edge and the concrete surface unless otherwise specified.

7.2.5.10.1.2 Formed Surfaces

This finish is essentially that obtained when concrete has been cast and adequately compacted in a properly oiled steel form. All fins, honeycomb, irregularities, cavities over 10 mm diameter or other similar defects shall be thoroughly chipped out. These areas shall be saturated with water for a period of not less than thirty minutes, carefully pointed and trued with mortar of a colour which will match the existing concrete. Mortar used for pointing shall be less than one hour old. The patches shall be properly cured by placing the repaired precast concrete unit in the steam cure for a period of four days immediately after patching.

The finished surfaces shall be true and uniform. All surfaces which cannot be repaired to the satisfaction of the Consultant shall be finished as specified for Class 2 at no expense to the Department.

~~7.2.5.7.27.2.5.10.2~~ (b) — Class 2 Rubbed Surface Finish

Class 2 Finish shall be essentially the same as Class 1 except that all holes, cavities and defects shall be repaired so that the finished surface presents a smooth, true, dense, uniformly coloured, and non-stained appearance. The concrete surfaces shall be thoroughly ~~wire brushed to expose any hole or cavity prior to repairs. All residue of form oil shall be removed from the surface exposed by brush abrasive blasting to expose any hole or cavity prior to repairs.~~ Surface voids greater than 19 mm diameter but less than or equal to 0.05 m<sup>2</sup> in area and less than or equal to 30 mm deep shall be filled with an Department approved concrete patching material listed on the Department's Product list in the Overhead/Vertical (OH-V) category and placed in accordance with the manufacturer's published product data sheet. Surface voids less than 19 mm in diameter and less than or equal to 30 mm deep may be filled with a pre-bagged sack rub material. Sack rub materials shall be placed over the entire prepared surface in accordance with the manufacturer's recommendations. Both sack rub and patching materials shall be wet cured for a minimum of 72 hours if applied after curing of the precast concrete unit. When the patching and sack rub materials have adequately cured, a carborundum stone or method acceptable to the Consultant shall be used to finish the surface to a smooth, uniform and closed texture. Any voids or cavities opened during the stone rubbing process shall be re filled. Parging or surface patching to correct irregularities will not be permitted.

~~(c) — All of the prepared concrete surfaces, including all patching and sack rubbing shall be uniform in colour and texture. All residue of form oil shall be removed from the surface.~~

~~7.2.5.7.37.2.5.10.3~~ Class 3 Bonded Concrete Surface Finish

The surface shall be prepared in accordance with the requirements of Class 2 Rubbed Finish except that it need not be of uniform colour. After the surface preparation has been completed to the satisfaction of the Consultant, the surface shall be pressure washed to remove all dust, dirt, laitance and all other bond breaking materials. After the concrete surface has dried for a minimum of 24 hours, the Contractor shall then supply and apply an approved pigmented sealer, which meets the requirements for a Type 3 sealer of the Material Testing Specifications for Concrete Sealer - B388.

The pigmented sealer shall be applied in accordance with the manufacturer's specifications. The colour(s) of the proposed coating scheme, which typically shall be similar to the natural colour of cured concrete, must be acceptable to the Consultant before application of the coating. A minimum of two applications of the pigmented sealer are required. When spray application is used the surface shall be back rolled. The Contractor shall ensure that no colour variation is visible and shall match the colour of any previously ~~painted~~ sealed adjoining surfaces. Acceptance of the pigmented sealer used will not be considered to relieve the Contractor of full responsibility for its acceptable performance and appearance.

~~7.2.5.7.47.2.5.10.4~~ (d) — Class 4 Floated Surface Finish

After the concrete has been consolidated and the surface carefully screeded to the cross section and profile shown on the Drawings, it shall be floated and trowelled as necessary to provide a closed, uniformly textured surface without brooming.

~~7.2.5.7.57.2.5.10.5~~ (e) — Class 5 Floated Surface Finish, Broomed Texture

After the concrete has been consolidated, the surface shall be carefully screeded to the cross section and profile shown on the Drawings. When the concrete has hardened sufficiently, the surface shall be finished with a broom of an accepted type. The broom strokes shall be perpendicular to the edge of the precast concrete unit, and extended from edge to edge, with adjacent strokes slightly overlapped producing corrugations of 2 to 3 mm in depth. Brooming shall be done when the concrete has set sufficiently to produce clear, crisp brooming marks which do not sag or slump, without tearing the surface or disturbing coarse aggregate particles. After final brooming the surface finish shall be free of porous spots, irregularities, depressions, pockets and rough spots and must not vary more than 5 mm when measured using a 3 m straight edge.

Accepted finishing and edging tools shall be used on all edges and expansion joints after brooming.

~~7.2.5.11~~ Curing

~~7.2.5.11~~ Curing

All ~~prestressed~~precast concrete units shall be cured at an elevated temperature. The curing of ~~prestressed~~precast concrete units shall essentially be in accordance with CSA A23.4 unless otherwise specified. The ambient curing temperature shall be increased at a rate not exceeding 20 °C per hour until a maximum temperature of not more than 60 °C is attained. After curing, the temperature of the precast concrete units shall be reduced at a rate not exceeding 10 °C per hour until the temperature of the concrete has fallen to within 10 °C of the ambient air temperature ~~of the~~ outside air~~the enclosure~~.

The Contractor shall record and provide “In the Form” and “After Removal from Form” curing data including ramp-up and ramp-down temperature changes to the Consultant. The Alberta Transportation bridge file number, precast concrete unit serial number, casting date, curing start date, additional curing days due to non-compliant days, and curing completion date shall be identified on the curing data submitted. A coloured graph documenting Time-Temperature-Humidity data throughout the curing phase shall be submitted as part of the curing data.

Care must be exercised to protect ~~prestressed and non-prestressed~~precast concrete units from thermal shock at all times until these precast concrete units have been fully cured.

Two continuously recording thermometers and two continuously recording hygrometers shall be provided for each curing enclosure to monitor the concrete ambient temperature and relative humidity. All time-temperature and time-humidity recordings shall be clearly shown on the graph.

~~7.2.5.7.6~~7.2.5.11.1 (a) — Prestressed Precast Concrete Units

~~7.2.5.7.6~~7.2.5.11.1.1 (i) — Curing in the Form

The initial application of heat shall commence only after the last of the freshly placed concrete has attained its initial set, normally ~~two~~2 to ~~four~~4 hours after casting. Heat shall not be applied directly to the concrete, but by a method that will produce a consistent ambient temperature throughout the entire form and enclosure. The increase in temperature and the holding temperature shall be monitored and permanently recorded on a chart at a minimum of 3 quarter points along the form.

~~7.2.5.7.6~~7.2.5.11.1.2 (ii) — ~~Steam~~ Curing after Removal from the Form

Upon removal from the forms the precast concrete units shall be cleaned, patched, and finished within a period not exceeding 12 hours. The precast concrete units shall be placed in a manner that will facilitate any clean up or repair work, and that will allow full inspection of all surfaces. Within 24 hours of removal from the form, the precast concrete units shall be placed within a suitable enclosure, for curing.

The curing enclosure shall provide a minimum of 150 mm of free air space between the concrete surfaces and the coverings. Flexible coverings shall be secured to prevent any moisture loss.

The difference in ambient air temperature adjacent to the concrete at different locations within the enclosure shall not exceed 10 °C at any time.

The curing process shall be continued for a period of four days with one of the following methods:

1) ~~1)~~ — Steam Curing

Steam jets shall not directly impinge on the concrete surfaces. The steam must be in a saturated condition maintaining an atmosphere of 95% to 100% relative humidity and a uniform ambient temperature of 40 °C to 60 °C.

For days with periods of 4 or more hours within a 24 hour period, where measured temperature or humidity levels do not meet the required limits, these days will not be counted as a full day of steam cure. An additional day of steam cure beyond the specified 4 days will be required for each non-compliant day.

2) ~~2)~~ Curing with Continuous Misting and Heat

Sufficient number of atomizing misting nozzles shall be strategically located to produce a fine mist with 95% to 100% relative humidity in the enclosure. The water shall be preheated to a temperature which will produce a misting temperature compatible with the ambient temperature, inside the enclosure. The enclosure shall be heated with radiant heaters to a temperature of 40 °C to 60 °C. Dry heat shall never touch the concrete surface at any time. A control system shall be installed to shut off the heat when the humidity level drops below ~~90~~95% in the enclosure. Should the temperature in the concrete rise above 40 °C without the misting, the precast unit will be rejected.

~~Two continuously recording thermometers and two continuously recording hygrometers are to be provided for each curing enclosure to monitor the concrete ambient temperature and relative humidity. All time temperature and time humidity recordings shall be clearly shown on the graph.~~

7.2.5.7.7.2.5.11.2 ~~(b)~~ Non-Prestressed Precast Concrete Units

Curing of all non-prestressed precast concrete units shall be in accordance with one of the following methods:

7.2.5.7.7.47.2.5.11.2.1 ~~(i)~~ Elevated Temperature Curing

~~Upon removal from the forms the~~ The precast concrete units shall be cleaned, patched, finished and ~~elevated temperature then~~ cured ~~for four days as per section 7.2.5.11(a) "Prestressed Concrete"~~ in accordance with Subsection 7.2.5.11.1, Prestressed Precast Concrete Units.

7.2.5.7.7.27.2.5.11.2.2 ~~(ii)~~ Moist Curing

The precast concrete units may be moist cured in lieu of elevated temperature curing in accordance with the following:

Upon removal from the forms the precast concrete units shall be cleaned, patched, finished, and ready for inspection within a period not exceeding 12 hours. Patching shall be performed with an approved product and at an ambient temperature of ~~15~~10 °C to ~~30~~25 °C. After completion of patching and finishing, within 24 hours of removal from the form, the precast concrete units shall be placed under two layers of light ~~colored~~coloured filter fabric at an ambient temperature of not less than 15 °C. The filter fabric or burlap shall be kept in a continuously wet condition throughout the curing period by means of a soaker hose or other means as reviewed and accepted by the ~~Department~~Consultant. Curing with filter fabric or burlap and water shall be maintained for a minimum period of seven days.

7.2.5.87.2.5.12 ~~7.2.5.12~~ Release of Stressing/Prestressing Strand

The stressing/prestressing strand shall not be released until the specified concrete release strength is attained, and the release shall be in accordance with the accepted sequence.



Evidence of casting defects shall be reported to the Consultant prior to release of the prestressing strands.

~~7.2.5.9.7.2.5.13~~ ~~7.2.5.13~~ — Repairing ~~Damaged~~ Concrete Defects

~~Serious damage, honeycomb~~ Honeycomb, cavities, spalls, chips, cracking and other ~~casting~~ defects shall be immediately reported to the ~~Department and~~ Consultant.

Repair procedures shall be developed by a Professional Engineer and submitted for review and acceptance by the Department and the Consultant prior to the commencement of the repair. All repairs shall be completed prior to curing of the precast concrete unit at an ambient temperature ~~of between~~ 15 °C to and 30 °C. Depending on the size and location of the defect, repairs may be required before or after girder de-stressing as outlined in this specification. Damaged concrete shall be repaired by the Contractor at his expense to the satisfaction of the Consultant. Precast concrete units shall be protected from dehydrating by maintaining a saturated surface dry condition during the implementation of any approved repair procedures.

~~Repairs to defects such as cracks, honeycombs or spalls shall be carried out in accordance with this section. Any unacceptable cracks, honeycombs or spalls will result in rejection of the unit.~~

~~In this section the “The bearing area” of an NU girder is defined as the portion of the girder bottom flange up to the underside, but not including the radius transition between the bottom flange and the web, directly above the bearing. The bearing area extends extending from the end of the precast concrete unit to 75 mm beyond the edge of the shoe plate.~~

The bearing area of a SL/SLW/SLC girder is defined as the thickness of the bottom soffit or 145 mm, whichever is greater, extending 500 mm from the end of the precast concrete unit.

The “anchorage area” of a girder is defined as the full height portion of the girder that is two times the girder depth from the end of the girder but is not in the bearing area.

~~7.2.5.9.17.2.5.13.1~~ ~~(a)~~ — Cracks

The following cracks are unacceptable and ~~may~~ will result in rejection of the precast concrete unit unless reviewed and accepted by the Consultant and the Department:

- Cracks in the bearing area of a girder;
- Cracks in the anchorage area of a girder exceeding 0.5 mm in width; or longer than 300 mm; and
- Cracks outside of the girder bearing and anchorage areas exceeding 0.2 mm in width or longer than 300 mm.

All repairable cracks less than 0.2 mm in width shall receive two coats of a type 1c sealer unless the crack will be fully encased in a cast-in-place concrete diaphragm or the precast concrete unit requires a Class 3 finish on the surface where the crack is present.

All repairable cracks 0.2 mm or greater in width shall be repaired by epoxy injection in accordance with the epoxy manufacturer's instructions. The epoxy resin shall meet the requirements of ASTM C881 Type IV, Grade 1, Class B or C and have a viscosity less than 500 cP. An injection procedure shall be submitted by the Contractor to the Consultant for review and acceptance prior to commencing repairs. Coring shall be carried out to confirm the penetration of the epoxy into the cracks if requested by the Department.

The Contractor shall immediately notify the Department and the Consultant, if a crack that has a potential to be a shear crack exceeds 0.15 mm in width and longer than 0.25 times the girder depth. Crack length shall be measured along the horizontal axis and a crack will be considered to be a shear crack if inclined at an angle between 30° and 60° from horizontal.

~~7.2.5.9.27.2.5.13.2~~ (b) — Honeycombs and Spalls

The following conditions of honeycomb or spall are unacceptable and may will result in rejection of the precast concrete unit unless ~~accepted and signed off by the Design Engineer and reviewed and accepted~~ by the Consultant and the Department:

- ~~Any honeycomb or spall in the bearing or anchorage areas of the girder~~
- ~~Major honeycomb; or spall in areas outside the bearing and anchorage areas of a girder. Major honeycombs and spalls are described as honeycombs and~~
- Honeycombs or spalls that are more than 30 mm deep or more than 0.405 m<sup>2</sup> in area located outside the bearing and anchorage areas of a girder.

When accepted by the Consultant and the Department, ~~repairs~~ the Contractor's proposed repair procedure for honeycombs and spalls ~~may be made using shall as a cementitious minimum, include removing and replacing the defective concrete with the originally specified class of concrete. Repair extents shall be saw cut 20 mm deep in neat perpendicular lines and concrete removed to a depth of 20 mm below reinforcing and prestressing strand. Repair areas shall be roughened to remove all loose material. Repairs of minor honeycombs and spalls may be made after distressing of the girder. However major honeycombs and spalls shall be repaired to its original condition. Repair areas shall be saturated with water prior to concrete placement. Repair areas shall be free of standing water and surface dry immediately prior to concrete placement. Repairs shall be completed before girder distressing.~~

Honeycombs or spalls less than or equal to 0.05 m<sup>2</sup> in area or 30 mm in depth, shall be repaired in accordance with Subsection 7.2.5.10.2, Class 2 Rubbed Surface Finish and may be completed after girder distressing the girder.

~~7.2.5.107.2.5.14~~ 7.2.5.14 — Type 1c Sealer

The Contractor shall supply and apply an approved Type 1c sealer to the girder surfaces as shown on Standard Drawing S-1637 "Type 1c Sealer for Precast Girders". Drawings S-1851, Standard Concrete Sealer Surface Treatment for Major Bridge and S-1852, Standard Concrete Sealer Surface Treatment for Standard Bridges.

Type 1c sealers shall meet the current Material Testing Specifications for Concrete Sealers - B388.

The sealer shall be applied on clean dry surfaces free of form oil, and in accordance with the manufacturer's recommendations however the application rate shall be increased by 30% from that indicated on the approved list-products list and the substrate temperature shall be a minimum of 5 °C. Before applying the sealer the concrete shall be cured for at least 14 days. Mortar patches shall be cured for at least two a minimum of 2 days. The concrete surface shall be dry, and air blasted to remove all dust and accepted by the Consultant prior to applying sealer. In order to ensure uniform and sufficient coverage rates the Contractor shall apply measured volumes of sealing compound to appropriately dimensioned areas of concrete surface, using a minimum of 2 coats.

The Contractor shall ensure that the sealer is not applied in the grout pockets, lifting hook pockets or areas of the girders that will have field concrete cast against them. The Consultant reserves the right to sample and test the sealer supplied by the Contractor.

~~The Consultant reserves the right to sample and test the sealer supplied by the Contractor.~~

~~7.2.5.14~~ 7.2.5.15 ~~7.2.5.15~~ Sandblasting

The roughening of concrete surfaces in shear key, block out, diaphragm and girder end void locations shall be achieved by sandblasting or other acceptable methods proposed by the Contractor ~~to the acceptance of and reviewed and accepted by~~ the Consultant. The roughening shall be sufficient to remove all laitance and uniformly expose the aggregate particles.

~~7.2.5.12~~ 7.2.5.16 ~~7.2.5.16~~ Dimensional Tolerances of ~~Cast Units~~ Precast Concrete Units

The maximum dimensional deviation in mm, of cast precast concrete units from that as detailed specified on the Drawings shall not exceed the following:

- Length: ± 20 mm x length (m) ) ± 50;
- Width: ± 3 mm;
- Depth: ± 5 mm;
- Camber: ± 20 mm x length (m) ) ± 50;
- Sweep (NU Girders) ~~—————~~ ); 1 mm/m;
- Sweep (Other Units) ~~—————~~ ); deviation from true, 20 mm x length (m) ) ± 50;
- Projection of Stirrups from Top of Girder: ± 12 mm;
- Bearing Areas: out of flatness of bearing areas, 3 mm;
- Bulkheads: warpage or tilt of ends, 5 mm;
- Rail Anchor Bolts: out of line, 5 mm; in spacing, 5 mm; in projection, 5 mm;
- Dowel Holes: out of plumb, 5 mm; and
- Void Location: surface to void dimension, ±15 mm after casting.

~~7.2.5.17~~ ~~Handling and Storage~~ Dimensional tolerances for sweep shall be measured immediately prior to shipping to the project site.

~~7.2.5.13~~ 7.2.5.17 Handling and Storage

Precast concrete units shall be handled by means of ~~accepted~~ lifting devices which have been reviewed and accepted by the Consultant and at the designated locations. Precast concrete units shall be maintained in an upright position, supported near the ends and on stable foundations.

7.2.6 ~~7.2.6~~ Testing and Inspection

~~7.2.6.1~~ Access

7.2.6.1 Access

The Contractor shall provide ~~the full facilities for the inspection of Work. The Consultant with suitable and safe~~ shall have full access to all parts of the works for Work at all times. When required by the purposes of testing and inspection. Consultant, the Contractor shall provide ~~the following: needed manpower for assistance in checking layout and performing inspection duties.~~

- ~~(a) Heated laboratory space, minimum of 3 m x 3 m, capable of being locked, located in the proximity of the work~~
- ~~(b) A work bench 1 m x 3 m x 1 m high~~
- ~~(c) Cylinder storage chest with temperature control and a max/min thermometer, as per CSA Standard A23.2-3C~~
- ~~(d) A sump and a water supply suitable for cleaning all testing equipment~~
- ~~(e) A calibrated weigh scale.~~

~~7.2.6.2~~ Inspection

~~The Contractor shall be responsible for quality control. Inspection of the units by the Consultant will not relieve the Contractor of his responsibility for quality control.~~

~~The following stages of manufacturing require the Consultant's acceptance:~~

7.2.6.2 (a) Responsibility

It is the Contractor's responsibility to ensure that the Work is completed in accordance with the Contract requirements. Any inspection and/or testing completed by the Consultant, review and acceptance by the Consultant, shall not be considered as relieving the Contractor of the responsibility for completing the Work in accordance with the Contract.

7.2.6.3 Witness Points

Inspection stations shall be set up at specific points during the course of fabrication for the Consultant to complete inspection and/or testing. At each witness point the Work shall be checked by the Contractor, reviewed and accepted by the Consultant, and all deficiencies corrected to the full satisfaction of the Consultant prior to the next sequence of fabrication. Witness points for precast concrete units shall be:

- Form dimensions and set-up;
- ~~(b)~~ — Placement of reinforcing steel and prestressing strand;
- ~~(c)~~ — Placement of voids and hardware;
- ~~(d)~~ — Stressing;
- ~~(e)~~ — Concrete mixture and placement;
- ~~(f)~~ — Form stripping;
- ~~(g)~~ — Clean-up and repair;
- ~~(h)~~ — Finishing and application of sealer;
- ~~(i)~~ — Curing;
- ~~(j)~~ — Application of Class 3 concrete finishes; and
- ~~(k)~~ — Storage of precast concrete units.

7.2.6.3 Test Methods7.2.6.4 Testing by the Contractor

Sampling, ~~making~~ casting, curing and testing concrete specimens shall be completed by the Contractor in accordance with the requirements of the following CSA standards:

- ~~—~~ Sampling - A23.2-1C;
- ~~—~~ Concrete Test Cylinders - A23.2-3C;
- ~~—~~ Testing Concrete Cylinders - A23.2-9C;
- ~~—~~ Air Content - A23.2-4C;
- ~~—~~ Density of Concrete - A23.2-6C; and
- ~~—~~ Air Void Determination - A23.2-17C.

7.2.6.4 The Contractor's testing and inspection records shall be open for examination by the Consultant upon request.

Testing, inspection and related costs incurred by the Consultant resulting from defective work or ~~Testing by the Contractor~~ Contractor proposed details not specified on the Drawings shall be paid for by the Contractor.

~~The Contractor shall provide testing equipment, facilities and personnel to ensure that the concrete supply meets all requirements of the specifications. He shall maintain the required air entrainment by testing and making adjustments to the mix prior to and during the placing of concrete in the forms. The Consultant may test the air content to ensure that this is being correctly maintained however testing of concrete by the Consultant will not relieve the Contractor of his overall responsibility for quality control of the concrete.~~

7.2.6.5 Release Strength Test Cylinders

The Contractor shall make and ~~test~~complete concrete ~~cylinders~~cylinder strength testing to ~~prove~~determine that the required release strength as ~~stated~~specified on the ~~drawing~~Drawings has been ~~attained~~achieved prior to release of the ~~stressing~~prestressing strand.

When one or more precast concrete units are cast continuously, at ~~least~~minimum, two cylinders shall be taken ~~from that~~ represent the last precast concrete ~~of the last~~ unit ~~poured~~cast to represent the release strength for all precast concrete units. These strength test cylinders shall be cured with the bridge~~last precast concrete~~ unit cast. Only testing of the first cylinder will be ~~necessary if the~~ required if the specified release strength is ~~obtained~~achieved. In the event all cylinders are tested without the required strength being ~~obtained~~achieved, the Consultant shall ~~be contacted~~review and ~~his acceptance obtained for~~accept the timing of release ~~of the units~~.

7.2.6.6 28 Day Strength Testing

The Contractor shall ~~make~~cast concrete test cylinders to determine the 28-day strength. The Consultant will determine from which batch the test cylinders shall be taken. Samples for testing will be taken from the fresh concrete being placed in the forms at the rate of one set of cylinders for every three bridge~~precast concrete~~ units cast continuously. Additional cylinders may be cast at the discretion of the Consultant. A set shall consist of three cylinders. A strength test will be the average of the 28-day strengths of the three cylinders (one set). Continuous casting shall mean no break in the casting longer than one hour.

The Contractor shall be responsible for transporting the test cylinders to an independent CSA testing laboratory ~~certified to CSA A283~~. The transportation and testing of concrete test cylinders ~~will~~shall be at the Contractor's expense. These tests shall represent the strength of the cast concrete. Test results shall be forwarded to the Consultant within 24 hours of testing.

7.2.6.7 Notification to Ship

The Contractor shall notify the Consultant 72 hours prior to shipment to facilitate inspection and acceptance of the precast concrete units. Precast concrete units shall not be shipped until they have been reviewed and accepted by the Consultant. Review and acceptance of precast concrete units at the fabrication facility by the Consultant will not relieve the Contractor of his full responsibility to meet the requirements of these specifications.

Precast concrete units that have not been inspected at the fabrication facility will not be paid for until such material has been inspected, reviewed and accepted by the Consultant. The Contractor shall be responsible for all ~~travel, boarding and lodging~~ costs incurred by the Consultant ~~to inspect prestressed and for inspection of the~~ precast concrete ~~bridge~~ units ~~and miscellaneous precast~~ not inspected at the fabrication facility.

7.2.6.8 Fabrication Outside of Canada

All testing and inspection requirements specified in Subsection 7.2.6, Testing and Inspection, shall be completed at the fabrication facility and all costs incurred by the Consultant and their designated testing agencies, and the Department shall be paid for by the Contractor.

~~All components being fabricated outside the Province of Alberta. Also included Canada shall be the costs for shipped to a department representative to attend the prejob meeting and three additional site visits during the course of fabrication shop located in Canada that is certified by CPCI in the applicable Product Group classification of the component for re-inspection and testing. The components shall be in a condition that facilitates all testing and inspection requirements. Precast concrete units fabricated outside of Canada shall be re-inspected by a Prestressed/Precast Concrete Institute (PCI) certified level II inspector. Testing and inspection shall be completed in accordance Subsection 7.2.6, Testing and Inspection. The PCI certified inspector shall also inspect all components to ensure that they were not damaged during transportation.~~

#### ~~7.2.6.7— Fabrication of Prestressed/Precast Units in Cold Weather~~

~~The Contractor shall accept full responsibility for the protection of prestressed/precast concrete units when fabricating in adverse weather conditions.~~

~~When the ambient temperature is, or is expected to be, below 5°C during fabrication the following provisions for cold weather casting shall be put in place:~~

- ~~(a) The Contractor shall construct an enclosure capable of maintaining an ambient temperature within the structure of between 15°C and 30°C. The enclosure shall be sufficiently sized to accommodate steel forms, workers and the casting equipment. The enclosure temperature shall be constantly monitored and shall be maintained within the specific range.~~
- ~~(b) The heating system shall be designed to provide uniform distribution of heat and the combustion by-products shall be kept out of the enclosure.~~
- ~~(c) Before casting concrete, adequate preheat shall be provided to raise the temperature of the formwork, reinforcing steel, stressing strand, miscellaneous iron, etc. to at least 10°C.~~
- ~~(d) The fabricated units shall be kept in the enclosure until they are patched, repaired and transferred to the curing enclosure.~~

~~7.2.7— In addition three concrete cores shall be taken from each precast concrete unit, at locations determined by the Consultant, and tested by a laboratory certified to CSA A283 to determine that the concrete meets all Contract requirements.~~

~~Components shall not be shipped from the Canadian shop until all requirements have been met and the Work has been reviewed and accepted by the Consultant.~~

~~The Contractor shall be responsible for all re-inspection and testing costs, including all cost incurred by the Consultant and the Department.~~

~~The Contractor shall have no claim against the Department resulting from delays caused by these requirements.~~

## 7.2.7 Failure to Meet Strength Requirements

7.2.7.1 ~~7.2.7.1~~ Right of Rejection

The ~~Consultant~~Department reserves the right to reject ~~any~~ concrete ~~whatsoever which~~that does not meet the specified ~~strength determined in accordance with this Specification requirements.~~ The ~~Consultant~~Department may, ~~however,~~ at ~~his~~its sole discretion, accept ~~precast concrete which~~units that does not meet the specified ~~28 day concrete compressive strength at a reduced price.~~ Payment adjustment may be made in accordance with Subsection 7.2.7.3, Payment Adjustment Schedule.

7.2.7.2 ~~Coring~~strength requirements, and in such case

~~Coring to confirm or contest low concrete strength test results will only be permitted when reviewed and accepted by the Department. Sampling and testing of cores shall be completed by an independent laboratory certified to CSA A283 in accordance with CSA A23.2 14C. Cores shall be extracted in the presence of the Consultant and tested within 7 days of testing the cylinders being evaluated.~~

~~Three cores shall be extracted for each concrete strength test result being evaluated. Core locations will be determined by the Consultant. The core size shall be 100 mm diameter by 200 mm length or of a size acceptable to the Consultant. Core holes shall be repaired using a Department approved concrete patching product acceptable to the Consultant.~~

~~The average strength of each set of 3 cores from a precast unit will represent a concrete strength test and shall be equal to or greater than the specified strength. CSA A23.1, Clause 4.4.6.6.2.2, Acceptance of Cores Drilled from a Structure, shall not apply. If the average cored concrete strength is greater than the averaged cylinder concrete strength, the concrete cored strength result will be used as the basis for acceptance and payment will be made in accordance with section 7.2.7.2. If the averaged cored concrete strength is less than the averaged cylinder concrete strength, the averaged cylinder concrete strength will be used as the basis for acceptance and payment.~~

~~7.2.7.2 Percentage All costs associated with coring, testing, reporting and repairing core holes shall be at the Contractor's expense.~~

7.2.7.2.7.3 Payment ~~Adjustment~~ Schedule

When the specified 28-day concrete strength is not met, the precast ~~bridge~~concrete unit shall be paid ~~as per the following percentage of the unit price in accordance with Table 7-1, Payment Adjustment Schedule:~~

**Table 7-1: Payment Adjustment Schedule**

Strength below the specified 28-day strength	Percentage of Unit Price to be paid
1 MPa or less	95%



1 MPa to 2 MPa	90%
2 MPa to 3 MPa	85%
3 MPa to 4 MPa	80%

In the event that the concrete tested is more than 4 MPa below the specified 28-day strength, the bridge precast concrete units fabricated from the concrete represented by the test specimens shall be rejected. In the event that the precast concrete unit has been delivered and/or erected in the field, it shall be removed and returned to the Contractor's plant for replacement. The entire cost of replacement, including delivery and erection costs, shall be at the Contractor's expense.

### ~~7.2.7.3~~ Coring

~~If any concrete tested fails to meet the specified strength, the Contractor may request permission to core. If the coring is accepted by the Consultant, the Contractor shall make arrangements, through the Consultant, to employ an independent, qualified testing service, at the Contractor's expense.~~

~~The Consultant will specify the location of the coring to ensure that the cores represent the same concrete as the cylinders. The average of three adjacent cores taken from one bridge unit shall constitute a test. The cores shall be taken and tested in accordance with CSA Standard A23.2-14C within seven days of the date of testing the 28-day cylinders. CSA Standard A23.1-09, Clause 4.4.6.6.2 "Cores drilled from a structure" shall not apply. The average strength of each set of three cores shall be equal to or greater than the 28-day specified strength. The core test will represent all bridge units represented by the strength test. Alternatively, the Contractor may choose to take a core test from each of the other units in question, in which case each of these core tests will then represent a bridge unit.~~

~~Where the concrete strength as indicated by the cores is higher than the strength based on the 28-day concrete cylinder tests, the core results shall be used as the basis for acceptance and payment of the concrete. If the core strengths are lower than the strength of the 28-day concrete strength cylinder tests, the cylinder tests shall govern.~~

## ~~7.3~~ 7.3 Erection of Precast Concrete Girders Girder Erection

### ~~7.3.1~~ 7.3.1 General

The Contractor shall erect the precast concrete girders, ~~remove any temporary construction, and do all work required to complete the erection in accordance with the~~ as shown on the Drawings and these specifications. ~~Drilling, coring or the~~ Erection of precast concrete girders shall also include, but is not limited to the following:

- Erection and removal of temporary supporting structures;
- Removal of anchor rod grout can void forms;
- Placing and grouting of connector bolts and diaphragms;

- Post-tensioning installation of any fasteners or anchoring systems or any other modifications shall not be made to the concrete elements, and grouting; and
- Cutting of lifting hooks, and repair of lifting holes and pockets.

The Contractor shall not erect the precast concrete girders until the substructure concrete has been cured a minimum of three days and achieved 80% of the 28 day specified concrete strength ~~requirements~~requirement.

~~Without restricting generality, Cranes shall be used for the handling and erection includes:~~

- ~~— removing anchor bolt grout can lid~~
- ~~— erecting the of precast concrete girders.~~
- ~~— placing and grouting of connector bolts and diaphragms~~
- ~~— post-tensioning~~
- ~~— cutting off lifting hooks, and grouting lifting holes on exterior girders and all lifting hook pockets~~

~~7.3.2 Handling and Storing Materials~~The Contractor shall maintain girder stability; location; and horizontal, vertical and longitudinal alignment at all times during construction.

Lifting forces shall be vertical. Precast concrete girders shall be erected using lifting devices that have been reviewed and accepted by the Consultant and at the designated locations only. Drilling or coring of additional holes or any other modifications will not be permitted.

Grout pads shall be constructed in accordance with Section 8, Bearings.

### 7.3.2 Transportation, Handling and Storing Materials

Girders with webs shall be transported with girder webs in the vertical position. If the Contractor proposes to transport the girders with webs in a position other than vertical, the Contractor shall employ a Professional Engineer registered in the Province of Alberta to prepare and submit a girder transportation assessment to the Consultant for review and acceptance a minimum of two week prior to shipping from the fabrication facility. Review comments provided by the Consultant and/or the Department shall be incorporated into the transportation assessment and resubmitted to the Consultant for review and acceptance prior to shipping from the fabrication facility. The Consultant's review and acceptance shall not be considered as relieving the Contractor of the responsibility for completing the Work in a manner that does not, in the opinion of the Consultant and Department, damage the girders.

Upon arrival at the site and prior to erection, the Contractor in the presence of the Consultant, shall inspect all components to ensure there is no damage and that specification requirements have been met. The Contractor shall provide an adequate flat storage area and space between elements for the inspection. A detailed inspection report shall be provided to the Consultant for review and acceptance within three days of the inspection. Erection work shall not commence until the detailed inspection report has been reviewed and accepted by the Consultant.

Precast concrete girders shall be protected from dirt, road salts, slush or other contaminants during transportation, handling and storage.

Any precast concrete girder damaged during transportation, handling, storing or erection shall be immediately reported to the Consultant and the Department. The Contractor shall provide an engineering assessment report and repair procedure prepared by a Professional Engineer registered in the Province of Alberta experienced in evaluation and inspection of damaged concrete members. The assessment report and repair procedure shall be submitted to the Consultant and the Department for review and acceptance. The Consultant will also arrange to have an independent inspection and assessment performed on the damaged member by a Precast/Prestressed Concrete Institute (PCI) level 2 certified inspector. The Contractor shall provide at least three days' notice for the inspection and facilitate all the activities associated with the inspection. All costs associated with the independent inspection will be the responsibility of the Contractor.

Precast concrete units that become contaminated with any dirt, road salts, slush or other contaminants, shall be cleaned and surface finishes re-instated to the satisfaction of the Consultant prior to erection or installation.

Material to be stored shall be placed upright and shored on timber blocking and. It shall be kept clean and, free from dirt, grease, and any other foreign matter and stored in a properly drained area. Handling and lifting devices shall not mark, damage, or distort members. Precast concrete girders shall be shored and stored in the vertical position.

### 7.3.3 ~~7.3.3~~ Temporary Supporting Structures and Berms

The temporary supporting structures and berms shall be ~~properly designed and substantially,~~ constructed and maintained ~~for the forces which may come upon them.~~ to safely support all loads.

Berms shall be constructed in a manner and of such materials that they will not be eroded by stream flow nor introduce silt into the ~~water.~~ ~~The Contractor shall prepare and submit to the Consultant, for review drawings for temporary supporting structures and berms, and for traffic control and accommodation where applicable. Review of the Contractor's drawings shall not be considered as relieving the Contractor of any responsibility. All drawings submitted shall bear the seal of a Professional Engineer registered in Alberta~~watercourse.

The Contractor shall prepare and submit drawings that clearly indicate details of all temporary supporting structures and/or berms will not be permitted to remain in any stream channel during spring break-up or run-off periods, unless all necessary approvals have been obtained, sealed by a Professional Engineer registered in the Contractor from pertinent agencies.

~~Incidental damage to other property, such as fills and stream banks, resulting from the existence of berms, shall be the responsibility of the Contractor.~~

#### ~~7.3.4 Review of Erection Procedure~~

~~The Contractor shall submit to the Consultant, Alberta, for record purposes the Consultant's review and for examination as to concept only, acceptance a minimum of four copies of a detailed erection procedure three weeks in advance of the scheduled start of erection. Work. The erection procedure shall include all drawings and documents necessary to describe the following:~~

- ~~(a) Access to work, earth berms and work bridges.~~
- ~~(b) Type and capacity of equipment. Cranes shall be used for handling and erecting precast concrete units.~~
- ~~(c) Sequence of operation, including position of cranes, trucks with girders, and traffic accommodation.~~
- ~~(d) Detailed crane position on the ground, particularly adjacent to substructure elements, such as abutment backwalls, with details of load distribution on wheels and outriggers.~~  
  
~~Details of crane position on the structure, showing wheel loads and axle spacing of equipment moving on structure.~~
- ~~(e) Loads and their position from crane wheels and outriggers during all positions of lifting when crane is on structure.~~
- ~~(f) Details of temporary works, supporting structures drawings, including proposed methods to be used to ensure the required splice elevations and structure shape prior to placing concrete, and/or post-tensioning and method of providing temporary supports for stability.~~
- ~~(g) Details of lifting of units, showing vertical forces at lifting hooks.~~
- ~~(h) Provisions for control and adjustment of errors for width and positioning of curbs or exterior units.~~
- ~~(i) Complete details of blocking for bearings where necessary to constrain movements due to horizontal forces and/or gravity effects.~~
- ~~(j) Details of post-tensioning procedures, including strand specifications, jack dimensions, pressures, forces and elongations, and grouting.~~
- ~~(k) Details of release of temporary supporting structures.~~
- ~~(l) Provide an "As Constructed" detailed survey of the substructure showing the following:~~

- ~~— location and elevation of all bearing grout pad recesses,~~
- ~~— shim height at each bearing location,~~
- ~~— top of girder elevations at each bearing (and each splice location where appropriate).~~

~~The erection procedure shall bear the Seal of a Professional Engineer registered in Alberta, who shall assume full responsibility to ensure that his design is being followed. Safety and compliance with the Occupational Health and Safety Act and Regulations thereunder, shall be integral parts of his design.~~

~~The Contractor shall continue to be fully responsible for the results obtained by the use of these sealed drawings, with the Professional Engineer also assuming responsibility, as the Contractor's~~Contractor's Agent, for the results obtained.

~~Work shall not commence until the Consultant has reviewed the proposal. The Contractor's project manager and field superintendent may be required to attend a prejob meeting at a location determined by the Consultant prior to commencement of any field work.~~

~~Before erection begins the Contractor shall do a complete superstructure layout by means of chalk lines and markings applied to all substructure units, showing bearing and girder positions in accordance with the accepted layout plan.~~

~~The Consultant's review~~The Consultant's review and acceptance shall not be considered as relieving the Contractor of the responsibility for the safety of his methods or equipment, nor from carrying out the work in full accordance with the ~~drawings and specifications~~Contract requirements.

7.3.5—Repair to any damage to property, such as earth fills and stream banks, resulting from the existence of berms, and all associated costs shall be the sole responsibility of the Contractor.

#### 7.3.4 Girder Erection Procedure

The Contractor shall submit a detailed girder erection procedure to the Consultant for review and acceptance a minimum of 4 weeks in advance of erection. The erection procedure shall include drawings and supporting documents necessary to describe the following:

- Traffic Accommodation Strategy (TAS);
- Access to the Work, including temporary access berms and/or work bridges;
- Details of temporary works and supporting structures, including:
  - Location, elevation, and grade of support bearings;
  - Theoretical top of girder elevations at bearing and splice locations; and
  - Vertical, horizontal, and longitudinal position adjustment mechanisms;

- An as constructed survey of substructure elements, including:
  - Location and elevation of all bearing grout pad recesses including anchor rod voids;
  - Shim height required at each bearing location; and
  - Longitudinal and transverse measurements between centreline of bearings of all substructure elements.
- Superstructure layout plan, including installation details of reference lines and markings of substructure and bearing components used to determine final bearing and girder positions, and theoretical top of girder elevations at substructure bearing locations;
- Type and capacity of cranes;
- Sequence of operation, including position of cranes and delivery trucks;
- Position of cranes relative to substructure elements such as abutment backwalls, with details of load distribution of wheels and outriggers;
- Lifting devices and lifting points showing lifting forces;
- Girder stabilization details, methods of maintaining girder location and alignment, and details of blocking for girder and bearings;
- Diaphragm and bracing installation schedule and sequence;
- Bolt tightening schedule and sequence as applicable;
- Post-tensioning procedures, including prestressing strand specifications, jack dimensions, pressures, forces and elongations, and grouting;
- Grout pad construction; and
- Temporary supporting structures release and removal.

Installation of bearings shall be in accordance with Subsection 8.4, Installation.

Girder layout and member identification contained in the erection procedure shall be consistent with the girder layout and member identification shown on the Drawings.

The girder erection procedure shall be signed and sealed by a Professional Engineer registered in the Province of Alberta. Safety and compliance with the Occupational Health and Safety Act and Regulations thereunder, shall be an integral part of the procedure.

The Contractor shall not commence any erection work until review of the girder erection procedure by the Consultant has been completed and all comments arising from that review have been addressed to the satisfaction of the Consultant. The Contractor's project manager, field superintendent, and representatives directly involved in the supervision of the work, shall attend a construction milestone meeting prior to commencement of the Work.

The Consultant's review and acceptance shall not be considered as relieving the Contractor of the responsibility for the safety of his methods or equipment, nor from carrying out the Work in full accordance with the girder erection procedure, drawings and specifications.

The Contractor shall follow the girder erection procedure at all times.

### 7.3.5 Fall Protection for Girder Erection and Deck Forming

In order to provide a safe working area for girder erection and deck formwork, the Contractor shall provide 100% fall protection and a safe work procedure. The design of the fall protection and the safe work procedure shall be performed and certified by an individual who is competent in this specialized work. The Contractor shall provide this information to the Consultant a minimum of 2 weeks prior to commencement of the Work.

### 7.3.47.3.6 Girder Adjustments

It is essential that the girders be erected with utmost attention being given Adjustment to girder positioning, alignment, and elevation. The Contractor shall adjust girder position, bearing location and bearing elevation in order shall be completed to achieve as closely as possible the lines and grades shown on the Drawings. or those reviewed and accepted by the Consultant.

The Contractor shall maintain the precast concrete units in correct alignment at all times during construction.

The Contractor shall minimize ~~any~~ differential camber (girder to girder), and the sweep of the girders by jacking, loading of girders, or winching, or whatever means are necessary, and in a manner acceptable to the Consultant. Once girder position has been reviewed and accepted by the Consultant, the Contractor shall provide the necessary temporary attachments to ~~hold the girders in~~ maintain girder position.

The maximum dimensional deviation in mm, of erected precast concrete ~~units~~ girders from that as detailed on the drawings shall not exceed the following:

- Sweep (NU Girders) ~~—————~~; 1 mm/m;
- Sweep (Other Precast Concrete Units) ~~—————~~;  deviation from true, 20 mm x length (m) ) $\pm$  50

~~7.3.5~~7.3.7 ~~7.3.6~~—Lifting Hooks and Lifting Holes

After the Consultant has ~~approved~~reviewed and accepted the erected girder locations and positions of the girders, ~~all~~ lifting holes on exterior girders shall be filled with an appropriate Alberta Transportation's approved patching material. All lifting hooks shall be cut off 50 mm below the concrete surface, ~~and~~ All lifting ~~hookholes and~~ pockets shall be filled with an accepted grouta concrete patching product listed on Alberta Transportation's Product List in the applicable category in accordance with the manufacturer's recommendations specified on the published product data sheet.

~~7.3.6~~7.3.8 ~~7.3.7~~—Post-Tensioning System~~7.3.6.1~~7.3.8.1 ~~7.3.7.1~~ General

This Work consists of post-tensioning and grouting of cable ducts for cast-in-place and precast concrete components.

~~7.3.6.2~~7.3.8.2 ~~7.3.7.2~~ Standards

~~Applicable requirements of the current edition of~~ The following standards shall be followed:

- ~~CSA A23.1/23.2 - Concrete Materials and Method of Concrete Construction;~~
- ~~CSA A23.4 - Precast Concrete Materials and Construction;~~
- ~~Section 4 of the Specifications for Bridge Construction, Cast-In-Place Concrete;~~
- ~~Guide Specification Acceptance Standards for Post Tensioning Systems~~ Post-Tensioning Institute (PTI);
- ~~Specifications for Grouting of Post Tensioned-Structures~~ PTI; and
- ~~AASHTO LRFD Bridge Construction Specifications.~~

7.3.7.3 In the case of conflicting requirements the most stringent requirement shall govern.

~~7.3.6.3~~7.3.8.3 Qualification

The ~~Contractor or the Sub-Contractor~~ shall have extensive experience in this Work and shall utilize only fully trained, competent and experienced ~~operators~~personnel. The Contractor shall ensure the site supervisor responsible for the post tensioning and grouting operations is at the site whenever these operations are being ~~carried out~~completed.

- 7.3.7.4 The site supervisor of post tensioning and grouting operations shall be certified to PTI Level 2 Bonded PT Field Specialist;
- The foreman for each installation and stressing crew shall be certified to PTI Level 2 Bonded PT Field Specialist;
- The foreman for each grouting crew shall be certified to PTI Level 2 Bonded PT Field Specialist; and
- At least 25% of the members of each crew shall be certified in PTI Level 1 Bonded – Field Installation.



## 7.3.6.47.3.8.4 Submittals

The Contractor shall submit post tensioning design notes, independent check notes and shop drawings in accordance with Subsection 7.2.3.2, Design Notes and Independent Check Notes, and this Subsection. As a minimum, the following information for the Consultant's review at least four weeks prior to commencement of post-tensioning work shall be included on shop drawings:

- ~~Five sets of post tensioning drawings illustrating the~~ Stressing system and where appropriate, design details and sequence of stressing; and
- ~~Five sets of~~ Stressing calculations taking into account all applicable losses.

~~Information for mill~~ Mill test reports and ~~stress-strain/load/elongation~~ stress-strain/load/elongation curves for the ~~stressing~~ prestressing strand shall be provided ~~at least a minimum of~~ at least a minimum of 5 days prior to ~~the commencement of~~ the commencement of stressing.

7.3.6.57.3.8.5 ~~7.3.7.5~~ Materials7.3.6.5.17.3.8.5.1 ~~(a)~~ Stressing ~~Prestressing~~ Strand

Stressing ~~Prestressing~~ strand shall conform to the requirements of ~~sections 7.2.4.9 and 7.2.5.3-Subsection 7.2.4.9, Prestressing Strand and Subsection 7.2.5.3, Prestressing Strand.~~

Corrosion inhibitor ~~is~~ will be required when the stressing and grouting operations are not completed within 20 calendar days of the installation of the ~~stressing steel~~ prestressing strand. The corrosion inhibitor, when required, shall be water-soluble and ~~shall~~ have no deleterious effect on the ~~steel~~ prestressing strand, grout ~~or~~, concrete, or bond strength of the ~~steel~~ prestressing strand to concrete.

7.3.6.5.27.3.8.5.2 ~~(b)~~ Anchorage and Distribution

All ~~stressing steel~~ prestressing strand shall be secured at the ends by means of permanent anchoring devices reviewed and accepted by the Consultant. These devices shall comply with ~~CSA S6-06~~ Clause 8.4.4.1.

Steel distribution plates or assemblies may be omitted when the anchoring devices are sufficiently large and used in conjunction with an embedded steel grillage that effectively distributes the compressive stresses to the concrete.

7.3.6.5.37.3.8.5.3 ~~(c)~~ Ducts

Post-Tensioning duct material shall be in accordance with Subsection 7.2.4.13, Voids, Ducts, and Conduit.

The Contractor shall provide mortar tight inlets and outlets in all ducts with a nominal diameter of 20 mm in the following locations:

- The anchorage area;
- All high points of the duct, when the vertical distance between the highest and lowest point is more than 0.5 m;
- Place an inlet at or near the lowest point; and
- Place free draining outlet at all low points of duct.

The Contractor shall provide inlets and outlets with valves, caps or other devices capable of withstanding the grouting pressure. The ducts and vents shall be securely fastened in place to prevent movement. The Contractor shall provide details of inlets and outlets on the shop drawings.

#### ~~7.3.6.5.4~~ 7.3.8.5.4 (d) — Concrete

Concrete shall be supplied in accordance with ~~section 7.2.4, however~~ Subsection 7.2.4, Materials and meet the ~~maximum size of coarse aggregate shall be 10 mm and 28 day minimum following requirements:~~

- The minimum 28 day concrete compressive strength ~~of shall be~~ 50 MPa unless otherwise specified; and
- ~~(e) —~~ The maximum nominal size of the coarse aggregate shall be in accordance with Subsection, 4.3.2.2, of CSA A23.1, Nominal Maximum Size of Aggregate.

#### ~~7.3.6.5.5~~ 7.3.8.5.5 Grout

Grout shall be a Class C as grout meeting the requirements described in Table 10.9.3-1 and the properties ~~as described listed~~ in Table 10.9.3-2 of the AASHTO LRFD Bridge Construction Specification. ~~In addition to the requirements noted in the tables, a test for~~ The wet density shall also be ~~performed provided by the manufacturer~~ in accordance with ~~the "ASTM C138, Standard Test Method for Density" ASTM C138.~~

The average minimum compressive strength of 3 cubes at 28 days shall be 50 MPa and measured in accordance with CSA A23.2-1B.

Pre-bagged grouts shall be packaged in plastic lined bags or coated containers, stamped with the date of manufacture, lot number and mixing instructions. Copies of the quality control data for each lot number and shipment sent to the job site shall be provided to the Consultant for review. prior to grouting. Materials with a total time from manufacture to usage in excess of six months shall be retested and certified by the supplier before use, or shall be removed from the job site and replaced.

~~The average minimum compressive strength of 3 cubes at 28 days shall be 50 MPa as per CSA A23.2-1B. The results for bleed test and fluidity test shall meet the requirements noted in Table 10.9.3-2 of the AASHTO LRFD Bridge Construction Specifications.~~

~~The Contractor is responsible to perform all grout testing in the field at his cost and he shall ensure that the testing is witnessed by the Consultant. The testing shall be completed by a qualified and experienced technician. The frequency of grout strength testing shall be as follows:~~

Strength Test

~~Precast Concrete Girders: — One strength test per girder line~~

~~Cast-In-Place Girders: — One strength test for every four longitudinal ducts~~

~~The strength test shall be done by an independent CSA-certified testing lab.~~

~~7.3.6.5.5.17.1.1.1.1.1.1~~ Blood Test

~~At the beginning of each day's grouting operation, perform a wick-induced bleed test in accordance with ASTM C940 and with modifications noted in Table 10.9.3-2 of the AASHTO LRFD Bridge Construction Specifications.~~

Fluidity Test

~~At the inlet and outlet, perform fluidity test in accordance with the standard ASTM C939 flow cone test or the modified ASTM C939 test.~~

Wet Density Test

~~Perform wet density test in accordance with American Petroleum Institute (API) Mud Balance Test API Practice 13B-1: "Standard Procedures for Field Testing Water-based Drilling Fluids".~~

~~7.3.6.6~~ 7.3.8.6 ~~7.3.7.6~~ Equipment

~~7.3.6.6.17.3.8.6.1~~ (a) — Stressing

Hydraulic jacks and pumps of sufficient capacity shall be used for tensioning of prestressing strands.

The force induced in the ~~stressing~~prestressing strand shall be measured using calibrated jacking gauges, load cells or a calibrated dynamometer.

The pressure gauge shall have an accurate reading dial at least 150 mm in diameter.

The forces to be measured shall be within 25% and ~~75-percent%~~ of the total graduated capacity of the gauge, unless calibration data clearly establishes consistent accuracy over a wider range.

The measuring devices shall be calibrated at least once every six months. The jack and the gauge shall be calibrated ~~as a unit~~together. A certified calibration chart shall be kept with each gauge.

~~7.3.6.6.2~~ ~~7.3.8.6.2~~ (b) — Grouting

A high speed shear mixer shall be used that is capable of continuous mechanical mixing and producing grout that is free of lumps and undispersed cement. The water supply to the mixer shall be measured by an accurate gauge.

The holding tank shall be capable of keeping the mixed grout in continuous motion until it is used. The outlet to the pump shall have a screen with 3 mm maximum clear opening.

A positive displacement type pump shall be used which is capable of producing an outlet pressure of at least 1.0 MPa. A pressure gauge having a full-scale reading of no greater than 2 MPa shall be placed at some point in the grout line between the pump outlet and the duct inlet. ~~A spare fully functional pump shall also be on site.~~

The Contractor shall have an additional backup pump shall be on site ready for use at all times during grouting operations.

Standby flushing equipment with water supply shall be available at the site prior to commencing grouting.

The grouting equipment shall be of sufficient capacity to ensure that grouting of the longest duct can be completed within 30 minutes after mixing.

Grout hoses and their rated pressure capacity shall be compatible with the pump output and the maximum grout pressure. All connections from the grout pump to the duct shall be airtight so that air cannot draw into the duct.

~~7.3.6.7~~ ~~7.3.8.7~~ ~~7.3.7.7~~ Construction~~7.3.6.7.1~~ ~~7.3.8.7.1~~ (a) — Checking Post-Tensioning Ducts

Placement of post-tensioning ducts shall be in accordance with Subsection 7.2.5.4, Void, Duct, Conduit and Reinforcement Placing Tolerances.

Prior to placing ~~post-tensioning steel~~ prestressing strand, the Contractor shall demonstrate to the satisfaction of the Consultant that all ducts are unobstructed.

~~7.3.6.7.2~~ ~~7.3.8.7.2~~ (b) — Welding

Proposed welding of ~~stressing tendons shall not be permitted.~~ ~~Stressing tendons shall not be used as an electrical "ground".~~ ~~Where prestressing strand ends will require the ends of strands are welded together to form a tendon so that the tendon may be pulled through the ducts, the Consultants review and acceptance.~~ The greater of the length of the prestressing strands used ~~as an~~ within the electrical "ground" circuit or 1 m, ~~whichever is greater,~~ shall be cut off from the welded end prior to stressing.

7.3.6.7.37.3.8.7.3 (c) — Post-Tensioning

Post-tensioning shall be carried out as per in accordance with the reviewed drawings and stressing calculations. The stressing and release of tendons shall be done in the sequence specified on the Drawings. All strands in each tendon shall be stressed simultaneously with a multi-strand jack. The force in the tendons shall be measured by means of pressure gauge and shall be verified by means of tendon elongation. All tendons shall be tensioned to a preliminary force as necessary to eliminate any slack in the tensioning system before elongation readings are started. This preliminary force shall be between 15% and 25% of the final jacking force.

Stressing tails of post-tensioned tendons shall not be cut off until the record of gauge pressures and tendon elongations are provided by the Contractor to the Consultant for review and acceptance. A record of the following post-tensioning operations shall be kept for each tendon installed:

- Project Name & File Number<sub>i</sub>;
- Contractor/Subcontractor<sub>i</sub>;
- Tendon location & size<sub>i</sub>;
- Date tendon installed<sub>i</sub>;
- Tendon pack/heat number<sub>i</sub>;
- Modulus of elasticity (E)<sub>i</sub>;
- Date stressed<sub>i</sub>;
- Jack and gauge identifier<sub>i</sub>;
- Required jacking force and gauge pressures<sub>i</sub>;
- Elongation (anticipated and actual)<sub>i</sub>;
- Anchor set (anticipated and actual)<sub>i</sub>;
- Stressing sequence<sub>i</sub>;
- Witnesses to stressing operation<sub>i</sub>;
- Grout information (Brand Name)<sub>i</sub>;
- Time for grouting each tendon; and
- Date grouted<sub>i</sub>.

7.3.6.7.47.3.8.7.4 (d) — Concreting

The anchorage recesses shall be concreted after tensioning but before grouting the tendons.

The concrete surface of the anchorage recesses shall be abrasive blasted. ~~The recesses shall be thoroughly wetted and covered with a thin cement scrub coat immediately before placing fresh concrete.~~ Prior to concrete placement, concrete surfaces shall be blown clean with compressed air and saturated with water meeting the requirements of Subsection 7.2.4.2, Water.

7.3.6.7.57.3.8.7.5 ~~(e)~~ — Grouting

All ducts or openings shall be clean and free of all deleterious matter that would impair bonding of the grout to the ducts and ~~stressing steel prestressing strand~~. All ducts shall be thoroughly ~~flushed out with water and~~ blown out with oil free compressed ~~oil free~~ air. All inlets and outlets shall be checked for their capacity to accept injection of grout by blowing oil free compressed ~~oil free~~ air through the system.

Before stressing and grouting internal or external tendons, the Contractor shall install all grout caps, inlets and outlets and test each duct with oil free compressed air to determine whether duct connections need repair. The Contractor shall pressurize each duct to 345 kPa (50 psi) and lock-off the outside air source and record pressure for one minute. A pressure loss of 170 kPa (25 psi) is acceptable for ducts up to 45 m long, and a pressure loss of 100 kPa (15 psi) is acceptable for ducts longer than 45 m. If the pressure loss exceeds the acceptable limit, the Contractor shall repair the leaking connections using methods acceptable to the Consultant, and then retest.

A thoroughly mixed grout, meeting all the requirements described in ~~7.3.7.5(e)~~ Subsection 7.3.8.5.5, Grout, shall be passed through a screen with 3 mm maximum clear openings before entering the pump. All grout vents shall be opened prior to commencement of grouting. The duct shall be completely filled by injecting grout from the lowest end of the tendon on an uphill direction. Grout shall be pumped continuously through the duct until no visible signs of water or air are ejected at the outlet. A fully operational grout pump shall be on site for all pumping procedures. A continuous, one way flow of grout shall be maintained at a rate of 5 to 15 lineal metres of duct per minute. The grouting of a tendon shall be completed within 30 minutes of mixing unless otherwise accepted by the Consultant.

Normal pumping pressure shall be between 0.1 to 0.4 MPa, measured at the inlet. The pumping pressure at the injection vent shall not exceed 1 MPa. If the actual pressure exceeds the maximum allowed, the injection vent shall be closed and the grout shall be injected at the next vent that has been or is ready to be closed as long as one way flow is maintained. Grout shall not be injected to a succeeding vent from which grout has not yet flowed. For each tendon, immediately after uncontaminated uniform grout discharge begins, a fluidity test shall be performed. The measured grout efflux time shall not be faster than the efflux time measured at the inlet or the minimum efflux time established. If the grout efflux time is not acceptable, additional grout shall be discharge from the discharge outlet. ~~Grout efflux time shall be tested.~~ This cycle shall be continued until acceptable grout fluidity is achieved. In addition to fluidity test, ~~check~~ the grout density shall be tested using the ~~Wet Density Method. Mud Balance Test~~ and the density at the final outlet shall not be less than the grout density at the inlet. ~~To ensure the tendon remains filled with grout, the ejection and injection~~ Vents shall be closed in the designed sequence, ~~respectively~~ under pressure when the tendon duct is completely filled with grout. Valves and caps ~~are~~ shall not to be removed until the grout has set.

Grouting will not be permitted when the air temperature is below 5 °C or above 25 °C, nor when there are other conditions judged by the Consultant to be detrimental to the grouting operations.

The Contractor shall provide 50 mm deep grout tube termination recesses formed around the tubes projecting from top of the deck concrete. After grouting, all tubes shall be cut flush with the bottom of the recesses, and the recesses shall then be grouted flush with the top of the deck concrete.

The Contractor shall complete grout testing in accordance with Subsections 7.3.8.7.5.1, Compressive Strength Test through 7.3.8.7.5.4, Mud Balance Test and ensure that the testing is witnessed by the Consultant. The grout testing shall be completed by ACI or CSA certified testers and review and accepted by the Consultant. Grout testing reports shall be submitted to the Consultant within 3 days of test completion.

#### 7.3.8.7.5.1 Compressive Strength Test

- Precast Concrete Girders: One compressive strength test per girder line
- Cast-In-Place Girders: One compressive strength test for every four longitudinal ducts

The compressive strength test shall be completed by an independent testing laboratory certified to CSA A283 and in accordance with CSA A23.2-1B.

#### 7.3.8.7.5.2 Bleed Test

7.3.7.8 At the beginning of each day's grouting operation, a wick induced bleed test shall be completed in accordance with ASTM C940 and with modifications noted in Table 10.9.3-2 of the AASHTO LRFD Bridge Construction Specifications.

#### 7.3.8.7.5.3 Fluidity Test

At the inlet and outlet of each duct, a fluidity test shall be completed in accordance with the standard ASTM C939 flow cone test or the modified ASTM C939 test.

#### 7.3.8.7.5.4 Mud Balance Test

A mud balance test shall be completed for each batch of grout in accordance with American Petroleum Institute (API) Mud Balance Test API Practice 13B-1: "Standard Procedures for Field Testing Water-based Drilling Fluids".

#### 7.3.6.87.3.8.8 Inspection

The stressing and grouting will require the Consultant's presence. The Contractor shall ensure that adequate notice be given to the Consultant for these operations and access to the Work is provided at all times.

~~7.3.7.3.9~~ **7.3.8** — Removal of Temporary Supporting Structures and Site Clean-up

Upon completion of ~~the girder~~ erection ~~and before final acceptance, including post-tensioning where specified,~~ the Contractor shall remove all earth material or temporary supporting structures ~~placed in the stream channel or elsewhere used~~ during construction. ~~He~~**The Contractor** shall remove all piling, excavated or surplus materials, rubbish and temporary buildings, replace or renew any damaged fences, and restore in an acceptable manner all property damaged during the execution of his work. Disposal of surplus materials shall be in a manner and location satisfactory to the Consultant.

The Contractor shall leave the bridge site, roadway and adjacent property in a ~~neatly restore, and presentable~~ condition, ~~satisfactory~~ acceptable to the Consultant; When required, ~~he~~**the Contractor** shall provide written evidence that affected property owners or regulatory agencies have been satisfied.

**7.4** ~~7.4~~ — Payment7.4.1 Supply

Payment for the supply of precast concrete ~~Girders and Associated Material~~ **units** will be made ~~on the unit price bid per girder. at~~ the unit prices bid ~~shall include for~~ “Precast Concrete Units – Supply” for the type and size specified less any applicable payment adjustments for compressive strength, and will be full compensation for ~~the costs~~ supply and manufacture of furnishing precast concrete units; including all materials, labour, tools, equipment, tools and incidentals necessary for fabrication to complete the Work as shown on the Drawings and to the satisfaction of the Consultant.

Payment for the 90% of the unit price bid will be paid once the precast concrete units have been acceptably supplied and delivered to the bridge site. The remaining 10% of the unit price bid will be paid once the precast concrete units have been acceptably installed.

7.4.2 Delivery of Girders

Payment for the delivery of precast concrete units will be made ~~on the basis of at~~ the lump sum price bid and ~~shall include prices bid for~~ “Precast Concrete Units – Delivery” for the type and size specified, and will be full compensation for ~~the costs to deliver loading; hauling to the project site; unloading; and~~ all precast concrete girders and associated materials to the bridge site ~~including labour, equipment, tools and incidentals necessary to complete the Work as shown on the Drawings and to the satisfaction of the Consultant.~~

All necessary approvals and permits ~~from the Motor Transport Board and/or the appropriate local road authorities.~~, cleaning of girders to remove any foreign material materials will be considered incidental to the Work and no ~~separate separator or additional~~ payment will be made.

90% of the lump sum price bid will be paid once the precast concrete units have been acceptably supplied and delivered to the bridge site. The remaining 10% of the lump sum price bid will be paid once the precast concrete units have been acceptably installed.



7.4.3 Erection

Payment for the erection of ~~Girders~~precast concrete units will be made ~~on the basis of a~~ the lump sum ~~price~~prices bid ~~for~~ “Precast Concrete Units - Erection” for the type and ~~shall include~~size specified, and will be full compensation for ~~the cost of furnishing all materials, labour, tools, equipment, tools and incidentals necessary to acceptably erect the precast concrete girders and associated material and complete site clean-up~~the Work as shown on the Drawings and to the satisfaction of the Consultant.

7.4.4 Post-tensioning and Grouting

Payment for post-tensioning and grouting will be made ~~on the basis of a~~ the lump sum ~~price bid~~price ~~which shall include~~bid for “Post-Tensioning and Grouting”, and ~~will be~~ full compensation for ~~supply and installation of post tensioning systems; the cost of furnishing~~supply and placement of grout; and all labour, materials, labour, tools, equipment, tools and incidentals necessary to acceptably complete the post-tensioning and grouting process and clean-upWork as shown on the Drawings and to the satisfaction of the Consultant.

~~When materials are delivered to the work site, payments for~~ All costs associated with grouting in cold weather, when required, will be considered incidental to the Work, and no separate or additional payment will be made. ~~Supply of Precast Concrete Girders and Associated Material, and Delivery of Girders~~ will be made to a maximum of 90% of the bid price of the materials and delivery. ~~Payment for the remainder of the prices bid for supply and delivery will be made as the materials are acceptably installed.~~



STANDARD SPECIFICATIONS FOR BRIDGE CONSTRUCTION

**SECTION 8 BRIDGE BEARINGS**

TABLE OF CONTENTS

<b>8.1</b>	<b>General</b>	<b>8-1</b>
<b>8.2</b>	<b>Design Requirements</b>	<b>8-1</b>
8.2.1	Elastomeric Bearings	8-2
8.2.1.1	Sliding Surfaces	8-2
8.2.1.2	PTFE Element	8-2
8.2.1.3	Self-Rocking Pintle	8-2
8.2.2	Pot Bearings	8-2
8.2.2.1	Loadings, Translations and Rotations	8-2
8.2.2.2	Sliding Surfaces	8-3
8.2.2.3	Fasteners, Anchorages, and Guides for Lateral Restraint	8-4
<b>8.3</b>	<b>Supply and Fabrication</b>	<b>8-5</b>
8.3.1	Standards	8-5
8.3.2	Qualification	8-6
8.3.3	Engineering Data	8-6
8.3.3.1	Welding Procedures	8-6
8.3.3.2	Design Notes, Independent Check Notes, and Shop Drawing Submission Requirements	8-6
8.3.3.3	Mill Test Reports	8-8
8.3.4	Materials	8-8
8.3.4.1	Steel	8-8
8.3.4.2	Stainless Steel	8-8
8.3.4.3	Brass	8-8
8.3.4.4	Elastomer	8-9
8.3.4.5	PTFE	8-9
8.3.4.6	Lubricant	8-9
8.3.4.7	Adhesives	8-9
8.3.4.8	Anchor Rods and Connecting Bolts	8-9
8.3.5	Welding	8-10
8.3.5.1	Filler Metals & Welding Processes	8-10
8.3.5.1.1	Submerged Arc Welding (SAW)	8-11
8.3.5.1.2	Shielded Metal Arc Welding (SMAW)	8-11
8.3.5.1.3	Metal Core Arc Welding (MCAW)	8-11
8.3.5.2	Cleaning Prior to Welding	8-11
8.3.5.3	Tack and Temporary Welds	8-11
8.3.5.4	Run-off Tabs	8-11
8.3.5.5	Preheat and Interpass Temperatures	8-12
8.3.5.6	Grinding of Welds	8-12
8.3.5.7	Submission of Repair Procedures	8-12
8.3.5.8	Arc Strikes	8-12
8.3.5.9	Plug and Slot Welds	8-12
8.3.6	Fabrication	8-12
8.3.6.1	Plain Elastomeric Bearings	8-13

8.3.6.2	Laminated Elastomeric Bearings .....	8-13
8.3.6.3	Pot Bearings .....	8-13
8.3.6.4	Fixed Steel Plate Rocker Bearings .....	8-13
8.3.6.5	Machining .....	8-14
8.3.6.6	Identification .....	8-14
8.3.6.7	Galvanizing.....	8-14
8.3.6.8	Base Plate Corrosion Protection .....	8-15
8.3.6.9	Tolerances.....	8-16
8.3.7	Testing and Inspection .....	8-17
8.3.7.1	Access .....	8-17
8.3.7.2	Responsibility .....	8-17
8.3.7.3	Testing by the Contractor.....	8-18
	8.3.7.3.1 Elastomeric Bearings .....	8-18
	8.3.7.3.2 Pot Bearings.....	8-19
8.3.7.4	Testing by the Consultant .....	8-19
8.3.7.5	Notification to Ship.....	8-19
8.3.7.6	Fabrication Outside of Canada .....	8-19
8.3.8	Approved Pot Bearing Fabricators .....	8-20
<b>8.4</b>	<b>Installation .....</b>	<b>8-20</b>
8.4.1	General .....	8-20
8.4.2	Bearing and Anchorage .....	8-21
8.4.3	Grouting of Anchor Rod Voids and Bearing Grout Pads.....	8-22
	8.4.3.1 Grouting in Cold Weather .....	8-23
<b>8.5</b>	<b>Warranty.....</b>	<b>8-23</b>
<b>8.6</b>	<b>Payment .....</b>	<b>8-23</b>
8.6.1	Supply and Delivery .....	8-23
8.6.2	Installation.....	8-23

## **8.1 General**

This specification is for the supply, fabrication, delivery and installation of plain and ~~steel reinforced laminated~~ elastomeric bearings, pot bearings and fixed steel plate rocker bearings. The ~~steel reinforced laminated~~ elastomeric bearing and pot bearing components between sole plates and base plates shall be designed by the bearing supplier in accordance with the requirements of ~~contract~~the Drawings and these specifications. Design details of elastomeric bearings shall also be in accordance with Typical Detail Drawing ~~S-4764~~T-1761, Typical Expansion Bearing Details.

### **8.1.2 8.2 Design Requirements**

#### **8.2.1 Elastomeric Bearings**

##### **8.2.1.1 General**

The design of ~~the elastomeric~~ bearings shall be ~~carried out~~completed by the bearing supplier. ~~The bearing supplier's design engineer shall be a Professional Engineer registered in the Province of Alberta. Shop drawings shall be stamped, signed and sealed by the bearing supplier's design engineer.~~

~~The elastomeric~~ Bearings shall be designed to accommodate the loadings, translations and rotations specified on the ~~contract~~ Drawings, in accordance with the requirements of ~~CAN/CSA - S6~~, and the exceptions noted in this specification.

Sole plates and base plates shall be supplied by the bearing supplier, and shall conform to the details shown on the ~~contract~~ Drawings. Any proposed adjustments of these details shall be ~~reviewed and accepted by~~submitted to the Consultant for review and acceptance prior to fabrication.

The entire bearing assembly, between the sole plate and base plate shall be replaceable without damage to the structure and without removal of any concrete, welds or anchorages permanently attached to the structure and without lifting the superstructure more than 5 mm. Bearings shall not be recessed into plates that are permanently attached to the structure.

Bearings shall be designed to prevent moisture and dirt from entering the internal surfaces. The bearings shall be fabricated from materials that are durable and are protected ~~8.2.1.2~~ from corrosion so as to perform the intended function.

### 8.2.1 Elastomeric Bearings

#### ~~8.1.1.18.2.1.1~~ 8.2.1.1 Sliding Surfaces

Sliding surfaces shall allow translation by sliding of a stainless steel surface against a flat mating polytetrafluoroethylene (PTFE) ~~elements~~sheet. The flat PTFE sheet shall be recessed and bonded into a 2.5 mm deep recess in the top of a 10 mm thick galvanized steel plate. The galvanized plate shall be vulcanized to the top of the elastomeric pad. The galvanized steel plate shall have the same plan dimensions as the elastomeric pad and act as the top laminate in the elastomeric bearing.

#### ~~8.1.1.28.2.1.2~~ 8.2.1.3 PTFE Element

The PTFE element shall be a 5.0 mm thick unfilled, and unlubricated flat PTFE sheet.

#### ~~8.1.1.38.2.1.3~~ 8.2.1.4 Self-Rocking Pintle

A single self-rocking pintle welded under the base plate shall be used to ensure uniform contact between the elastomeric bearing pad and the girder bottom flange ~~at erection~~. Where double pintles are shown on the ~~contract~~ Drawings, the pintles shall be centred beneath the bearing along a line perpendicular to the longitudinal axis of the girder. The pintle or pintles shall be supported on galvanized steel shim stacks of the appropriate thickness to achieve the correct bearing elevation.

#### ~~8.2.1.5~~ Replaceability

~~The entire bearing assembly, between the sole plate and the base plate shall be replaceable without damage to the structure and without removal of any concrete, welds or anchorages permanently attached to the structure and without lifting the superstructure more than 5 mm. Bearings shall not be recessed into plates that are permanently attached to the structure.~~

#### ~~8.1.28.2.2~~ 8.2.2 Pot Bearings

##### ~~8.2.2.1~~ General

~~The design of pot bearings shall be carried out by the bearing supplier. The bearing supplier's design engineer shall be a Professional Engineer registered in the Province of Alberta. Shop drawings shall be stamped, signed and sealed by the bearing supplier's design engineer.~~

~~The pot bearing shall be designed for the loadings, translations and rotations specified on the contract drawings, in accordance with the requirements of CAN/CSA-S6 and the exceptions noted in this specification.~~

##### 8.2.2.1 Loadings, Translations and Rotations

The average stress in the elastomer at serviceability limit state loads shall not exceed 30 MPa.

~~Sole plates and base plates shall be supplied by the bearing supplier, and shall conform to the details shown on the contract drawings. Any adjustments of these details shall be reviewed and accepted by the Consultant prior to fabrication.~~

#### ~~8.2.2.2~~ **Translations and Rotations**

Provision for translation shall be through sliding of a stainless steel surface against a mating PTFE element. The translational capacity in an unrestrained direction shall be as specified on the ~~contract drawings~~ Drawings.

Provision for rotation about any horizontal axis shall be by means of a single disc of confined elastomer. Brass rings shall not be considered in determining the effective thickness of the elastomeric disc. The effective thickness of the elastomeric disc to evaluate the rotational capacity shall be limited to the thickness of the disc excluding the brass rings.

The rotational capacity about any horizontal axis shall be as specified on the ~~contract~~ Drawings. The rotational capacity about the vertical axis through the centre of the bearing shall be as specified or  $\pm 1^\circ$ , whichever is greater.

Rotational bearings shall be capable of resisting the specified lateral loads in any direction in combination with the applicable vertical loads.

Brass sealing rings shall be flat and smooth on all surfaces and conform to the requirements of ~~CAN/CSA -S6~~.

The depth of the pot wall shall be such that a minimum vertical distance of 2.5 mm remains between top of the pot wall and the closest point of contact of the brass sealing rings with the pot wall upon rotating the piston an amount equal to the specified rotation at ULS.

The pot and piston surfaces in contact with the confined elastomer shall be lubricated with silicone grease. The bearing shall be sealed by a one-piece continuous preformed closed-cell compressible ring against entry of dirt, dust, and moisture between the elastomer and the pot and piston contact surfaces. Any joint in the ring shall be bonded and the strength shall be at least equal to the strength of the ring.

#### ~~8.1.2.18.2.2.2~~ **8.2.2.3 Sliding Surfaces**

Sliding surfaces shall allow translation by sliding of a metal surface against a mating PTFE element. For planeplain surfaces, the metal surface shall be stainless steel. The metal surface shall overlap the PTFE by at least 25 mm at extremes of movement on each side and, except for guides for lateral restraint, shall be positioned above the PTFE element.

Except when used as mating surfaces for guides for lateral restraint, the PTFE resin shall be virgin material and shall be used as unfilled sheets and shall contain spherical reservoirs for lubricant pressed into its surface. The diameter of the reservoirs shall not exceed 8 mm measured at the surface of the PTFE, and the depth shall not be less than 2 mm nor more than half the thickness of the PTFE. The reservoirs shall be evenly distributed across the surface of the PTFE and shall occupy 20% to 30% of the surface. PTFE used as mating surface for guides for lateral restraint shall not be dimpled or lubricated. All PTFE elements shall be fully bonded and recessed in a rigid backing material.

All PTFE surfaces except those that act as mating surfaces for guides for lateral restraint or that are subjected to a contact pressure of less than 5 MPa shall be permanently lubricated with silicone grease.

The average contact pressure for unfilled PTFE elements based on the gross area of the PTFE shall not exceed the values given in Table 8-1, [Average Contact Pressure for unfilled PTFE Elements](#).

**Table 8-1: Average Contact Pressure for unfilled PTFE Elements**

Limit State	Permanent Load, MPa	Total Load, MPa
Serviceability	25	35
Ultimate	40	55

The maximum contact pressures at the extreme edges of flat and curved PTFE elements shall not exceed 1.2 times the values indicated above.

The average contact pressure at serviceability limit state loads for PTFE elements filled with up to 15% mass of glass fibers used to face mating surfaces of guides for lateral restraints shall not exceed 45 MPa.

The coefficient of friction between stainless steel sliding surfaces and lubricated virgin PTFE shall be as per clause 14.7.2.5 and Table 14.7.2.5-1 of the 2012 AASHTO LRFD Bridge Design Specifications.

#### [8.1.2.28.2.2.3](#) [8.2.2.4](#) Fasteners, Anchorages, and Guides for Lateral Restraint

Fasteners, anchorages and translational elements with lateral restraints shall be capable of resisting either of the following lateral loads:

- For bearings with a capacity of 5,000 kN or less at serviceability limit state, 10% of the vertical load capacity.
- For bearings with a capacity over 5,000 kN at serviceability limit state, 500 kN plus 5% of the vertical load in excess of 5,000 kN.



Guides for lateral restraint shall be arranged to permit the required rotations about both the horizontal and vertical axis. The translational elements of guides for lateral restraint shall be faced with stainless steel and shall provide lateral restraint by sliding against mating surfaces faced with PTFE.

The beneficial effect of friction shall be neglected in proportioning fasteners and anchors, except for slip resistant connections which shall be designed to the requirements of ~~CAN/CSA S6-06~~ Clause 10.18.2.

#### ~~8.2.2.5~~ ~~Replaceability~~

~~The entire bearing assembly, between the sole plate and the base plate shall be replaceable without damage to the structure and without removal of any concrete, welds or anchorages permanently attached to the structure and without lifting the superstructure more than 5 mm. Bearings shall not be recessed into plates that are permanently attached to the structure.~~

#### ~~8.2.2.6~~ ~~Durability~~

~~Bearings shall be designed to prevent moisture and dirt from entering the internal surfaces. The bearings shall be fabricated from materials that are durable and are protected against corrosion so as to perform the intended function.~~

### ~~8.2.3~~ ~~Fixed Rocker Steel Bearings~~

#### ~~8.2.3.1~~ ~~General~~

~~Fixed rocker steel bearings shall conform to the details shown on the contract drawings. Any adjustments to these details shall be reviewed and accepted by the Consultant prior to fabrication.~~

### ~~8.2.3~~ ~~8.3~~ ~~Supply and Fabrication~~

#### ~~8.2.18.3.1~~ ~~8.3.1~~ ~~Standards~~

Fabrication of plain and laminated elastomeric bearings, pot bearings and fixed steel plate rocker ~~steel~~ bearings shall conform to:

- The American Association of State Highway and Transport Officials (AASHTO) LRFD Bridge Construction Specifications;<sub>1</sub>
- AASHTO's Standard Specifications for Transportation Materials and Methods of Sampling and Testing M251-06 Standard Specification for Plain and Laminated Elastomeric Bridge Bearings;<sub>1</sub> and
- The American Welding Society (AWS) - Bridge Welding Code D1.5.

~~Where imperial/metric conversions are necessary, The National Standard of Canada, CAN3-Z234.1-79 shall be used as the basis of conversion.~~

#### ~~8.2.28.3.2~~ 8.3.2—Qualification

~~The Fabricator for the steel components~~Bearings shall be ~~fully approved~~supplied and fabricated by a fabricator certified by the Canadian Welding Bureau (CWB) ~~as per CSA Standard in accordance with W47.1 in Division of the Canadian Standards Association (CSA) Division 1 or 2.~~ Fabrication shall be performed in a permanent fully enclosed structure which is adequately heated. The shop temperature shall be at least 10 °C

~~Only~~The Contractor shall notify the Consultant and the Department of fabricators in his employ. The Contractor shall remain responsible for the Work of the fabricators. All terms of the Contract shall apply to the fabricators.

~~Welders, welding operators and tackers shall be CWB approved by the Canadian Welding Bureau in the particular applicable category shall be permitted to perform weldments.~~ Their qualifications shall be current and available for examination by the Consultant upon request.

#### ~~8.2.38.3.3~~ 8.3.3—Engineering Data

##### ~~8.2.3.18.3.3.1~~ 8.3.3.1 Welding Procedures

~~Welding procedures, including welding procedure datasheets approved by the Canadian Welding Bureau required for the fabrication and field installation of bearings, shall be submitted for each type of weld proposed. The welding procedures shall bear the approval of the CWB and be reviewed and accepted by the Consultant and the Department and Consultant before welding proceeds a minimum of 3 weeks prior to the commencement of fabrication.~~

##### ~~8.3.3.2~~—Shop Drawings

~~Shop drawing requirements shall be as per Section 6 of the Specifications for Bridge Construction. In addition, the following requirements shall be met:~~

##### ~~8.3.3.2~~ The Design Notes, Independent Check Notes, and Shop Drawing Submission Requirements

~~Design notes, independent check notes, and shop drawings shall be signed and sealed by the design engineer of record and by an independent checker. The design engineer of record and the independent checker shall be Professional Engineers registered in the Province of Alberta. Design notes, independent check notes and shop drawings shall be submitted to the Consultant for review and acceptance a minimum of 3 weeks in advance of the commencement of fabrication. Review comments provided by the Consultant and/or the Department shall be incorporated into the design notes, independent check notes and shop drawings and resubmitted to the Consultant for review and acceptance prior to the commencement of fabrication.~~

The design engineer of record and independent checker shall submit separate signed and sealed design notes and independent check notes. The design and independent check notes shall be presented in a legible and logical format, clearly indicate all identify material properties, dimensions, and sufficiently detailed to allow a technical review of design concepts and assumptions used. All material properties shall be confirmed and documented by the design engineer of record and independent checker prior to the commencement to fabrication.

The independent checker may be employed by the same company as the design engineer of record. The independent check must be completed fully independent of the design engineer of record, including a complete re-analysis of all aspects of the design including calculations and engineering, preferably by a methodology or computer program other than that used by the design engineer of record. The design engineer of record and independent checker shall ensure that the shop drawings are complete and accurately convey the design criteria and assumptions used in their designs.

Shop drawings shall be electronic unlocked PDF format. Each shop drawing shall include the Department's shop drawing identification block and have a sufficient blank space for the Consultant's review stamp. The Department's shop drawing identification block will be provided to the Contractor upon request. As a minimum, the following information shall be included on shop drawing submissions:

- All material properties;
- Dimensions;
- Connection attachments;
- Fasteners and accessories, the;
- Bearing identification; and
- the Load capacity information at the serviceability and ultimate limit states as follows:
  - Maximum vertical permanent and total load;
  - Maximum lateral load and corresponding vertical load; and
  - Maximum rotational capacity about any horizontal axis and about the vertical axis at the centre of the bearing.

When bearings for more than one bridge are included, individual Design notes, independent check notes, and shop and erection drawings shall be submitted for each bridge structure contained in the Contract.

#### 8.3.3.3 — Mill Certificates and Quality Assurance Testing

Mill certificates and quality assurance—The design notes, independent check notes, and shop drawings will be reviewed by the Consultant solely to ascertain general conformance with codes and specifications. The Consultant's review and acceptance shall not be considered as relieving the Contractor of the responsibility for completing the Work in accordance with the Contract requirements.

The Contractor shall incorporate as-built construction conditions into design notes, independent check notes, and shop drawings. One paper copy and one electronic copy (PDF format) of as-built design notes, independent check notes, and shop drawings shall be submitted to the Consultant within 3 weeks of construction completion.

#### 8.3.3.3 Mill Test Reports

Mill test results reports shall be provided to the Consultant for all materials and fabricated components in English and submitted to the Consultant for review and acceptance 3 weeks prior to shipping commencement of the finished bearings fabrication.

Where mill test reports originate from the facility of manufacture a mill outside Canada or the United States of America, the Contractor shall have mill test reports verified by a certified laboratory in Canada by testing the material to the specified material standards, including boron content. The testing laboratory shall be certified to ISO/IEC 17025 by an organization accredited by the Standards Council of Canada for the tests required. Samples for testing shall be collected by personnel employed by the certified laboratory. A verification letter shall be provided by the certified laboratory that includes at a minimum, the applicable mill test reports, testing standards, date of verification testing, and declaration of material compliance with Contract requirements. The verification letter shall be signed by an authorized officer of the certified laboratory.

#### 8.2.48.3.4 8.3.4—Materials

All materials shall be new ~~and unused~~, with no reclaimed material incorporated in the finished bearing.

#### 8.2.4.18.3.4.1 Steel

##### 8.3.4.1—Steel

The steel laminates within ~~reinforced laminated~~ elastomeric bearings shall be rolled mild steel with minimum yield strength of 230 MPa. The steel for base plate, keeper bars, pintels, ~~pot plates, piston plates~~, and shims shall conform to the requirements of CSA G40.24/21M Grade 300W ~~or 350W~~. The steel for sole ~~plate, top bearing plate~~ plates and fixed ~~rocker~~ rockers shall be ~~as per in accordance with the site specific drawings. Drawings.~~

8.3.4.2 Stainless Steel with a boron content exceeding 0.0008% will not be permitted.

#### 8.2.4.28.3.4.2 Stainless Steel

Stainless steel sheets shall conform to the requirements of the American Iron and Steel Institute (AISI) Type 304, no. 8 mirror (0.2 µm) finish. The chemical and mechanical properties shall conform to the requirements of ASTM ~~A-240~~ A240M. Stainless steel sheets shall have a minimum thickness of 3.2 mm.

##### 8.3.4.3—Brass

8.3.4.3 Brass

Brass sealing rings for ~~confined elastomer~~pot bearings shall be according to ASTM B36M, half-hard.

~~8.2.4.38.3.4.4~~ 8.3.4.4 Elastomer

Cured elastomeric compounds shall be low temperature Grade 5 and meet the ~~physical and low temperature brittleness~~minimum requirements listed in Table ~~1 and Section 8.8.4X1~~ of AASHTO M251-06. ~~#Cured elastomeric compounds~~ shall have 60 durometer hardness shore A for elastomeric bearing pads (laminated and plain) and 50~~±5~~ durometer hardness shore A for pot bearings- (elastomeric disc).

Cured elastomeric compounds for fully integral abutments and piers shall be low temperature Grade 3, 4, or 5 and meet the ~~physical and low temperature brittleness~~minimum requirements listed in Table ~~1 and Section 8.8.4X1~~ of AASHTO M251-06. ~~# Cured elastomeric compounds for fully integral abutments and piers~~ shall have 50~~±5~~ durometer hardness shore A.

~~8.3.4.5~~ PTFE

Cured elastomeric compounds shall also meet the requirements of ASTM D2240 for low temperature crystallinity increase in hardness at an exposure of -25°C for 168 hours.

8.3.4.5 PTFE

PTFE shall be unfilled, 100% virgin polymer. ~~It shall conform~~ conforming to ~~Section~~Subsection 18.8.2.5 ~~Unfilled PTFE Sheet of the 20092010~~ AASHTO LRFD Bridge Construction Specifications including all interim revisions. Material used as the mating surface for guides for lateral restraint may be one of the following:

- Unfilled PTFE.
- PTFE filled with up to 15% by mass of glass fibres.

~~8.2.4.48.3.4.6~~ 8.3.4.6 Lubricant

Lubricant shall be silicone grease, effective to -40 °C, and comply with U.S. Department of Defense specification MIL-S-8660C.

~~8.2.4.58.3.4.7~~ 8.3.4.7 Adhesives

Adhesive for bonding PTFE to metal shall be an epoxy resin producing a bond with a minimum peel strength of 4 N/mm, when tested according to ASTM ~~D-429~~D429, Method B. Adhesives shall not degrade in the service environment.

~~8.3.4.8~~ Base Plate Corrosion Protection

~~Bearing base plate corrosion protection shall be as per Section 12 of the Specifications for Bridge Construction.~~

8.3.4.8 ~~8.3.4.9~~—Anchor Rods and Connecting Bolts

Anchor rods and connecting bolts shall be in accordance with Table 8-2, Anchor Rod and Connecting Bolt Requirements.

**For anchor rods ~~Table 8-2: Anchor Rod~~ and Connecting bolts, the following material properties shall be used: ~~Bolt Requirements~~**

Description	Grades
<u>For stainless steel bearing anchor rods in contact with black steel.</u>	<u>Stainless steel AISI Type 316 (Fy = 290 MPa based on 0.2% offset)</u>
Galvanized mild steel anchor rods in contact with galvanized bearing plates.	Galvanized CSA G40.21M Grade 300W or ASTM A307
Galvanized high strength anchor rods in contact with galvanized bearing plates	Galvanized ASTM A193 GRADE B7 (Fy=725 MPa, Fu=860 MPa). <del>Note galvanizing of high strength steel requires special procedures; refer to Standard Drawing S1642.</del>
Bolts connecting galvanized bearing components.	<ul style="list-style-type: none"> <li>Galvanized 22 mm diameter <u>ASTM F3125 (rotational capacity testing required) Grade A325/A325M Type 1 heavy hex style bolts;</u></li> <li>Galvanized nuts <u>ASTM A563/A563M;</u> and</li> <li>Galvanized hardened washers <u>ASTM F436/F436M</u></li> </ul>

8.2.58.3.5 ~~8.3.5~~—Welding8.2.5.18.3.5.1 ~~8.3.5.1~~ Filler Metals & Welding Processes

Low hydrogen filler, fluxes and low hydrogen welding practices shall be used ~~throughout. The deposited weld metal shall provide strength, durability, impact toughness, and corrosion resistance equivalent to base metal.~~ The low hydrogen covering and flux shall be protected and stored as specified by AWS Standard D1.5. ~~Flux cored welding or use of cored filler wires in the submerged arc process or shielding gas processes are not considered as conforming to low hydrogen practice. These methods will not be permitted. However metal core welding process utilizing low hydrogen electrodes with AWS designation of H4 will be allowed. The deposited weld metal shall provide strength, durability, impact toughness and corrosion resistance equivalent to base metal.~~ All electrodes, electrode/flux combinations, and electrode/shielding gas combinations shall be CSA certified.

Only the following welding processes and associated consumables shall be used:

8.3.5.1.1 Submerged Arc Welding (SAW)

All welds shall be made by a semi or fully automatic submerged arc process acceptable to the Department.

The submerged arc welding process may be used for flat and horizontal position welds.

All electrodes and fluxes shall conform to the diffusible hydrogen requirements of AWS D1.5 filler metal hydrogen designator H8 or lower. Use of cored filler wires in the submerged arc welding process or shielding gas process will not be permitted.

8.3.5.1.2 Shielded Metal Arc Welding (SMAW)

All electrodes and fluxes shall conform to the diffusible hydrogen requirements of AWS D1.5 filler metal hydrogen designator H4.

8.3.5.1.3 Metal Core Arc Welding (MCAW)

All electrodes shall conform to the diffusible hydrogen requirements of AWS D1.5 filler metal hydrogen designator H4

Field ~~application of welding using the~~ metal core arc welding ~~is process will~~ not ~~be~~ permitted.

~~8.2.5.28.3.5.2~~ 8.3.5.2 Cleaning Prior to Welding

Weld areas must be clean, free of mill scale, dirt, grease, and other contaminants prior to welding. For multi-pass welds, previously deposited weld metal shall also be thoroughly cleaned prior to depositing subsequent passes.

~~8.2.5.38.3.5.3~~ 8.3.5.3 Tack and Temporary Welds

Tack and temporary welds shall not be allowed unless they are to be incorporated in the final weld. Tack welds, where allowed, shall be of a minimum length of four times the nominal size of the weld and length shall not exceed 15 times the weld size, and shall be subject to the same quality requirements as the final welds. Tack welds shall be sufficiently ground out prior to final weld in order to obtain a uniform weld bead. Cracked tack welds shall be completely removed prior to re-welding.

8.3.5.4 Methods of Weldment Repair8.3.5.4 Run-off Tabs

Run-off tabs shall be used at the ends of all welds that terminate at the edge of a member. The thickness and shape of the tabs shall replicate the joint detail being welded and shall be a minimum of 100 mm long unless greater length is required for satisfactory work. They shall be tack welded only to that portion of the material that will not remain a part of the structure, or where the tack will be welded over and fused into the final joint. After welding, the tabs are to be removed by flame cutting, not by breaking off.

8.3.5.5 Preheat and Interpass Temperatures

Preheat and interpass temperature requirements shall be as per AWS D1.5, except that all welds to girder flanges shall be preheated to a minimum temperature of 100 °C unless a higher temperature is required by AWS D1.5 for the flange thickness. The preheat temperature shall be measured 75 mm from the point of welding on the opposite where the weld is being applied.

8.3.5.6 Grinding of Welds

Welds that are sufficiently smooth with a neat appearance and uniform profile, as determined by the Consultant, will not require grinding. Welds not conforming to an acceptable profile shall be ground to the proper profile without damaging or substantial removal of the base metal.

Grinding shall be smooth and parallel to the line of stress. Caution shall be exercised to prevent over grinding. Over grinding that results in reduced thickness of the base metal or size of the weld will not be permitted. Acceptability of the welds without grinding will be determined by the Consultant.

8.3.5.7 Submission of Repair Procedures

The Contractor shall submit repair procedures for damaged base metal and unsatisfactory weldments shall be submitted to the Consultant and the Department for review and acceptance by the Department and Consultant prior to repair work commencing commencement of the repair work. The repair procedures shall be signed and sealed by an experienced welding engineer registered as a Professional Engineer in the Province of Alberta.

~~8.2.5.48.3.5.8~~ 8.3.5.5 Arc Strikes

Arc strikes will not be permitted. In the event of an isolated accidental arc strikes, the Contractor shall submit to the Department and Consultant for review and acceptance strike, a proposed repair procedure. shall be submitted in accordance with Subsection 6.2.5.7, Submission of Repair Procedures. At a minimum, the repair procedure shall include the complete grinding out of the crater produced by the arc strike. The repair procedure shall also include MPI and hardness testing of the affected area. Hardness of the repaired area shall conform to the requirements of Subsection 6.2.8.11, Hardness Tests. These areas will be examined by the Consultant to ensure complete removal of the metal in the affected area.

~~8.2.5.58.3.5.9~~ 8.3.5.6 Plug and Slot Welds

Plug welds or slot welds ~~will~~shall not be permitted.

~~8.2.68.3.6~~ 8.3.6 Fabrication

~~Fabrication shall be performed in a fully enclosed area which is adequately heated. The shop temperature shall be at least 10°C.~~



~~(a) A pre-fabrication meeting is required for the supply and fabrication of bearings. The pre-fabrication meeting shall be held at the fabrication facility and the Contractor shall ensure that the fabrication superintendent, fabrication manager, and supervisors directly involved in the Work are in attendance. The meeting shall not occur until shop drawings, design notes and independent check notes, and welding procedures have been reviewed and accepted by the Consultant. The date of the pre-fabrication meeting shall be reviewed and accepted by the Consultant and the Department and proposed a minimum of 2 weeks prior to the anticipated date.~~

#### 8.2.6.18.3.6.1 Plain Elastomeric Bearings

Plain elastomeric bearing pads shall be moulded individually, cut from moulded strips or slabs of the required thickness, or extruded and cut to length.

#### 8.2.6.28.3.6.2 ~~(b)~~ Laminated Elastomeric Bearings

Laminated elastomeric bearings shall be moulded under pressure as a single unit and heated in moulds that have a smooth surface finish.

The steel laminates shall be of uniform 3.2 mm nominal thickness without any sharp edges. The bond between the elastomer and the metalsteel laminates shall be such that when a sample is tested for separation, failure shall occur within the elastomer and not between the elastomer and metalsteel laminate. The top 10 mm galvanized laminate for sliding bearings shall have a 2.5 mm recess. The recessed surface shall be machined as per ~~clause 8.3.6.1 of the Specifications for Bridge Construction.~~ Subsection 8.3.6.5, Machining.

#### 8.2.6.38.3.6.3 ~~(c)~~ Pot Bearings

Stainless steel sheets in contact with PTFE shall be continuously welded around the perimeter to its backing plate to prevent ingress of moisture. The weld shall be clean, uniform, and without overlaps and located outside the area in contact with PTFE.

The threaded portion of the bolts shall be coated with silicone grease prior to installation.

Virgin or glass filled PTFE elements shall be recessed in a rigid backing material and shall be bonded over the entire area with an adhesive. The rigid backing material shall be grit blasted and cleaned with oil free compressed air prior to applying the adhesive.

The PTFE elements used as mating surfaces for guides for lateral restraint shall extend to within 10 mm from the ends of the backing plates.

#### 8.2.6.48.3.6.4 ~~(d)~~ Fixed Steel Plate Rocker Bearings

The curved surface of steel rocker ~~bearing~~bearings shall be machined as per ~~clause 8.3.6.1 of the Specifications for Bridge Construction.~~ Subsection 8.3.6.5, Machining.

~~8.2.6.5~~ 8.3.6.1 Machining

Machining shall be done after welding. All metal to metal contact surfaces shall be machined.

For pot bearings, the pots and pistons shall be machined from solid metal plate or castings. There shall be no openings or discontinuities in the metal surfaces in contact with the confined elastomer or PTFE.

The surface finish of metal plate in contact with any metal plate or confined elastomer in pot and sliding laminated elastomeric bearings shall be machined to a surface finish of 6.4 µm and a flatness tolerance of 0.001 x bearing dimension.

~~8.2.6.6~~ 8.3.6.2 Identification

Each bearing shall be marked with the fabricator's name, date of manufacture and unique identification number. The characters shall be not less than 10 mm in height.

8.3.6.3 Coating~~8.3.6.7~~ Galvanizing

~~The fabricator shall provide a smooth finish on the site specific drawings, except weathering steel (CSA G40.21 350 A all edges and 350 AT) surfaces, and stainless steel, remove all weld spatters, and all welding flux residue from the steel components prior to galvanizing.~~

Factors contributing to galvanization-induced cracking shall be minimized. Galvanizing shall be by the hot dip galvanized method, after fabrication, in accordance with the current edition of ASTM A123/A123M Standard Specification for Zinc (Hot-Dip Galvanized) Coatings on Iron and Steel Products and ASTM F2329 Standard Specification for Zinc Coating Hot-Dip Requirements for Application to Carbon and Alloy Steel Bolts, Screws, Washers, Nuts, and Special Threaded Fasteners, and as modified in this specification.

~~For pot bearings, The cleaning and pickling procedure of high strength ASTM A193 Grade B7 anchor rods shall be modified as follows prior to hot-dip galvanizing:~~

- Brush blast to remove mill scale and oil after threading ends;
- Flash pickle up to 5 minutes; and
- Quick dry prior to hot-dip galvanizing (not stored in flux or acid rinse).

The modified anchor rod cleaning and pickling procedure shall be completed in the presence of the Consultant prior to hot-dip galvanizing.

Pot and piston plates of pot bearings, except the surfaces in contact with the elastomer, shall be metallized ~~as per~~ in accordance with ASTM A780, Method A3. The thickness of metallizing shall not be less than 180 microns.

~~Repair of galvanizing shall only be done if bare areas are infrequent, small, and suitable for repair. A detailed repair procedure shall be submitted for review prior to its use. It should be noted that Repairs may require complete removal of the galvanized coating and re-galvanizing. Repair shall be in compliance with ASTM A780, Method A3 Metallizing. However repair for areas not exceeding 100 mm<sup>2</sup> may be done in accordance with ASTM Method A1 "Repair Using Zinc-Based Alloy". The thickness of the coating for both methods shall be 180 µm, and the repair tested for adhesion. The finished appearance shall be similar to the adjacent galvanizing. The Consultant will determine the acceptability of repaired areas.~~

Galvanized contact surfaces of bolted connections shall be hand wire brushed to a Class A slip coefficient surface condition. Slip coefficients surface conditions shall meet the requirements of Table 10.9 of CSA S6.

~~Galvanized sole plates, slider plates and rocker plates bolted to the bottom flanges of weathering steel girders shall use galvanized A325 bolts. The bolt layout, size and configuration shall be as detailed on contract drawings. Girder bottom flanges at bearing connections shall be prime coated all around (bottom, top and edges) to 100 mm beyond the sole plate with an approved organic zinc epoxy primer having a certified Class B slip coefficient. The galvanized top surface of the bearings plates shall be hand wire brushed to a Class C slip coefficient surface condition. Slip coefficients surface conditions shall meet the requirements of CAN/CSA S6-06 Table 10.9. ASTM F3125 Grade A325/A325M Type 1 heavy hex style bolts. The bolt layout, size and configuration shall be as detailed on the Drawings.~~

Repair of galvanizing shall be completed in accordance ASTM A780, Method A3 "Metallizing" and will only be permitted when the repair areas are small and infrequent as determined by the Consultant. Repair areas less than 100 mm<sup>2</sup> in area may be completed in accordance with ASTM A780, Method A1 "Repair Using Zinc-Based Alloy". The thickness of the coating for both methods shall be 180 µm, and the repair tested for adhesion. A detailed repair procedure shall be submitted for review and acceptance by the Consultant prior to commencement of the work. Repairs may require complete removal of the galvanized coating and re-galvanizing. The finished appearance shall be similar to the adjacent galvanizing as determined by the Consultant.

Galvanized material shall be stacked or bundled and stored to prevent wet storage stain as per the American Hot Dip Galvanizers Association (AHDGA) publication "Wet Storage Stain". Any evidence of wet storage stain shall be removed to the satisfaction of the Consultant.

#### 8.3.6.8 Base Plate Corrosion Protection~~8.3.6.4~~

The bottom surface of each base plate shall be protected by a medium grey colour barrier coating accepted by the Consultant, to prevent contact between the zinc and the concrete. The galvanized surface must be roughened prior to application of barrier coating. The surface preparation of the galvanized surface and the dry film thickness (DFT) of the coating shall be in accordance with the coating Manufacturer's recommendations.

The Consultant will test the adhesion of fully cured coating as per ASTM D3359 “Standard Test Methods for Measuring Adhesion by Tape Test”. The method selected for testing (Method A or B) shall depend on the dry film thickness of the coating. The coating manufacturer’s product data sheets shall be provided to the Consultant prior to the application of the coating. The adhesion test result shall meet a minimum of “4B” classification i.e. a maximum allowable flaking of 5%.

#### ~~8.2.6.7~~ 8.3.6.9 Tolerances

Plain and laminated elastomeric bearing fabrication tolerances shall ~~be as per meet the requirements of~~ AASHTO ~~Standard~~ M251-06.

Pot bearing fabrication tolerances shall be as follows:

- ~~a)~~ The deviation from flatness of PTFE surfaces shall not exceed:
  - 0.2 mm, when the diameter or diagonal is equal to or less than 800 mm.
  - 0.00025 of the diameter or diagonal, when the diameter or diagonal is greater than 800 mm.
- ~~b)~~ — The deviation from flatness of stainless steel in contact with PTFE for planeplain surfaces and from the theoretical surface for spherical surfaces shall not exceed:
  - 0.0003 LH mm for a rectangular PTFE element.
  - 0.0006 RH mm for a circular PTFE element

where:  
 L = the greater plan dimension for a rectangular bearing,  
 R = the radius of a circular bearing, and,  
 H = the free height of PTFE element
- ~~c)~~ — For confined elastomerpot bearings, the tolerance of fit between the piston and the pot shall be +0.75 to +1.25 mm. The inside diameter of the pot cylinder shall be the same as the nominal diameter of the elastomer and shall be machined to a tolerance of:
  - 0 to +0.125 mm for diameters up to and including 500 mm.
  - 0 to +0.175 mm for diameters over 500 mm.
- ~~d)~~ — The plan dimensions of the recess for PTFE shall be the same as the nominal plan dimensions of the PTFE and shall be machined to a tolerance of 0 to +0.2% of the diameter or diagonal.
  - Overall bearing plan dimension ~~±~~ ± 3 mm
  - Overall bearing height ~~±~~ ± 3 mm
  - Machined surface dimensions ~~±~~ ± 0.4 mm
- ~~e)~~ — Elastomeric components shall meet the following requirements~~tolerances~~:

- Diameter: ~~-~~ 0.0 to -1.5 mm for diameters  $\leq 500$  mm  
0.0 to -2.0 mm for diameters  $> 500$  mm
- Thickness 0.0 to +1.0 mm
- ~~f)~~ — Brass rings shall meet the following ~~requirements~~ tolerances:
  - Difference between internal diameter of brass ring and diameter of recess in the moulded elastomer shall be 0 to + 0.5 mm.
  - Difference between sum of thicknesses of brass rings and recess depth in the moulded elastomer 0 to + 0.25 mm
- ~~g)~~ — Recessed Guide Bars shall meet the requirements of the American Standard Clearance Locational Fit Class LC3 according to ANSI B4.1.
- ~~h)~~ — Guides for lateral restraints shall have a 0.50 mm  $\pm$  0.25 mm gap between metal restraints surfaces and mating PTFE elements.
- ~~i)~~ — PTFE components shall meet the following requirements:
  - The plan dimension of the PTFE shall be 0 to -0.2% of the diameter or diagonal ~~difference between internal diameter of brass ring and diameter of recess in the moulded elastomer shall be 0 to +0.5 mm.~~
  - The thickness of the PTFE shall be within 0 to +10.0% of the design thickness.
  - The depth of recess of the PTFE shall be 0 to +0.3 mm of the design depth

### ~~8.2.78.3.7~~ 8.3.7 — Testing and Inspection

#### ~~8.3.7.1~~ — Testing by the Contractor

~~The Contractor shall be responsible for quality control and quality assurance testing required to ensure the work meets the design parameters and specification requirements.~~

~~Any quality control/quality assurance testing and inspection records made by the Contractor shall be open to the Consultant for auditing.~~

#### 8.3.7.1 Access

The Consultant shall have full access to all parts of the Work at all times. When required by the Consultant, the Contractor shall provide needed manpower for assistance in performing inspection duties.

#### 8.3.7.2 Responsibility

It is the Contractor's responsibility to ensure that the Work is completed in accordance with the Contract requirements. Any inspection and/or testing completed by the Consultant, review and acceptance by the Consultant, shall not be considered as relieving the Contractor of the responsibility for completing the Work in accordance with the Contract.

The Contractor shall be responsible for all travel, boarding and lodging costs incurred by the Consultant to inspect bearings being fabricated outside the Province of Alberta. The cost shall also include for a Department's representative to attend the pre-fabrication meeting and one additional trip during the course of fabrication.

### 8.3.7.3 Testing by the Contractor

The Contractor shall engage an independent ~~accredited~~CSA certified testing company at his expense to perform testing of bearing materials and the ~~finished~~completed bearings.

~~The testing shall meet the acceptance criteria outlined in the specifications. The results~~The Contractor shall perform magnetic particle inspection of at least 25% of all fillet and partial penetration welds. Non-destructive examination by MPI shall be forwarded in accordance with ASTM Standard E-709.

~~Testing and inspection records shall be open to the Consultant for review prior to shipping the bearings to the site. The Contractor shall also submit teupon request.~~

~~Testing, inspection and related costs incurred by the Consultant prior to shipping to the site, the manufacturer's certification, as a written affidavit, that the material supplied meets the contract requirements. result of defective work shall be paid for by the Contractor.~~

### ~~8.2.7.1.18.3.7.3.1~~ 8.3.7.1.1 — Elastomeric Bearings

~~Testing of Plain~~ elastomeric compounds~~bearings~~ shall be ~~completed~~tested in accordance with Section 8 of AASHTO M251-06. ~~Testing of~~; however the completed~~material shall conform to the specified requirements of Table X1. The testing specified in Subsections 8.8 and 8.9 of AASHTO M251-06 is not required for plain elastomeric bearings.~~

Laminated elastomeric bearings shall be tested in accordance with ~~AASHTO M251-06 with the exception that contrary to clauses 8.8.1 and 8.8.2, testing of all bearings is required. The optional testing described in Section 8 of AASHTO M251-06; however the material shall conform to the specified requirements of Table X1. The testing specified in Subsection 8.9 of AASHTO M251-06 is not required.~~

for laminated bearings. A minimum of two sample laminated bearings shall be cut and tested for shear modulus. The increment in compressive deformation of laminated bearings shall not exceed 0.05 of the effective rubber thickness, when the bearing load is increased from an initial pressure of 1.5 MPa to a pressure of 7 MPa when tested as per the requirements of ~~Section~~Subsection 9.1, of ~~the~~ AASHTO M251-06. The dimensional tolerances for each bearing shall be checked and included with the testing report.

8.3.7.1.2 — The hardness of elastomer shall be tested and the results included with the test report.

---

#### 8.2.7.1.28.3.7.3.2 Pot Bearings

Testing of elastomeric compounds shall be ~~completed~~ in accordance with AASHTO M251-06. Testing of the ~~finished~~completed bearings shall ~~be completed~~ in accordance with the requirements of Subsection 18.3.4 of the ~~2009~~2010 AASHTO LRFD Bridge Construction Specifications including all interim revisions. The long-term deterioration test described in Subsection 18.3.4.4.3 is not required. The proof load test described in Subsection 18.3.4.4.4 shall be ~~carried out as per~~completed in accordance with the long-term proof load test requirements.

#### 8.3.7.2 Testing by the Consultant

##### 8.3.7.4 Any additional or supplemental inspections that

The Consultant may complete quality assurance testing and inspection and the Contractor shall accommodate all the Consultant requirements to complete testing and inspection.

##### 8.3.7.5 Notification to Ship

The Contractor shall notify the Consultant 72 hours prior to shipment to facilitate inspection and acceptance of the bearings. Bearings shall not be required will be performed shipped until they have been reviewed and accepted by the Consultant. Review and acceptance of bearings at the fabrication facility by the Consultant or his will not relieve the Contractor of his full responsibility to meet the requirements of these specifications.

Bearings that have not been inspected at the fabrication facility will not be paid for until they been inspected, reviewed and accepted by the Consultant. The Contractor shall be responsible for all costs incurred by the Consultant for inspection of the bearings not inspected at the fabrication facility.

##### 8.3.7.6 Fabrication Outside of Canada

All testing and inspection requirements specified in Subsection 8.3.7, Testing and Inspection, shall be completed at the fabrication facility and all costs incurred by the Consultant and their designated testing agencies at the Consultant's expense, and the Department shall be paid for by the Contractor.

The Contractor shall ensure that adequate notice for inspection and testing be given to the Consultant and that access to the work is assured at all times. When required by the Consultant, the Contractor shall provide needed manpower for assistance in checking layout and performing inspection duties.

~~8.3.8—All components fabricated outside of Canada shall be shipped to a shop located in Canada that is certified by CWB in accordance with CSA W47.1 to Division 1 or 2 for re-inspection and testing. The components shall be in a condition that facilitates all re-inspection and testing requirements. The re-inspection and testing at the Canadian shop shall be completed in accordance with Subsection 8.3.7, Testing and Inspection. The Contractor shall also arrange for inspection by a CSA 178.2 Level III certified welding inspector accredited with W47.1/W59 to inspect:~~

- ~~• All components to ensure that they were undamaged during transportation;~~
- ~~• 100% of all fillet and partial penetration welds using magnetic particle inspection in accordance with Subsection 8.3.7.3, Testing by the Contractor;~~

~~Components shall not be shipped from the Canadian shop until all requirements have been met and the Work has been reviewed and accepted by the Consultant.~~

~~The Contractor shall be responsible for all re-inspection and testing costs, including all cost incurred by the Consultant and the Department.~~

~~The Contractor shall have no claim against the Department resulting from delays caused by these requirements.~~

#### ~~8.3.8~~ Approved Pot Bearing SuppliersFabricators

~~Pot bearings shall be supplied and fabricated by one of the approved pot bearing fabricators listed on the Department's Product List.~~

~~The following Pot Bearing Manufacturers have been approved for the use of their products, based on compliance with the design parameters and specification requirements:~~

- ~~• Glacier~~
- ~~• Goodco Z-Tech~~
- ~~• LCL-Bridge~~

#### ~~8.38.4~~ 8.4—Installation

##### ~~8.3.18.4.1~~ 8.4.1—General

~~The Contractor shall submit to the Consultant, for review and acceptance a detailed bearing installation procedure~~ fourto the Consultant for review and acceptance 4 weeks in advanceprior to commencement ~~of the scheduled start of installationWork.~~ The installation procedure shall include ~~all~~ drawings and documents necessary to describe the following:

- Survey information for location and elevation of grout pads, and anchor rod voids;
- Placing of anchor rods and bearings;
- Grouting of anchor rods;
- Methods of forming, placing, curing, and sealing of grout pads;
- Enclosure and system of heating for grouting in cold weather;



- 8.4.2—Setting expansion bearings for correct temperature; and
- Setting bearings to correct grade and elevation.

#### 8.3.28.4.2 Bearing and Anchorage

~~Masonry Concrete surfaces on which bearing plates, pads or shims are placed shall not be placed upon bridge seat bearing areas which are improperly finished, deformed or irregular. Bearing plates shall be set level in their exact position accordance with Subsection 4.25.8, Surface Finish under Bearings.~~

The Contractor shall remove all materials used to form anchor rod void forming materials, and accurately set the anchor rods, except where the rods were cast into the concrete. Any residues on the voids. Foreign materials on concrete surfaces, such as oils, grease or other contaminants, shall be removed by sandblasting prior to installation of anchor rods.

When bearings are detailed in conjunction with grout pockets in the substructure, the bearings shall be set accurately on galvanized steel shim plates. Galvanized steel shim plates shall be located such that a minimum of 75 mm of grout cover is provided from shims to the grout edge. When grout pockets are not detailed on the Drawings, the bearing shall be set on the finished concrete surface in exact position and have full and even bearing.

Base plates shall be set to the positions indicated on the Drawings. Anchor rods and bearings shall be positioned in accordance with the bearing setting tables shown on the Drawings and the girder temperature at the time of grouting. Where nuts are specified on top of expansion bearing anchor rods, they shall be adjusted to permit movement. Top of the bearing sole plate shall be within a tolerance of  $\pm 3$  mm of the correct elevation prior to girder erection.

Anchor rods and bearing grout pads shall not be grouted until girder erection of the entire superstructure is completed unless otherwise approved by the Consultant and the Department. ~~All methods and materials for setting anchor rods and constructing bearing pads shall be subject to the Consultant's review and acceptance. The location of the anchor rods, in relation to the slotted holes in the expansion shoes, shall correspond with the temperature at the time of erection. The nuts on the anchor rods, at the expansion ends of spans, shall be adjusted to permit free movement of the spans.~~

~~When bearings are detailed in conjunction with grout pockets in the substructure, the bearings shall be set accurately on galvanized steel shims. The shims shall be located such that a minimum of 75 mm grout coverage is provided. When grout pockets are not detailed, the bearing shall be set on the properly finished bearing areas in exact position and shall have a full and even bearing on the concrete.~~

When required, field welding adjacent to elastomeric padsbearings shall be performed with care to avoid completed such that damage to the elastomer. ~~The temperature of the steel adjacent to the elastomer should be kept below 120°C. The distance between the weld and the elastomer should be bearing does not occur. Damaged elastomeric bearings, as determined by the Consultant, shall be replaced by the Contractor at least 40 mm his expense.~~

~~Top of the bearing sole plate shall be within a tolerance of  $\pm 3$  mm of the correct elevation prior to girder erection.~~

Sole plates shall be bolted or welded to girders in accordance with the ~~contract~~ Drawings. Attachment of sole plates to girders by welding shall be in the longitudinal direction along the edge of the bottom flange or shoe plate. ~~Transverse welding shall not be permitted.~~ Transverse ends shall be sealed with Sikaflex 1a or an approved equivalent caulking material. Welding of the transverse edge will not be permitted.

Galvanizing or metallizing damaged during field ~~operation~~ operations shall be repaired by metallizing as per ~~ASTM A780 Method A3, Subsection 8.3.6.7, Galvanizing.~~

#### 8.4.3 ~~8.4.3~~ Grouting of Anchor Rod Voids and Bearing Grout Pads

Grout used for the grouting of anchor rod voids and bearing grout pads shall be selected from the Alberta Transportation Product List, Non-Shrink Grout category.

Anchor rod voids and bearing grout pads shall be grouted after the entire superstructure has been erected and prior to casting deck concrete.

~~The Contractor shall fill the anchor rod voids and construct the grout pads using Sika 212 flowable grout or an approved equivalent. method of forming and pouring the grout shall be submitted to the Consultant for review and acceptance. Dry-pack methods of constructing grout pads will not be accepted. Filling of anchor rod voids and construction of grout pads shall be done by workers competent in this work.~~

Grout shall be packaged in waterproof containers with the production date and shelf life of the material shown. It shall be mixed, and placed, ~~and cured~~ in strict accordance with the manufacturer's recommendations stated on their published product data sheet.

The Contractor shall utilize experienced ACI or CSA certified testers to test the compressive strength of the grout: in accordance with CSA A23.2-1B. A set of compressive strength cubes shall be taken to represent each days production or  $0.25 \text{ m}^3$ , whichever is more frequent. All test results shall be provided to the Consultant. ~~Prior to casting deck concrete, the~~ The average minimum compressive strength of 3 cubes at 28 days shall be a 30 MPa measured. ~~Failure to meet the minimum specified compressive strength will result in accordance with CSA A23.2-1B.~~ A type 1C sealer shall be supplied and applied to the exposed grout pad surfaces in accordance with Section 4 of being removed and replaced at the Specifications for Bridge Construction Contractor's expense.

~~8.~~ Grout shall be wet cured for a minimum of 3 days with two layers of clean, saturated Nillex 4504 white coloured filter fabric or an approved equivalent. Water used for wet curing shall be clean and acceptable to the Consultant.

Sealer shall be applied to the exposed grout pad surfaces in accordance with Subsection 4.4 ——— 26, Type 1c Sealer.

8.3.2.18.4.3.1 Grouting in Cold Weather

When the daily minimum air temperature or the temperature of the girders, bearings or substructure concrete in the immediate area of the grouting is, or is expected to be below 5°C during the placing and curing period, the following ~~provisions for cold weather grouting shall be applied~~ additional requirements shall be included in the Contractor's bearing installation procedure:

- ~~(a)~~ — Before grouting, adequate preheat shall be provided to raise the temperature of the adjacent areas of the girders, bearings and substructure concrete to at least 15°C.
- ~~(b)~~ — Temperature of the grout during placing shall be between 10°C and 25°C.
- ~~(c)~~ — The grout pads shall be enclosed and kept at 15°C to 25°C for a minimum of five days. The enclosure shall meet the requirements of ~~Section 4 of the Specifications for Bridge Construction for~~ Subsection 4.21, Concreting in Cold Weather.

8.48.5 8.4.5—Warranty

The Contractor shall provide a written five year Warranty for the bearing assemblies. The Warranty period shall commence on the date of Contract Completion, and shall provide for complete replacement of the bearing assemblies including but not limited to, all necessary traffic control, superstructure jacking, grout pads, concrete, and attachments to girders as required at no cost to the Department if any portion of the bearing assembly fails to perform satisfactorily within the designed range of movement or loading.

8.58.6 8.4.6—Payment8.6.1 Supply and Delivery

Payment for the supply and delivery of bearings will be made at the lump sum ~~price~~ prices bid ~~and shall include for~~ “Bearings – Supply and Delivery” for the types and sizes specified, and will be full compensation for the ~~cost of furnishing supply and fabrication; loading; hauling to the project site; unloading; and all materials, labour, tools, equipment, tools and incidentals necessary for fabrication and delivery to complete the bridge site. Payment will be made~~ Work as shown on the Drawings and to a maximum the satisfaction of the Consultant.

90% of the ~~bid lump sum~~ price ~~when bid will be paid once~~ the bearings ~~are~~ have been acceptably supplied and delivered ~~to the bridge site.~~ The remaining 10% of the ~~lump sum price~~ bid ~~price~~ will be ~~made as paid once~~ the bearings ~~are~~ have been acceptably installed.

8.6.2 Installation

Payment for the installation of bearings, ~~including grouting,~~ will be made at the lump sum price bid ~~for~~ “Bearings - Install”, and shall include will be full compensation for ~~the cost~~ installation of the bearings; the supply and placement of furnishing grout; and all materials, labour, tools, equipment, tools and incidentals necessary to ~~acceptably complete installation.~~ complete the Work as shown on the Drawings and to the satisfaction of the Consultant.

All costs associated with temporary supports and ~~the associated material, labour, tools, equipment required to stabilize~~ superstructure ~~components prior to grouting~~stabilization will be considered incidental to the Work, and no separate or additional payment will be made.

All costs associated with grouting in cold weather, when required, will be considered incidental to the Work, and no separate or additional payment will be made.

STANDARD SPECIFICATIONS FOR BRIDGE CONSTRUCTION

**SECTION 9 DRAIN ~~TROUGH~~ ~~TERMINAL PROTECTION~~ TROUGHS**

TABLE OF CONTENTS

<b>9.1</b>	<b>General.....</b>	<b>9-1</b>
<b>9.2</b>	<b>Concrete.....</b>	<b>9-1</b>
<b>9.3</b>	<b>Reinforcing Steel.....</b>	<b>9-1</b>
<b>9.4</b>	<b>Heavy Rock Riprap.....</b>	<b>9-2</b>
<b>9.5</b>	<b>Geotextile Filter Fabric.....</b>	<b>9-2</b>
<b>9.6</b>	<b>Site Restoration.....</b>	<b>9-2</b>
<b>9.7</b>	<b>Measurement and Payment.....</b>	<b>9-2</b>



## 9.1 General

~~This specification is for the construction of concrete or heavy rock riprap drain troughs, including drain trough collectors, terminal protection shall be constructed with burlap or reinforced polyethylene bags filled approximately two-thirds full of fresh Class B Concrete, and all excavation, trimming and placed on a shaped backfill, and prepared foundation.~~

~~Refer restoration necessary to complete the Work as shown on the Drawings and Standard Drawing S-1841, Standard Drawing Drain Trough for Conventional Abutments, S-1410, S-1842, Standard Drain Trough for Grade Separation Bridges with Integral Abutments, and S-1843, Standard Drain Trough Terminal Protection" included for Water Crossing Bridges with these Specifications Integral Abutments.~~

## 9.2 Materials

~~All materials shall be supplied. The slopes receiving the concrete drain troughs shall be excavated, trimmed and backfilled to the lines and grades shown on the Drawings or as determined by the Consultant. The subgrade shall be placed and compacted in accordance with Section 2, Backfill.~~

~~A minimum of one week prior to commencing the Work, the Contractor. The bags shall be approximately 400 x 700 mm in size. The submit a detailed layout and forming plan to the Consultant for review and acceptance.~~

## 9.2 Concrete

~~Concrete shall be as specified under Class C concrete and meet all requirements of Section 4— "Cast-In-Place Concrete".~~

## 9.3 Preparation and Placing

~~A depression shall be formed at the toe of the drain trough as shown on Standard Drawing S-1410. The depression shall be compacted, and have the shape of a dish approximately 450 mm deep and 3 m in diameter.~~

~~The bags shall be two-thirds filled with fresh concrete. Bags shall be sewed, stapled or folded to form a straight-edge closure, and immediately placed in the work. The first bag shall be placed in the centre (bottom) of the dish with subsequent bags placed in a circular direction around the first bag. Each bag shall overlap the closed end of the bag previously placed, and also the bag beside it, so that a shingled effect is produced.~~

~~Folded bags must be handled so as to avoid spillage, and the folded part is to be on the underside when in place. The bags shall be rammed and packed against each other so as to obtain a closed and uniform surface. The placed drain trough terminal protection shall have an average thickness of 130 mm.~~

~~The outer edge of the concrete-filled burlap bags of the completed drain trough terminal shall be level.~~

**9.3 9.4 — Reinforcing Steel**

Reinforcing steel shall be plain reinforcing and meet all requirements of Section 5, Reinforcing Steel.

**9.4 Heavy Rock Riprap Alternate**

Heavy Rock Riprap shall be Class 1M or Class 1 and meet all requirements of Section 10, Heavy Rock Riprap.

In lieu of bags filled with concrete, the Consultant may approve Class 1M rock riprap placed to a minimum depth of 350 mm. The size of the terminal dish shall be the same as for bagged concrete terminal protection with the bed shaped to the extent that the dimension from the level surface to the top of rock riprap is  $320 \pm 100$  mm.

**9.5 ~~The dish formed in the subgrade shall be covered with Terrafix 270R or approved equivalent~~ Geotextile Filter Fabric**

Geotextile filter fabric. The shall be non-woven geotextile filter fabric shall be keyed 300 mm into the subgrade at the perimeter of the dish in order to anchor the fabric. The and meet all requirements of Section 10, Heavy Rock Riprap.

The heavy rock riprap shall be placed so that the filter fabric is fully covered.

**9.6 9.5 — Site Restoration**

Upon completion of the drain trough, the Contractor shall restore the site to the original condition and as determined by the Consultant. This shall include disposing of all surplus excavated materials, backfilling as required, supplying and placement of 50 mm minimum thickness of organic material on all disturbed areas and seeding.

**Measurement and Payment****9.7 The construction**

Measurement for payment of drain troughs will be by the metre of drain trough acceptably constructed, measured to the nearest 0.1 m.

The quantity to be paid for will be measured as the total length from the roadway edge adjacent to the drain trough collector to the end of terminal protection, including.

Payment will be made at the unit price bid for "Drain Troughs", and will be full compensation for preparation of the slopes; the supply of and placement of reinforcing steel, concrete, geotextile filter fabric and heavy rock riprap; construction of concrete drain trough collectors and terminal protection; site restoration; and all required labour, materials, will be equipment, tools and incidentals necessary to complete the Work as shown on the Drawings and to the satisfaction of the Consultant.



All costs associated with concreting in cold weather, when required, will be considered incidental to the ~~Contract~~Work, and no separate or additional payment will be made.



STANDARD SPECIFICATIONS FOR BRIDGE CONSTRUCTION

SECTION 10 HEAVY ROCK RIPRAP

TABLE OF CONTENTS

<b>10.1</b>	<b>General.....</b>	<b>10-1</b>
<b>10.2</b>	<b>Permits.....</b>	<b>10-1</b>
<b>10.3</b>	<b>Heavy Rock Riprap Material .....</b>	<b>10-1</b>
<b>10.4</b>	<b>Non-Woven Geotextile Filter Fabric .....</b>	<b>10-4</b>
<b>10.5</b>	<b>Placing of Heavy Rock Riprap.....</b>	<b>10-5</b>
<b>10.6</b>	<b>Inspection of Heavy Rock Riprap.....</b>	<b>10-5</b>
<b>10.7</b>	<b>Measurement and Payment.....</b>	<b>10-6</b>



## 10.1 General

This specification is for the supply, delivery, and installation of heavy rock riprap. This work shall include all necessary trimming, excavation, and ~~fill~~backfill required to satisfactorily place the heavy rock riprap, such as:

- ~~Excavation, trimming and shaping headslope;~~
- ~~Excavation at headslope toe, and for rock apron;~~
- ~~Excavation for heavy rock riprap in stream bank transition zone;~~
- ~~Supply and placing of non-woven geotextile filter fabric;~~
- ~~Supply and placing of gravel or granular bedding material; and~~
- ~~Backfill over heavy rock riprap in stream bank transition zone to restore lines of natural bank.~~

## 10.2 ~~10.2~~ Permits

The Contractor shall obtain whatever permits, agreements, and authorizations are necessary, prior to loading the heavy rock riprap. ~~He~~The Contractor shall advise the Consultant of any special provisions required under such permits, and must provide evidence satisfactory to the Consultant that the requirements of the permits have been fully complied with before final payment will be made.

## 10.3 ~~10.3~~ Heavy Rock Riprap Material

The heavy rock riprap supplied shall be hard, durable and angular in shape, resistant to weathering and water action, free from overburden, spoil, shale or shale seams and organic material, and shall meet the gradation requirements for the class specified. In general, no sandstone will be permitted for all classes, however if the proposed material meets or exceeds the minimum requirements, consideration may be given to accepting the material. For these occurrences, further testing shall be done to ensure acceptability. This would include testing of the material in accordance with CSA A23.2-15A "Petrographic Examination of Aggregates". The minimum dimension of any single rock shall be not less than one third of its maximum dimension. The minimum acceptable unit weight of the rock is 2.5 t/m<sup>3</sup>.

The Contractor shall provide the Consultant with evidence of the acceptability of the heavy rock riprap material. Reliable performance records of proposed material, other than fieldstone, will be considered evidence of acceptability. Angular fieldstone shall be considered to have a reliable performance record, and will be accepted if it meets the gradation requirements.

Sampling and testing are required for Class 2 and ~~Class 3~~ heavy rock riprap for which no performance records are available. Sampling and testing are not required for Class 1 heavy rock riprap and field stone. Tests are based on the Durability Index and Durability Absorption Ratio as developed by the State of California, Department of Transportation. The Contractor shall submit samples of the proposed material to an independent certified testing laboratory of his choice and provide written reports of the test results to the Consultant. The reports shall be stamped by a Professional Engineer, registered in the Province of Alberta. The Contractor shall be responsible for all associated costs for heavy rock riprap sample testing including, but not limited to, transporting samples to an independent certified testing laboratory, testing, disposing of samples after testing, and providing written reports to the Consultant.

A representative sample of 70 kg minimum is required for each type and source of rock to be tested, and shall contain a number of pieces ranging up to 25 kg mass. The acceptance of rock samples from a particular source or quarry site shall not necessarily be construed as constituting acceptance of all material from that location.

The material provided ~~for each class specified~~ shall ~~have a gradation that conforms to meet~~ the ~~following requirements of Tables 10-1, Gradation Requirements and Table 10-2, Specific Gravity, Absorption and Durability Index Requirements.~~

**Table 10-1: Gradation Requirements <sup>(1)</sup>**

<u>Gradation</u>		<u>Heavy Rock Riprap Class</u>	<u>CLASS</u>		
<u>Required Properties</u>	<u>Units</u>	<u>1M</u>	<u>1</u>	<u>2</u>	<u>3</u>
Nominal Mass (kg)		7	40	200	700
Nominal Diameter (mm)	kg	<del>175</del>	<del>300</del>	<del>500</del>	<del>800</del>
	mm	<del>175</del>	<del>300</del>	<del>500</del>	<del>800</del>
None greater than:	kg	40	130	700	1800
	or mm	<del>300</del>	<del>450</del>	<del>800</del>	<del>1100</del>
	mm	<del>300</del>	<del>450</del>	<del>800</del>	<del>1100</del>
20% to 50%	kg	10	70	300	1100
	or mm	<del>200</del>	<del>350</del>	<del>600</del>	<del>900</del>
	mm	<del>1200</del>	<del>350</del>	<del>600</del>	<del>900</del>
50% to 80%	kg	7	40	200	700
	or mm	<del>175</del>	<del>300</del>	<del>500</del>	<del>800</del>

	<u>mm</u>	<u>175</u>	<u>300</u>	<u>500</u>	<u>800</u>
100% greater than:	kg	3	10	40	200
	<del>or mm</del>	<del>125</del>	<del>200</del>	<del>300</del>	<del>500</del>
	<u>mm</u>	<u>125</u>	<u>200</u>	<u>300</u>	<u>500</u>

Notes:

(1) Percentages quoted are by mass. Sizes quoted are equivalent spherical diameters, and are for guidance only.

~~Riprap shall meet the following minimum requirements for Table 10-2:~~ Specific Gravity, Absorption and Durability:

Method of test ————— Index Requirements <sup>(1)</sup>

~~California Department of Transportation ————— Minimum Specific Gravity = 2.60~~

~~Method of Test for Specific Gravity and~~ ———

~~Absorption of Coarse Aggregate ————— Maximum Absorption = 2.0 %~~

~~(California Test 206)~~

~~California Department of Transportation ————— Minimum Durability Index = 52~~

~~Method of Test for Durability Index —~~

<u>Test Method</u>	<u>Requirement</u>
<u>California Department of Transportation Method of Test for Specific Gravity and Absorption of Coarse Aggregates (California Test 206)</u>	<u>Minimum Specific Gravity = 2.60</u> <u>Maximum Absorption = 2.0 %</u>
<u>California Department of Transportation Method of Test for Durability Index (California Test 229)</u>	<u>Minimum Durability Index = 52</u> <sup>(1)</sup>

Notes:

~~Durability Index may be less than 52 (California Test 229)~~ if the durability absorption ratio (DAR\* ->) is greater than 23

(1) ~~\*Durability Absorption Ratio~~ (where DAR) = Durability Index / (Absorption % +1%)

**10.4 10.4—Non-Woven Geotextile Filter Fabric**

Where non-woven geotextile filter fabric is specified, the slope shall be graded to provide a smooth, uniform surface. All stumps, large rock, brush or other debris that could damage the fabric shall be removed. All holes and depressions shall be filled so that the fabric does not bridge them. Loose or unstable soils shall be replaced.

Non-woven geotextile filter fabric shall be used under all riprap ~~in accordance with and shall meet the following table of~~ minimum average roll value properties (MARV's) ~~for each specific Class of riprap listed in Table 10-3, Non-Woven Geotextile Filter Fabric Requirements.~~

**Table 10-3: Non-Woven Geotextile Filter Fabric Requirements**

<b><u>Non-Woven Geotextile Filter Fabric</u></b>		
<b><u>Specifications and Required Physical Properties</u></b>	<b><u>Test Method</u></b>	<b><u>Minimum MARV Required</u></b>
	<del>Class 1M, 1 and 2</del>	<b>Class <u>1M, 1, 2, and 3</u></b>
Grab Strength <del>(ASTM D4632)</del>	<del>ASTM D4632</del> 650 N	875 <u>900</u> N
Elongation (Failure) <del>(ASTM D4632)</del>	<del>ASTM D4632</del> 50%	50%
CBR Puncture Strength <del>(ASTM D6241)</del>	<del>ASTM D6241</del> 275 N	550 N
Trapezoidal Tear <del>(ASTM D4533)</del>	<del>ASTM D4533</del> 250 N	350 N
<b><u>Minimum Fabric Lap to be 300 mm</u></b>		

The non-woven geotextile filter ~~fabric shall meet the specifications and physical properties as listed above.~~

~~The~~ fabric shall be laid parallel to the slope direction. It shall be placed in a loose fashion, however, folds and wrinkles shall be avoided. ~~Adjacent strips of~~ The minimum non-woven geotextile filter fabric lap shall be ~~overlapped a minimum of 300-400~~ mm, except where placed underwater, the minimum lap width shall be 1 m. Overlaps shall be pinned using 6 mm diameter steel pins fitted with washers and spaced at 1 m intervals along the overlaps.

The top edge of the non-woven geotextile filter fabric shall be anchored by digging a 300 mm deep trench, inserting the top edge of the non-woven geotextile filter fabric and backfilling with compacted soil.

Care shall be taken to prevent puncturing or tearing the non-woven geotextile filter fabric. Any damage shall be repaired by use of patches that extend at least 1 m beyond the perimeter of the tear or puncture.



The non-woven geotextile filter fabric shall be covered by heavy rock riprap within sufficient time so that ultraviolet damage does not occur; in no case shall this time exceed 7 days for ultraviolet material and 14 days for ultraviolet protected and low ultraviolet susceptible polymer ~~geotextiles~~non-woven geotextile filter fabric.

Heavy rock riprap placement shall commence at the base of the blanket area and proceed up the slope. The height of drop of riprap shall be limited to 1.0 m or less, and the heavy rock riprap shall not be allowed to roll down the slope. Heavy equipment will not be permitted to operate directly on the geotextile.

**10.5 10.5—Placing of Heavy Rock Riprap**

The heavy rock riprap shall be handled, dumped or placed into position to conform to the specified gradation and to the cross section shown on the Drawings. The finished surface shall be reasonably uniform, free from bumps or depressions, and with no excessively large cavities below or individual stones projecting above the general surface.

**10.6 10.6—Inspection of Heavy Rock Riprap**

Control of gradation will be by visual inspection. The Contractor shall provide a minimum of two samples of heavy rock riprap, of the minimum sample size specified below. These samples shall be proven to acceptably conform to the required gradation by direct weighing of all the individual pieces with suitable scales; the mass of each piece in the sample shall be painted on the piece. These samples, located as required by the Consultant at the construction site and at the source or quarry site, may be incorporated in the finished riprap when they are no longer required for reference purposes. The samples shall be used for frequent reference in judging the gradation of the heavy rock riprap being loaded at the source and placed at the site. The minimum sample size in area shall ~~be as follows:~~meet the requirements of Table 10-4, Heavy Rock Riprap Inspection Sample Size Requirement.

**Class Minimum Table 10-4: Heavy Rock Riprap Inspection Sample Size Requirements**

1M	1 m x 1 m
1	2 m x 2 m
2	3 m x 3 m
3	4 m x 4 m

<u>Heavy Rock Riprap Class</u>	<u>Inspection Sample Size</u>
<u>1M</u>	<u>1 m x 1 m</u>
<u>1</u>	<u>2 m x 2 m</u>
<u>2</u>	<u>3 m x 3 m</u>
<u>3</u>	<u>4 m x 4 m</u>

The Contractor shall provide, at no additional cost to the Department, whatever facilities are required to assist the Consultant in checking gradation and measuring heavy rock riprap in place.

If, during the delivery of the material to the site, a particular load is found to be made up of pieces predominantly one size, or to be lacking in pieces of one size, it shall be dumped in a suitable location outside the area to be protected. Additional material as required to make up the deficient sizes shall be added to this load such that the combination can then be placed to ensure uniformity.

#### **10.7—Measurement and Payment**

##### **10.7 The quantity**

Measurement for payment of heavy rock riprap will be by the cubic metre of heavy rock riprap acceptably placed, measured to the nearest 0.1 m<sup>3</sup>.

The quantity to be paid for will be measured in place. The volume of rock paid for will be calculated from the based on the thickness of the heavy rock riprap as shown specified on the Drawings, and multiplied by the actual area covered. Overages in thickness or area beyond the measured surface area of ground covered with heavy rock riprap as determined by the Consultant and the Department. Heavy rock riprap placed outside of the plan limits shown on the Drawings will not be paid for unless placement in these changes were requested additional areas has been reviewed and accepted by the Consultant and Department prior to the Work.

Payment will be made at the unit price bid per cubic metre of for “Heavy Rock Riprap acceptably in place, which price shall include”, of the class specified, and will be full compensation for all necessary materials, royalties, permits, haul of materials, sampling and testing, transportation, the preparation, weighing and inspection of sample sizes, excavation and subgrade preparation, including backfilling; the supply and placement of non-woven geotextile fabric; the supply and placement of heavy rock riprap; and all labour, equipment, tools, labour and incidentals necessary to complete the Work, including the preparation of the subgrade for the riprap, geotextile filter fabric, bedding material, trimming, excavation, backfill as required, and labour for measurement, as shown on the Drawings and to the satisfaction of the Consultant.

STANDARD SPECIFICATIONS FOR BRIDGE CONSTRUCTION

**SECTION 11 DUCTS AND ~~VOIDS~~CONDUITS**

TABLE OF CONTENTS

<b>11.1 General.....</b>	<b>11-1</b>
<b>11.2 Material.....</b>	<b>11-1</b>
<b>11.3 Installation.....</b>	<b>11-1</b>
<b>11.4 Payment.....</b>	<b>11-2</b>



## 11.1 General

This specification is for the supply and installation of all ducts, and conduits ~~or voids as set out in the drawings and these specifications. Included are the following:~~

~~— utility ducts and voids~~  
~~— rigid conduits, end caps, conduit expansion joints, , associated hardware,~~ junction boxes ~~lamp standard, and~~ anchorage assemblies as shown on the Drawings.

## 11.2 ~~11.2~~ Material

All ~~utility ducts and voids, fittings and accompanying hardware, to be incorporated in or erected on the structure,~~ ducts and conduits shall be rigid PVC type DB2 meeting the requirements of CSA C22.2 No. 211.1 and in accordance with the Rules of the Canadian Electrical Code, Part 1. Coupling shall be solvent bell ends (SBE). ~~Rigid conduit shall be bent only with a standard conduit bender.~~

Expansion assemblies for PVC shall be Scepter type 'O' tingring expansion joints or an approved equivalent.

~~11.3~~ Rigid conduit shall be as specified on the Drawings.

## 11.3 Installation

~~The various components~~ Ducts and conduits shall be ~~erected or placed in the locations~~ installed as shown on the Drawings.

~~Ducts, conduits and voids shall be~~ and firmly secured to prevent ~~floating during casting~~ displacement.

Continuous pull wires shall be installed in all ~~service~~ ducts and conduits unless specified otherwise. The pull wires shall be 12 gauge galvanized steel, unspliced, extending with a tight fit through the duct end caps and terminating one metre beyond in 300 mm loops. In lieu of the galvanized pull wire, an 8 mm mono ~~-poly~~ rope or equivalent may be substituted in ducts over 75 mm diameter. ~~In this case,~~ The rope shall be unspliced, with the extra length of 300 mm each end coiled up inside the duct and the duct end caps secured in place.

~~When specified, lamp standards shall be properly bedded, securely bolted, and painted with two field coats.~~

The installation of ~~any electrical~~ equipment components shall be carried out ~~to completion~~ by a fully qualified electrician, ~~tested and left in good working order.~~ All runs of ~~conduit or duct~~ ducts and conduits shall be proven in the presence of the Consultant ~~to be clear~~ by passing through the entire length, a round object no less than 75% of the conduit area. Any required permits will be the responsibility of the Contractor.

**11.4 ~~11.4~~—Payment**

~~Unless **Ducts** is listed in~~All costs associated with the Unit Price Schedules supply and installation of the Tender pages, this work shall be ducts and conduit will be considered incidental to the ~~Contract~~Work, and no separate or additional payment will be made.

# STANDARD SPECIFICATIONS FOR BRIDGE CONSTRUCTION

## SECTION 12 BRIDGERAIL

### TABLE OF CONTENTS

<b>12.1</b>	<b>General</b>	<b>12-1</b>
<b>12.2</b>	<b>Supply and Fabrication</b>	<b>12-1</b>
12.2.1	Standards	12-1
12.2.2	Qualification	12-1
12.2.3	Engineering Data	12-2
12.2.3.1	Welding Procedures	12-2
12.2.3.2	Shop Drawings	12-2
12.2.3.3	Mill Test Reports	12-3
12.2.4	Materials	12-3
12.2.4.1	Steel	12-3
12.2.4.2	Anchor Rods	12-3
12.2.4.3	Connection Plate and Angle	12-4
12.2.4.4	Grout	12-4
12.2.4.5	Approach Rail Transition	12-4
12.2.5	Welding	12-4
12.2.5.1	Filler Metals	12-4
12.2.5.2	Joint Preparation	12-4
12.2.5.3	Tack and Temporary Welds	12-4
12.2.5.4	Backing Bars	12-5
12.2.5.5	Run-off Tabs	12-5
12.2.5.6	Arc Strikes	12-5
12.2.5.7	Methods of Weldment Repair	12-5
12.2.5.8	Grinding of Welds	12-5
12.2.5.9	Preheat and Interpass Temperatures	12-6
12.2.6	Fabrication	12-6
12.2.6.1	Rail Fabrication	12-6
12.2.6.2	Rail Sleeve Fabrication	12-6
12.2.6.3	Post Fabrication	12-6
12.2.6.3.1	W Posts	12-6
12.2.6.3.2	HSS Posts	12-7
12.2.6.4	Anchor Rods	12-7
12.2.6.5	Tolerances	12-7
12.2.6.5.1	Sleeve to Rail	12-7
12.2.6.5.2	Posts	12-8
12.2.6.5.3	Rails	12-8
12.2.6.5.4	Anchor Rods	12-8
12.2.6.6	Identification	12-8
12.2.6.7	Galvanizing	12-8
12.2.6.8	Base Plate Corrosion Protection	12-10
12.2.6.9	Schedule	12-10
12.2.7	Testing and Inspection	12-10
12.2.7.1	Access	12-10
12.2.7.2	Responsibility	12-10

12.2.7.3	Testing by the Contractor.....	12-11
12.2.7.4	Notification to Ship.....	12-11
12.2.8	Material Handling and Storage.....	12-12
12.2.9	Fabrication Outside of Canada.....	12-12
<b>12.3</b>	<b>Erection.....</b>	<b>12-13</b>
12.3.1	Grouting of Base Plates.....	12-13
12.3.1.1	Grouting in Cold Weather.....	12-14
12.3.2	Approach Rail Transition.....	12-15
<b>12.4</b>	<b>Payment.....</b>	<b>12-15</b>



## 12.1 General

This specification is for the supply, fabrication and installation of steel tube type bridgerail, thrie beam bridgerail, approach rail transition, and ~~handrail~~pedestrian/bicycle barriers. Bridgerail and ~~handrail~~pedestrian/bicycle barriers shall include all work constructed above the top of the bridge deck, curb, parapet, sidewalk, or culvert headwalls, and wing walls, and the supply and placing of anchor ~~boltr~~rod assemblies, end connection plates and connection angles. Approach rail transition shall include thrie beam or W-beam guardrail sections, W-thrie beam transition section, terminal connectors, steel or timber guardrail posts, spacers, and guardrail connection and wing end sections where specified.

## 12.2 ~~12.2~~—Supply and Fabrication

A pre-fabrication meeting is required prior to commencement of fabrication of bridgerail. The meeting will be held at fabricator's plant and the contractor shall ensure the plant superintendent and plant manager responsible for the work and any manufacturer's representatives directly involved in the specialized work are in attendance. The ~~DEPARTMENT~~/consultant will conduct this meeting after the shop drawings have been approved and welding procedures and mill test reports have been reviewed. The contractor shall provide ~~ONE WEEK~~a minimum of 2 weeks' notice to the ~~DEPARTMENT~~/Consultant prior to the meeting.

### 12.2.1 ~~12.2.1~~—Standards

The fabrication of bridgerail components shall conform to AASHTO LRFD Bridge Construction Specifications and the American Welding Society (AWS) - Bridge Welding Code D1.5.

~~Where imperial/metric conversions are necessary, the National Standard of Canada, CAN3 - Z234.1 - 79 shall be used as the basis of conversion.~~

All welding, cutting and preparation shall be in accordance with the American Welding Society (AWS) - Bridge Welding Code D1.5. The fabrication of bridgerail components composed of structural tubing shall be in accordance with the American Welding Society (AWS) – Structural Welding Code D1.1.

### 12.2.2 ~~12.2.2~~—Qualification

The Contractor shall notify the Department and Consultant two weeks prior to fabrication of any subcontractors in his employ. The Contractor shall remain responsible for the work of the subcontractors. All terms of the contract, such as CWB approval, right of access, etc., shall apply to the subcontractor.

The fabricator shall be fully approved by the Canadian Welding Bureau (CWB) as per CSA Standard W47.1 in Divisions 1 or 2.

Only welders, welding operators and tackers approved by the Canadian Welding Bureau in the particular category shall be permitted to perform weldments. Their qualifications shall be current and available for examination by the Consultant.

### 12.2.3 ~~12.2.3~~ Engineering Data

#### 12.2.3.1 ~~12.2.3.1~~ Welding Procedures

Welding procedures, including welding procedure datasheets ~~bearing the approval of the Canadian Welding Bureau,~~ shall be submitted for each type of weld ~~to be used~~proposed. The welding procedures shall bear the approval of the CWB and be reviewed and accepted by the Department and Consultant before welding proceeds and the Department a minimum of 3 weeks prior to the commencement of fabrication.

#### 12.2.3.2 ~~12.2.3.2~~ Shop Drawings

Shop drawings shall be submitted to the Consultant for review and acceptance a minimum of 3 weeks in advance of the commencement of fabrication. Review comments provided by the Consultant and/or the Department shall be incorporated into the shop drawings and resubmitted to the Consultant for review and acceptance prior to the commencement of fabrication.

~~Shop drawing requirements shall be as per section 6.2.3.3 of the Specifications for Bridge Construction.~~

Shop drawings shall be electronic unlocked PDF format. Each shop drawing shall include the Department's shop drawing identification block and have a sufficient blank space for the Consultant's review stamp. The Department's shop drawing identification block will be provided to the Contractor upon request. As a minimum, the following information shall be included on shop drawing submissions:

- All dimensions shall be correct at 20 °C unless otherwise noted;
- Weld procedure identification shall be shown on the shop drawings in the tail of the weld symbols;
- All material splice locations shall be shown on the drawings;
- Sizes of hardware and any other material shown on the shop drawings shall be in the actual units (imperial or metric) of the material being supplied.

When ~~railing~~bridgerail for more than one bridge is included in the Contract, individual shop ~~and erection~~ drawings shall be submitted for each bridge. ~~Shop drawing mark numbers must be unique for each bridge structure.~~

#### 12.2.3.3 ~~12.2.3.3~~ Mill Certificates

~~Mill certificates~~The shop drawings will be reviewed by the Consultant solely to ascertain general conformance with codes and specifications. The Consultant's review and acceptance shall not be considered as relieving the Contractor of the responsibility for completing the Work in accordance with the Contract requirements.

The Contractor shall incorporate as-built construction conditions into shop drawings. One paper copy and one electronic copy (PDF format) of as-built shop drawings shall be submitted to the Consultant within 3 weeks of construction completion.

### 12.2.3.3 Mill Test Reports

Mill test reports shall be provided for all ~~material before fabrication commences~~ materials in English.

Mill test reports shall be submitted to the Consultant for review and acceptance 3 weeks prior to the commencement of fabrication.

Where mill test ~~certificates~~ reports originate from a mill outside Canada or the United States of America, the Contractor shall have ~~the material tested and the~~ mill test ~~certificate~~ reports verified by a Canadian certified laboratory. ~~This in Canada by testing the material to the specified material standards, including boron content. The testing~~ laboratory shall be certified to ISO/IEC 17025 by an organization accredited by the Standards Council of Canada ~~to comply with the requirements of ISO/IEC 17025 for the specific tests or type of~~ for the tests required by the material standard specified on the mill test certificate. ~~The mill test certificates shall be stamped with the name of the Canadian laboratory and the signature of.~~ Samples for testing shall be collected by personnel employed by the certified laboratory. A verification letter shall be provided by the certified laboratory that includes at a minimum, the applicable mill test reports, testing standards, date of verification testing, and declaration of material compliance with Contract requirements. The verification letter shall be signed by an authorized officer. ~~It shall state that the material is in conformance with the specified Contract requirements of the certified laboratory.~~

### 12.2.4 ~~12.2.4~~ — Materials

#### 12.2.4.1 ~~12.2.4.1~~ — Steel

All steel shall conform to the standard noted on the Drawings.

Steel with a boron content exceeding 0.0008% will not be permitted.

The silicon content for various bridgerail and ~~handrail~~ pedestrian/cyclist barrier components shall be as follows:

- Structural tubing less than 0.04%~~%~~; and
- Structural sections, handrail bars, base plates less than 0.04% or between 0.15% ~~to~~ and 0.25%~~%~~.

~~If substitutions are required they must be accepted by the Department and Consultant. In these cases interpretation of equivalent steel will be as per Appendix "A" of the CSA Standard G40.21 (1976 only).~~

#### 12.2.4.2 — Anchor Bolts

#### 12.2.4.2 Anchor bolts Rods

Anchor rods shall conform to the standard noted on the Drawings. The Contractor shall provide mill test reports indicating the physical properties of the material to the Consultant.

~~12.2.4.2~~ ~~12.2.4.3~~ ~~12.2.4.3~~ Connection Plate and Angle

Steel for connection plate and angle shall conform to CSA Standard G40.21 ~~21M~~ Grade 300W or ASTM A36.

~~12.2.4.3~~ ~~12.2.4.4~~ ~~12.2.4.4~~ Grout

Grout for post bases shall be ~~Sika 212 flowable grout or approved equivalent~~ selected from the Alberta Transportation Product List, Non-Shrink Grout category.

~~12.2.4.4~~ ~~12.2.4.5~~ ~~12.2.4.5~~ Approach Rail Transition

Three beam or W-beam guardrail sections, W-three beam transition section, terminal connectors, steel or timber guardrail posts, spacers, and guardrail connection and wing end sections shall be ~~as specified~~ in accordance with Section 14-“Guardrail”.

12.2.5 ~~12.2.5~~ Welding12.2.5.1 ~~12.2.5.1~~ Filler Metals

Low hydrogen fillers, fluxes and welding practices shall be used throughout. The low hydrogen covering and flux shall be protected and stored as specified by AWS Standard D1.5. Flux cored welding or use of cored filled wires in the submerged arc process or shielding gas processes will not be permitted.

~~Metal core welding process utilizing low~~ All electrodes and fluxes shall conform to the diffusible hydrogen consumables with requirements of AWS designation of D1.5 filler metal hydrogen designator H4 is allowed. The for the Shielded Metal Arc Welding (SMAW) and Metal Core Arc Welding (MCAW) processes. Deposited weld metal shall provide strength, durability, impact toughness, and corrosion resistance equivalent to base metal.

Field application of metal core arc welding is not allowed.

12.2.5.2 ~~12.2.5.2~~ Joint Preparation

Preparation of welded joints shall be as indicated on the Drawings. Weld areas shall be clean, free of mill scale, dirt, grease, paint and other contaminants prior to welding.

12.2.5.3 ~~12.2.5.3~~ Tack and Temporary Welds

Tack and temporary welds shall not be allowed unless they are to be incorporated into the final weld. Tack welds, where allowed, shall be of a minimum length of four times the nominal size of the weld, and shall be subject to the same quality requirements as the final welds. Cracked tack welds shall be completely removed prior to welding over.

#### 12.2.5.4 ~~12.2.5.4~~—Backing Bars

Backing bars shall be fitted all around the inside of the joint. The separation of faying surfaces between the backing bars and material to be welded shall not exceed 1 mm, 100% fusion must be obtained into the backing bar including the corners of HSS members.

#### 12.2.5.5 ~~12.2.5.5~~—Run-off Tabs

Run-off tabs shall be used at the ends of all welds that terminate at the edge of a member. The thickness and shape of the tabs shall replicate the joint detail being welded and shall be a minimum of 100 mm long unless greater length is required for satisfactory work. They shall be tack welded only to ~~the~~that portion of the material that will not remain a part of the structure, or where the tack will be welded over and fused into the final joint. After welding, the tabs ~~shall~~are to be removed by flame cutting, not by breaking off.

#### 12.2.5.6 ~~12.2.5.6~~—Arc Strikes

~~Arc strikes are not permitted.~~

~~12.2.5.7 —Arc strikes will not be permitted. If accidental arc strikes occur, a detailed repair procedure shall be submitted to the Department and Consultant for review and acceptance prior to the commencement of repair work. The repair procedure shall include the complete grinding out of the crater produced by the arc strike prior to repair. The Contractor shall complete magnetic particle inspection (MPI), and hardness testing of the repaired area. Hardness of the repaired area shall meet the requirements of Subsection 6.2.8.11, Hardness Tests. The repair procedure shall be signed and sealed by experienced welding Professional Engineer registered in the Province of Alberta.~~

~~All arc strike repairs shall be repaired to the full satisfaction of the Consultant and the Department.~~

#### 12.2.5.7 Methods of Weldment Repair

~~The Contractor shall submit~~ repair procedures for damaged base metal and unsatisfactory weldments ~~shall be submitted for review and acceptance, prepared and stamped by an experienced welding engineer registered as a Professional Engineer in the Province of Alberta for review~~ by the Department and Consultant prior to repair work commencing.

#### 12.2.5.8 ~~12.2.5.8~~—Grinding of Welds

~~Post to base plate groove welds which are sufficiently smooth with a neat appearance and uniform profile as determined by the Consultant will not require grinding. Groove welds in rail splices shall be ground smooth and flush.~~

Fillet welds not conforming to an acceptable profile shall be ground to the proper profile without damaging of substantial removal of the base metal.

Grinding shall be smooth and parallel to the line of stress. Caution shall be exercised to prevent over grinding. Over grinding that results in reduced thickness of the base metal or size of the weld shall not be permitted. Acceptability of the welds without grinding will be determined by the Consultant.

#### 12.2.5.9 12.2.6—Preheat and Interpass Temperatures

Preheat and interpass temperature requirements shall be performed and maintained as per AWS D1.5, except that all post to base plate groove welds and post to base plate fillet welds shall be preheated to a minimum temperature of 100 °C and 60 °C respectively unless a higher temperature is required by AWS D1.5.

#### 12.2.6 Fabrication

Fabrication shall be performed in a fully enclosed ~~area~~permanent structure which is adequately heated to be at least 10 °C.

##### 12.2.6.1 ~~12.2.6.1~~—Rail Fabrication

~~All rail splices will be radiographed.~~The Contractor shall radiograph all rail splices. A copy of the test results shall be provided to the Consultant within 1 week of testing completion. Splices shall be completed using properly fitted backing bars. Only one splice per rail section ~~will~~shall be permitted, and shall occur in an accepted location, clear of openings and connection holes. All splices shall be ground flush. Rail sections shall be orientated such that the tube seam is always located at the bottom, except for rectangular tube sections which shall have the tube seam oriented towards the bottom or the outside of the bridge. Edges of holes shall be smooth and free of notches or burrs.

##### 12.2.6.2 ~~12.2.6.2~~—Rail Sleeve Fabrication

Sleeves shall be square and be properly aligned in the rail end. Corners of the sleeves shall be rounded and smooth to ensure a good fit. Expansion joint sleeves shall be shop bolted to the appropriate rail section after galvanizing.

##### 12.2.6.3 ~~12.2.6.3~~—Post Fabrication

###### 12.2.6.3.1 ~~(a)~~—W Posts

Posts shall be perpendicular to the base plates, unless otherwise noted on the drawings.

Base plates for the posts shall be flat, have square cut edges and corners with no lips or gouges. Anchor ~~bolt~~rod holes shall be drilled accurately in size and location.

~~The rail Contractor shall complete magnetic particle inspection on 25% of all post to base plate fillet welds. A copy of the test results shall be welded by using 60°C preheat provided to the Consultant within 1 week of testing completion.~~

12.2.6.3.2 ~~(b)~~—HSS Posts

~~The following requirements shall apply to HSS posts, in addition to and baseplates shall meet the requirements of Subsection 12.2.6.3.1, W Posts except as noted under W Posts in this subsection.~~

The tube weld seam shall be kept on the back side of the post.

~~The rail post~~Bridgerail posts shall be butt welded to the base plate using a backing bar and a full penetration bevel groove weld. The backing bar shall be properly fitted and the post ~~tube~~ prepared to a sharp edged 45-~~degree~~<sup>°</sup> chamfer. The groove weld shall be placed in a minimum of two passes ~~by using 100°C of preheat and maintain with~~ a root opening of 5 mm. A rod size, no greater than 4.0 mm, shall be used for the first pass. A reinforcing fillet weld shall be placed all around the joint.

The Contractor shall arrange to have all post to base plate full penetration welds inspected either by ultrasonic testing or radiographic inspection methods. ~~The NDTA copy of the test results shall be done by a company certified provided to CAN/GSA W178.1. Ultrasonic and radiographic~~the Consultant within one week of testing technicians completion.

Pedestrian/Cyclist barrier posts shall be certified fillet welded to Level II of CGSB baseplates. The Contractor shall complete magnetic particle inspection on 25% of all post to base plate fillet welds. A copy of the test results shall be provided to the Consultant— within 1 week of testing completion.

Post caps shall be chamfered all around the top and match the contour of the post without burrs or overhang. The caps shall be attached to the posts in the shop after galvanizing. The caps shall fit tightly and include washers under the head of the cap attachment bolts.

12.2.6.4 ~~12.2.6.4~~—Anchor ~~Bolts~~Rods

The threaded ends of all anchor ~~bolts~~rods shall be chamfered. All anchor ~~bolts~~rods, hardware and anchor ~~bolt~~templaterod templates shall be hot dip galvanized, after fabrication in accordance with ASTM F2329 Standard Specification for Zinc Coating Hot-Dip Requirements for Application to Carbon and Alloy Steel Bolts, Screws, Washers, Nuts, and Special Threaded Fasteners. Galvanizing of high strength anchor rod material requires a special process. For details, see Subsection 12.2.6.7, Galvanizing. Nuts shall freely spin on the ~~bolt~~rod threads after galvanizing. The anchor ~~bolts~~rods shall be shop assembled in cages after galvanizing with bolts aligned square and plumb. Alignment nuts shall not exceed 16 mm in thickness.

12.2.6.5 ~~12.2.6.5~~—Tolerances12.2.6.5.1 ~~(a)~~—Sleeve to Rail

Clearance between the rail sections and the sleeves shall be sufficient to ensure an easy fit after galvanizing. The maximum radial clearance allowed around the sleeve when fitted into the rail shall be 1 mm (2 mm total) after galvanizing with the tube seam removed.

Two sleeve test samples shall be made by the fabricator from the material to be used. Both test sleeves are to be galvanized, with one being retained by the galvanizing subcontractor and the other at the fabricator's plant. The sleeves shall be used to check the sleeve to rail fit of all rails. In the case of ~~handrail~~pedestrian/cyclist barrier panels, the test samples shall consist of a welded unit with top and bottom tube, and sleeve sections spaced to match the ~~handrail~~pedestrian/cyclist barrier.

#### 12.2.6.5.2 ~~(b)~~—Posts

Post assembly lengths shall be within 3 mm of the specified length.

#### 12.2.6.5.3 ~~(c)~~—Rails

Individual rail sections shall be straight and true with no evidence of kinks or dents and with a maximum variation from straightness not exceeding 3 mm over a 3 m length. Welded splices shall not be evident in the final product, and shall be straight, kink free and conform to the same section as the adjacent tubing. Bolted splices shall be straight with no offset due to loose fitting sleeves.

#### 12.2.6.5.4 ~~(d)~~—Anchor ~~Bolts~~Rods

The ~~bolts~~rods in an anchor ~~bolt~~rod assembly shall fit in a template comprised of accurately located holes 2 mm greater in diameter than the anchor ~~bolts~~rods. The top of the ~~bolts~~rods in the assembly shall be  $\pm 3$  mm from a level plane when the threaded portion is plumb. The threaded length shall not be less than specified, nor more than 15 mm greater than that specified.

#### 12.2.6.6 ~~12.2.6.6~~—Identification

To assist field erection, shop drawing mark numbers shall be stamped on the rails and posts. Rail mark numbers shall be stamped on the underside of the rail near the ends. Post mark numbers shall be stamped on the underside of the base plates. The areas to be stamped shall be ground to remove mill scale. Stamps shall be a minimum of 12 mm high, and the resulting marks shall be at least 1.0 mm deep to be legible after galvanizing.

#### 12.2.6.7 ~~12.2.6.7~~—Galvanizing

The fabricator shall provide a smooth finish on all edges and surfaces, and remove all weld spatters, and all welding flux residue from the steel components prior to galvanizing.

Factors contributing to galvanization-induced cracking shall be minimized. Galvanizing shall be by the hot dip method, after fabrication, in accordance with the current edition of ASTM A123/A123M Standard Specification for Zinc (Hot-Dip Galvanized) Coatings on Iron and Steel Products and ASTM F2329 Standard Specification for Zinc Coating Hot-Dip Requirements for Application to Carbon and Alloy Steel Bolts, Screws, Washers, Nuts, and Special Threaded Fasteners ~~with additions~~ and ~~exceptions~~ as ~~described~~modified in this specification.



The ~~fabricator~~ cleaning and pickling procedure of high strength ASTM A193 Grade B7 anchor rods shall provide a smooth finish on all edges and surfaces and be modified as follows prior to hot-dip galvanizing:

- Brush blast to remove all weld spatters, mill scale and oil after threading ends;
- Flash pickle up to 5 minutes; and all welding
- Quick dry prior to hot-dip galvanizing (not stored in flux residue from the steel components prior to galvanizing, or acid rinse).

The ~~galvanized finish shall meet modified anchor rod cleaning and pickling procedure shall be completed in the presence of the aesthetic requirements of the application and shall have a continuous outer free zinc layer without any significant zinc-iron alloy showing through the outside surface.~~ Consultant prior to hot-dip galvanizing.

Lumps, globules or heavy deposits of zinc will not be permitted. All threaded holes or threaded couplings shall be retapped after galvanizing.

Handrails shall be free of any sharp protrusions or edges as determined by the Consultant.

~~Double dip galvanizing is not advised but will be accepted if a surface finish similar in appearance, colour and quality to that of single dip galvanizing is produced. The lapped area of the double dip shall be straight, the coating smooth, adherent and free of uncoated areas, blisters, flux deposits, dross inclusions, acid and black spots.~~

Repair of galvanizing shall be completed in accordance ASTM A780, Method A3 "Metallizing" and will only be done if bare permitted when the repair areas are small and infrequent, small, and suitable for repair. A detailed repair procedure shall be submitted for review and acceptance prior to its use. It should be noted that repairs as determined by the Consultant. Repair areas less than 100 mm<sup>2</sup> in area may require complete removal of the galvanized coating and re-galvanizing. Repair shall be completed in compliance accordance with ASTM A780, Method A3 "Metallizing". However repair for areas not exceeding 100 mm<sup>2</sup> may be done in accordance with ASTM Method A1 "Repair Using Zinc-Based Alloy". The thickness of the coating for both methods shall be 180 µm, and the repair tested for adhesion. A detailed repair procedure shall be submitted for review and acceptance by the Consultant prior to commencement of the work. Repairs may require complete removal of the galvanized coating and re-galvanizing. The finished appearance shall be similar to the adjacent galvanizing. as determined by the Consultant will determine the acceptability of lapped or repaired areas.

12.2.6.8 Galvanized material shall be stacked or bundled and stored to prevent wet storage stain as per the American Hot Dip Galvanizers Association (AHDGA) publication "Wet Storage Stain". Any evidence of wet storage stain shall be removed to the satisfaction of the Consultant.

#### 12.2.6.8 Base Plate Corrosion Protection

The bottom surface of each base plate shall be protected by a medium grey colour barrier coating accepted by the Consultant, to prevent contact between the zinc and the concrete. The galvanized surface must be roughened prior to application of barrier coating. The surface preparation of the galvanized surface and the dry film thickness (DFT) of the coating shall be in accordance with the coating Manufacturer's recommendations.

The Consultant will test the adhesion of fully cured coating as per ASTM D3359 "Standard Test Methods for Measuring Adhesion by Tape Test". The method selected for testing (Method A or B) shall depend on the dry film thickness of the coating. The coating manufacturer's product data sheets shall be provided to the Consultant prior to the application of the coating. The adhesion test result shall meet a minimum of "4B" classification i.e. a maximum allowable flaking of 5%.

#### 12.2.6.9 ~~12.2.6.9~~ Schedule

The Contractor shall provide and keep current a complete fabrication schedule in a form satisfactory to the Consultant.

#### 12.2.7 ~~12.2.7~~ Testing and Inspection

##### ~~12.2.7.1 Testing by the Consultant~~

~~Visual, radiographic, ultrasonic, magnetic particle and any other inspection that may be specified or required will be performed by the Consultant or his testing agencies at the Consultant's expense.~~

##### 12.2.7.1 Access

The Contractor shall ~~ensure that adequate notice~~provide full facilities for the inspection ~~and testing be given to of Work.~~ The Consultant ~~and that~~shall have full access to all parts of the Work ~~is assured~~ at all times. When required by the Consultant, the Contractor shall provide needed manpower for assistance in checking layout and performing inspection duties.

##### 12.2.7.2 Responsibility

It is the Contractor's responsibility to ensure that the Work is completed in accordance with the Contract requirements. Any inspection and/or testing completed by the Consultant, review and acceptance by the Consultant, shall not be considered as relieving the Contractor of the responsibility for completing the Work in accordance with the Contract.

12.2.7.3 Testing by the Contractor

The Contractor shall arrange for NDT testing in accordance with the following:

- 100% of all full penetration welded rail splices shall be inspected by radiographic testing;
- 100% of all HSS post base to baseplate full penetration groove welds shall be inspected by radiographic or ultrasonic testing; and
- 25% of post to baseplate fillet welds for W-Beam bridgerail and HSS pedestrian/cyclist barrier shall be tested and inspected using magnetic particle testing.

NDT shall be completed by a technician employed by a company that is certified to CSA W178.1. Magnetic particle inspection, ultrasonic and radiographic testing technicians shall be certified to Level II of CGSB. The methods of non-destructive examination shall be in accordance with the following standards:

- Radiography - AWS Standard D1.5
- Ultrasonic - AWS Standard D1.5
- Magnetic Particle - ASTM Standard E-709
- Dye - Penetrant - ASTM Standard E-165

The Contractor's testing and inspection records shall be open for examination by the Consultant upon request.

NDT and other inspection may also be performed by the Consultant or his designated testing agencies. The Contractor shall ensure full access to the Work all times to the Consultant or his testing agencies. When required by the Consultant, the Contractor shall provide required manpower for assistance in checking layout and performing inspection duties.

Testing, inspection and related costs incurred by the Consultant as a result of defective work shall be paid for by the Contractor.

The Contractor shall be responsible for all travel, boarding and lodging costs incurred by the Consultant to inspect bridgerail being fabricated outside the Province of Alberta. The cost shall also include for a Department's representative to attend the ~~pre~~pre-fabrication meeting and one additional trip during the course of fabrication.

~~12.2.7.2 Non-destructive Testing~~

~~The methods of non-destructive examination shall be in accordance with the following standards:~~

- ~~• Radiography - AWS Standard D1.5~~
- ~~• Ultrasonic - AWS Standard D1.5~~
- ~~• Magnetic Particle - ASTM Standard E-709~~
- ~~• Dye - Penetrant - ASTM Standard E-165~~

12.2.7.3—Testing by the Contractor

~~The Contractor shall be responsible for the cost of testing post to base plate weld as specified in clause 12.2.6.3 (b).~~

~~Testing and inspection made necessary by the repair of faulty work shall be paid for by the Contractor. All of the Contractor's records made in the course of quality control shall be open for examination by the Consultant.~~

12.2.7.4—Notification to Ship

~~The Contractor shall notify the Consultant 4872 hours prior to shipment to facilitate final inspection of the materials. Material inspection and acceptance of the bridgerail. Bridgerail shall not be shipped until it has been reviewed and accepted by the Consultant. Review and acceptance of bridgerail at the fabrication facility by the Consultant will not relieve the Contractor of his full responsibility to meet the requirements of these specifications.~~

~~Bridgerail that has not been inspected inat the fabrication plantfacility will not be paid for until such material has been inspected, reviewed and accepted by the Consultant. The Contractor mayshall be charged with responsible for all expensescosts incurred by the Consultant for inspection of the materialbridgerail not inspected at the sitefabrication facility.~~

12.2.8—Material Handling and Storage

~~All lifting and handling shall be done using devices that do not mark, mar, damage or distort the galvanized members and assemblies in any way. Galvanized material shall be stacked or bundled and stored to prevent wet storage stain as per the American Hot Dip Galvanizers Association (AHDGA) publication "Wet Storage Stain". Delivery of a damaged product will be aGalvanized steel exhibiting heavy wet stain shall have the staining removed before installation of the steel member. Items exhibiting extreme wet staining shall be cause for rejection of the member. Refer to the AHDGA publication "Wet Storage Stain" for information regarding heavy and extreme staining. Delivery of a damaged product will be cause for rejection.~~

12.2.9—Fabrication Outside of Canada

~~All testing and inspection requirements specified in Subsection 12.2.7, Testing and Inspection, shall be completed at the fabrication facility and all costs incurred by the Consultant and their designated testing agencies, and the Department shall be paid for by the Contractor.~~

~~All components fabricated outside of Canada shall be shipped to a shop located in Canada that is certified by CWB in accordance with CSA W47.1 to Division 1 or 2 for re-inspection and testing. The components shall be in a condition that facilitates all re-inspection and testing requirements. The re-inspection and testing at the Canadian shop shall be completed in accordance with Subsection 12.2.7, Testing and Inspection. The Contractor shall also arrange for inspection by a CSA 178.2 Level III certified welding inspector accredited with W47.1/W59 to inspect all components to ensure that they were undamaged during transportation.~~

Components shall not be shipped from the Canadian shop until all requirements have been met and the Work has been reviewed and accepted by the Consultant.

The Contractor shall be responsible for all re-inspection and testing costs, including all cost incurred by the Consultant and the Department.

The Contractor shall have no claim against the Department resulting from delays caused by these requirements.

### 12.3 Erection

Anchor ~~bolt~~rod assemblies shall be accurately positioned with anchor ~~bolt~~rod projections as shown ~~and specified on the Drawings.~~

The line and grade of the railing shall be true to that shown on the Drawings, and not follow any unevenness in the superstructure. It will be necessary to adjust the height and plumbness of each post, in order to compensate for normal superstructure variations, and achieve the desired line and grade on the bridgerail. Final railing elevations shall be set by instrument and the profile reviewed and accepted by the Consultant prior to grout placement.

Anchor ~~bolts that~~rods shall project ~~less than the full thickness~~ a minimum of the nuts, by more ~~than 2 threads,~~ above the top anchor rod nut after tightening is complete. Anchor rods that do not meet the minimum projection requirement shall be ~~extended.~~ Repaired or replaced. Proposed repair will require the acceptance of the Department and Consultant in writing and the repair procedures shall be ~~done at no cost~~ submitted to the Consultant and the Department. However, if for review and acceptance 2 weeks prior to commencement of the repair work.

All structural bolts shall be tightened using the turn of nut method described above is due to deficiency in Subsection 6.3.2.6, High Tensile Strength Bolted Connections after the grout has been placed, cured and achieved a compressive strength acceptable to the work of others, it will be paid for as "Extra Work". Consultant.

#### 12.3.1 Grouting of Base Plates

Grout used for the grouting of base plates shall be selected from the Alberta Transportation Product List, Non-Shrink Grout category.

The method of forming and pouring the grout shall be submitted to the Consultant for review and acceptance. Dry-pack methods of constructing grout pads will not be accepted.

~~All structural bolts shall be tightened by using turn of nut method as specified in Section 6.3.2.7.~~

Grout shall be packaged in waterproof containers with the production date and shelf life of the material shown. It shall be mixed and placed in strict accordance with the manufacturer's recommendations stated on their published product data sheet.

The Contractor shall utilize experienced ACI or CSA certified testers to test the compressive strength of the grout in accordance with CSA A23.2-1B. A set of compressive strength cubes shall be taken to represent each days production or 0.25 m<sup>3</sup>, whichever is more frequent. All test results shall be provided to the Consultant. The average minimum compressive strength of 3 cubes at 28 days shall be 30 MPa. Failure to meet the minimum specified compressive strength will result in the grout pad being removed and replaced at the Contractor's expense.

Grout shall be wet cured for a minimum of 3 days with two layers of clean, saturated Nilex 4504 white coloured filter fabric or an approved equivalent. Water used for wet curing shall be clean and acceptable to the Consultant.

Sealer shall be applied to the exposed grout pad surfaces in accordance with Section Subsection 4.26—“Type 1c Sealer”.

#### 12.3.1.1 ~~12.3.1~~—Grouting in Cold Weather

~~When the daily minimum air temperature, or the temperature of the bridgerail, the bridge substructure or superstructure in the immediate area of the grouting falls below 5°C, the following provisions for cold weather grouting shall be put into place:~~

~~(a) — Before~~ When the air temperature is, or is expected to be below 5 °C as forecasted by the closest Environment Canada Meteorological Station during the placing and curing period, or when determined by the Consultant, a cold weather grouting plan shall be implemented. The Contractor shall submit details of his proposed cold weather grouting plan to the Consultant for review and acceptance a minimum of 2 weeks prior to any grout placement.

The following minimum requirements for grouting, adequate preheat in cold weather shall be included in the cold weather grouting plan:

- Before placing grout, pre heat shall be provided to raise the temperature of the adjacent areas of the bridgerail, the bridge substructure and superstructure to at least 40 formwork, anchor rods, and substrate surfaces to between 10 °C, and 20 °C;
- (b) — Mixing water shall be heated to a temperature of at least 20 °C but not more than 65 °C;
- Temperature of the grout during placing shall be between 10 °C and 25 °C;
- (c) — The grout pad Grout shall be enclosed wet cured a minimum of 72 hours;
- The Contractor shall enclose the structure in such a way that the grout and air within the enclosure can be kept at 40°C to 25 or above 15 °C for at least a protection period of 5 days after placing the grout. Enclosures shall be constructed with a minimum 300 mm clearance between the enclosure concrete and/or grout surfaces; and
- Protection and heating, when used, shall be withdrawn in such a manner so as not to induce thermal shock stresses in the grout. The system temperature of heating the grout shall be designed gradually reduced at a rate not exceeding 10 °C per day to prevent excessive drying out of the grout that of the surrounding air. To achieve this, in an enclosure, the heat shall be slowly reduced.

12.3.2 The Contractor shall demonstrate to the satisfaction of the Consultant that the requirements of the cold weather concreting plan are met.

#### 12.3.2 Approach Rail Transition

The supply and installation of the approach rail transition including thrie beam or W-beam guardrail sections, W-thrie beam transition section, terminal connectors, steel or timber guardrail posts, spacers, and hardware as shown on the Drawings shall be included as Bridgerail. These materials shall be supplied and installed in accordance with Section 14—“Guardrail”, of the Specifications for Bridge Construction.

#### 12.4 ~~12.4~~ Payment

Payment for Bridgerail will be made on the basis the supply and installation of bridgerail, including approach rail transitions and guardrail connections, will be made at the lump sum price bid for “Bridgerail acceptably completed. The price bid shall include— Supply and Install”, and will be full compensation for the costs supply, fabrication and installation of furnishing the bridgerail; supply and placement of grout; and all labour, materials, equipment, tools, and incidentals necessary to supply, fabricate, and erect complete the bridgerail, including Work as shown on the approach rail transition Drawings and to the satisfaction of the Consultant.

All costs associated with grouting in cold weather, when required, will be considered incidental to the Work, and guardrail connection and wing end sections where specified. Payment for Bridgerail no separate or additional payment will be made at.

80% of the lump sum price bid ~~upon receipt and acceptance of the material at the~~will be paid once the bridgerail has been acceptably supplied and delivered to the bridge site. The remaining ~~payment~~20% of the lump sum price bid will be made afterpaid once the bridgerail ~~is suitably~~has been acceptably installed and ~~accepted by the Consultant.~~grouted.



STANDARD SPECIFICATIONS FOR BRIDGE CONSTRUCTION

SECTION 13 MISCELLANEOUS IRON

TABLE OF CONTENTS

<b>13.1</b>	<b>General</b> .....	<b>13-1</b>
<b>13.2</b>	<b>Supply, Fabrication and Installation</b> .....	<b>13-1</b>
<b>13.3</b>	<b>Galvanizing</b> .....	<b>13-1</b>
<b>13.4</b>	<b>Field Welding</b> .....	<b>13-2</b>
	13.4.1 Field Welding of Structural Members .....	13-3
	13.4.2 Field Welding of Non-Structural Members.....	13-3
<b>13.5</b>	<b>Payment</b> .....	<b>13-3</b>



### 13.1 General

~~Items included as~~ This specification is for the supply, fabrication, and installation of Miscellaneous Iron. Miscellaneous Iron will be ~~shall include any of the following items and those listed in the Special Provisions, and typically include of the following~~ Contract:

- Steel drain troughs;
- Pier drip sheets;
- Deck buffer angles;
- Dowels;
- Connector angles;
- Anchor bolt sleeves;
- Bridge plaques;
- Identification tags for culvert and overhead sign structures; and
- Bench mark tablets.

### 13.2 ~~13.2~~ Supply, Fabrication and Installation

Miscellaneous Iron shall be supplied, fabricated, ~~placed and erected~~ installed by the Contractor ~~as shown on the drawings or as specified in the Special Provisions and applicable portions of in accordance with Section 6 “Structural Steel”, the Drawings and these specifications. In the case of conflicting requirements, the requirements of this section shall govern.~~

~~Bridge plaques~~ Plaques, identification tags, and bench mark tablets shall be supplied, fabricated and installed in accordance with the Drawings and the following Standard Drawings:

- ~~S-1424 “1847, Standard Irrigation Canal Bridge and Small Bridge~~ Identification Plaques” and Benchmark Tablet; and
- ~~S-1477 “1848, Standard Large Bridge Plaque Installation Details”~~ Identification Tags.
- ~~S-1617 “Cast Aluminum Bridge Foundry Casting Details”~~

~~Bench mark tablets shall be supplied and installed by the Contractor in accordance with the construction drawings and the following standard drawing:~~

- ~~S-1478 “Standard Bridge Bench Mark Tablet Installation”~~

### ~~13.3 Handling Galvanized Steel~~

#### 13.3 All lifting and handling Galvanizing

The fabricator shall provide a smooth finish on all edges and surfaces, and remove all weld spatters, and all welding flux residue from the steel components prior to galvanizing.

Factors contributing to galvanization-induced cracking shall be minimized. Galvanizing shall be by the hot dip method, after fabrication, in accordance with the current edition of ASTM A123/A123M Standard Specification for Zinc (Hot-Dip Galvanized) Coatings on Iron and Steel Products and ASTM F2329 Standard Specification for Zinc Coating Hot-Dip Requirements for Application to Carbon and Alloy Steel Bolts, Screws, Washers, Nuts, and Special Threaded Fasteners and as modified in this specification.

The cleaning and pickling procedure of high strength ASTM A193 Grade B7 anchor rods shall be done using devices that do not mark, mar, damage or distort modified as follows prior to hot-dip galvanizing:

- Brush blast to remove mill scale and oil after threading ends;
- Flash pickle up to 5 minutes; and
- Quick dry prior to hot-dip galvanizing (not stored in flux or acid rinse).

The modified anchor rod cleaning and pickling procedure shall be completed in the presence of the Consultant prior to hot-dip galvanizing.

Repair of galvanizing shall be completed in accordance ASTM A780, Method A3 "Metallizing" and will only be permitted when the repair areas are small and infrequent as determined by the Consultant. Repair areas less than 100 mm<sup>2</sup> in area may be completed in accordance with ASTM A780, Method A1 "Repair Using Zinc-Based Alloy". The thickness of the coating for both methods shall be 180 µm, and the repair tested for adhesion. A detailed repair procedure shall be submitted for review and acceptance by the Consultant prior to commencement of the work. Repairs may require complete removal of the galvanized members and assemblies in any way, coating and re-galvanizing. The finished appearance shall be similar to the adjacent galvanizing as determined by the Consultant.

Galvanized material shall be stacked or bundled and stored to prevent wet storage stain as per the American Hot Dip Galvanizers Association (AHDGA) publication "Wet Storage Stain". Delivery of a damaged product will be a cause for rejection. Any evidence of wet storage stain shall be removed to the satisfaction of the Consultant.

#### **13.4 13.4—Field Welding of Miscellaneous Iron**

Metal core arc welding (MCAW) will not be permitted for field welding.

Low hydrogen filler, fluxes and welding practices shall be in accordance with Subsection 6.2.5.1, Filler Metals & Welding Processes.

13.4.1—When the ambient air temperature is below 10 °C, all material to be welded shall be preheated to 100 °C for a distance of 80 mm beyond the weld and shall be sheltered from the wind. When the ambient air temperature is below 0 °C, welding will not be permitted unless hoarding and heating acceptable to the Consultant is provided.

13.4.1 Field Welding of Structural Members

Members other than those listed in Subsection 13.4.2, Field Welding of Non-Structural Members, will be considered structural members.

~~Where the installation of Miscellaneous Iron includes field welding of structural members, the following requirements shall be met:~~

~~(Welding procedures, including welding procedure datasheets, shall be submitted for each type of weld proposed. The welding procedures shall bear the approval of the CWB and be reviewed and accepted by the Consultant a) — minimum of 3 weeks prior to the commencement of field welding.~~

All welding, cutting and preparation of structural members shall be completed in accordance with the American Welding Society (AWS) - Bridge Welding Code D1.5.

~~(b) — Only welders Welders shall be CWB approved by the Canadian Welding Bureau in the particular applicable category. Their qualifications shall be current and available for examination by the Consultant upon request.~~

13.4.2 Field Welding of Non-Structural Members shall be

The following will be considered non-structural members:

- Type 1 strip seal deck joint splices;
- Culvert struts;
- Stitch welding of steel caps/corbels; and
- Field welding of the end bulkheads on culvert liners.

Weld procedures shall be signed and sealed by a Professional Engineer registered in the Province of Alberta. Welding procedures shall be submitted to the Consultant for review and acceptance 1 week prior to commencement of field welding.

Journeyman welders with Class B tickets will be permitted to perform weldments of non-structural members. Their qualification shall be current and available for examination by the Consultant;

~~(c) Welding procedures approved by the Canadian Welding Bureau shall be submitted for review by the Department and Consultant prior to welding.~~

~~(d) Low hydrogen filler, fluxes and welding practices shall be used in accordance with 6.2.5.1.~~

~~(e) When the air temperature is below 10°C, all material to be welded shall be preheated to 100°C for a distance of 80 mm beyond the weld and shall be sheltered from the wind.~~

~~(f) When the air temperature is below 0°C, welding shall not be permitted unless suitable~~

~~hoarding and heating, accepted by the Consultant, is provided.~~

#### ~~13.4.2 Field Welding of Non-Structural Members~~

~~Where the installation of Miscellaneous Iron includes field welding of non-structural members, the following requirements shall be met:~~

- ~~(a) Journeyman welders with Class B tickets shall be permitted to perform weldments. Their qualification shall be current and available for examination by the Consultant.~~
- ~~(b) Welding procedures prepared and stamped by a Professional Engineer shall be submitted for review by the Department and Consultant prior to welding.~~
- ~~(c) Low hydrogen filler, fluxes and welding practice shall be used in accordance with 6.2.5.1.~~
- ~~(d) When the air temperature is below 5°C, all material to be welded shall be preheated to 100°C for a distance of 80 mm beyond the weld and shall be sheltered from the wind.~~
- ~~(e) When the air temperature is below 0°C, welding shall not be permitted unless suitable hoarding and heating, is provided.~~

~~Unless otherwise determined by the Consultant, the following are examples of non-structural field welding.~~

- ~~• Type 1 deck joint splices~~
- ~~• Culvert struts~~
- ~~• Stitch welding of steel caps/corbels~~
- ~~• Field welding of the end bulkhead on culvert liner~~

### ~~13.5 Payment~~

#### ~~13.5 Payment for Miscellaneous Iron~~

~~Payment will be made on the basis of at the lump sum price bid for "Miscellaneous Iron acceptably placed", and remaining in the completed work, which price shall include will be full compensation for the cost of furnishing all labour, materials, labour, equipment, tools and incidentals necessary to complete the Work. as shown on the Drawings and to the satisfaction of the Consultant.~~

STANDARD SPECIFICATIONS FOR BRIDGE CONSTRUCTION

SECTION 14 GUARDRAIL

TABLE OF CONTENTS

<b>14.1</b>	<b>General</b> .....	<b>14-1</b>
<b>14.2</b>	<b>Materials</b> .....	<b>14-1</b>
14.2.1	Rails and Terminal Elements .....	14-1
14.2.1.1	Rail Base Metal .....	14-1
14.2.1.2	Sheet Thickness .....	14-2
14.2.1.3	Sheet Width.....	14-2
14.2.2	Bolts, Nuts and Washers.....	14-3
14.2.3	Wood Posts .....	14-3
14.2.4	Steel Posts.....	14-3
<b>14.3</b>	<b>Inspection of Materials</b> .....	<b>14-4</b>
14.3.1	Guardrail Materials.....	14-4
14.3.2	Timber Material.....	14-4
<b>14.4</b>	<b>Installation</b> .....	<b>14-4</b>
<b>14.5</b>	<b>Payment</b> .....	<b>14-5</b>





## 14.1 General

This specification is for the supply, fabrication, delivery and installation of Modified Thrie Beamguardrail. Guardrail, ~~Strong Post W-~~ shall include modified thrie beam guardrail, Weakstrong post w-beam guardrail, Transitions, weak post w-beam Turn-Down End Terminals, and other approved crash-worthy end treatments. Work shall include all guardrail componentsguardrail, connections, treated timber posts, steel posts, winged and buried end sections, connections to other barriers and spacers, transitions, end terminals, Department approved crash-worthy end treatments, miscellaneous components and associated materials.

Drawings shall include ~~TEB Standard Drawings~~Alberta Transportation reference drawings from Appendix B of the Roadside Design Guide for approach guardrails, Bridge Engineering Standard Drawings for bridgerails and bridgerail/approach guardrailrail transitions, drawings in the AASHTO-AGC-ARTBA publication "A Guide to standardized Highway Barrier Hardware", and other Drawings provided in the Contract.

## 14.2 ~~14.2~~ Materials

### 14.2.1 ~~14.2.1~~ Rails and Terminal Elements

Thrie beam/W-beam guardrail shall consist of rail sections fabricated for installation to develop the continuous beam strength with the necessary safety and feature components.

All rail sections and other components shall match the design profiles and dimensions of the AASHTO/ARTBA hardware requirements for full interchangeability of similar components regardless of the source of manufacturer.

The rails and terminal elements shall be manufactured from open hearth, electric furnace or basic oxygen semi -spring steel sheet, all in general accordance with the AASHTO Standard Designation M180 and shall conform to the ~~TEB~~Roadside Design Guide reference drawings or the drawings in the AASHTO-AGC-ARTBA publication "A Guide to Standardized Highway Barrier Hardware".

Rails shall be punched for splice and post bolts in conformity with the AASHTO Standard to the designated number of and centre to centre spacing of posts. If holes are punched after galvanizing the galvanizing around the hole shall be repaired in accordance with sectionSubsection 12.2.6.7 ~~of the Specifications for Bridge Construction, Galvanizing.~~

Curved W -beam rails shall be formed to the radius specified in accordance with Reference Drawing TEB 3.54.

The rails and terminal elements shall be manufactured according to the following standards:

#### ~~14.2.1.1~~ Metal Properties

14.2.1.1 Rail Base Metal

Physical properties of the base metal for the rails shall ~~conform to meet~~ the following requirements:

~~Minimum Yield Point~~ 345 MPa

~~Minimum Tensile Strength~~ 483 MPa

~~Minimum Elongation~~ Minimum 12% outlined in 50 mm length Table 14-1, Rail Base Metal Physical Property Requirements.

14.2.1.2 Table 14-1: Rail Base Metal Physical Property Requirements

<u>Physical Property</u>	<u>Minimum Required Value</u>
<u>Yield</u>	<u>345 MPa</u>
<u>Tensile Strength</u>	<u>483 MPa</u>
<u>Elongation</u>	<u>12% in 50 mm length</u>

~~14.2.1.1~~ 14.2.1.2 Sheet Thickness

The rails and terminal elements thickness shall be manufactured according to Table 2 (Class A, Type II) of AASHTO Standard M180 ~~with nominal base metal thickness of 2.8 mm (2.57 mm minimum).~~

~~14.2.1.2~~ 14.2.1.3 ~~14.2.1.3~~ Sheet Width

Sheet width for the W -beam rail shall be 483 mm with a permissible tolerance of minus 3 mm.

Sheet width for the thrie beam rail shall be 750 mm with a permissible tolerance of minus 3 mm.

All welding required for the fabrication of terminal elements shall conform to the requirements of CSA W59M. Only welders, welding operators and tackers approved by the Canadian Welding Bureau in the particular category may be permitted to perform weldments.

All rails and terminal elements shall be ~~hot dip~~ galvanized ~~after fabrication conforming to in accordance with~~ the current edition of ASTM A123/A123M ~~Standard Specification for Zinc (Hot-Dip Galvanized) Coatings on Iron and Steel Products.~~

A copy of the producer's certificate, conforming to Section 16 of CSA G40.20M, for each of the mechanical and chemical tests, including impact tests, shall be provided to the Consultant ~~upon request~~ for review and acceptance.

#### 14.2.2 ~~14.2.2~~ Bolts, Nuts and Washers

All guardrail bolts, nuts and washers shall conform to ~~ASTM A307~~AASHTO Standard Designation M180, unless noted otherwise on the Drawings, and shall be hot dip galvanized ~~conforming to in conformance with~~ the current edition of ~~ASTM A153/A153M Standard Specification F2329~~. A copy of mill test reports shall be provided to the Consultant for ~~Zinc Coating (Hot Dip) on Iron and Steel Hardware~~ review and acceptance.

#### 14.2.3 ~~14.2.3~~ Wood Posts

Posts and offset blocks shall be Douglas Fir, Hemlock, Lodgepole Pine or better and shall meet the current edition of the National Lumber Grades Authority (NLGA) for No.1 Structural Posts and Timbers graded conforming to the NLGA Standard Grading Rules for Canadian Lumber.

Posts shall be date stamped at the top of either side of the post not used for rail attachment with the last two digits of the year of installation. The stamp shall be 50 mm x 50 mm and have an indentation of 3 mm.

Posts and offset blocks shall be rough sawn and holes drilled to the finished dimensions shown in Drawing TEB 3.01. Surfacing shall be completed and incised prior to treatment with allowable tolerance of 1.5 mm.

Wanes on any face shall not exceed ~~the following width:~~25 mm above ground (including blocks) or 60 mm below ground.

~~Above ground (including blocks)~~ 25 mm

~~Below ground~~ 60 mm

Posts and offset blocks shall be pressure preservative treated in accordance with the current requirements of CSA Standard 080.

The retention of preservatives shall be as per assay and shall conform to the requirements of CSA Standard 080.14 Table 1, minimum retention of preservatives in pressure treated wood for highway construction, under the headings "Post -Guardrail, Guide, Sign and Sight" for posts and "Bridge Hand Rails, Guard Rails and Posts" for timbers not in contact with the ground or water.

#### 14.2.4 ~~14.2.4~~ Steel Posts

Steel for posts, spacers and hardware shall conform to the requirements of CSA Standard G40.~~2121M~~ Grade 350W or ASTM ~~Standard~~ A36 and shall be hot dip galvanized after fabrication ~~conforming to in accordance with~~ ASTM A123/A123M ~~Standard Specification~~. A copy of mill test reports shall be provided to the Consultant for ~~Zinc (Hot Dip Galvanized) Coatings on Iron~~ review and ~~Steel Products~~ acceptance.

**14.3 ~~14.3~~—Inspection of Materials**

All guardrail materials shall be inspected and materials which fail to meet these specifications will be rejected, and shall be replaced or repaired at no cost to the Department.

**14.3.1 ~~14.3.1~~—Guardrail Materials**

The ~~size and~~ thickness of ~~2.67 mm nominal base metal thickness rails and terminal elements~~ finished Type II materials shall be ~~within the tolerance specified below~~; in accordance with AASHTO Designation M180 Table 2.

~~Base metal thickness~~ ————— ~~2.67 mm~~

~~Galvanized finished thickness~~ ————— ~~2.82 mm~~

~~Tolerance~~ ————— ~~0.23 mm~~

~~The size and thickness of 3.5 mm nominal base metal thickness rails and terminal elements shall be within the tolerance specified below:~~

~~Base metal thickness~~ ————— ~~3.43 mm~~

~~Galvanized finished thickness~~ ————— ~~3.58 mm~~

~~Tolerance~~ ————— ~~0.23 mm~~

**14.3.2 ~~14.3.2~~—Timber Material**

Testing of the penetration of the preservative may be carried out by the Consultant.

~~Warped wood posts will be rejected, as determined by the Consultant, shall be removed and replaced by the Contractor at his expense.~~

**14.4 ~~14.4~~—Installation**

The guardrail shall be connected as shown on the Drawings.

Guardrail shall be accurately set to the required depth and alignment, in a manner resulting in a smooth continuous installation, as shown on the Drawings or as ~~directed~~ determined by the Consultant. Permissible tolerance for plumb and grade of posts shall be  $\pm 20$  mm ~~maximum~~.

Holes for the guardrail posts shall be excavated by auger. The diameter of the holes augered shall be of sufficient size to allow for pneumatic tamping. Surplus excavated material and debris shall be removed from the site in a location and manner acceptable to the Consultant.

Unsuitable material at the bottom of the holes excavated shall be replaced with granular material at the Contractor's expense, as ~~directed~~ determined by the Consultant. The Contractor shall thoroughly compact the bottom of the hole. The guardrail posts shall rest directly and solidly on the bottom of the hole at the time of installation.

Excavated material which is unsuitable for use as backfill shall be replaced with granular material ~~meeting the requirements of in accordance with~~ Section 2.2.2 (Designation 2 Class 25). Backfill. Backfill shall be thoroughly compacted, using pneumatic tampers, in layers not exceeding 150 mm, for the full depth of the excavation. Where posts are installed on paved surfaces, the backfill for the top 150 mm shall be completed using ACP in accordance with Section 17, Asphalt Concrete Pavement.

Any guardrail material requiring field modification to fit shall be reported to the Department and Consultant for their acceptance of the modification method use before work is to be carried out. Modification by flame cutting method is prohibited. Modification by cold cutting method is allowed. Field guardrail modification is considered incidental to the work. Adequate edge distances of guardrail material shall be maintained during the modification process.

Guardrail laps shall be in the direction of traffic flow. Bolts shall be tightened to a torque of 100 Nm. Metal reflectors (Scotchlite or equivalent) shall be supplied and attached to the top of every third guardrail post with two 50 mm ring nails.

The Contractor shall take all necessary precautions to eliminate damage to galvanizing. Minor abrasions and exposed steel areas ~~resulting from cold cutting, as determined by the Consultant,~~ shall be repaired in accordance with ASTM A780 Method A2 ~~“Repair Using Paints Containing Zinc Dust”.~~ Major abrasions and exposed steel areas, as determine by the Consultant, shall be repaired by regalvanizing. The method to be used for repair of any damage replaced with new material. Repairs shall be accepted by the Consultant before such work is commenced. The Contractor shall repair or replace components completed to the satisfaction of the Consultant.

~~The guardrail shall be connected to bridgerail, parapets or existing guardrail as shown on the drawings.~~

~~Surplus excavated material and debris shall be removed from the site.~~

#### **14.5 ~~14.5~~—Payment**

Payment for **Guardrail** ~~will be made on the basis of the supply and installation of guardrail, excluding approach rail transitions and guardrail connections to approach rail transitions, will be made at~~ the lump sum price bid for guardrail acceptably placed and remaining in the completed work, which price shall include “Guardrail – Supply and Install”, and will be full compensation for ~~the cost of furnishing~~ all labour, materials, equipment, tools, and incidentals necessary to supply complete the Work as shown on the Drawings and to the satisfaction of the Consultant.

Payment for approach rail transitions and guardrail and all associated hardware connections to approach rail transitions will be made in accordance with Section 12, Bridgerail.



# STANDARD SPECIFICATIONS FOR BRIDGE CONSTRUCTION

## SECTION 15 NON-SKID POLYMER OVERLAY

### TABLE OF CONTENTS

<b>15.1</b>	<b>General</b> .....	<b>15-1</b>
<b>15.2</b>	<b>Materials</b> .....	<b>15-1</b>
15.2.1	Polymer.....	15-1
15.2.2	Degadur System (MMA).....	15-1
15.2.2.1	Initiator (MMA).....	15-2
15.2.2.2	Promoter (MMA).....	15-2
15.2.2.3	Degadur Basecoat (MMA).....	15-2
<b>15.3</b>	<b>Aggregates</b> .....	<b>15-3</b>
15.3.1	Seed Aggregate.....	15-3
15.3.2	Basecoat Filler Aggregate (Degussa Degadur System MMA).....	15-3
<b>15.4</b>	<b>Patching Materials</b> .....	<b>15-4</b>
<b>15.5</b>	<b>Crack Repair</b> .....	<b>15-5</b>
<b>15.6</b>	<b>Bridge Deck Repair</b> .....	<b>15-5</b>
15.6.1	Surface Patching.....	15-5
15.6.2	Partial and Full Depth Repair.....	15-6
15.6.3	Surface Defects and Tolerances.....	15-6
<b>15.7</b>	<b>Polymer Construction</b> .....	<b>15-7</b>
15.7.1	Surface Preparation.....	15-8
15.7.2	Deck Layout for the Overlay.....	15-8
15.7.3	Weather Conditions, Dryness of Concrete Substrate and Polymer Layers.....	15-8
15.7.4	Batching and Mixing of Polymer.....	15-9
15.7.5	Application of Polymer Resin.....	15-9
15.7.5.1	Degadur Base Coat (MMA).....	15-10
15.7.5.2	Degadur Sealer (MMA).....	15-10
15.7.6	Seeding of Aggregate.....	15-11
15.7.7	Smoothness of Overlay Surface.....	15-11
15.7.8	Testing and Strength Requirements.....	15-12
15.7.9	Opening to Traffic.....	15-14
<b>15.8</b>	<b>Payment</b> .....	<b>15-14</b>





## 15.1 General

Resurfacing concrete bridge decks with non-skid polymer wearing surface consists of the repair of deck concrete, and application of a thin, flexible, multi-layered, polymer-aggregate wearing surface. This specification shall be used in conjunction with the “Specification for the Supply of Polymer Resins used in Polymer Overlays (B405)” and “Specification for Seed Aggregates used in Polymer Membranes and Overlays (B392)”. The work includes mobilization, traffic accommodation, surface preparation and patching.

The Degussa Degadur System (MMA) is an approved alternate for the polymer overlay as specified. The Degussa Degadur System (MMA) does not meet the compressive strength and physical requirements of the “Specification for the Supply of Polymer Resins used in Polymer Overlay (B405)”, and is applied in a different manner, but all other requirements of the specification shall still apply.

## 15.2 ~~15.2~~ Materials

All polymer materials including aggregates shall be protected from moisture, dust, or other contaminants. Any wet or otherwise contaminated materials will be rejected.

### 15.2.1 ~~15.2.1~~ Polymer

The polymer and the polymer mortar shall meet the requirements of the “Specification for the Supply of Polymer Resins used in Polymer Overlay (B405)”.

The following products are currently approved by the Department for use in this work:

- Flexolith
- Flexogrid Degadur System (MMA)

### 15.2.2 ~~15.2.2~~ Degadur System (MMA)

The DEGADUR B71 primer, DEGADUR 330 basecoat, and DEGADUR 410 sealer resins shall have the specified properties at the age of seven days ~~noted below, conforming to Table 15-1:~~ Properties of Degadur Resins.

**PROPERTIES OF DEGADUR RESINS**

**Table 15-1: Properties of Degadur Resins**

Property	Units	Primer	Basecoat	Sealer	Test Method
Density	g/cm <sup>3</sup>	1.05	1.01	0.98	-----
Viscosity* <u>@ time of mixing</u>	cps	220-330	1100-1300	450-550	ASTM D2393
Hardness	Shore D	83	56	61	ASTM D2240
Water Absorption	%	0.1	0.1	0.1	ASTM D570
Tensile Strength	MPa	29	8	9	ASTM D638
Elongation @ Break	%	3	300	140	ASTM D638

\* at time of mixing

15.2.2.1 ~~15.2.2.1~~—Initiator (MMA)

The initiator for the MMA resins shall be a 50% Benzoyl Peroxide powder such as AKZO Chemicals Inc., CADOX BFF -50, or an approved equivalent. Dosage rates shall be in accordance with the MMA Manufacturer's recommendations issued in the Degadur Catalyst Design Table.

15.2.2.2 ~~15.2.2.2~~—Promoter (MMA)

The promoter required for use with the MMA resins at application temperatures below 4°C shall be N, N -Dimethyl--p--toluidine such as R.S.A. Corporation DMPT or an approved equivalent. Dosage rates shall be according to the MMA Manufacturer's recommendations.

15.2.2.3 ~~15.2.2.3~~—Degadur Basecoat (MMA)

The basecoat shall have the specified properties at the age of seven days noted below conforming to Table 15-2: Properties of Degadur Basecoat:

**PROPERTIES OF DEGADUR BASECOAT**

**Table 15-2: Properties of Degadur Basecoat**

Property	Units	Required Value	Test Method
Compressive Strength* <u>(1)</u>	MPa	16-21	ASTM C109
Tensile Strength	MPa	3-5	ASTM D638

Elongation @ Break	%	6	ASTM D638
Flexural Strength	MPa	9-10	ASTM C580 mod
Freeze/Thaw Resistance	- -	Pass	ASTM C666
Bond Strength to Concrete	MPa	1.7 minimum	ACI 503R
Coefficient of Thermal Expansion	10E-5/K	7.9	DIN
Vicat Temperature	°C	50	DIN

**\*Notes:**

(1) Samples shall consist of 1 volume of Degadur Basecoat to 1 volume of Steilacoom.

The tests listed shall be conducted by a CSA approved testing lab, and shall include infrared and gas chromatography analysis (in accordance with BT008 Test Procedure for Finger Printing Sealers Using Infrared Spectroscopy and Gas Chromatographic Separation) for each component. All tests, including the spectro -analysis, shall be done on the same samples of material.

**15.3 ~~15.3~~—Aggregates****15.3.1 ~~15.3.1~~—Seed Aggregate**

The overlay aggregate provided by the Contractor shall conform to the current “Specification for Seed Aggregates Used in Polymer Membrane and Overlays” (B392). The seed aggregates currently approved by the Department are Indag # 8 and Steilacoom 6X10 Bridge Topping.

**15.3.2 ~~15.3.2~~—Basecoat Filler Aggregate (Degussa Degadur System MMA)**

Materials used in the basecoat shall consist of clean, dry (less than 0.2% moisture), angular grained silica sand and shall be free from dirt, clay, asphalt, and other organic materials. Materials sieve analyses shall conform to ~~the following sieve analyses:~~ Table 15-3: Gradation of Basecoat Filler Aggregates (MMA):

**Table 15-3: Gradation of Basecoat Filler Aggregates (MMA)**

<b><u>GRADATION OF BASECOAT FILLER AGGREGATES (MMA)</u></b>		
<b><u>Gradation</u></b>	<b><u>Basaltic Sand</u></b>	<b><u>0.045 mm Ground Silica Flour</u></b>
<b><u>A minimum of 90% shall pass the 0.045 mm sieve.</u></b>	<b><u>% Passing</u></b>	<b><u>% Passing</u></b>
<b><u>4.750 Basaltic Sand</u></b>	<b><u>99 – 100</u></b>	<b><u>n/a</u></b>
<b><u>2.360</u></b>	<b><u>92 – 100</u></b>	<b><u>n/a</u></b>

<u>1.000</u>							<u>61 – 70</u>	<u>n/a</u>					
<u>0.600</u>							<u>45 – 65</u>	<u>n/a</u>					
<u>0.300</u>							<u>10 – 20</u>	<u>n/a</u>					
Sieve, mm	<u>4.750</u>	<u>2.360</u>	<u>1.000</u>	<u>0.600</u>	<u>0.300</u>	<u>0.150</u>	<u>0 – 10</u>	<u>n/a</u>					
<u>0.045% Passing</u>							<u>99- 100n/a</u>	<u>92- 90 - 100</u>	<u>61- 70</u>	<u>45- 65</u>	<u>10- 20</u>	<u>0- 10</u>	

#### 15.4 ~~15.4~~ Patching Materials

Type NH patching materials meeting the requirements of “Specification for the Supply of Bridge Concrete Patching Materials” (B391) may be used in place of concrete in partial depth repair provided they are used in accordance with the manufacturer's instructions.

Samples of the mixed patching material will be tested by the Contractor according to ASTM C109 and in compliance with the Frequency of Test Table included in ~~Clause 15.7.8~~ “Testing and Strength Requirements”, Subsection 15.7.8, Testing and Strength Requirements. The average of three cubes will be used for acceptance and determination of payment range or rejection of the work as specified in ~~the table below.~~ Table 15-4: Patching Materials Payment Range.

**Table 15-4: Patching Materials Payment Range**

<b>28 Day Minimum Compressive Strength as per Manufacturers Specified Strength Requirement</b>	<b>Amount of Payment</b>
100% and above	Full bid price
90% to 99.9%	Bid price less \$25.00 per square metre
80% to 89.9%	Bid price less \$50.00 per square metre
70% to 79.9%	Bid price less \$100.00 per square metre
65% and below	Will be rejected

The Contractor shall pay all costs for testing, including but not limited to making test cubes, transporting cubes to an independent certified testing laboratory of his choice, storage, curing, breaking and providing written reports of the test results to the Consultant.

All patches consisting of Type NH patching materials shall be cured for 14 days and tested for moisture in accordance with ~~section 15.7.3~~ Subsection 15.7.3, Weather Conditions, Dryness of Concrete Substrate and Polymer Layers prior to the application of polymer overlay.

**15.5 ~~15.5~~—Crack Repair**

All deck cracks more than 2 metres in length and greater than 0.3 mm wide shall be treated with a Type 1c sealer meeting the current “Material Testing Specifications for Concrete Sealers” (B388). Application of the sealer shall be prior to shotblasting of the concrete deck, and shall consist of a 100 mm strip applied at the coverage rate as shown on the Approved Type 1c Sealer List. Payment for crack repair will be considered incidental to the Contract and no separate or additional payment will be made.

**15.6 ~~15.6~~—Bridge Deck Repair**

Bridge deck repair consists of; Surface Patching, Partial Depth Repair, or Full Depth Repair conforming to Table 15-5: Bridge Deck Repair Types, Depths, Materials and Description:

**Table 15-5: Bridge Deck Repair Types, Depths, Materials and Description**

Type of Patch	Depth of Patch (mm)	Repair Material	Description
Surface Patching	6 to 15	Polymer Mortar	Removal of surface deterioration without exposing rebar
Partial Depth Repair	15 to 200	Concrete	Chipping below corroded rebar and sandblasting of rebar is required
Full Depth Repair	Full depth of deck	Concrete	Forming of the underside of the deck is required

The concrete to be used for Partial and Full Depth Repair shall be Class HPC as specified in Section 4 “Cast-In-Place Concrete” of the Specifications for Bridge Construction.

**15.6.1 ~~15.6.1~~—Surface Patching**

The Contractor shall patch surface voids and depressions in excess of 6 mm. The Consultant shall determine the area to be patched.

Polymer mortar, applied in accordance with the Manufacturer's instructions and these specifications, shall be used where surface patching is required. The patching polymer mortar shall consist of 3½-4½ volumes of an approved aggregate to each volume of polymer. The mortar shall yield a 40 MPa minimum compressive strength when tested at 7 days using 50 mm cube specimens, as described in Clause ~~15.7.8~~ “Testing and Strength Requirements”-Subsection 15.7.8, Testing and Strength Requirements.

Prior to placement of the polymer mortar, the surface of the concrete shall be shotblasted and/or sandblasted in accordance with Clause 15.7.1 “Surface Preparation”-Subsection 15.7.1, Surface Preparation.

The areas to be patched shall be primed with a 75 mm wide band of liquid polymer along their perimeter. The polymer mortar surface patch shall be placed while the liquid polymer primer is liquid or tacky, and to the original gradeline or as directed by the Consultant.

Measurement and mixing of polymer components and aggregates shall be done in accordance with ~~Clause 15.7.4 “Batching and Mixing of Polymer”~~. Subsection 15.7.4, Batching and Mixing of Polymer.

Aggregate shall be placed over the fresh patch in sufficient quantity to ensure a rough surface for bonding to the polymer overlay. Smooth textured patches will be rejected.

When the Degussa Degadur System is used, the surface patching of the deck and curb shall be done with an approved 100% solids MMA mortar supplied by the Manufacturer of the methacrylate polymer overlay. Application shall be completed according to the Manufacturer's instructions.

Payment for Surface Patching will be made at the unit price bid per square metre of surface patching, which price shall include surface preparation, full compensation for the cost of furnishing all labour, equipment, materials, tools and incidentals necessary to complete the work.

#### 15.6.2 ~~15.6.2~~ Partial and Full Depth Repair

In areas where partial depth and full depth repair are required, ~~Clauses~~ Subsection 20.4.2—“Partial Depth Repair” and Subsection 20.4.3—“Full Depth Repair” shall apply.

All concrete shall be cured for 28 days and tested for moisture in accordance with ~~Clause 15.7.3~~ Subsection 15.7.3, Weather Conditions, Dryness of Concrete Substrate and Polymer Layers prior to the application of polymer overlay.

#### 15.6.3 ~~15.6.3~~ Surface Defects and Tolerances

The requirements for all new surface patching, partial and full depth repair shall conform to ~~Clause~~ Subsection 4.16.6—“Surface Defects and Tolerances”.

All patching and levelling requires acceptance by the Consultant prior to commencing the overlay. Failure to obtain acceptance may be cause for rejection of the overlay.

**15.7 15.7—Polymer Construction**

~~The polymer coverage rates shown below~~The polymer coverage rates shown in Table 15-6: Minimum Polymer Coverage Requirements, and Table 15-7: Minimum MMA Polymer Coverage Requirements for Degussa Degadur System (MMA) are based on undiluted polymer applied to a clean shotblasted deck surface or previously applied seeded polymer layer. Where the deck surface is spalled, scaled, or roughened by surface preparation, to depths up to 6 mm, the coverage rates shall be increased. Additional polymer material may also be required due to coarse texturing or grooving of the deck surface, or porosity of the concrete. The first layer shall extend up the full height of the vertical face of curbs and medians, and up 200 mm on the vertical faces of parapets. The Contractor shall obtain the Consultant's acceptance prior to increasing, for any reason, the minimum polymer coverage requirements. No separate or additional payment will be made for any additional polymer required.

**Table 15-6: Minimum Polymer Coverage Requirements**

<b>MINIMUM POLYMER COVERAGE REQUIREMENTS</b>			
<b>(P/m<sup>2</sup>)</b>			
<b>Wearing Surface Class</b>	<b>1st Layer (ℓ/m<sup>2</sup>)</b>	<b>2nd Layer (ℓ/m<sup>2</sup>)</b>	<b>3rd Layer (ℓ/m<sup>2</sup>)</b>
A	1.33	2.00	0.30
B	1.33	2.00	N/A
C	1.33	0.30	N/A

**Table 15-7: Minimum MMA Polymer Coverage Requirements for Degussa Degadur System (MMA)**

<b>MINIMUM MMA POLYMER COVERAGE REQUIREMENTS</b>			
<b>FOR DEGUSSA DEGADUR SYSTEM (MMA)</b>			
<b>(P/m<sup>2</sup>)</b>			
<b>Wearing Surface</b>	<b>Primer Layer (ℓ/m<sup>2</sup>)</b>	<b>Premixed Basecoat Layer (ℓ/m<sup>2</sup>)</b>	<b>Sealer Layer (ℓ/m<sup>2</sup>)</b>
Degussa Degadur System	0.40	5.00	0.67

---

**15.7.1 ~~15.7.1~~—Surface Preparation**

In order to prevent bond failures at overlay edges at high impact locations, 10 mm deep by 10 mm wide grooves shall be cut by router or saw and sandblasted in close proximity and parallel to all deck joints, snow slots, deck drains and all other transverse edges. These grooves or keys are intended to provide increased anchorage for the overlay and shall be filled with polymer and seeded in conjunction with application of the first layer. Rough spots exceeding 3 mm in height on or adjacent to, deck joints shall be ground to provide a smooth transition prior to placement of the overlay.

Proper surface preparation is essential to ensure adequate bond strength between the polymer wearing surface and deck concrete. The deck concrete surface shall be prepared by shotblasting to remove all bond inhibitors including concrete laitance, asphaltic material, sealers and oil, and to expose the coarse aggregate in the substrate concrete. Those areas which are inaccessible to shotblasting, such as the vertical faces of the curbs, medians, and parapets shall be similarly prepared by sandblasting.

If in the opinion of the Consultant, reblasting is required in the event of rain, delay in applying the overlay, or subsequent leakage onto the deck of other contaminants, it shall be done at the Contractor's expense.

**15.7.2 ~~15.7.2~~—Deck Layout for the Overlay**

Prior to the application of each layer, the Contractor shall submit a sketch to the Consultant showing the deck surface divided into segments which will be covered by each polymer batch. The length of each segment shall be determined by taking into account the overlay width, vertical faces, surface roughness, coverage rate, the amount of polymer in each batch, and losses in application equipment and containers.

After review of the sketches by the Consultant, the Contractor shall apply masking tape to the boundaries of the work area, except where these boundaries abut an existing polymer overlay mat of the same layer. The end of each overlay segment shall be marked at these boundaries. For the first layer only the layout area shall extend up the full height of the vertical curb and median faces and up 200 mm on the vertical faces of parapets. No overlay work shall commence until all layout by masking tape has been acceptably completed.

**15.7.3 ~~15.7.3~~—Weather Conditions, Dryness of Concrete Substrate and Polymer Layers**

The work shall be done in suitable conditions of temperature, wind, dust, and moisture. If weather factors or moisture conditions of the substrate concrete are detrimental to the acceptable placement of overlay, the work shall be suspended until suitable conditions exist. Mixing, placing and curing of polymer shall be done at ambient air and substrate concrete temperatures between 10°C and 27°C.



The concrete substrate, including concrete patching and repairs shall be completely dry before the first layer of polymer is applied. Subsequent layers of polymer shall not be applied until previous layers are completely cured. Presence of moisture will be determined by the modified ASTM D4263, "Standard Test Method for Indicating Moisture in Concrete by Plastic Sheet Method". This test shall be carried out on the concrete substrate as well as on previous placed polymer overlays. The Contractor shall place a minimum of four test windows, per application area, at different time periods. The test windows shall consist of three layers of clear and one layer of black heavy duty ~~6-mil~~ mil poly, 1000 mm x 500 mm located in moisture prone areas. The test windows shall be heated at a temperature of 55°C continuously for a time period of 6 hours for each test and at a time duration, period and frequency of test, as determined by the Consultant. Timing of the test windows shall not start until the temperature of the concrete surface has reached 55°C. This will not relieve the Contractor from his responsibility to ensure that the overlay does not debond. The Contractor shall provide four, 500 watt halogen lamp and a portable electric generator (3500 watt) and carry out the required testing which will be considered incidental to the Contract and no separate or additional payment will be made.

Application of the first layer is recommended when there is sufficient evidence of declining deck concrete temperatures.

#### 15.7.4 ~~15.7.4~~ Batching and Mixing of Polymer

Batching and mixing shall be done in accordance with the Manufacturer's instructions. The polymer shall be completely and thoroughly mixed before being deposited onto the deck. Any polymer not meeting the specification will be rejected, removed, and replaced at the Contractor's expense.

The temperature of the unmixed polymer constituents shall be between 10°C and 27°C. The polymer material shall be mixed in batches no larger than 20 l. Each component shall be measured to within an accuracy of 3%. All containers shall be clean and free of contaminants of hardened polymer. Containers used for mixing and blending shall not be used for measuring.

In the absence of the Manufacturer's time limit for mixing, the minimum time for mixing shall be 3 minutes, however, for the Degussa Degadur System, the mixing time is a function of temperature. Attention shall be taken to blend the polymer adjacent to the mixing container surfaces. The presence of air, water bubbles or other contaminants in the mixed polymer will be cause for rejection of that batch.

The deck and adjacent areas shall be protected from spillage of polymer, solvents, and other materials. Any spilled materials shall be removed by the Contractor.

#### 15.7.5 ~~15.7.5~~ Application of Polymer Resin

Upon the Consultant's acceptance of the prepared deck surface and completion of the layout, the polymer shall be applied in accordance with the Manufacturer's instructions regarding mixing, blend time, temperature, time between layers, pot life, method of application, condition of substrate and any other requirements.

All cold joints in the overlay shall be offset 25 mm from cold joints of previous layers of the overlay. To ensure straightness, masking tape shall be applied along the perimeter of all areas to be overlay as well as along all steel deck joints, drains, curb faces or other edges of the layers of overlay. The first layer of polymer shall extend up the full height of the concrete curb and median faces and up 200 mm on the vertical faces of parapets. All masking tape used to define the boundaries of each segment shall be completely removed prior to gelling of the polymer.

The Contractor shall spread the polymer uniformly over the premeasured area using a squeegee and roller brush to carefully work the polymer into the surface and obtain the required coverage. Spiked footwear will be permitted for use by workers involved in the application work, but only prior to gelling of the polymer and with the constraint that all damage or defects in the surface will be repaired. Spreading and levelling of fresh polymer shall be completed while the material is in a state of low viscosity, and within seven minutes of batching. Failure to comply with the seven minute limit may result in rejection of the batch. Application of material which has begun to gel and increase in viscosity will not be permitted.

Application of the third layer of polymer (tie coat) shall be by airless spraying only. The polymer shall not be cut back with any solvents. This does not apply to the Degussa Degadur System, where the sealer layer may be applied with a roller.

The Contractor shall prevent or repair all bubbles, blisters, pinholes or other defects.

#### 15.7.5.1 ~~15.7.5.1~~—Degadur Base Coat (MMA)

The basecoat mixture shall be prepared by blending the silica flour and basaltic sand components with the resin in a suitable container (e.g. 20 l pail), followed by the addition and subsequent blending of the initiator. The mixture shall be applied over clean, dry, cured primer surfaces at the coverage rate specified in ~~Clause 15.7, “Polymer Construction”~~, Subsection 15.7, Polymer Construction, using an approved spreading method. The applicator shall take care to allow the ridges between passes to self-level before broadcasting aggregate. Small areas may be touched up with a steel trowel.

The deck layout may be subdivided into coverage areas corresponding to a maximum of 150 l of MMA mix rather than 20 l as specified in ~~Clause 15.7.2 “Deck Layout for the Overlay”~~, Subsection 15.7.2, Deck Layout for the Overlay.

Applicators shall not walk on a polymer layer after 4 minutes from time of placement.

#### 15.7.5.2 ~~15.7.5.2~~—Degadur Sealer (MMA)

The sealer mixture shall be applied to the cured and swept basecoat using paint rollers and brushes. Application shall be in a “dip and roll” manner from containers holding no more than 8 l at a time; sealer shall not be poured directly onto the deck.

#### 15.7.6 ~~15.7.6~~ Seeding of Aggregate

The Contractor shall seed the first and second layer of polymer for Class A and B wearing surfaces and the first layer for Class C wearing surfaces. When the Degussa Degadur System (MMA) is used, the basecoat layer shall be seeded. The full height of the vertical face of curbs and median and up 200 mm of the vertical faces of the parapets shall not be seeded. The aggregate shall be seeded into the fresh polymer before gelling or increase in viscosity occurs. It shall be broadcast into the fresh polymer in such a manner that no ripples or waves are created and no segregation of the aggregate occurs. The aggregate shall impact the fresh polymer surface in a near vertical direction. Improper seeding technique will result in the work being suspended until proper methods are employed. The aggregate shall be placed so that an excess quantity covers the entire surface of the fresh polymer, no polymer is visible, and the surface has a dry appearance. As the aggregate settles into the fluid polymer, all “wet” spots which appear in the surface shall be promptly re-seeded before the polymer becomes viscous. At no time shall the Contractor disturb previously placed aggregate in an effort to cover “wet” surface spots. Once gelling begins, walking on the overlay will not be permitted until it has properly cured.

If insufficient aggregate has been placed and the “wet” areas harden to form glassy, resin-rich areas, the Contractor shall remove these areas to sound concrete, redo the deck surface preparation and replace the overlay.

After curing of the previous placed overlay and on acceptance of the Consultant, all excess aggregate or other contaminants shall be removed by power sweeping and air blasting. After cleaning to the satisfaction of the Consultant, the subsequent layer of polymer shall be applied.

Additional cleaning will be required if application of the subsequent layer of polymer is delayed and the overlay surface has become contaminated.

In the event that any layer of polymer material is subjected to rain or any other form of damage, the contractor shall do vertical pull out tests to confirm the adequacy of the material. This test consists of bonding a 64 mm diameter sandblasted steel disk to the prepared substrate by using an approved polymer, and pulling it from the substrate by applying a vertical force.

The polymer overlay in question will not be accepted unless at least 75% of the bonded steel disk surface has retained substrate concrete exceeding 3 mm in depth. At the discretion of the Consultant the pull-out test may be carried out on any polymer layer. The minimum acceptable bond strength on normal weight concrete shall be 3.0 MPa. The Contractor shall repair all bond test locations with polymer overlay in accordance with this specification. The pull out equipment and repair of the polymer overlay will be considered incidental to the Contract.

#### 15.7.7 ~~15.7.7~~ Smoothness of Overlay Surface

Larger smoothness defects of the bridge deck, as determined by the Consultant shall be repaired by surface patching. Minor defects inherent in the concrete deck shall be smoothed by the application of the polymer overlay.

Roughness attributable to the overlay will be tested with a 3 m long straight edge. When placed anywhere in any direction on the surface except across the crown, the gap between the bottom of the straight edge and the surface of the overlay shall not exceed 3 mm. Overlays not meeting the criteria will be rejected, removed and replaced at the Contractor's expense.

The location and number of measurements taken will be at the discretion of the Consultant.

15.7.8 ~~15.7.8~~ Testing and Strength Requirements

Two weeks prior to commencement of work, the Contractor shall be responsible for testing of infrared and gas chromatography analysis (in accordance with BT008) for each polymer component, compressive strength of the polymer mortar, modulus elasticity of the polymer, and grain size analysis of the aggregate. These results shall be provided to the Consultant for review.

During placement of the polymer, samples of the mixed polymer material will be randomly selected by the Consultant and the Contractor shall cast sets of three 50 mm cubes for compressive strength testing in accordance with test method ASTM C -109. These tests will be used for acceptance and determination of payment range or rejection of the work as specified in the applicable table below entitled "Partial Payment Schedule". The test cubes will be cast at a ratio of ~~22~~22 volumes of approved aggregate to 1 volume of mixed polymer and cured for seven days in dry lab conditions. When the Degussa Degadur System is used, the test cubes will be cast at a ratio of 1 part base coat and 1 part approved aggregate, by volume and cured for seven days.

The compressive strength will be the maximum load measured or the load causing a 2.5 mm deflection, whichever occurs first. (This modified ASTM C -109 test method will also be used for acceptance testing of proposed overlay materials.) The compression test will be done using a steady loading rate of 0.5 MPa  $\pm$ 0.05 MPa per second.

The acceptable range of 7 -day compressive strength for the polymer shall be 40 MPa to 70 MPa.

The MMA product shall have a 7 -day compressive strength range of 16 MPa or over.

The Department reserves the right to reject any overlay whatsoever which does not meet the applicable strength requirements. The Department may however, at the discretion of the Consultant, accept overlay which fails to meet the compressive strength range. In this case payment will be made in accordance with ~~the following tables.~~ Table 15-8: Partial Payment Schedule for Low Strength Polymer and Table 15-9: Partial Payment Schedule for Low Strength MMA Overlay.

**PARTIAL PAYMENT SCHEDULE FOR LOW STRENGTH POLYMER****Table 15-8: Partial Payment Schedule for Low Strength Polymer**

7-Day Compressive Strength (MPa)	Percentage of Unit Price
Between 40.0 and 70.0	100
38.0 to 40.0 or 70.0 to 72.0	90
36.0 to 38.0 or 72.0 to 74.0	80
34.0 to 36.0 or 74.0 to 76.0	70
32.0 to 34.0 or 76.0 to 78.0	60
30.0 to 32.0 or 78.0 to 80.0	50
Below 30.0 or over 80.0	Rejected

**PARTIAL PAYMENT SCHEDULE FOR LOW STRENGTH MMA OVERLAY****Table 15-9: Partial Payment Schedule for Low Strength MMA Overlay**

7-day Compressive Strength (MPa)	Percentage of Unit Price
16 and Over	100
15.0 to 15.9	90
14.0 to 14.9	80
13.0 to 13.9	70
12.0 to 12.9	60
11.0 to 11.9	50
Below 11.0	Rejected

Compressive strength tests may be carried out on any layer of the overlay. If a test result of any layer is below that specified, the reduced unit price shall apply to the full overlay thickness. Where compressive strength tests have been done on more than one layer, the lowest strength test result will be used to determine adjustment of the unit price. Each test will represent the 100 m<sup>2</sup> area poured during that batching operation. The Consultant will determine the test location of each test. The Contractor shall cast a set of three cubes to the frequency of test listed in ~~the following table:~~ Table 15-10: Frequency of Test.

<b>Frequency of Test</b>
--------------------------

**Table 15-10: Frequency of Test**

Deck Area (m <sup>2</sup> )	No. of Tests (Set of 3 Cubes)
1 - 500	4
501 - 1000	8
1001 - 2000	14
2001 - 3000	20
3001 - 4000	24

The Contractor shall pay all costs for testing, including but not limited to making test cubes, transporting cubes to an independent certified testing laboratory of his choice, storage, curing, breaking, and providing written reports of the polymer test results to the Consultant.

15.7.9 ~~15.7.9~~ — Opening to Traffic

The polymer overlay surfaces shall not be opened to traffic until a minimum of 60% of the 7 day compressive strength or 3.0 MPa of tensile strength is achieved based on the last batch of the day. It is recommended that the Contractor casts one additional set of cubes from the last batch of the day and have these tested at his cost. The cubes shall be cured in the field at ambient air temperature prior to testing.

No traffic will be allowed on the polymer overlay until all layers are acceptably placed and confirm to the strength requirement.

~~15.8~~ — Payment

**15.8 Payment for Polymer Wearing Surface**

Measurement for payment of non-skid polymer overlay will be by the square metre of acceptably treated area, measured to the nearest 0.1 m<sup>2</sup>.

Payment will be made at the unit price bid ~~per square metre of deck resurfaced, which price shall include surface preparation, for “Non-Skid Polymer Overlay”, and will be~~ full compensation for ~~the cost of furnishing~~surface preparation; the supply and application of polymer overlay; and all labour, equipment, ~~materials,~~ tools and incidentals necessary to complete the Work. ~~The areas of the curb, median, deck joint or parapet vertical faces will be considered incidental and will not be included in the area as shown on the Drawings and to the satisfaction of polymer wearing surface to be paid.~~the Consultant.





STANDARD SPECIFICATIONS FOR BRIDGE CONSTRUCTION

**SECTION 16 BRIDGE DECK WATERPROOFING**

TABLE OF CONTENTS

<b>16.1</b>	<b>General</b>	<b>16-1</b>
<b>16.2</b>	<b>Material</b>	<b>16-1</b>
16.2.1	General	16-1
16.2.2	Submittals	16-1
16.2.3	Sampling and Testing	16-1
16.2.4	Materials	16-1
16.2.4.1	Asphaltic Primer	16-1
16.2.4.2	Asphalt Membrane	16-1
16.2.4.3	Rubber Membrane	16-2
16.2.4.4	Membrane Reinforcing Fabric	16-2
16.2.4.5	Wick Drain	16-2
16.2.4.6	Waterproofing Protection Board	16-2
<b>16.3</b>	<b>Equipment</b>	<b>16-2</b>
<b>16.4</b>	<b>Installation</b>	<b>16-2</b>
16.4.1	General	16-2
16.4.2	Traffic Restriction	16-3
16.4.3	Surface Preparation	16-3
16.4.3.1	Grout Tubes	16-3
16.4.3.2	New Bridge Construction	16-3
16.4.3.3	Bridge Rehabilitation	16-3
16.4.4	Application of Asphaltic Primer	16-4
16.4.5	Waterproofing of Joints and Cracks	16-4
16.4.6	Application of Asphalt Membrane	16-5
16.4.7	Wick Drain Installation	16-5
16.4.8	Protection Board Installation	16-5
<b>16.5</b>	<b>Measurement and Payment</b>	<b>16-6</b>



## 16.1 General

This specification is for the supply and installation of ~~bridge-deck~~ hot applied asphalt waterproofing.

~~Bridge-deck system.~~ Waterproofing shall be carried out in accordance with the following specifications; as shown on the Drawings and Standard ~~drawing S-1443~~ Drawings S-1838, Standard Waterproofing System for Deck and Abutments - Sheet 1, S-1839, Standard Waterproofing System for Deck and Abutments - Sheet 2, S-1840, Standard Waterproofing System for Deck and Abutments - Sheet 3.

## 16.2 ~~16.2~~ Material

### 16.2.1 ~~16.2.1~~ General

The materials supplied shall be able to withstand the heat generated during the waterproofing processes without affecting the performance of the material.

### 16.2.2 ~~16.2.2~~ Submittals

The Contractor shall submit documentation indicating specification compliance of his proposed materials to the Consultant for review and acceptance a minimum of ~~two~~ 2 weeks prior to the commencement of waterproofing installation operations.

### 16.2.3 ~~16.2.3~~ Sampling and Testing

The Contractor is advised that the Consultant may carry out additional material testing to confirm compliance.

If requested by the Consultant or the Department, the Contractor shall provide sufficient additional quantities of the asphalt membrane, rubber membrane, membrane reinforcing fabric, and/or protection board from the materials being used on the project. Requested samples and all associated costs will be considered incidental to the Work and no separate or additional payment will be made.

### 16.2.4 ~~16.2.4~~ Materials

#### Tack Coat

#### 16.2.4.1 The tack coat shall be aAsphaltic Primer

Asphaltic primer ~~type-meetings shall meet~~ the requirements of CAN/CGSB -37 -GP -9MA.

#### ~~16.2.4.1~~ 16.2.4.2 Asphalt Membrane

Asphalt membrane materials shall be supplied in cakes that are sealed and labeled by the manufacturer.

Material for the asphalt membrane shall ~~be hot applied rubberized asphalt meeting~~meet the requirements of the Ontario Ministry of Transportation's OPSS 1213 Specification.

#### ~~16.2.4.2~~16.2.4.3 Rubber Membrane

Rubber membrane shall consist of 1.2 mm thick butyl and ethylene propylene diene monomer (EPDM) rubber. The membrane shall meet the requirements of CAN/CGSB 37.52M.

#### ~~16.2.4.3~~16.2.4.4 Membrane Reinforcing Fabric

Membrane reinforcing fabric shall consist of spun bonded sheet structure composed of 100% continuous filament polyester fibres bonded together at their crossover points. The membrane shall be supplied in minimum widths of 300 mm.

#### ~~16.2.4.4~~16.2.4.5 Wick Drain

Wick drain shall consist of composite polypropylene with a total thickness of 3.6 mm, supplied in 100 mm widths. The puncture strength shall be a minimum of 45 N measured in accordance with ASTM D4833.

#### ~~16.2.4.5~~16.2.4.6 Waterproofing Protection Board

Waterproofing protection board shall consist of durable panels designed to provide a protective cushion between the hot mix asphaltic concrete pavement and the asphalt membrane.

The waterproofing protection board shall meet the requirements of the Ontario Ministry of Transportation's OPSS 1215 Specification for Protection Board.

### **16.3** ~~16.3~~—Equipment

An approved heating and mixing kettle shall be used to heat the ~~hot applied rubberized~~ asphalt membrane. The kettle shall be a double boiler oil transfer type with a built in agitator, and shall be equipped with permanently installed dial type thermometers with an accuracy of  $\pm 2$  °C to measure the temperature of the melted compound and oil. A separate calibrated thermometer with an accuracy of  $\pm 2$  °C shall be available on site to verify material temperatures.

The unit shall be capable of keeping the contents continuously agitated, free flowing and lump free until the material is drawn for application.

### **16.4** ~~16.4~~—Installation

#### 16.4.1 ~~16.4.1~~—General

The Contractor shall provide the Consultant with 48 hours advance notice prior to commencing any waterproofing operations.

Waterproofing operations shall only be carried out when the air and concrete surface temperatures are 5 °C or higher.

The Contractor shall carry out the operations involved in waterproofing in sequential order, and in such a manner that there are no delays between individual operations except those necessary to meet the requirements of these specifications.

Placement of the first asphalt concrete placement lift shall commence within 7 days of waterproofing installation or as determined by the Consultant based on anticipated exposure conditions.

#### 16.4.2 ~~16.4.2~~—Traffic Restriction

Once surface preparation operations have commenced the Contractor shall restrict all traffic other than the construction equipment directly associated with waterproofing and bridge paving operations from traveling over the prepared areas.

These restrictions shall remain in place until such time that the asphalt concrete pavement has been placed and cooled to ambient temperature.

#### 16.4.3 ~~16.4.3~~—Surface Preparation

##### 16.4.3.1 ~~16.4.3.1~~—Grout Tubes

Grout tubes shall be cut flush with the concrete deck surface prior to surface preparation. If grout tubes project above the concrete after surface preparation, they shall be re-cut flush with the concrete deck surface. A 450 mm by 450 mm piece of membrane reinforcing fabric, centered on the tube, shall be installed as described in ~~Section 16.4.5, Waterproofing of Joints and Cracks.~~Subsection 16.4.5, Waterproofing of Joints and Cracks.

##### 16.4.3.2 ~~16.4.3.2~~—New Bridge Construction

Concrete surfaces to receive waterproofing shall be cured a minimum of 14 days and then allowed to dry a minimum of 3 days. Concrete surfaces shall be completely dry prior to commencing waterproofing operations. Drying of concrete surfaces by the use of torches or other means that, in the opinion of the Consultant, may be potentially harmful will not be permitted.

Once the concrete surfaces are completely dry, they shall be prepared for waterproofing installation by sandblasting or shotblasting to expose sound, laitance free concrete for the entire installation area. All dirt and debris shall be removed and disposed of leaving a prepared surface satisfactory for ~~tack coating~~asphaltic primer.

##### 16.4.3.3 ~~16.4.3.3~~—Bridge Rehabilitation

Concrete surfaces to receive waterproofing shall be ground, scabbled, or bush hammered to achieve a surface texture of 3 mm or less prior to sandblasting or shotblasting. Concrete surfaces shall also meet the requirements of ~~Section 16.4.3.2, New Bridge Construction.~~Subsection 16.4.3.2, New Bridge Construction, prior to waterproofing installation.

New concrete overlays or concrete patches that are to receive waterproofing shall be cured for a minimum of 7 days unless otherwise specified and allowed to dry a minimum of 3 days.

#### ~~16.4.4 Tack Coating~~

#### ~~16.4.4 Tack coat~~ Application of Asphaltic Primer

Asphaltic primer shall be applied wherever waterproofing membrane is required. ~~Tack coating~~ Asphaltic primer and waterproofing installation shall not commence until the Consultant has inspected and accepted the surface preparation work.

~~Immediately prior to the application of the tack coat~~ All concrete surfaces shall have less than 6% moisture prior to application of the asphaltic primer. Testing shall be completed by the Contractor using a Hygrometer or Protimeter and the results reviewed and accepted by the Consultant.

~~After concrete moisture conditions have been determined acceptable by the Consultant and immediately prior to the application of the asphaltic primer,~~ the concrete surface shall be blown clean with oil and water free compressed air to remove all dust and other foreign material. The ~~tack coat~~ asphaltic primer shall be cut back with an equal volume of gasoline type solvent or an alternative cut back asphalt product compatible with the asphalt membrane.

The ~~tack coat~~ asphaltic primer application shall be such that the ~~tack material~~ asphaltic primer will be absorbed into the concrete, resulting in a surface that is dull and black in appearance. Excess application of ~~tack coat~~ asphaltic primer, indicated by a shiny black surface, shall be avoided. ~~Tack coat material~~ Asphaltic primer shall be applied at an approximate rate of 0.25  $\text{t/m}^2$ .

Waterproofing equipment or material shall not be permitted on the ~~tack coat~~ asphaltic primer until it has fully cured and is completely tack free.

#### ~~16.4.4~~ 16.4.5 ~~16.4.5~~ Waterproofing of Joints and Cracks

The Contractor shall pay particular attention to waterproofing installation over construction joints, lift hook pockets, grout tubes, patches and cracks.

After ~~tack coat~~ asphaltic primer application and prior to application of the primary hot asphalt membrane, a coat of hot asphalt membrane 3 mm to 4 mm thick and wide enough to extend 200 mm on either side of each joint or crack shall be applied in accordance with ~~Section 16.4.6, Application of Asphalt Membrane.~~ Subsection 16.4.6, Application of Asphalt Membrane. A strip of membrane reinforcing fabric material wide enough to extend 150 mm on ~~either side~~ both sides of the construction joint, lift hook pocket, grout tubes, patch or crack shall be applied while the asphalt membrane is still hot and tacky. The membrane reinforcing fabric shall then be covered with an additional layer of water proofing 2 mm to 3 mm thick. Membrane reinforcing fabric shall be overlapped for a minimum of 100 mm when multiple strips are used.

For areas along curbs, barrier walls, and deck drains, the ~~hot~~-asphalt membrane shall be applied to the height of the top of the hot mix ACP surface course and 150 mm onto the deck. Rubber membrane shall be applied into the first coat of asphalt membrane while it is still hot and tacky. The rubber membrane shall extend 50 mm up the vertical face and 100 mm onto the deck surface. Rubber membrane shall be overlapped for a minimum of 100 mm where multiple strips are used. A second coat of asphalt membrane shall then be applied to fully cover the rubber membrane.

#### ~~16.4.5~~16.4.6 ~~16.4.6~~ Application of Asphalt Membrane

Cakes of asphalt membrane shall be melted in the heating and mixing kettle to a temperature not exceeding that recommended by the membrane Manufacturer.

The asphalt membrane shall not be applied until the ~~tack-coat~~asphaltic primer has cured completely.

The application temperature of asphalt membrane shall be within the range recommended by the Manufacturer. The membrane shall be applied in a uniform film having a minimum thickness of 4 mm and a maximum thickness of 6 mm.

Application of the asphalt membrane shall be carried out in a continuous manner to the extent practicable. Where joints are unavoidable, they shall be overlapped by a minimum of 150 mm. The membrane shall be applied over all waterproofed joints and cracks, and shall extend up the face of curbs, barrier walls, and deck drains, to the height of the top of the design hot mix asphalt surface course.

The Contractor shall conduct his operations in such a manner that plugging of deck drains and/or drainage tubes is avoided. Plugged deck drains or drainage tubes shall be cleaned out by the Contractor at his expense.

#### ~~16.4.6~~16.4.7 ~~16.4.7~~ Wick Drain Installation

Wick drains shall be installed along the full lengths of the gutters, and shall be installed when the asphalt membrane is still hot and tacky. Special attention shall be given to waterproofing and wick drain modifications at deck drain pipe locations. ~~Tack-coat~~Asphaltic primer shall not be applied to wick drains.

#### ~~16.4.7~~16.4.8 ~~16.4.8~~ Protection Board Installation

The Contractor shall ensure that the asphalt membrane thickness meets the specified requirements prior to placing the protection board. Protection boards shall be laid on the asphalt membrane while the membrane is still hot, with the length of the board running transversely on the deck. The protection boards shall be placed with edges overlapping a minimum 12 mm and a maximum of 25 mm, both longitudinally and transversely. The protection board edge shall be within 5 mm of all wick drains, vertical faces of drains, and vertical faces of expansion joints.

Protection board shall be lapped to produce a shingling effect in both the longitudinal and transverse directions. Protection boards shall be placed such that the longitudinal (direction of traffic flow) joints are staggered a minimum of 150 mm. Boards shall be rolled using a linoleum or lawn type roller while the membrane is still warm to ensure good contact with the membrane. Holes shall be cut through the protection board to allow water to drain freely through the drainage tubes. At locations where the edges of the protection board have curled-up, the curled-up edges shall be cemented down using hot membrane material to the satisfaction of the Consultant.

Protection boards that are warped, distorted, or damaged in any way, whether by manufacture, storage, handling or exposure to the elements shall be replaced with new material.

### 16.5 ~~16.5~~—Measurement and Payment

Measurement for payment of ~~deck~~-waterproofing will be by the square metre, measured to the nearest 0.1 m<sup>2</sup>.

The quantity to be paid for will be based on horizontal measurement of surface areas where waterproofing has been acceptably installed. Vertical faces will not be measured.

Payment for waterproofing will be made at the unit price bid for “~~Deck~~-Waterproofing”, and will be full compensation for traffic control; the preparation of ~~the~~-concrete ~~deck-surfaces~~surfaces, including sandblasting and/or shotblasting; the supply and application of the ~~tack-coat~~asphaltic primer; the supply and installation of asphalt membrane, membrane reinforcing fabric, rubber membrane, wick drain, and protection board; ~~and~~including all labour, equipment, tools and incidentals necessary to complete the Work as shown on the Drawings and to the satisfaction of the Consultant.

All costs associated with waterproofing of vertical faces of curbs and barriers will be considered incidental to the Work, and no separate or additional payment will be made.



# STANDARD SPECIFICATIONS FOR BRIDGE CONSTRUCTION

## SECTION 17 ASPHALT CONCRETE PAVEMENT

### TABLE OF CONTENTS

<b>17.1</b>	<b>General</b> .....	<b>17-1</b>
<b>17.2</b>	<b>Materials</b> .....	<b>17-2</b>
<b>17.3</b>	<b>Asphalt Mix Design and Job Mix Formula</b> .....	<b>17-2</b>
<b>17.4</b>	<b>Sampling and Testing</b> .....	<b>17-3</b>
	17.4.1 Quality Control Testing.....	17-4
<b>17.5</b>	<b>Equipment and Methods</b> .....	<b>17-7</b>
	17.5.1 General.....	17-7
	17.5.2 Asphalt Mixing Plants.....	17-7
	17.5.3 Transportation of ACP.....	17-7
	17.5.4 Pavers.....	17-7
	17.5.5 Compaction.....	17-8
<b>17.6</b>	<b>Construction</b> .....	<b>17-9</b>
	17.6.1 ACP Joints.....	17-10
	17.6.2 Protection of the Environment and Bridge Components.....	17-11
	17.6.3 Mix Production.....	17-12
	17.6.4 Tack Coat.....	17-12
	17.6.5 Spreading and Compaction.....	17-13
	17.6.5.1 General.....	17-13
	17.6.5.2 Spreading.....	17-13
	17.6.5.3 Compaction.....	17-13
	17.6.5.4 Hot-Applied Rubberized Asphalt Waterproofing Membrane System ACP.....	17-15
	17.6.5.5 Polymer Waterproofing Membrane Systems ACP.....	17-15
	17.6.5.6 Approach Road Transition ACP.....	17-16
	17.6.5.7 Coring.....	17-16
	17.6.6 Surface Requirements and Material Tolerances.....	17-17
	17.6.6.1 Smoothness.....	17-17
	17.6.6.2 Segregation.....	17-17
	17.6.6.3 Defects.....	17-18
	17.6.6.4 Asphalt Content.....	17-19
	17.6.6.5 Aggregate Gradation.....	17-19
	17.6.7 Repair Procedures.....	17-20
	17.6.8 ACP Surface Removal.....	17-20
	17.6.9 ACP Gradeline Profiling.....	17-20
<b>17.7</b>	<b>Measurement and Payment</b> .....	<b>17-21</b>
	17.7.1 Payment by Lump Sum.....	17-21
	17.7.2 Payment by Unit Price.....	17-21
	17.7.3 Payment Adjustment for Density.....	17-22



## 17.1 General

Asphalt Concrete Pavement (ACP) shall ~~consist of crushed aggregates with reclaimed asphalt pavement (RAP), blend sand and filler material as required, and asphalt cement, combined in a hot mix plant as hereinafter specified~~ be mixed, placed, and compacted ~~on bridges and approaches in conformity with to~~ the lines, grades, dimensions and cross -section as ~~provided and as~~ shown on the Drawings:

~~and in accordance with these specifications.~~ This specification ~~is for the following applications~~ applies to:

- ~~————~~ ACP Wearing Surface applied over hot applied rubberized asphalt membrane on bridge deck waterproofing complete with protection board described in Section 16, Waterproofing;
- ~~————~~ ACP Wearing Surface applied ACP on polymer ~~membrane~~ waterproofing membranes; and
- ~~————~~ Asphalt Concrete Pavement transition and ACP on approach road paving transitions.

For projects where transition ACP is required, ~~the~~ The Contractor shall ~~cold mill to achieve a 40 mm~~ submit an ACP Mixing and Placement Plan for each bridge and associated approach transition for the Consultant's review and acceptance a minimum thickness of 2 weeks prior to commencement of ACP paving operations. ~~The joint between the existing ACP~~ ACP Mixing and the new transition ACP Placement Plan shall be saw cut a minimum include but not be limited to the following:

- Surface removal plan (if applicable);
- Source location of 40 mm across the full width ACP;
- Asphalt mixing plant Certificate of roadway. ~~————~~ Milling shall be considered as part of Calibration;
- Asphalt mix design and job mix formula;
- Asphalt Concrete Pavement and no separate or additional payment mixing plant production rate, haul route and distance, number of haul trucks and load size, paver production capacity;
- Placing, spreading and compaction temperature range(s);
- Direction of ACP placement (bridges with waterproofing protection board);
- Details of placement and compaction equipment;

- Quality control and testing plan including but not limited to material testing, details of control strip method (drawing outlining control density test locations and mat density test locations), and QC personnel;
- Details of environmental protection measures;
- Details of bridge component protection measures for barriers/curbs/medians, deck joint concrete blockouts, paving lips, and wick drains;
- Details of ACP longitudinal and transverse (if applicable) joint locations;
- Details of saw cut joint protection measures; and
- Schedule.

After the ACP Mixing and Placement Plan has been reviewed and accepted by the Consultant a preconstruction meeting shall occur prior to any operations. The Contractor's project manager, paving superintendent and foreman that will be made complete the Work shall attend the preconstruction meeting.

This specification shall be used in conjunction with the Standard Specifications for Highway Construction. In areas of conflict between this specification and the Standard Specifications for Highway Construction, this specification shall govern.

## **17.2 ~~17.2~~—Materials**

The Contractor shall supply Asphalt Cement and Aggregate in accordance with sections Subsection 3.50.2.1, ~~Asphalt~~, and Subsection 3.50.2.2, ~~Aggregate~~, of the Standard Specifications for Highway Construction.

The Tack coat shall be SS 1 liquid asphalt shall be applied as a tack coat to ensure a bond between the surface being paved and the subsequent course, and shall consist of SS-1 or RC 30/70. When SS-1 is used it shall be diluted 50:50 with an equal volume of clean potable water. In all cases where RC 30/70 may be considered an alternative tack coat to SS-1 when adverse weather conditions permit, SS-1 shall be used in preference to RC 30/70. They require its usage and determined acceptable by the Consultant. Tack coat materials shall conform to the Specifications listed in Tables ASPH6 and ASPH7 of Specification 5.7 of the Standard Specifications for Highway Construction.

17.3—A chemical warm mix asphalt additive from the Department's Products List may be used in the ACP mix when haul routes are greater than one hour.

## **17.3 Asphalt Mix Design and Job Mix Formula**

The Contractor shall prepare and submit asphalt mix designs in accordance with section Subsection 3.50.3, Asphalt Mix Design and Job Mix Formula, of the Standard Specifications for Highway Construction that are is representative of materials to be used.

~~For asphalt mix designs which were completed in excess of six months prior to anticipated production, additional analysis of more recent sampling shall be provided, as required to confirm that the mix ingredients continue to meet requirements. The Type of Asphalt Mix to be used shall be as specified. Generally bridges located on Highways Provincial highways with a service classification designation 1 -216-a or 2 the asphalt mix shall be Type H2 Asphalt Mix using with PG 58-28 asphalt cement grade will be specified, and.~~

~~For bridges located on Highways 500 – 986 and local roads Provincial highways with a service classification designation 3 or 4 the asphalt mix shall be Type M1 Asphalt Mix using a with PG 52-34 asphalt cement grade will be specified.~~

~~When accepted by Any proposed modifications to asphalt cement grades shall be submitted to the Consultant and the Contractor will be permitted to supply a Type H2 Department for review and acceptance with the Asphalt Mix where a Type M1 Asphalt Design and Job Mix has been specified Formula submission.~~

#### 17.4 ~~17.4~~ Sampling and Testing

Sampling and testing procedures used to determine material characteristics shall be as outlined in the Subsection 3.50.4, Sampling and Testing, of the Standard Specifications for Highway Construction ~~section 3.50.4 Sampling and Testing~~ unless specified otherwise ~~specified~~.

In addition to quality control testing completed by the Contractor described in Section 17.5, Subsection 17.4.1, Quality Control Testing, quality assurance (QA) testing will be completed by the Consultant. QA testing will be completed on two 6 kg samples per lift (ATT-37) to determine the uncorrected asphalt content and aggregate gradation: (ATT-26). The Consultant will use the Contractor's measured correction factor to establish the actual asphalt content. The actual asphalt content will be determined by test method ATT-12 or ATT-74, and includes the correction factor for asphalt binder lost due to absorption by the aggregate or aggregate loss. An inspection to identify any areas of segregation will be completed by the Consultant.

~~In-place density testing may be carried out on an as required basis at locations determined by the Consultant.~~

The Consultant shall have access to the Work at all times for taking samples. The Contractor shall provide any assistance necessary for taking samples and shall reinstate pavement lifts or other structures to the satisfaction of the Consultant at the ~~positions~~locations where samples have been taken. Compensation for providing assistance with sampling and for reinstatement where samples are taken ~~shall will be included in considered incidental to the unit price bid for the various items of Work tested~~ and no separate or additional payment will be made.

The Consultant's review and/or acceptance of any materials or mixtures shall in no way relieve the Contractor from his obligation to provide materials, mixtures and workmanship in accordance with the specifications.

17.4.1 ~~17.5~~ Quality Control Testing

Quality control testing shall be completed on ~~all projects with Contracts that include more than 50 tonnes of ACP or more and in accordance with Table 17-1: Quality Control Testing Requirements.~~ The Contractor shall be responsible for ~~the coordination of~~ all quality control testing and ~~the~~ associated costs. ~~All testing shall be completed by an independent third party testing agency that is prequalified by the Department in the category of QA Testing Services (Grading, Base Paving).~~ Results of all quality control tests shall be submitted to the Consultant within 7 days of the test being completed.

~~The Contractor shall produce crushed aggregates in accordance with Specification 3.2, Aggregate Production and Stockpiling for Designation 1 aggregate and requirements listed in section 3.50.3.2 Design Requirements.~~

~~Unless otherwise specified, the latest edition of the following standard Alberta Transportation test methods (ATT) will be used to determine material characteristics. Test methods and minimum frequencies of testing are shown in Table 17.5-1: Quality Control Testing Requirements.~~

Table 17.5

## Quality Control Testing Requirements

TEST	TEST METHOD	MINIMUM FREQUENCY	
Aggregate Production		<del>See Specification 3.2</del> As specified in the Standard Specifications for Highway Construction Subsection 3.2	
<b>ASPHALT MIX PLANT</b>			
1. <del>Asphalt Mix Plant Calibration</del>	ATT-17	Once per <del>project</del> calendar year or as requested by the Consultant	
2. <del>Inspection</del> Sample Testing		ATT-16	Minimum of one per lift.
<b>SAMPLES</b>			
1. <del>Asphalt Cement</del>	ATT-42	As requested by the Consultant	
1. <del>2.</del> Tack, Prime and Fog Materials	ATT-42	As <del>requested</del> determined by the Consultant	
3. <del>Cold Feed Aggregate</del>	ATT-38	(3)	
4. <del>Mix</del>	ATT-37	Minimum of one per lift	

Section 17, Asphalt Concrete Pavement

2. <del>5. QA Cores – Stratified Random Test Sites Chosen By The Consultant (Coring done by Contractor) Temperatures</del>	ATT- <del>56</del> <u>30</u>	As requested by the Consultant <u>As specified in Subsection 17.6.5</u>
3. <del>—i) QA Cores for Pavement Compaction Monitoring by Nuclear Density Gauge</del>	ATT- <del>511</del>	As requested by the Consultant <u>As specified in Subsection 17.6.5</u>
4. <del>—ii) QA Cores for Asphalt Content and Gradation Cement</del>	ATT- <del>542</del>	As <del>requested</del> <u>determined</u> by the Consultant
<b>ADDITIONAL TESTING REQUIREMENTS</b>		
1. <del>Sieve Analysis Crushed Aggregate</del>	ATT- <del>26</del>	Minimum of one test for each aggregate component.

<b>ADDITIONAL TESTING REQUIREMENTS</b>		
<del>2. Percent Fracture of Crushed Aggregate</del>	<del>ATT-5037</del>	Minimum of one <del>test for each aggregate component per lift</del>
5. <u>Mix</u>		
6. <del>3.</del> Mix Asphalt Content	AASHTO T-164, T287 or ATT-12 or ATT-74	Minimum of one per lift-
7. <del>4.</del> Correction Factors	ATT-12, Part III or ATT-74, Part II	Once <del>for each</del> per mix design-
8. <del>5.</del> Mix Moisture Content	ATT-15	Minimum of one per lift-
9. <del>6.</del> Aggregate Sieve Analysis ( <u>any combination of cold feed, extraction or ignition</u> )	ATT-26	<u>Minimum of one per lift</u> (3)
<u>10. Marshall Briquettes</u>	<u>ATT-13</u>	<u>Minimum of one per lift</u>
<u>11. Void Calculations, Cores or Formed Specimens</u>	<u>ATT-36</u>	<u>Minimum of one per lift</u>
<del>10.12.</del> <del>7.</del> Pavement Segregation	Paving Guidelines and Segregation Rating Manual	<del>(4)</del> <u>As specified in Subsection 17.6.6.2, Segregation</u>
<u>Coring</u> <del>8. Field Formed Marshall Briquettes</del>		<del>ATT-13</del> <del>(1)</del>
<del>11.13.</del> <del>9.</del> <u>Coring Density Immersion Method, Saturated Surface Dry</u>	<del>ATT-75</del>	<del>(2)</del> <u>As specified by the Consultant and in accordance with 17.6.5</u>
<del>10. Void Calculations, Cores or Formed Specimens</del>	<del>ATT-36</del>	<del>(1)</del>
<del>11. Temperatures</del>	<del>ATT-30</del>	<del>(1)</del>
i. <del>12.</del> <u>ACP Density – Percent Compaction, Cores, or Nuclear Density</u>	ATT-67, ATT-5 or ATT-14	<del>(2)</del> <u>As determined by the Consultant</u>
<del>13. Correction Factors, Nuclear Moisture – Density Measurement</del>	<del>ATT-48</del>	<del>(2)</del>
ii. <u>Density Immersion Method, Saturated Surface Dry</u> <del>14. Pavement Smoothness</del>	<del>ATT-597</del>	As <del>requested</del> <u>determined</u> by the Consultant



~~Notes: (1) Minimum frequency not specified.~~

~~(2) Nuclear Density Testing is required on all projects. The Consultant may require the Contractor to obtain pavement cores (top lift only) for QC testing.~~

~~(3) One sieve analysis of the combined aggregate (any combination of cold feed, extraction or ignition) is required per lift.~~

~~(4) At the end of paving each day or completion of a paving lift, the Consultant will perform an inspection of the paving to identify any areas of pavement segregation.~~

## 17.5 ~~17.6~~ Equipment and Methods

### 17.5.1 ~~17.6.1~~ General

Equipment and methods used ~~on this work~~ shall be adequate to ~~produce and place the material as specified herein, and shall be subject to the acceptance of the Consultant. The Department reserves the right to order changes or the discontinuance of use of~~ meet all specification requirements. Any equipment or method which, in the opinion of the Consultant, ~~fails to produce satisfactory results~~ contributes to work that does not meet specification requirements shall be immediately corrected by the Contractor to the full satisfaction of the Consultant.

### 17.5.2 ~~17.6.2~~ Asphalt Mixing ~~Plant Requirements~~ Plants

All Asphalt mixing plants ~~used by the Contractor for the preparation of asphalt concrete material~~ shall be used in the production of ACP and conform to the requirements of ~~section~~ Subsection 3.50.5.1.2, Mixing Plant, of the Standard Specifications for Highway Construction. The Contractor shall provide the Consultant with a certificate of calibration which certifies that the plant has been calibrated to produce a uniform mixture in accordance with the Job Mix Formula.

### 17.5.3 ~~17.6.3~~ Equipment for Transportation of ~~Mixture~~ ACP

~~The mixture~~ ACP shall be transported from the asphalt mixing plant directly to the worksite paver hopper in end-dump trucks with smooth metal boxes ~~in good and leak proof condition, previously capable of fully containing all materials until discharge. End-dump truck boxes shall be thoroughly~~ cleaned of hardened ACP and all other foreign materials ~~or hardened prior to being loaded at the~~ asphalt concrete mixture mixing plant. Each ~~vehicle~~ end-dump truck shall be equipped with a tarpaulin of suitable material and of sufficient size to overhang the vehicle box when fully loaded. ~~Tarpaulins shall be on the haul unit at all times and shall be used to cover the mixture completely unless otherwise determined by the Consultant.~~ Tarpaulins shall be securely fastened on all sides of the ~~box~~ truck box and only be removed immediately prior to discharging ACP into the paver hopper.

Excess truck box lubricants such as detergent or lime solutions shall not ~~be allowed to~~ contaminate the mix. Petroleum based truck box lubricants shall not be used.

### ~~17.6.4~~ Paver

#### 17.5.4 Pavers

Pavers shall be ~~acceptable to the Consultant and be~~ self-propelled and, configured to receive ACP directly into a hopper from end-dump trucks, operated to maintain required ~~levels~~profiles, cross-falls and joint matching. For new construction, bridge structures that have more than 3 travel lanes or longer than 75 m in length shall be paved with two or more pavers operating in simultaneous echelon such that the entire width of the ACP lift is completed at one time.

#### ~~17.5.4~~17.5.5 ~~17.6.5~~ Compaction Equipment

The Contractor shall provide sufficient self-propelled equipment to obtain the ~~required~~specified degree of compaction ~~of the asphalt concrete mixture. The compaction capability of the equipment used shall equal or exceed the placing rate of the spreading operations and shall be capable of obtaining the required compaction before the temperature of the mat falls below specified levels.~~ Compaction equipment shall be of a suitable size, weight and type as acceptable to the Consultant, such that displacement of the mat and/or disruption of underlying materials ~~does not occur. do not occur. The compaction capability of the equipment used shall equal or exceed the placing rate.~~

Compaction equipment shall be in proper mechanical condition and operated such that uniform and complete compaction is obtained throughout the entire width, depth and length of the ~~pavement~~ACP being constructed. Rollers ~~shall be configured to ensure uniform and complete compaction up to the face of barriers, curbs and medians. Rollers provided~~ shall leave a smooth, properly finished surface, true to grade and cross-section without ruts or other irregularities. All compaction equipment shall be equipped with methods of wetting the tires or drums to prevent adhesion or pickup of ~~the asphalt mixture~~ACP.

At a minimum, the Contractor shall provide ~~as a minimum of the following equipment for ACP compaction operations:~~

- One rubber tired roller and (mass greater than 10 tonnes);
- One smooth steel drum type roller. The rollers shall have a minimum 10 tonnes mass. Vibrators on vibratory rollers shall not be activated. (mass greater than 10 tonnes);
- One compact tandem articulating smooth steel drum type roller (mass of 1 to 2 tonnes);  
and

Specialized equipment ~~may be required~~ to achieve adequate compaction and smoothness in tight corners at ~~expansion assemblies and~~ deck joints.

### 17.7 Construction

#### 17.7.1 Asphalt Temperatures

~~The asphalt tank supplying the plant mixer shall be equipped with heating apparatus capable of producing asphalt temperatures up to but not greater than 155°C uniformly throughout the entire contents of the tank. The Contractor shall maintain the asphalt temperature within plus or minus 10°C of the specified mixing temperature.~~

~~17.7.2—Mix Production~~

~~The Contractor shall produce an asphalt mixture in accordance with section 3.50.5.1.3 Mix Production of the Standard Specifications for Highway Construction.~~

~~17.7.3—Protection of Adjacent Bridge Components~~

~~The Contractor shall protect all bridge components to prevent splatter or staining from asphaltic materials.~~

- ~~• 17.7.4— or other locations.~~

~~The compact tandem articulating roller shall be configured with a single arm full flush drum between 0.7 and 1 m in width and be solely dedicated to compacting ACP within 12 mm of barriers, curbs, deck joints and medians. The Department and the Consultant, at their sole discretion, will determine equivalency of proposed alternate roller equipment.~~

~~Vibrators on vibratory rollers shall not be activated on bridge decks, roof and approach slabs, or any structural element within 1 m of the bridge.~~

~~Tack Coat~~

~~Asphalt tack coat shall be applied to the existing protection board, polymer membrane waterproofing, granular base course, or existing asphalt concrete substrate and between lifts of asphalt concrete pavement, at the locations and to the dimensions designated by the Consultant.~~

~~Tack coat shall not be applied to wick drains.~~

~~The surface to be tacked shall be dry and free of loose or deleterious material when the tack is applied.~~

~~The asphalt tack coat shall be applied in a uniform manner at an application rate of 0.5 l/m<sup>2</sup> and asphalt temperature designated by the Consultant. The ambient air temperature at the time of application shall be 5°C or higher.~~

~~On areas where the Contractor is required to accommodate traffic, the surface shall be tacked in two operations. In the first operation one half of the width shall be tacked with the remaining half being tacked after the first half has cured.~~

~~The tack coat shall be protected from traffic or other damage. Areas on which the tack has been damaged by traffic shall be retacked at the Contractor's expense.~~

~~17.7.5—Spreading and Compaction~~

~~17.7.5.1—General~~

~~The mixture shall be placed only upon a dry, frost free substrate on which the tack coat has cured and when the ambient air temperature is 5°C or higher. Prior to the delivery of the mixture on the work, the base shall be cleaned of all loose or foreign material. The mixture shall be spread and compacted during daylight hours only, unless artificial light satisfactory to the Consultant is provided.~~

~~During spreading and compaction operations, Care shall be taken at all times to ensure that:~~

- ~~— Asphalt mixture is not wasted over the side or onto the adjacent surface mat.~~
- ~~— Damage is not done to the waterproofing membrane, curbs, barriers, medians, concrete paving lips, manholes, or drains.~~
- ~~— Damage is not done to guide posts, guardrails, signs, power conduits or any other roadside installations.~~

~~The Contractor shall make immediate and adequate repair of any damage resulting from his operations at his own expense.~~

#### ~~17.7.5.2 Spreading~~

~~The mix shall be spread at a temperature sufficient for the specified compaction and finishing at the final placement area.~~

~~The manner of placing shall be as acceptable to the Consultant to ensure safe accommodation of traffic, quality control and drainage. The longitudinal and transverse edges of each lane shall be straight in alignment, uniform, and of the same thickness as the adjoining pavement layer. Adequate measures for the protection of the exposed edges shall be maintained throughout the work.~~

~~Each layer shall be placed, finished and compacted for the full width, and then allowed to cool down to 50°C or colder prior to commencing the subsequent layer.~~

~~In the placing of successive lifts, the individual mixture spreads shall be aligned in a manner such that the longitudinal joints in successive lifts do not coincide. Unless otherwise directed, the lateral distance between the longitudinal joints in the successive lifts shall be not less than 0.30 m. The longitudinal joint of the final lift of asphalt concrete pavement shall not be located within the wheel path areas.~~

~~The surface of all lifts should not exhibit evidence of segregation.~~

## **17.6 Construction**

### **17.6.1 ACP Joints**

All longitudinal and transverse joints shall be of the vertical butt joint type, made in a careful manner, well bonded and sealed, and shall be finished to provide a continuous, smooth profile across the joints.

~~17.7.5.3 — Longitudinal joints of successive ACP mats shall be offset a minimum of 0.3 m, unless otherwise accepted by the Consultant. Longitudinal joints of final lift ACP shall not be located within wheel path areas.~~

~~For transition and/or approach road paving, the Contractor shall saw cut construction joints between existing ACP and new ACP. The construction joint shall be saw cut to a depth of the new ACP and on a 15° left hand forward (LHF) skew to the centreline of the roadway for the full width of the roadway. The construction joint shall be protected to prevent spalling, raveling or other damage. Joints that are damaged shall be re-saw cut at the Contractor's expense.~~

#### ~~17.6.2 Protection of the Environment and Bridge Components~~

~~The Contractor shall implement temporary measures to ensure no asphaltic materials are released into the environment. All deck drains and drainage components shall be adequately sealed to prevent leakage.~~

~~The Contractor shall protect all bridge components from splatter or staining from asphaltic materials. If splatter or staining occurs it shall be repaired to the full satisfaction of the Consultant and at the Contractor's expense. Prior to completing repairs the Contractor shall submit a repair procedure to the Consultant for review and acceptance. In addition to removing the splatter or staining of bridge components the repair procedure shall include removing and reinstating all specified concrete finishes to the satisfaction of the Consultant.~~

~~The Contractor shall provide temporary protection to deck joint concrete paving lips such that haul trucks, pavers or and compaction~~ **Compaction**

~~The Contractor shall monitor the compaction process using a Control Strip Method. Control Strips are generally established on each mat placed.~~

~~The Control Strip lift shall be compacted using at least the following equipment:~~

- ~~(a) One steel roller weighing not less than 10 tonnes; and~~
- ~~(b) One self-propelled pneumatic rollers, ballasted to its maximum capacity, weighing access does not less than 10 tonnes.~~

~~Once the mix has been spread by the paver and the initial pass of the breakdown roller has been done, moisture and density measurements for determining the Control Density will commence at five locations within the Control Strip area, and will continue following repeated passes of the compaction equipment until the apparent maximum density is attained. These measurements shall be taken by the Contractor using nuclear testing equipment.~~

~~The Contractor shall compact the pavement to a minimum average density of 97% of Marshall Density, with no individual density less than 95%.~~

~~When the compaction methods and procedures, in the opinion of the Consultant are not achieving the desired compaction specifications, the Consultant may require the Contractor, at any time to obtain cores of the top lift pavement. The number of cores will be determined by chip or spall the Consultant. The cores will be tested by concrete or damage the Contractor and the results provided to the Consultant as they become available.~~

~~Percent compaction will be expressed in percent of Marshall Standard Density. The Marshall Standard Density used for determining pavement compaction shall be as follows:~~

~~(a) Marshall Densities determined on field sampled mix, or if not available then;~~

~~(b) Marshall Design Density as reported in the approved mix design.~~

~~waterproofing~~ **Coring** shall be done using methods which will not damage the rubberized asphalt membrane or protection board. ~~Core holessystem or any other bridge component. Any damage caused by equipment accessing the bridge shall be completely de-watered and dried. A generous application of liquid asphalt shall be applied to the bottom and sides of the core hole and allowed to cure. Asphalt mix shall then be tamped in lifts into the core hole until flush with the surface of the surrounding pavement.~~

~~The immediately repaired by Contractor shall not undertake any coring unless approved by the to the satisfaction of the Consultant and the Department.~~

### 17.6.3 Mix Production

~~The Contractor shall be reimbursed produce ACP in accordance with Subsection 3.50.5.1.3, Mix Production, of the Standard Specifications for obtaining, preparing and testing cores at the rate of \$100 per core location Highway Construction.~~

~~In order to The Contractor shall maintain the ACP temperature within specified mixing temperature and under no circumstance shall it exceed 155 °C.~~

### 17.6.4 Tack Coat

~~After all temporary protection measures have been acceptably installed; tack coat shall be applied to all surfaces that receive ACP except bridge waterproofing wick drains. To prevent contamination, wick drains shall be covered with materials acceptable to the Consultant during application of the tack coat.~~

~~The surface to be tacked shall be dry and free of loose or deleterious material prior to the application of the tack coat.~~

~~Tack coat shall be applied in a uniform manner at an application rate of 0.5 l/m<sup>2</sup> and suitable temperature. The ambient air temperature at the time of application shall be 5 °C or higher.~~

~~The tack coat shall be protected from traffic or other damage. Damaged areas shall be retacked at the Contractor's expense to the full satisfaction of the Consultant.~~

### 17.6.5 Spreading and Compaction

#### 17.6.5.1 General

ACP shall only be placed on clean, dry, frost free substrate on which the tack coat has cured and when the ambient air temperature is 5 °C or higher. Prior to placement of ACP, all surfaces shall be cleaned of loose or foreign material.

ACP shall be spread and compacted during daylight hours.

Care shall be taken at all times to ensure that:

- ACP is not wasted over the side or onto the adjacent surface mat;
- Damage does not occur to the waterproofing membrane, curbs, barriers, medians, concrete paving lips, manholes, or drains;
- Damage does not occur to guide posts, guardrails, signs, power conduits or any other roadside appurtenances.

Any damage shall be repaired to the full satisfaction of the Consultant and at the Contractor's expense.

Each mat shall be spread, compacted, finished and allowed to cool down to 50 °C or less prior to placing subsequent lifts. Lifts of ACP shall not exceed 70 mm.

The crown of the bridge deck and approaches, shall be maintained and the Contractor shall avoid operating the compaction equipment on or across the crown. Compaction procedures and equipment shall be such that displacement of the mixture ACP does not occur. Roller wheels Compaction equipment shall be kept slightly moistened by sufficiently wet with water or oil to prevent picking up the mixture, but an excess of either water or oil will not be permitted ACP pickup.

#### 17.6.5.2 In cases where the asphaltic mixture is placed under weather and Spreading

The ACP mix shall be spread at a temperature conditions which may be considered less than ideal, the Contractor shall modify normal operations and provide special attentions sufficient to these situations such that achieve the specified compaction temperatures.

The manner of placing shall ensure safe accommodation of traffic, quality control and drainage. The longitudinal and transverse edges of each mat shall be straight in alignment, uniform, and of the same thickness as the adjoining pavement mat. Measures shall be implemented to protect exposed edges throughout the Work.

#### 17.6.5.3 Compaction results are

ACP compaction shall be measured and monitored using the control strip method.

For each bridge structure, a control strip density shall be determined for each lift of ACP. The control strip density shall be determined on the first mat placed of each lift as follows:

- Control strip test locations shall be located every 20 m along length of the bridge. No test location shall be located within 200 mm of any curb, barrier, median, or mat edge.
- Once the ACP has been spread by the paver and the initial pass of the breakdown roller has been made, the control strip test locations shall be marked out on the ACP surface by outlining the nuclear density gauge using chalk:
- At each of the control strip test locations a nuclear density reading shall be taken following each pass of compaction equipment. Compaction shall continue until no further increase in density is achieved. The maximum density reading from each of the control strip test locations will be averaged to determine the Control Strip Density ( $\text{kg/m}^3$ ) of the lift.

17.7.5.4 — After the Control Strip Density has been determined, compaction testing for all remaining mats of the lift shall be as follows:

- Each mat shall be monitored and continuously tested for compaction using the nuclear density gauge; and
- Following compaction, density readings shall be taken and recorded at a minimum frequency of one per every 10 m of bridge length or 20 m of approach road transitions for each mat placed (minimum 2 tests per mat). The average of the readings taken by the nuclear gauge shall be considered the Average Mat Density. Density results shall be provided to the Consultant on the same day of testing.

All compaction testing shall be completed by an independent third party testing agency that is prequalified by the Department in the category of QA Testing Services (Grading, Base Paving). The testing agency shall maintain a minimum of two nuclear density gauges on site during compaction operations. Only one nuclear density gauge shall be utilized for each paving day and the other stored as a backup. Both nuclear density gauges shall be in good working order and their condition and calibration verified by the Contractor prior to commencement of any ACP placement. Verification of nuclear density gauge calibration shall immediately be provided to the Consultant upon request.

The minimum average density of each mat shall be 98% of the control density. If the minimum average mat density is less than 98%, but greater than 95% of the control density, the mat, at the sole discretion of the Department and Consultant, may be accepted at an adjusted price in accordance with Subsection 17.7.3, Payment Adjustment for Density.

Rejected ACP shall be removed and replaced by the Contractor at his expense to the full satisfaction of the Consultant. The Contractor shall submit a removal and replacement procedure to the Consultant for review and acceptance before the commencement of any removal.



~~17.5.4.1~~ ~~17.6.5.4~~ Hot-Applied Rubberized Asphalt Waterproofing Membrane System  
Paving ACP

~~The ACP wearing surface. The following specific requirements are in addition to those stated elsewhere within this specification.~~

~~ACP shall be placed and compacted in two nominal 40 mm lifts. The first lift of ACP shall be spread by the asphalt paver in the direction of the protection board laps (downhill). In the event that paving cannot be carried out in the direction of the protection board laps, the Contractor shall submit a procedure to the Consultant for review, and acceptance identifying all measures that will be taken to ensure that the protection board and waterproofing membrane will not be damaged during paving. To avoid damaging the waterproofing membrane the paver shall not exceed the placing rate or push the delivery trucks, all equipment shall perform all turning movements off the bridge deck, and the asphalt mixture shall not be dumped onto the protection board ahead of the paver operations.~~

~~The paver shall not push the delivery end-dump trucks. All equipment shall perform all turning movements off the bridge. ACP shall be dumped directly into the paver hopper. Under no circumstance shall ACP be placed onto the protection board ahead of the paver or at other locations.~~

The allowable ACP temperature range ~~for at the start of~~ compaction of ACP lifts on the hot-rubberized asphalt waterproofing membrane system shall be ~~as follows:~~ in accordance with Table 17-2: Allowable Compaction Temperatures for Hot-Applied Rubberized Asphalt Waterproofing Membrane ACP.

**Table 17-2: Allowable Compaction Temperatures for Hot-Applied Rubberized Asphalt Waterproofing Membrane ACP**

ASPHALT GRADE	COMPACTION TEMPERATURE RANGE	
	FIRST LIFT	SECOND LIFT
<del>150 - 200 (A) or PG58-28</del>	<del>MAX: 95°C - 105°C</del>	<del>128°C - 138°C</del>
<del>200 - 300 (A) or PG52-34</del>	<del>MAX: 95°C - 105°C</del>	<del>123°C - 133°C</del>

~~The minimum average Marshall density of the first lift shall be 95% with no individual test less than 93%. The remainder of the first lift shall have a minimum Marshall density of the 95%. The minimum average Marshall density of the second lift shall be 97% with no individual density less than 95%.~~

~~17.5.4.2~~ ~~17.6.5.5~~ ~~17.7.5.5~~ Polymer Waterproofing Membrane Paving Systems ACP

~~The following specific requirements are in addition to those stated elsewhere within this specification.~~

The ACP wearing surface shall be placed and compacted in one ~~lift of 50 mm~~ nominal 50 mm thickness. ~~Dumping of or as specified in the asphalt mixture~~ Contract documents.

The paver shall not push the delivery end-dump trucks. All equipment shall perform all turning movements off the bridge. ACP shall be dumped directly into the paver hopper. Under no circumstance shall ACP be placed onto the polymer-waterproofing membrane system ahead of the paver will not be permitted or at other locations.

The allowable ACP temperature of the asphalt mixture range at the start of compaction of ACP on the polymer waterproofing membrane system shall be between 123°C and 138°C ~~at the start of compaction.~~

~~17.5.4.3~~ 17.6.5.6 ~~17.7.5.6~~ Transition and Approach Road Paving Transition ACP

~~The ACP~~ The following specific requirements are in addition to those stated elsewhere within this specification.

ACP shall be placed as shown on the Drawings and, in the Special Provisions of the Contract, or as determined by the Consultant. ~~Lifts of ACP shall not exceed 70 mm.~~

The ACP temperature of the asphalt mixture shall be between 123°C and 138°C at the start of compaction of ACP for approach road transitions shall be a minimum of 123°C.

#### ~~17.7.6~~ Surface Defects and Material Tolerances

~~The completed pavement and all intermediate lifts shall be smooth, true to established cross-section and grade, thoroughly compacted and free from ruts, humps, depressions, or other irregularities. Any ridges, indentations or other objectionable marks left in the surface of the asphalt concrete pavement shall be eliminated by rolling or by other means. The Contractor shall be responsible for all costs including materials associated with the repair of Surface Defects.~~

#### ~~17.6.5.7~~ 17.7.6.1 Coring

When, in the opinion of the Consultant, compaction methods and/or procedures are not achieving specification requirements and nuclear density test measurements indicate that the specified compaction have not been achieved, the Consultant may require the Contractor to obtain cores for testing. The Contractor shall not take cores unless requested by the Consultant and Department. Core locations will be determined by the Consultant. Cores shall not be taken within the first lift of ACP in which waterproofing membranes are present below.

All coring and associated testing shall be completed by a third party independent testing agency that is prequalified to provide QA, mix design, and pavement smoothness testing services on Department projects.

The number of cores taken shall be the greater of five or one core for every 40 m<sup>2</sup> of ACP surface area. Cores shall have a diameter of either 100 mm or 150 mm. Contractors shall utilize core extraction methods that result in complete and undamaged cores.

Upon completion of coring the Contractor shall repair all core holes as follows:

- Core holes shall be completely de-watered, dried and liquid asphalt applied to the bottom and sides of the core hole and allowed to cure;
- ACP shall then be placed and compacted into the core hole until level with the surface of the adjacent pavement; and
- All repaired core hole locations shall be slurry sealed 100 mm beyond the core perimeter.

The Contractor shall submit core results to the Consultant within 3 days of core extraction.

All costs associated with ACP coring, testing and subsequent repairs shall be the responsibility of the Contractor and no additional or further payment will be made.

#### 17.6.6 Surface Requirements and Material Tolerances

##### 17.5.4.4 17.6.6.1 Smoothness

Except across the crown, the surface of the ACP shall be such that when tested with a 3 m long straight edge placed anywhere in any direction on the surface, there shall not be a gap greater than 3 mm between the bottom of the straight edge and the surface of the ~~deck anywhere below the straight edge.~~ ACP. The surface of ACP shall be checked by the Contractor, ~~as described above,~~ immediately after the final rolling. Any final lift ACP surface that does not meet the smoothness requirements shall be repaired by the Contractor to meet the requirements in a manner acceptable to the Consultant.

~~Any final lift pavement surface which does not meet the smoothness requirements given above shall be repaired by the Contractor to meet the requirements using methods acceptable to the Consultant.~~

~~Material removed by cold milling shall be hauled and disposed of by the Contractor, at his expense.~~

##### 17.5.4.5 17.6.6.2 ~~17.7.6.2~~ Segregation

Pavement segregation shall be classified in accordance with ~~section~~ Subsection 3.50.4.7.2-1, "Classifying Pavement Segregation", of the ~~Alberta Transportation~~ Standard Specifications for Highway Construction. The ~~Departments~~ Department's manual for "Paving Guidelines and Segregation Rating Manual" shall be used as reference in classifying segregation severity.

~~(<http://www.transportation.alberta.ca/Content/docType233/Production/pavsegman.pdf>)~~

During paving operations, the Contractor shall make every effort to achieve a finished surface that has a uniform closed texture and is free of segregated areas. At the end of paving each day or completion of a paving lift, the Consultant will perform an inspection of the paving to identify areas of pavement segregation. If segregation is present, the Contractor shall take immediate corrective action to the paving process to prevent any further occurrence of segregation. The Contractor, at his expense, shall repair segregated areas of all severities as follows:

- When slight or moderate segregation is identified in the bottom lift, ~~the Contractor shall identify and correct the cause of the segregation to prevent segregation in the top lift it shall be repaired using a slurry or hot mix patch.~~
- When any ~~moderate or severe~~ segregation ~~or centre of paver streak~~ is identified in the bottom lift, ~~the top 20 mm of the lift~~ shall be removed and replaced. Any damage to the bridge deck waterproofing system shall be repaired to the full satisfaction of the Consultant prior to subsequent paving operations. Subsequent lift(s) shall be modified to meet the specification requirements and approved by the Consultant.
  - ~~(a) When any slight or moderate or severe segregation or, including centre of paver streak, is identified in the top lift, the entire lift shall be removed and replaced.~~
  - ~~(b) When slight segregation is identified in the top lift and the total area of slight segregation does not exceed 0.5% of the total paved area, the areas identified top or final lifts it shall be repaired with using a slurry patch.~~
  - ~~(c) When slight segregation is identified in the top lift and the total area of slight segregation exceeds 0.5% of the total paved area, the entire lift shall be removed and replaced.~~
- ~~Methods of repair, removal and replacement shall be or hot mix patch. The extent of slight or moderate segregation will be reviewed and accepted by the Department and Consultant to determine if patching is acceptable or if the entire lift requires removal and replacement.~~
- 17.7.6.3 Obvious ~~When severe segregation is identified in the top lift, the entire lift shall be removed and replaced.~~

#### 17.6.6.3 Defects

All lifts of ACP shall be smooth, true to cross section and grade, and free from ruts, depressions, bumps, or other irregularities.

#### Defects

The finished surface of any lift shall have a uniform closed texture and be free of ~~visible signs of poor workmanship. Any obvious defects as determined by the Consultant such as, but not limited to the following, shall be promptly repaired in a manner acceptable to the Consultant.~~

- ~~(a) areas of excess or insufficient asphalt~~
- ~~(b) improper matching of longitudinal and transverse joints~~

- ~~(c) roller or tire marks~~
- ~~(d) cracking or tearing~~
- ~~(e) or sampling locations not properly reinstated.~~
- ~~(f) improperly constructed patches~~

~~17.5.4.6~~ 17.6.6.4 ~~17.7.6.4~~ Asphalt Content

~~For top lift material~~ The average asphalt content shall not be greater than  $\pm 0.50\%$  from the accepted mix design ~~asphalt content~~.

~~For bottom lift material the average asphalt content shall not be greater than  $\pm 0.65\%$  from the accepted mix design asphalt content.~~

~~17.5.4.7~~ 17.6.6.5 ~~17.7.6.5~~ Aggregate Gradation

For each lift of ~~placement~~ ACP the difference between the average gradation and the Job Mix Formula gradation shall not exceed the amounts ~~shown in the following table:~~ outlined in Table 17-3: Aggregate Gradation Variation.

Table 17.6

~~-3:~~ **Aggregate Gradation Variation**

<del>Sieve</del> <b>Designation</b> <u>Size</u> ( $\mu\text{m}$ )	<b>Maximum Permissible Variation *</b> <b>Percent by Weight Passing <sup>(1)</sup></b>
5000	$\pm 6$
1250	$\pm 4$
630	$\pm 3$
315	$\pm 3$
160	$\pm 2.5$
80	$\pm 2.0$

~~\*In any case the Average Gradation must meet the gradation requirements of Specification 3.2 Aggregate Production and Stockpiling~~

Notes ~~17.8~~

~~(1) Average Gradation must meet the gradation requirements of Subsection 3.2, Aggregate Production and Stockpiling, of the Standard Specifications for Highway Construction.~~

### 17.6.7 Repair Procedures

If any repairs, or removal and replacement are required, as determined by the Consultant, the Contractor shall submit proposed methods of repair or removal and replacement to the Consultant for review and acceptance a minimum of one week before commencement of the repair or removal and replacement Work.

All costs associated with repairs or removal and replacement shall be at the Contractor's expense.

### 17.6.8 ACP Surface Removal

Surface removal of ACP shall be completed in accordance with Subsection 20.3.2, Surface Removal.

### 17.6.9 ACP Gradeline Profiling

The gradeline will be designed by the Consultant to provide a smooth riding surface for the finished ACP. The Contractor shall assist the Consultant with profiling of the bridge structure and approaches.

For new construction projects, profiling shall occur before and after ACP placement.

For rehabilitation projects, profiling shall occur before and after surface removal, and after ACP placement.

Gradeline profiles will be produced by the Consultant and shall be used by the Contractor in placement of ACP. The following will be provided by the Consultant to the Contractor:

- Three parallel profile lines the entire length of the bridge:
  - Line No. 1 will be located 1.0 m from curb face.
  - Line No. 2 will be located 0.3 m in from the edge of mat adjacent to the crown.
  - Line No. 3 will be located 1.0 m from curb face.

The stations of Line No. 1, Line No. 2, and Line No.3 will be square to each other.

Additional profile lines will be produced when determined necessary by the Consultant.

- Stations will be established at the edges of deck joints and at 3.0 m intervals along the length of the bridge.
- At a minimum, profiles will include 30 m of approach at each end of the bridge at 3.0 m intervals.
- Profile plots will be to the following scales:
  - Horizontal: 10 mm = 1 000 mm

- Vertical: 1 mm (normal) or 1 mm = 5 mm (minimum)
- The proposed design gradeline will be a smooth line achieving a nominal thickness as shown on the Drawings or determined necessary by the Consultant.

The Contractor shall remove any deck surface temporary markings before placement that will adversely affect bonding of subsequently placed materials.

The Consultant will provide the summary of the proposed ACP thickness, to the nearest mm, at each control point. The Contractor is responsible for achieving the gradeline provided by the Consultant.

#### Measurement and Payment

#### ~~17.7 17.8.1~~

#### ~~17.5.5~~ 17.7.1 Payment by Lump Sum Price Bid

Payment for the supply and placement of asphalt concrete pavement will be made ~~on the basis of~~ the lump sum price bid for ~~the “Asphalt Concrete Pavement acceptably placed on the bridge deck, approach slabs”~~ for the applicable Mix Type less any applicable payment adjustments for density, and ~~approach roadways (as specified) and remaining in the completed work, which price shall include~~ will be full compensation for ~~the cost of furnishing~~ preparation of the asphalt mix designs and job mix formula; protection of the environment and bridge components; surface profiling; the supply and processing of aggregate; the supply and application of tack coat; the supply of asphalt cement; processing, hauling, placing and compacting the mix; sampling and testing; construction of ACP joints; and all labour, equipment, tools, materials, milling, hauling and placing the mix, quality control testing and incidentals necessary to complete the Work as shown on the Drawings and to the satisfaction of the Consultant.

#### ~~17.5.6~~ 17.7.2 17.8.2 Payment by Unit Price Bid

~~Payment~~ Measurement for payment of the supply and placement of asphalt concrete pavement will be ~~made on the basis of the unit price bid per tonne for the Asphalt Concrete Pavement by the tonnage of material~~ acceptably placed on, measured to the 0.1 tonne.

The quantity to be paid for will be calculated by the ~~bridge deck, approach slabs and approach roadways (as specified)~~ Consultant using the design profile and remaining in the completed work, which price shall include surface area shown on the Drawings or reviewed and accepted by the Consultant. The conversion factor from cubic metre volume to tonnage of asphalt concrete pavement will be 2.3.

Payment will be made at the unit price bid for "Asphalt Concrete Pavement" for the applicable Mix Type, less any applicable payment adjustments for density, and will be full compensation for the cost of furnishing preparation of the asphalt mix designs and job mix formula; protection of the environment and bridge components; surface profiling; the supply and processing of aggregate; the supply and application of tack coat; the supply of asphalt cement; processing, hauling, placing and compacting the mix; sampling and testing; and construction of ACP joints; and all labour, equipment, tools, materials, milling, hauling and placing the mix, quality control testing and incidentals necessary to complete the Work. The number as shown on the Drawings and to the satisfaction of tonnes to be paid the Consultant.

### 17.7.3 Payment Adjustment for Density

The Department reserves the right to reject asphalt concrete pavement that does not meet the specified requirements. The Department may, at its sole discretion, accept asphalt concrete pavement that does not meet the specified density at a reduced price.

ACP will be calculated considered acceptable at full payment or acceptable with payment reduction or rejection according to the values outlined in Table 17-4: Payment Adjustment for ACP Density (Measurement by Nuclear Gauge). Payment adjustment will be assessed for each mat of ACP placed. The Department may, at its sole discretion, reject all lift mats if any mat is found to be within rejection limits. Payment adjustment will be converted from a volume to tonnage basis using a factor of 2.3 tonnes per cubic metre.

**Table 17-4: Payment Adjustment for ACP Density (Measurement by Nuclear Gauge)**

<u>Average Mat Density / Control Density</u>	<u>Payment Reduction for ACP Density (% of Unit Price per tonne or Lump Sum)</u>
<u><math>\geq 98\%</math></u>	<u>Full Bid Price</u>
<u><math>\geq 97\% &lt; 98\%</math></u>	<u>Bid Price Less 15%</u>
<u><math>\geq 96\% &lt; 97\%</math></u>	<u>Bid Price Less 30%</u>
<u><math>&gt; 95\% &lt; 96\%</math></u>	<u>Bid Price Less 45%</u>
<u><math>\leq 95\%</math></u>	<u>Rejected</u>

When coring of ACP is required by the Consultant and the Department, ACP will be considered acceptable at full payment or acceptable with payment reduction or rejection according to the values outlined in Table 17-5: Payment Adjustment for ACP Density (Measurement by Core). Payment adjustment will be assessed for each mat of ACP placed. The Department may, at its sole discretion, reject all lift mats if any mat is found to be within rejection limits. Payment adjustment will be converted from a volume to tonnage basis using a factor of 2.3 tonnes per cubic metre.



**Table 17-5: Payment Adjustment for ACP Density (Measurement by Core)**

<u>Average Core Density / Marshall Brikette Density</u>	<u>Payment Reduction for ACP Density (% of Unit Price per tonne or Lump Sum)</u>
<u><math>\geq 97\%</math></u>	<u>Full Bid Price</u>
<u><math>\geq 96\% &lt; 97\%</math></u>	<u>Bid Price Less 15%</u>
<u><math>\geq 95\% &lt; 96\%</math></u>	<u>Bid Price Less 30%</u>
<u><math>&gt; 94\% &lt; 95\%</math></u>	<u>Bid Price Less 45%</u>
<u><math>\leq 94\%</math></u>	<u>Rejected</u>

**17.7.4 ACP Surface Removal**

Measurement for payment of ACP surface removal will be by the square metre, based on the field measurement. The conversion factor for Asphalt Concrete Pavement from cubic metre to tonne shall be 2.3 horizontal measurements to the nearest 0.1 m<sup>2</sup>.

Payment will be made at the unit price bid for "ACP Surface Removal", and will be full compensation for removal of the existing ACP to the depths specified; surface cleaning; disposal of debris; and all labour, equipment, tools and incidentals necessary to complete the Work to the satisfaction of the Consultant.



# STANDARD SPECIFICATIONS FOR BRIDGE CONSTRUCTION

## SECTION 18 CSP AND SPCSP STRUCTURES

### TABLE OF CONTENTS

<b>18.1</b>	<b>General</b>	<b>18-1</b>
<b>18.2</b>	<b>Supply and Fabrication</b>	<b>18-1</b>
18.2.1	Standards	18-1
18.2.2	Qualification	18-1
18.2.3	Engineering Data	18-1
18.2.3.1	Shop Drawings	18-1
18.2.3.2	SPCSP Plate Arrangement	18-2
18.2.4	Materials	18-2
18.2.4.1	Mill Test Reports	18-2
18.2.5	Fabrication	18-3
18.2.5.1	Fabrication of CSP	18-3
18.2.5.1.1	Sloped Ends	18-3
18.2.5.1.2	Termination of Lockseams	18-3
18.2.5.1.3	Cut Ends	18-3
18.2.5.1.4	Recorrugated Ends	18-3
18.2.5.1.5	Couplers	18-4
18.2.5.2	Fabrication of SPCSP	18-4
18.2.5.2.1	Sloped Ends	18-4
18.2.5.3	Standard Identification Plaques and Tags	18-4
18.2.6	Shop Inspection	18-4
18.2.6.1	Inspection, Sampling and Testing	18-4
18.2.6.2	Notification	18-4
18.2.7	Storage of Material	18-5
18.2.7.1	Stockpiles	18-5
18.2.7.2	Storage Stains	18-5
18.2.8	Handling of Material	18-5
18.2.9	Repair of Damaged Coatings	18-5
18.2.9.1	Galvanizing	18-5
18.2.9.2	Polymer	18-5
<b>18.3</b>	<b>Installation</b>	<b>18-6</b>
18.3.1	General	18-6
18.3.2	Care of Water	18-6
18.3.3	Excavation	18-7
18.3.4	Bedding	18-7
18.3.5	Assembly	18-8
18.3.5.1	CSP	18-9
18.3.5.2	SPCSP	18-9
18.3.6	Backfilling	18-10
18.3.7	Strutting for Composite Concrete/SPCSP Structure	18-11
18.3.8	Installation Tolerances	18-11
<b>18.4</b>	<b>Concrete Work</b>	<b>18-11</b>

<b>18.5 Substrate Holders.....</b>	<b>18-11</b>
<b>18.6 Heavy Rock Riprap.....</b>	<b>18-12</b>
<b>18.7 Measurement and Payment .....</b>	<b>18-12</b>

REFERENCE TABLES

Table No.

Details of Standard 2:1 Sloped End Sections for CSP Round Culverts .....	A
Details of Standard 2:1 Sloped End Sections for CSP Arch Culverts .....	B
Details of Standard 2:1 Sloped End Sections for SPCSP Round Culverts.....	C



**18.1 ~~18.1~~—General**

This ~~section describes~~specification is for the supply, fabrication, delivery and installation of Corrugated Steel Pipe (CSP) and Structural Plate Corrugated Steel Pipe (SPCSP) with an equivalent diameter of 1500 mm or greater.

~~Abbreviations for the various types. All work shall be carried out in accordance with this specification, as shown on the Drawings and Standard Drawings S-1418, Installation of metal pipe are as follows:~~

~~CSP—Corrugated Steel Pipe~~

~~CSP Arch—Corrugated Steel Pipe Arch~~

~~SPCSP—Structural plate Corrugated Steel Pipe~~

~~and SPCSP Arch—Structural plate Corrugated Steel Pipe Arch Structures, S-1847, Standard Identification Plaques and Benchmark Tablet, and S-1848, Standard Identification Tags.~~

**18.2 ~~18.2~~—Supply and Fabrication****18.2.1 ~~18.2.1~~—Standards**

The supply and fabrication of all galvanized, polymer coated and aluminum coated Corrugated Steel Pipe including couplers and appurtenances and Structural Plate Corrugated Steel Pipe shall be in accordance with the current edition of Canadian Standards Association (CSA) Standard G401 with additions and exceptions as described in this specification.

~~18.2.2—Only welders, welding operators and tackers approved by the Canadian Welding Bureau (CWB) in the particular category shall be permitted to perform weldments. Their qualifications shall be current and available for examination by the Consultant.~~

**18.2.2 Qualification**

~~All CSP and SPCSP shall be supplied and fabricated by a fabricator certified to CSA G401. Certification shall be completed by an independent agency accredited by the Standards Council of Canada.~~

**18.2.2~~18.2.2~~ 18.2.3 Engineering Data****18.2.2.1~~18.2.2.1~~ 18.2.3.1 Shop Drawings**

~~Five copies of the Shop drawings for SPCSP structures, beveled ends, elbows and any non-standard materials (e.g. elbows, bottomless arch details, horizontal ellipses, etc.) as well as bevel end details other component specified in the Special Provisions of the Contract shall be submitted to the Consultant for review prior to and acceptance a minimum of 2 weeks in advance of the commencement of fabrication. Review comments provided by the Consultant and/or the Department shall be incorporated into the shop drawings and resubmitted to the Consultant for review and acceptance prior to the commencement of fabrication.~~

~~18.2.2.2~~ Shop drawings shall be electronic unlocked PDF format. Each shop drawing shall include the Department's shop drawing identification block and have a sufficient blank space for the Consultant's review stamp. The Department's shop drawing identification block will be provided to the Contractor upon request. As a minimum, the following information shall be included on shop drawing submissions:

- Dimensions;
- Plate arrangements;
- Bolting details;
- Materials lists; and
- Assembly sequence.

The shop drawings will be reviewed by the Consultant solely to ascertain general conformance with codes and specifications. The Consultant's review and acceptance shall not be considered as relieving the Contractor of the responsibility for completing the Work in accordance with the Contract requirements.

#### ~~18.2.2.2~~ 18.2.3.2 SPCSP Plate Arrangement

~~The arrangement of the plates~~ For SPCSP structures ~~shall be shown on the shop drawings. The drawings shall also indicate that the~~ bolts in the corrugation valley of each longitudinal seam ~~are nearer~~ shall be closer to the visible ~~edge of the plate edge~~ than the bolts ~~in~~ located on the corrugation crest. ~~With the exception of "change of radii" locations, all~~ Longitudinal seams shall be staggered a minimum of  $2N$ , except where reviewed and accepted by the Consultant.

~~The Contractor shall use the shop drawings at the site to facilitate the assembly of the pipe.~~

#### 18.2.3 ~~Materials~~

#### 18.2.4 ~~Previously installed pipe shall not be used.~~ Materials

All pipe materials shall be new material supplied shall be clearly marked in accordance with the following information at intervals of not more than 3 m.

~~—~~ Manufacturer's Name or Trade Mark

~~—~~ Nominal Thickness CSA G401. CSP and Type of Metal SPCSP components shall be marked according to CSA G401.

~~—~~ Plate/Metal Coating (for non-standard coating)

~~—~~ Specification Designation

~~—~~ Plant Designation Code

~~—~~ Date of Manufacture

18.2.4.1 18.2.4 — Mill Test Reports

Mill test reports and product data sheets shall be provided for all materials in English.

Mill test reports and product data sheets shall be submitted to the Consultant for review and acceptance 2 weeks prior to the commencement of fabrication.

Where mill test reports originate from a mill outside Canada or the United States of America, the Contractor shall have mill test reports verified by a certified laboratory in Canada by testing the material to the specified material standards. The testing laboratory shall be certified to ISO/IEC 17025 by an organization accredited by the Standards Council of Canada for the tests required. Samples for testing shall be collected by personnel employed by the certified laboratory. A verification letter shall be provided by the certified laboratory that includes at a minimum, the applicable mill test reports, testing standards, date of verification testing, and declaration of material compliance with Contract requirements. The verification letter shall be signed by an authorized officer of the certified laboratory.

18.2.5 Fabrication~~18.2.2.3~~ 18.2.5.1 Fabrication of CSP~~18.2.4.1~~ Fabrication of CSP~~18.2.2.3.1~~ 18.2.5.1.1 Sloped Ends

Sloped end sections are required for each culvert unless otherwise noted on the Drawing or the culvert order. When 2:1 sloped end sections are specified by the order, the attached Tables A and B will apply unless stated otherwise.

~~18.2.2.3.2~~ 18.2.5.1.2 Termination of Lockseams

On pipes ~~1000~~ 1500 mm diameter or larger all lockseams terminating at the cut edges of a sloped or square end section shall have a 75 mm length of fillet weld run along both sides of the lockseam (staggered 300 mm apart) at each cut edge. The weld and surrounding area shall be zinc coated in accordance with CSA G401.

~~18.2.2.3.3~~ 18.2.5.1.3 Cut Ends

All cut edges of a sloped or square end section shall be made smooth by grinding so that all the burrs are removed. Any damaged protective coating shall be recoated with appropriate material in accordance with CSA G401.

~~18.2.2.3.4~~ 18.2.5.1.4 Recorrugated Ends

All corrugated steel pipes shall have ends recorrugated to provide annular corrugations for couplers.



~~18.2.2.3.5~~ 18.2.5.1.5 Couplers

Only annular corrugated couplers will be accepted unless specified otherwise on the order. The couplers for pipes 1600 mm and over in diameter shall be a minimum of 600 mm width. There shall be a minimum of five bolts ~~per~~ at every joint of every coupler.

~~18.2.2.4~~ 18.2.5.2 ~~18.2.4.2~~ Fabrication of SPCSP~~18.2.2.4.1~~ 18.2.5.2.1 Sloped Ends

Sloped end sections are required for each culvert unless otherwise ~~noted~~ specified on the ~~drawing or the order.~~ Drawings. When 2:1 sloped end sections are specified ~~by the order the attached~~ Table C ~~will~~ shall apply ~~unless stated otherwise~~.

18.2.5.3 ~~18.2.5~~ Standard Identification Plaques and Tags

Standard identification plaques and identification tags shall be supplied and installed in accordance with Section 13 Miscellaneous Iron, Standard Drawing S-1847, Standard Identification Plaques and Benchmark Tablet, and S-1848, Standard Identification Tags.

~~18.2.3~~ 18.2.6 Shop Inspection~~18.2.3.1~~ 18.2.6.1 ~~18.2.5.1~~ Inspection, Sampling and Testing

All materials shall be subject to inspection, sampling and quality assurance testing by the Consultant. The Contractor shall provide safe, convenient access acceptable to the Consultant for inspection and sampling of the materials, and shall cooperate in the inspection and sampling process when requested to do so.

Any material found unacceptable by the Consultant shall be replaced by the Contractor with acceptable material by the Contractor at the Contractor's expense.

~~Reinspection required due to faulty~~ Testing, inspection and related costs incurred by the Consultant as a result of defective work shall be paid for by the Contractor.

~~18.2.3.2~~ 18.2.6.2 ~~18.2.5.2~~ Notification

~~The Contractor shall contact the Consultant at least 72 hours~~ Prior to shipment. ~~This is of CSP or SPCSP, the Contractor shall notify the Consultant a minimum of 72 hours in advance~~ to facilitate inspection ~~of the materials at the plant.~~

18.2.5.3 ~~Failure to Notify for Inspection~~

~~Material that has not been inspected in the plant by the Consultant will not be passed for payment until such material has been inspected and acceptance.~~ The Contractor ~~may~~ shall be ~~charged with~~ responsible for all expenses incurred ~~for costs incurred by the Consultant to inspect CSP and SPCSP at the construction site, due to the material~~ Contractor's failure to be inspected at receive the site Consultant's acceptance, prior to shipping from the fabrication facility.

~~18.2.4~~ ~~18.2.7~~ ~~18.2.6~~ Storage of Material~~18.2.4.1~~ ~~18.2.7.1~~ ~~18.2.6.1~~ Stockpiles

All material shall be unloaded and stockpiled in a neat and orderly manner, so as to facilitate inspection and inventory, and in such a manner as to insure preservation of their quality and fitness for the work. Stockpiled materials, accepted on delivery as to quantity and observed condition, shall be subject to test, and shall meet requirements of the specifications at the time they are to be used in the work.

~~18.2.4.2~~ ~~18.2.7.2~~ ~~18.2.6.2~~ Storage Stains

~~In addition to CSA G401, when noted on the order,~~ SPCSP material is to be stored concave down. ~~This requirement is to reduce the occurrence~~

~~Galvanized material shall be stacked or bundled to prevent wet storage stains as defined by the American Hot Dip Galvanizers Association (AHDGA) publication "Wet Storage Stain". Any evidence of wet storage stain damage on plates that are not going to be assembled immediately shall be removed to the satisfaction of the Consultant.~~

~~18.2.5~~ ~~18.2.8~~ ~~18.2.7~~ Handling of Material

All culvert material shall be handled carefully and in such manner as to prevent bruising, scaling or breaking of the galvanized coating. Culvert material shall also be handled and unloaded without undue stress and in such a manner that the radii or dimensions of the pipes remain true. Coupling bands shall be shipped with all necessary hardware and fittings attached thereto, or in suitable shipping containers. All SPCSP bolts are to be shipped with plates. Where the material supplied is damaged, the Contractor shall immediately separate nested sections of plate or pipe to facilitate more detailed inspection. Culvert material designated by the Consultant as unacceptable, due to failure to meet specified requirements, shall be immediately repaired or replaced by the Contractor.

Where the Contractor's failure to satisfactorily stockpile, or to satisfactorily expedite repairs to damaged material, necessitates that the Consultant require this to be done separately, the cost of such work will be charged to the Contractor.

~~18.2.9~~ ~~18.3~~ Repair of Damaged Coatings~~18.2.9.1~~ Galvanizing

~~All damaged galvanized surfaces shall be repaired in accordance with CSA G401.~~

~~18.2.9.2~~ Polymer

~~Components with damage to polymer surfaces of less than or equal to 50 mm shall be repaired as follows:~~

- At the fabrication facility, repairs for the outside or external side shall use RAN VAR TPC-515-7 or DENSO Butyl 35 tape. Repairs for the inside or internal side shall use DENSO Butyl 35 tape.
- At the project site, repairs for both external and internal sides shall use DENSO Butyl 35 tape.

Components with damage to polymer surfaces greater than 50 mm shall be rejected when identified at the fabrication facility.

Components with damage to polymer surfaces greater than 50 mm identified at the project site will be assessed by the Consultant and the Department. The Consultant and Department will determine whether the damage to the polymer surface is repairable. If damage is determined repairable the Contractor shall submit a detailed repair procedure to the Consultant for review and acceptance. Repair work shall not commence until acceptance has been received from the Consultant. If the damage is determined to be irreparable, new components shall be provided by the Contractor at his expense.

### **18.3 Installation**

#### **General**

#### 18.3.1 ~~Metal pipes are flexible, and their resistance to deformation depends on careful~~

Installation of CSP and SPCSP structures shall not proceed until the excavation, foundation, and bedding and backfilling. As they deflect under vertical load they must build up wide support and therefore, to obtain maximum load bearing capacity, it is essential that the material underplacement has been reviewed and beside accepted by the pipe be of good quality, carefully placed Consultant.

The Contractor shall install CSP and properly shaped SPCSP structures to the lines and compacted grades as shown on the Drawings and as determined by the Consultant.

#### 18.3.2 **Care of Water**

In addition to ECO plan submission requirements, the Contractor shall also prepare and submit a separate care of water plan signed and sealed by a professional engineer registered in the Province of Alberta to the Consultant for review and acceptance a minimum of 2 weeks prior to the preconstruction meeting. The care of water plan shall outline the means and methods that will be used to control and manage water and/or ice at all times during the Work in accordance with all applicable environmental regulations.

The care of water plan will be reviewed by the Consultant solely to ascertain general conformance with environmental regulations, specifications and any applicable Special Provisions of the Contract. The Consultant's review and acceptance shall not be considered as relieving the Contractor of his full responsibility for the design, construction, monitoring, performance, and maintenance of the care of water plan.

18.3.3 Excavation specified

~~Excavations shall be carried out to the lines and grades shown on the Drawings. It is essential that the structure be kept, or as determined by the Department and Consultant, and in accordance with Section 1, Excavation, to permit placing of the bedding material.~~

~~Excavations shall be dewatered to the bottom of the excavation until all backfilling is complete~~ acceptably completed.

~~18.3.1 Care of Water~~

~~The Contractor shall be responsible to make adequate provisions for handling water in and around the construction site. Care of water will be considered incidental to the work and no separate or additional payment will be made.~~

~~18.3.2 Excavation~~

~~Excavation shall be done to the lines and grades shown on the drawings, or as determined by the Department and Consultant, and in accordance with the appropriate sections of Section 1 "Excavation" of the Specifications for Bridge Construction, to permit placing of the bedding material.~~

~~18.3.1~~ 18.3.4 ~~18.3.3~~ Bedding

Where the bottom of the excavation lies at 600 mm or less below the pipe invert the fill material shall be ~~compact~~ compacted by the Contractor to a minimum of 95% of Standard Proctor Density at optimum moisture content. Where the bottom of the excavation extends more than 600 mm below the pipe invert, the fill material shall be compacted at the 600 mm level to a minimum of 95% of Standard Proctor Density at optimum moisture content. The structural fill shall be placed in lifts not exceeding 150 mm ~~when compacted, prior to compaction.~~ The Contractor shall use whatever materials, labour, equipment and incidentals necessary to achieve a stable bed.

~~When in the opinion of the Department and Consultant foundation conditions are considered soft and unstable, the Contractor~~ The Contactor shall ~~supply and place woven geotextile filter fabric at the base of the excavation between the clay seals before placing granular backfill material,~~ as shown on Standard Drawing S-1418. ~~The, Installation of CSP and SPCSP Structures.~~

~~The supply and placing of the woven geotextile filter fabric will be considered incidental to the Work and no separate or additional payment will be made.~~

~~The physical properties and minimum requirements of~~ woven geotextile filter fabric shall be in accordance with ~~the following table:~~ Table 18-1, Woven Geotextile Filter Fabric Requirements.

**Table 18-1: Woven Geotextile Filter Fabric Requirements**

<b>Woven Geotextile Filter Fabric</b>	
<b>Specifications and Physical Properties</b>	<b>Minimum Requirement</b>
Grab Strength <u>(ASTM D4632)</u>	<del>1275 N</del> <u>1275 N</u>
Elongation (Failure)	15%
<u>CBR</u> Puncture Strength <u>(ASTM D6241)</u>	275 N
<u>Burst Strength</u>	<u>3.6 MPa</u>
Trapezoidal Tear <u>(ASTM D4533)</u>	475 N
<u>Minimum Fabric Lap to be 1000 mm</u>	

~~The granular~~ The minimum geotextile filter fabric lap shall be 1000 mm.

The crushed aggregate material within 150 mm of the bottom of pipe shall be placed in a loose uncompacted state. All other structural fill, including the clay seepage cutoffs, shall be compacted to a minimum of 95% of Standard Proctor Density at optimum moisture content.

The top of the bedding is that portion of the structural fill in contact with the bottom of the pipe and shall be constructed to the exact grade ~~established by as shown on the~~ Consultant Drawings. Where camber is specified, the top of the bedding shall be constructed on a gradual crest curve with no sudden breaks in the grade. Where preshaping is specified, the top of the bedding shall be constructed to the exact curvature of the bottom plates. The top of the preshaping shall be 200 mm to 300 mm below the horizontal seam which joins the sidewall to the bottom plates, or as shown on the Drawings.

#### ~~18.3.2~~ 18.3.5 ~~18.3.4~~ Assembly

~~Placing~~ Assembly of CSP and assembly of the pipe SPCSP structures may proceed only after the excavation, foundation and bottom bedding material and shape have been ~~inspected~~ reviewed and accepted by the Consultant.

The shape of CSP and SPCSP structures shall be maintained within 2% of design dimensions. When the Contractor supplies and installs devices and/or use methods to maintain the shape of the structure, they shall be such that no local distortions of the pipe or other signs of distress occur. Horizontal strutting shall not be used unless the Contractor obtains written acceptance from the Consultant. The Contractor shall continuously monitor the shape of the pipe during installation to ensure the specified design shape is achieved.

Assembly ~~of~~ shall be completed in accordance with the reviewed and accepted shop drawings.

18.3.2.1 18.3.5.1 CSP

CSP sections shall be laid so that the ends are in close contact. Couplers shall be well fitted and evenly tightened all around the pipe. ~~Where required,~~ Joints shall be sealed using sealing materials supplied by the Contractor and approved by the Consultant non-woven geotextile. Assembly of SPCSP

CSP couplers shall be completely wrapped with a 2 m wide layer of non-woven geotextile, centered over the coupler prior to backfilling.

18.3.5.2 SPCSP

SPCSP shall be assembled ~~as shown on the drawings which will be provided by~~ in accordance with the pipe supplier reviewed and ~~as outlined below~~ accepted shop drawings and as follows:

- ~~(a)~~ — The pipe shall be assembled on the invert bed as ~~detailed~~ shown on the Drawings and reviewed and accepted by the Consultant.;
- ~~(b)~~ — All bolted seams shall be properly lapped and plates shall be in contact for the full width and length of the lap. The bolts in the valley of each longitudinal seam shall be nearer to the visible edge of the plate than the bolts in the crest.;
- ~~(c)~~ — Assembly and loose bolting of the side arc and top arc plates may ~~then~~ proceed ~~to~~ starting from the upstream end of the structure and progressing towards the downstream end.;
- ~~(d)~~ — After two complete rings have been loosely assembled, the vertical dimensions shall be checked and where necessary adjusted with horizontal cables and/or supports to obtain design rise dimensions.;
- ~~(e)~~ — Each adjacent ring shall then be assembled and adjusted in a similar manner until the entire structure is loosely assembled and conforms to design geometry with nested plates.;
- ~~(f)~~ — The vertical axis shall be upright and the longitudinal seams shall be straight. Rotation of the pipe and/or ~~spiralling~~ spiraling of the longitudinal seams shall not be permitted.;
- ~~(g)~~ — Adjustments shall be made to produce design dimensions with fully nested laps. When horizontal tie cables are used for shape adjustment, adequate means shall be taken to ensure distribution of concentrated forces at the pipe walls. Distortion of the pipe side walls at the cable points will not be tolerated.;
- ~~(h)~~ — Bolts shall be torqued to not less than 200 Newton-metre (Nm) and not more than 340 Nm. This includes bolts which connect special features to the pipe. Where the supplier's specification for torque differs from this range the Contractor shall contact the Consultant for direction. Bolts shall be tensioned only once and shall not be reused;

- ~~(i)~~—Distortion of bolt holes caused by over-torquing, or poor assembly methods will not be permitted. ~~Where Proposed bolt holes~~ additional holes are required they to those shown on the shop drawings shall be reviewed and accepted by the Consultant and the Department. Any additional holes reviewed and accepted shall be drilled. Torch cutting of holes or welding on ~~the pipeplate sections~~ will not be permitted.
- ~~(j)~~ ~~The shape of the pipe shall be maintained within 2% of design dimensions. This includes the rise, the span, and any chords or chord offsets identified by the Consultant. Where required, the Contractor shall supply and install devices and/or use methods to maintain the shape of the structure. These devices shall not cause local distortions of the pipe or other signs of distress. Horizontal strutting shall not be used unless the Contractor obtains written acceptance from the Consultant. Restraining devices shall be left in place until the structural fill reaches the top of the sidewall or as determined by the Consultant. When determined by the Consultant, the Contractor shall supply and install devices to monitor the shape of the pipe.~~

~~18.3.5 Where conflicting requirements exist between this specification and the manufacturer's shop drawings, the specification requirements shall govern.~~

#### ~~18.3.3~~18.3.6 Backfilling

~~When~~ The assembly of the structure ~~has been~~ must be accepted by the Consultant, before backfilling with Granular crushed aggregate material and/or non-granular materials as specified on the Drawings ~~may proceed~~. Backfilling shall be in accordance with the current version of Standard Drawing S-1418 and Section 2—“ Backfill” ~~of the Specifications for Bridge Construction.~~ In addition, the following requirements shall be met:;

- Bedding material shall be crushed aggregate Des 2 Class 25;
- When the air temperature is below 0 °C, no backfilling is allowed unless otherwise accepted by the Department and Consultant. When/if backfilling is deemed acceptable due to extenuating circumstances, the Contractor shall submit a cold weather backfilling procedure to the Consultant for review and acceptance is granted, a minimum of 2 weeks prior to backfill placement. All backfill materials shall be in a thawed state when placed and compacted. No backfill material will be permitted to be placed on frozen substrate:;
- The backfilling under the haunches shall be compacted in thin layers filling all corrugations and ensuring firm contact with the entire bottom surface of the pipe:;
- The backfilling shall fill each corrugation, be free of voids and provide uniform support to the pipe. The backfill shall be placed such that the level of fill on one side of the pipe does not exceed the level of fill on the other side of the pipe by more than 300 mm:;
- The backfill shall be placed and compacted by equipment moving parallel to the pipe with simultaneous handwork along the pipe. Large earth moving equipment and large compaction equipment shall not be permitted within 1.0 m of the pipe:;

- The first 300 mm of the backfill over the pipe shall be placed, levelled and compacted without vibration. Subsequent fill over the pipe shall be placed and compacted by equipment moving perpendicular to the longitudinal axis of the pipe. The Contractor shall obtain the Consultant's acceptance before using any equipment above the pipe.
- The Contractor shall supply suitable material for the compacted non-granular backfill. ~~Generally the material shall consist of clay or till materials.~~ Highly plastic ~~clay material~~ clays or material with high silt content will not be permitted. ~~for use as non-granular backfill.~~ The quality of the material, and the methods of placing and compacting, shall be reviewed and accepted by the Consultant before commencement of ~~this stage of construction the Work; and~~
- ~~18.3.6 Strutting for Composite Concrete/SPCSP Structure~~ Clay seal material shall be highly plastic clay with a minimum plasticity index of 40. Clay seal materials shall be classified in accordance with ASTM D2487.

#### ~~18.3.4~~ 18.3.7 Strutting for Composite Concrete/SPCSP Structure

For composite concrete/SPCSP structures strutting and scaffolding shall be supplied and installed as shown on the Drawing.

#### ~~18.4 Concrete Work~~

##### 18.3.8 Installation Tolerances

The shape of CSP and SPCSP structures shall be within 2% of design dimensions during all stages of the Work and at construction completion.

#### 18.4 Concrete Work

Where detailed and specified, the concrete work shall be constructed as shown on the Drawings and in accordance with ~~the Specifications for Bridge Construction;~~ Section 4, Cast-In-Place Concrete and Section 5, Reinforcing Steel.

~~Section 4 – Cast-In-Place Concrete~~

~~Section 5 – Reinforcing Steel~~

#### ~~18.5 Fish Baffles~~

##### 18.5 Fish baffles Substrate Holders

Substrate holders shall be ~~constructed~~ installed as shown on the Drawings and be fabricated in accordance with the ~~applicable~~ specified Standard Specifications for Bridge Construction sections.



**18.418.6** ~~18.6~~ **Heavy Rock Riprap**

~~Heavy rock riprap shall, including non-woven geotextile filter fabric, shall meet the requirements of Section 10, Heavy Rock Riprap and shall be placed as shown on the Drawings and shall conform to the Specifications for Bridge Construction: Section 10 "Heavy Rock Riprap".~~

**18.518.7** ~~18.7~~ **Measurement and Payment**

~~Unless otherwise specified on the drawings or in the "Special Provisions"~~ Payment for the following items: will be made at the unit prices or lump sum prices bid:

- Detour Road - Construct and Maintain;
- ~~Salvage or Demolition,~~ Disposal and Salvage of Existing Structure;
- Excavation;
- SPCSP ~~—~~ Supply;
- CSP with couplers ~~—~~ Supply;

~~— Granular Backfill — Des 6 Class 80~~

- ~~—~~ Crushed Granular Aggregate;

~~— Backfill — Des 2 Class 40~~

- ~~—~~ Non-Granular Backfill;
- SPCSP ~~—~~ Assembly;
- CSP ~~—~~ Assembly;
- Concrete End Treatment;

~~— Fish Baffles~~

- Reinforcing Steel;
- Concrete;
- Substrate Holders;
- Heavy Rock Riprap;
- Miscellaneous Iron;
- Guardrail; and
- Roadway Work;

~~Such payments will be on the basis of the unit price or lump sum prices bid for each of these items of work, acceptably completed. The prices bid shall include full compensation for the cost of furnishing all labour, materials, equipment, tools, and incidentals necessary to complete the Work as shown on the Drawings and to the satisfaction of the Consultant.~~

~~When specified, payment for the supply and assembly of SPCSP or CSP with couplers can be made on the basis of the unit price bid per metre in place. The price bid shall be full compensation of the cost of furnishing all labour, materials, equipment, tools and incidentals necessary to complete the work.~~

~~When materials are delivered to the worksite, payments for: Unit price payments will be based on actual quantities acceptably completed and remaining in the Work, as determined by the Consultant.~~

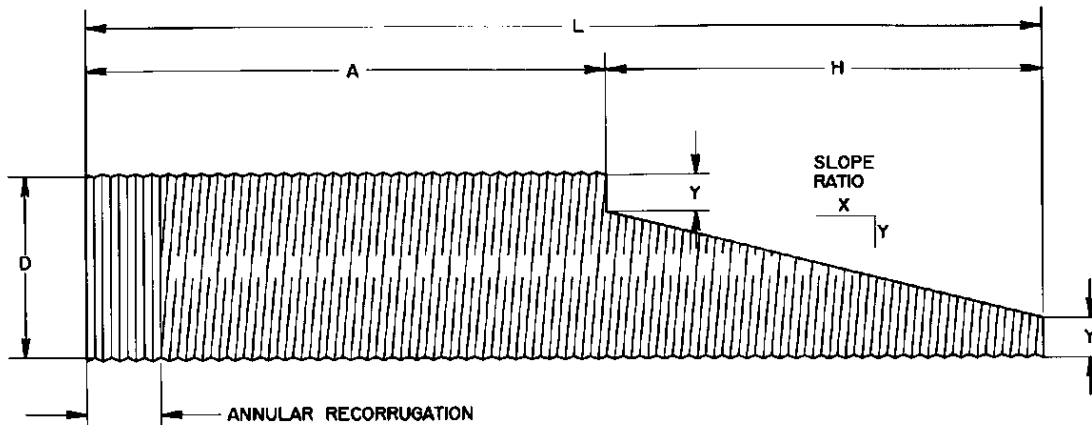
~~Payment for “SPCSP – Supply” **and/or** “CSP with Couplers – Supply” will be made to a maximum of 90% of the ~~cost of~~ lump sum or unit price bid once the materials ~~based upon the applicable supplier’s invoices. Payments will not be initiated until the Contractor submits the invoices have been acceptably supplied and delivered~~ to the Consultant ~~upon receipt and acceptance of the material at the project~~ site. The remaining ~~payment~~ 10% of the lump sum or unit price bid will be made ~~after~~ once the structure ~~is~~ has been acceptably backfilled and installation tolerances have been measured, reviewed and accepted by the Consultant.~~

~~When woven~~ All costs associated with the supply and installation of geotextile filter fabric ~~is,~~ when specified, the supply, placing, equipment and tools necessary to acceptably complete this work will be considered incidental to the Work, and no separate or additional payment ~~for this~~ will be made.

~~All cost associated with the care of water will be considered incidental work~~ to the Work, and no separate or additional payment will be made.

~~When woven geotextile filter fabric is not specified but deemed necessary as determined by the Consultant due to unsuitable foundation conditions, the supply, placing and the related work will be paid for by a negotiated lump sum price or in accordance with 1.2.25 “Extra Work” of the~~

TABLE A  
 DETAILS OF STANDARD 2:1 SLOPED END SECTIONS  
 FOR CSP ROUND CULVERTS



INSIDE DIAMETER "D" mm	SLOPE RATIO X:Y	"Y" mm	"A" m	"H" m	INVERT LENGTH OF SLOPED END SECTION "L" m
1200	2:1	150	4.2	1.800	6.0
1400	2:1	200	4.0	2.000	6.0
1600	2:1	200	3.6	2.400	6.0
1800	2:1	300	3.6	2.400	6.0
2000	2:1	300	5.2	2.800	8.0
2200	2:1	300	4.8	3.200	8.0
2400	2:1	400	4.8	3.200	8.0
2700	2:1	400	6.2	3.800	10.0
3000	2:1	500	6.0	4.000	10.0
3300	2:1	500	5.4	4.600	10.0
3600	2:1	600	5.2	4.800	10.0

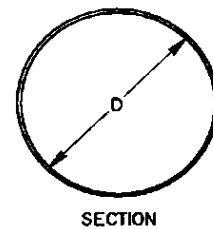
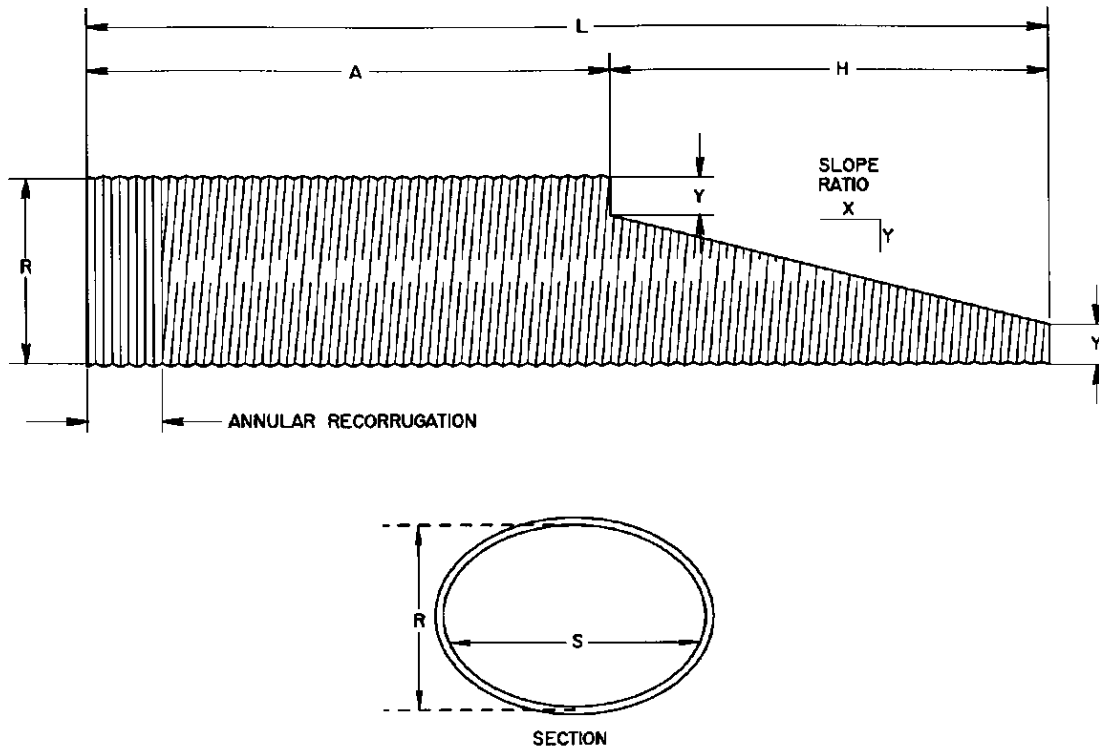




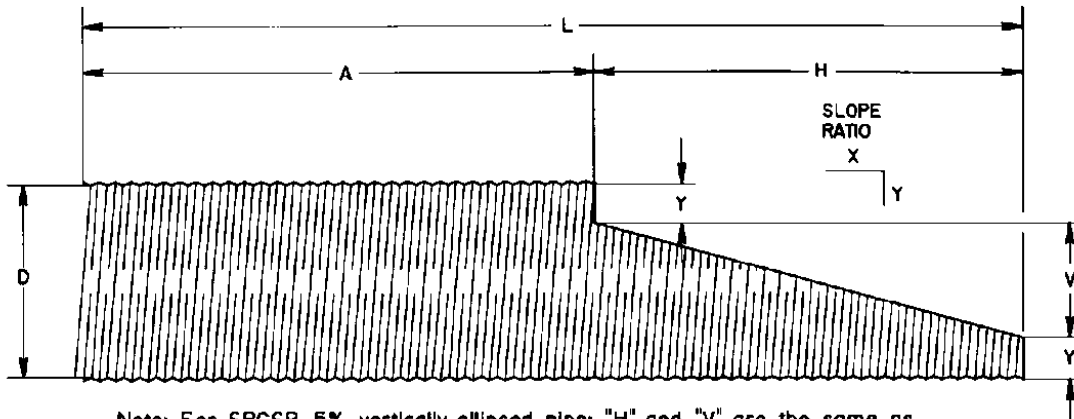
TABLE B  
 DETAILS OF STANDARD 2:1 SLOPED END SECTIONS  
 FOR CSP ARCH CULVERTS



EQUIVALENT INSIDE DIAMETER "D" mm	SPAN "S" mm	RISE "R" mm	SLOPE RATIO X:Y	"Y" mm	"A" m	"H" m	INVERT LENGTH OF SLOPED END SECTION "L" m
1200	1390	970	2:1	150	4.660	1.340	6.0
1400	1630	1120	2:1	200	4.560	1.440	6.0
1600	1880	1260	2:1	250	4.480	1.520	6.0
1800	2130	1400	2:1	300	4.400	1.600	6.0

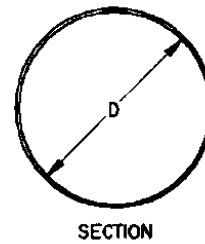


TABLE C  
 DETAILS OF STANDARD 2:1 SLOPED END SECTIONS  
 FOR SPCSP ROUND CULVERTS



Note: For SPCSP 5% vertically ellipsed pipe: "H" and "V" are the same as for a round pipe of equivalent diameter; "Y" is variable with the increase in rise.

INSIDE DIAMETER "D" mm	SLOPE RATIO X:Y	Y* mm	H* m
1500	2:1	293	1.828
1660	2:1	373	1.828
1810	2:1	295	2.440
1970	2:1	375	2.440
2120	2:1	298	3.048
2280	2:1	378	3.048
2430	2:1	453	3.048
2590	2:1	533	3.048
2740	2:1	455	3.658
3050	2:1	610	3.658
3360	2:1	765	3.658
3670	2:1	920	3.658
3990	2:1	1080	3.658
4300	2:1	1235	3.658
4610	2:1	1390	3.658
4920	2:1	936	6.096
5230	2:1	1091	6.096
5540	2:1	1246	6.096
5850	2:1	1095	7.320
6160	2:1	1250	7.320
6470	2:1	1405	7.320
6780	2:1	1560	7.320
7090	2:1	1715	7.320
7400	2:1	1870	7.320
7710	2:1	2025	7.320
8020	2:1	2180	7.320







STANDARD SPECIFICATIONS FOR BRIDGE CONSTRUCTION

**SECTION 19 PAINTED ROADWAY MARKINGS**

TABLE OF CONTENTS

<b>19.1</b>	<b>General</b> .....	<b>19-1</b>
<b>19.2</b>	<b>Materials</b> .....	<b>19-1</b>
	19.2.1 Paint and Glass Beads.....	19-1
<b>19.3</b>	<b>Protection of Bridge Structure</b> .....	<b>19-1</b>
<b>19.4</b>	<b>Application</b> .....	<b>19-1</b>
	19.4.1 Sampling and Testing .....	19-2
<b>19.5</b>	<b>Payment</b> .....	<b>19-2</b>



## 19.1 General

This specification is for the supply of all painting materials and the painting of roadway markings on bridge decks and approach roadways.

## 19.2 ~~19.2~~—Materials

### 19.2.1 Paint and Glass Beads

The Contractor shall supply paint and glass bead materials that are on the Department's ~~Approved~~ Products List and have been approved. The Contractor shall submit written confirmation from the manufacturer that the materials supplied shall meet all specified requirements.

The Contractor shall provide the Consultant with the following information prior to commencing the Work:

- Names and mailing addresses of the suppliers and manufacturers; and
- Paint formulation.

The Contractor shall advise the Consultant of any change in paint formulation. ~~No paint formulation~~ Paint shall not be diluted or mixed with a different formulation or with any other material without the specific acceptance of the Department.

The Contractor shall take all necessary steps to prevent contamination of the materials. Paint shall be protected from freezing.

## 19.3 ~~19.3~~—Protection of Bridge Structure

The Contractor shall take due precautions against damaging or disfiguring any portion of the structure. ~~He~~ The Contractor shall guard against spatters, overspray, splashes or smirches of paint or associated paint materials, and damages caused by fuel or lubricants used with his equipment.

## 19.4 ~~19.4~~—Application

The Contractor shall paint lane lines, continuity lines, edge lines and directional arrows or dividing lines on the roadway and bridge deck to restore the painted markings as existed prior to the construction work, or as shown on the drawings, or as specified. Centrelines and shoulder lines shall be 100 mm wide. Broken centrelines shall be 3 m in length followed by a 6 m space. The Contractor shall ensure that painted lines match the existing lines exactly, unless otherwise determined by the Consultant.

The substrate surface shall be clean, dry and at least 10°C in temperature for waterborne paint during the paint application. All painted messages and lines shall be applied at the rate of ~~0.4~~ 0.38 litres/km of solid 100 mm wide line and 0.4 litres/m<sup>2</sup> of actual painted area for painted messages. Glass beads shall be applied immediately following the paint application at a uniform application rate of 600 g/~~litre~~ of paint. Messages and lines initially applied at less than the specified rate, as determined by the Consultant shall be repainted at the expense of the Contractor.

All painted markings shall be uniform in thickness with no spatter, excessive overspray, or other defects.

Construction and public traffic shall not be permitted to travel on the painted markings until after the paint has cured sufficiently ~~cured~~ to prevent damage or pickup.

#### 19.4.1 ~~19.5~~ Sampling and Testing

When requested by the Consultant, the Contractor shall supply the Consultant with quality assurance samples and the manufacturer's quality control test results. The manufacturer's quality control results shall include a minimum of Specific Gravity, Hiding Power, Dry to Traffic and Viscosity results. A minimum of one quality assurance sample per batch shall be taken for glass beads as per TLT-601, Sampling Glass Beads. A minimum of one quality assurance sample per color per batch shall be taken for paint as per TLT-636, Sampling Traffic Paint. Samples requested by the Consultant will be forwarded to the Department's designated quality assurance testing firm for third party quality assurance. The Consultant and the Department will review the quality assurance testing and determine the acceptability of the materials. If the materials supplied are determined not acceptable. The Contractor, at his expense, shall remove and replace any materials determined unacceptable, to the full satisfaction of the Consultant.

All materials are subject to inspection, sampling and testing by the Consultant, and the Contractor shall provide safe access and co-operate in the sampling and testing process when requested to do so.

#### **19.5 Payment**

Unless otherwise specified, Painted Roadway Markings ~~All costs associated with the application of painted roadway markings, including the cost of furnishing all labour, materials, equipment and tools necessary to acceptably complete the work~~ supply of materials, will be considered incidental to the Work, and no separate or additional payment ~~for this incidental work~~ will be made.

# STANDARD SPECIFICATIONS FOR BRIDGE CONSTRUCTION

## SECTION 20 DECK OVERLAY AND CONCRETE REHABILITATION

### TABLE OF CONTENTS

<b>20.1</b>	<b>General</b> .....	<b>20-1</b>
<b>20.2</b>	<b>Traffic Accommodation</b> .....	<b>20-1</b>
<b>20.3</b>	<b>Surface Preparation for Concrete Overlay</b> .....	<b>20-1</b>
20.3.1	General.....	20-1
20.3.2	Surface Removal .....	20-2
20.3.3	Deck Surface Abrasive Blasting .....	20-3
<b>20.4</b>	<b>Concrete Repair</b> .....	<b>20-3</b>
20.4.1	General.....	20-3
20.4.2	Partial Depth Repair.....	20-4
20.4.3	Full Depth Repair .....	20-5
<b>20.5</b>	<b>Deck Overlay</b> .....	<b>20-7</b>
20.5.1	General.....	20-7
20.5.2	Concrete .....	20-7
20.5.3	Gradeline Profiles/Dry Run.....	20-8
20.5.4	Cement/Silica Fume Slurry Grout.....	20-9
20.5.5	Conveyance of Concrete on Deck.....	20-10
20.5.6	Mixing Overlay Concrete.....	20-10
	20.5.6.1 Pre bagging for Site Batching .....	20-10
	20.5.6.2 Mixer Trucks and Water Supply for Site Batching .....	20-11
20.5.7	Inspection and Testing.....	20-12
20.5.8	Concrete Placement.....	20-13
	20.5.8.1 General.....	20-13
	20.5.8.2 Surface Texture .....	20-13
	20.5.8.3 End of Overlay .....	20-14
	20.5.8.4 Longitudinal and Transverse Overlay Construction Joints.....	20-14
	20.5.8.5 Curing Concrete .....	20-14
	20.5.8.6 Application of Sealer .....	20-15
	20.5.8.7 Opening to Traffic .....	20-15
<b>20.6</b>	<b>Measurement and Payment</b> .....	<b>20-15</b>
20.6.1	Surface Removal .....	20-15
20.6.2	Partial and Full Depth Repairs .....	20-15
20.6.3	Deck Surface Abrasive Blasting .....	20-16
20.6.4	Deck Overlay Concrete.....	20-17
	20.6.4.1 Supply of Deck Overlay Concrete.....	20-17
	20.6.4.2 Placement of Deck Overlay Concrete .....	20-17



## 20.1 General

Deck overlay and concrete rehabilitation ~~work~~ may consist of, but not be limited to, surface removal, concrete repair, surface preparation, and/or deck overlay. The Work shall be completed as shown on the Drawings, in accordance with the requirements of this specification, Section 4, Cast-in-place Concrete, Section 5, Reinforcing Steel, and as described in the Special Provisions of the Contract.

~~20.2~~—Details of proposed material disposal locations shall be submitted to the Consultant for review and acceptance prior to disposing of materials.

## 20.2 Traffic Accommodation

Unless otherwise ~~approved~~reviewed and accepted by the Consultant, all rehabilitation projects which include either a concrete or ACP overlay shall be ~~carried out~~completed in stages and ~~shall have~~ a minimum of one undisturbed travel lane shall be available for the accommodation of public traffic at all times during construction.

Traffic accommodation shall be in accordance with the requirements of ~~Specification~~Subsection 7.1, “Traffic Accommodation and Temporary Signing”<sub>7.1</sub> of the Standard Specifications for Highway Construction and as described in the Special Provisions of the Contract.

## 20.3 ~~20.3~~—Surface Preparation for Concrete Overlay

### 20.3.1 ~~20.3.1~~—General

Surface preparation includes all work necessary to prepare the bridge for deck overlay concrete placement. This work includes, but is not limited to, the following:

- ~~Surface removal~~<sub>;</sub>
- ~~Removal and disposal of existing concrete paving lips~~<sub>;</sub>
- ~~Partial depth repair~~<sub>;</sub>
- ~~Full depth repair~~<sub>;</sub>
- ~~Sandblasting~~Abrasive blasting of concrete surfaces to be overlaid; and
- ~~Removal and reinstallation of bridgerail, as required, to accommodate screed rails~~<sub>;</sub>

Jack hammers heavier than nominal 14 kg class and chipping hammers heavier than nominal 7 kg class shall not be used for concrete removal.

20.3.2 ~~20.3.2~~ Surface Removal

Surface removal shall be carried out in stages. The Contractor shall complete surface removal operations to the depth(s) shown on the Drawings or as described in the Special Provisions ~~of the Contract~~. The Contractor shall submit details of his proposed surface removal methods to the Consultant for review and acceptance a minimum of ~~one~~ week prior to the scheduled commencement of ~~this~~the Work.

Surface removal shall be carried out as close as possible to all curbs, medians, barriers, drains, deck joints, and other bridge components without causing damage. Chipping equipment shall be used in these areas to complete removal operations. Concrete curb and deck joint paving lips within the limits of the surface removal area shall be removed, including the reinforcing steel projecting into these components. For bridges that do not have formal deck joints at the abutments, the Contractor shall saw cut through the full depth and width of the wearing surface at both ends of the bridge or at the transition paving limits prior to commencing removal operations.

When the specified removal depth includes more than 5 mm of concrete removal and cold ~~-~~milling methods are proposed by the Contractor, small milling machines having a maximum removal width of 1.2 m shall be used. Monitoring and making adjustments to the removal depth shall be carried out by the Contractor on an ongoing, as required basis to ensure an accurate depth of material removal is maintained throughout the milling operations. If the Contractor removes material in excess of 5 mm from that specified without prior approval from the Consultant, the costs associated with the additional material replacement quantities shall be at the Contractor's expense.

The Contractor shall remove milling debris from behind the cold ~~-~~milling machine and clean the milled surface on a continuous basis, as close to the milling machine as is safely practicable. Debris removal and surface cleaning details shall be included in the Contractor's proposed surface removal method submission. ~~The Contractor shall dispose of all debris resulting from surface removal operations at an approved location.~~

Reinforcing steel or other bridge components damaged as a result of the Contractor's surface removal operations shall be repaired or replaced by the Contractor at his expense.

Upon completion of surface removal operations, including thorough cleaning and drying of the deck surface and removal of all equipment, the Consultant will inspect the deck surface and identify areas of unsound concrete to be repaired. Repairs shall be carried out in accordance with Subsection ~~20.4, Concrete Repair~~20.4, Concrete Repair.



20.3.3 ~~20.3.3~~ Deck Surface ~~Sandblasting~~Abrasive Blasting

Prior to deck overlay concrete placement, the Contractor shall ~~sandblast~~abrasive blast the entire deck surface and the vertical faces of the curb, median and parapet up to a height equal to the overlay thickness. Adequate shielding shall be provided to protect any repaired epoxy coated reinforcing steel or galvanic anodes. ~~Sandblasting~~Blasting shall be carried out to a concrete surface profile 3 or 4 using the extent necessary to~~ICRI (www.icri.org) Guideline No. 310.2R-2013, Selecting and Specifying Concrete Surface Preparation for Sealers, Coatings, Polymer Overlays, and Concrete Repair that~~ uniformly ~~expose~~exposes fine aggregate.

Following ~~sandblasting~~blasting, the Contractor shall clean the deck surface so that it is free of all ~~sand~~abrasive material, dust and other contaminants to the satisfaction of the Consultant. ~~Debris from the cleaning operations shall be disposed of at an approved location.~~

Once accepted by the Consultant, the Contractor shall be responsible for maintaining the cleaned deck in satisfactory condition until placement of deck overlay concrete. Additional preparation or cleaning, including ~~sandblasting~~abrasive blasting, that may become necessary during this period shall be carried out by the Contractor at his expense.

20.4 ~~20.4~~ Concrete Repair

20.4.1 ~~20.4.1~~ General

~~At~~ Repair areas ~~other than the deck substrate, the~~and limits of concrete removal will be determined by the Consultant.

The ~~perimeters~~perimeter of repair areas shall be ~~sawcut with~~saw cut to a depth of 25 mm. When concrete cover above the reinforcing steel is less than 25 mm, the depth of the saw cut shall be modified such that the saw blade does not come within 6 mm of the reinforcing steel. All saw cuts shall be made in neat, and perpendicular, 25 mm deep cuts lines.

The Contractor shall remove the areas of unsound concrete by chipping, scabbling or other means ~~approved~~reviewed and accepted by the Consultant. Removal operations at each location shall result in a sound surface suitable for bonding to the deck overlay concrete or repair material.

The Contractor shall contain all debris resulting from concrete removal operations ~~and dispose of the material at an approved location.~~ Methods of containment shall not result in damage to the existing bridge or surrounding areas, ~~and are subject to acceptance by the Consultant.~~

20.4.2 Concrete used for partial depth or full depth repairs shall meet the minimum specified 28 day compressive strengths for the applicable class of concrete.

Patching materials shall meet the minimum 28 day compressive strength stated on the manufacturer's published product data sheet.

#### 20.4.2 Partial Depth Repair

~~Partially exposed reinforcing steel shall be entirely exposed by removal of the concrete to a depth of 25 mm below the bars.~~

At partial depth repair areas, reinforcing steel shall be fully exposed and concrete shall be removed beyond the reinforcing steel to a depth the greater of 35 mm or 1.5 times the maximum aggregate size contained in the repair material that will be used to carry out the partial depth repair. If deterioration extends beyond this depth the Contractor shall remove concrete to the depth determined by the Consultant.

Exposed reinforcing steel and bonding surfaces shall be ~~sandblasted~~abrasive blasted and the areas blown clean with oil-free compressed air. Reinforcing steel shall be ~~sandblasted~~abrasive blasted to a white metal finish.

~~For~~At partial depth repair areas ~~where~~containing epoxy coated reinforcing steel ~~is exposed~~; the epoxy coating shall be completely removed by ~~sandblasting~~abrasive blasting. The exposed reinforcing bar shall then be protected by the installation of discrete galvanic anodes installed at a minimum of 1 anode per 300 mm of perimeter of the patch area, or the epoxy coating repaired in accordance with the requirements of Section 5, Reinforcing Steel. Galvanic anodes shall be a product selected from those listed on the Alberta Transportation Product List for Galvanic Corrosion Protection. Anodes shall be embedded in a low resistivity mortar and shall have the concrete cover specified on the Drawings, or as determined by the Consultant.

Additional reinforcing steel shall be installed at all locations where the existing reinforcing steel has suffered sectional loss greater than 20%, or as determined by the Consultant. Additional reinforcing steel shall be of the same type used in the original construction or a corrosion resistant reinforcing steel type acceptable to the Consultant. Splicing and/or development requirements will be determined by the Consultant.

~~Additional reinforcing steel shall be installed at all locations where the existing reinforcing steel has suffered sectional loss greater than 20%, or as determined by the Consultant. Additional reinforcing steel shall be of the same type used in the original construction or a corrosion resistant reinforcing steel type acceptable to the Consultant. Splicing and/or development requirements will be determined by the Consultant.~~

Once a prepared area has been accepted by the Consultant and prior to placement of repair material, bonding surfaces shall be saturated with clean water for a minimum of 30 minutes. The area shall be blown free of any surface water immediately prior to placement of the repair material. Repairs shall be trowelled ~~smooth, leveled flush to level with~~ adjacent surfaces, and given the ~~appropriate~~applicable concrete surface finish ~~if applicable~~.

Unless otherwise shown on the Drawings or directed by the Consultant, the Contractor shall re-establish the original design concrete cover at each repair location.

All partial depth repair areas located on the deck surface shall be poured monolithically with placement of deck overlay concrete ~~unless otherwise accepted by the Consultant~~. Other partial depth repair areas shall be formed and recast with ~~an appropriate Alberta Transportation approved~~ concrete patching product, ~~listed in the applicable category on the Alberta Transportation product list~~ extended with aggregates that meet the requirements of CAN/CSA 23.1 or ASTM C33. ~~Concrete patching products that are proposed without the use of aggregates shall be reviewed and accepted by the Consultant and the Department.~~

Where the volume of ~~approved~~ concrete patching product required for an individual partial depth repair area exceeds the volume produced by three 25 kg bags, a rubber paddled mortar mixer of adequate size shall be used for mixing the product. The use of free fall mixers will not be permitted.

Where the repair area is large enough such that placement of ~~an approved~~ concrete patching product becomes impractical, concrete shall be used. Class C concrete shall be used for substructure elements and Class HPC for all other elements. ~~Repair procedures shall be in accordance with Subsection 20.4.3, Full Depth Repair, and the product Manufacturer's recommendations. In the case of conflict, the more stringent requirements shall apply.~~

~~20.4.3 Partial depth repair procedures shall be in accordance with the product Manufacturer's recommendations and this specification. In the case of conflict, the more stringent requirements shall apply and will be determined by the Consultant.~~

~~Partial depth repairs shall be wet cured for a minimum of 7 days. Vertical surfaces of partial depth repairs for substructure elements shall be form cured or wet cured for a minimum of 7 days.~~

~~Partial depth repairs not poured monolithically with the overlay concrete shall be wet cured for a minimum of 7 days or until sufficient strength has been gained such that it is not adversely affected by subsequent placement of the deck overlay as determined by the Consultant.~~

~~Compressive strength testing of concrete patching materials or concrete used for partial depth repairs shall be completed a minimum of each production day, each 0.05 m<sup>3</sup> of material placed or as determined by the Consultant. Compressive strength testing of neat patching products shall be tested in accordance with CSA A3004-C2 or ASTM C109. Compressive strength testing of patching products extended with aggregates or concrete shall be tested by the Contractor in accordance with CSA A23.2-9C or ASTM C39/39M.~~

#### 20.4.3 Full Depth Repair

Where concrete deterioration extends completely through the deck, curbs, or other elements as determined by the Consultant, all unsound concrete shall be removed and replaced with new concrete.

~~Exposed~~ Reinforcing steel and bonding surfaces shall be ~~sandblasted~~abrasive blasted and the areas blown clean with oil-free compressed air. Reinforcing steel shall be ~~sandblasted~~abrasive blasted to a white metal finish.

For repair areas where epoxy coated reinforcing steel ~~is~~are exposed, the epoxy coating shall be completely removed by ~~sandblasting~~abrasive blasting. The exposed reinforcing bar shall then be protected by the installation of discrete galvanic anodes installed at a minimum of 1 anode per 300 mm of perimeter of the repair area, or the epoxy coating repaired in accordance with the requirements of Section 5, Reinforcing Steel. Galvanic anodes shall be a product selected from those listed on the Alberta Transportation Product List for Galvanic Corrosion Protection. Anodes shall be embedded in a low resistivity mortar and shall have the concrete cover specified on the Drawings, or as determined by the Consultant.

Additional reinforcing steel shall be installed at all locations where the existing reinforcing steel has suffered sectional loss greater than 20%, or as determined by the Consultant. Additional reinforcing steel shall be of the same type used in the original construction or a corrosion resistant reinforcing steel type acceptable to the Consultant. Splicing and/or development requirements will be determined by the Consultant.

~~Additional reinforcing steel shall be installed at all locations where the existing reinforcing steel has suffered sectional loss greater than 20%, or as determined by the Consultant. Additional reinforcing steel shall be of the same type used in the original construction or a corrosion resistant reinforcing steel type acceptable to the Consultant. Splicing and/or development requirements will be determined by the Consultant.~~

The underside of the deck, curbs, and other areas requiring full depth repair shall be formed to neatly restore the original lines of the concrete. Forms shall not be hung or suspended from existing deck reinforcing steel.

Once a prepared area has been accepted by the Consultant and prior to concrete placement, bonding surfaces shall be saturated with clean water for a minimum of 30 minutes. The area shall be blown free of any surface water immediately prior to concrete placement. Repairs shall be adequately vibrated, trowelled smooth, leveled flush to adjacent surfaces, and given the applicable concrete finish. Concrete shall be cured in accordance with Subsection 4.23 ~~of~~ Section 4, Cast-In-Place Curing Concrete.

Full depth repairs located on the deck surface shall be recast monolithically with placement of deck overlay concrete. When conditions do not permit a monolithic pour with the deck overlay concrete, full depth repair concrete shall be placed to a depth such that, once the subsequent overlay concrete has been placed, the specified design overlay thickness is achieved.

Full depth repair concrete not poured monolithically with the overlay concrete shall be wet cured for a minimum of 7 days or until it has attained sufficient strength so it is not adversely affected by subsequent placement of the deck overlay as determined by the Consultant.

Class C concrete shall be used to repair substructure elements and Class HPC for all other elements.

Compressive strength ~~test~~testing shall be completed on each batch of concrete placed and in accordance with ~~Subsection 4.9.1 of Section 4, Cast-In-Place Concrete. Concrete shall have 28 day minimum compressive strengths meeting the requirements of Subsection 4.27 of Section 4, Cast-In-Place Concrete, for the applicable Class. The Department reserves the right to reject any concrete that fails to meet the full strength requirements of the Specifications.~~

~~In the event that the strength of any respective concrete batch fails to meet full strength requirements, the Consultant may, in consultation with the Department, accept that batch at reduced payment rates according to the following schedule:~~

<b>28 Day Minimum Compressive Strength</b>	<b>Amount of Payment</b>
Specified strength and over	Full bid price
up to 2 MPa less than the specified strength	Bid price less \$25.00 per square metre
between 2 MPa and 4 MPa less than the specified strength	Bid price less \$50.00 per square metre
between 4 MPa and 5 MPa less than the specified strength	Bid price less \$100.00 per square metre

~~All concrete showing a 28 day minimum compressive strength 5 MPa CSA A23.2-9C or greater below that specified will be rejected ASTM C39/39M.~~

**20.5 ~~20.5~~ Deck Overlay**

20.5.1 ~~20.5.1~~ General

Deck overlay concrete shall be placed as shown on the Drawings; in accordance with the requirements of this specification and ~~Section 4, Cast-in-place Concrete; and as directed~~determined by the Consultant.

20.5.2 ~~20.5.2~~ Concrete

Deck overlay concrete shall be Class HPC or Class HPC with steel fibres, as specified in the Contract.

20.5.3 ~~20.5.3~~ Gradeline Profiles/Dry Run

The gradeline will be designed by the Consultant to provide a smooth riding surface for the finished overlay ~~and transition~~or ACP. The Contractor shall assist the Consultant with profiling of the bridge and approaches prior to and after surface removal. When developing the gradeline profiles, the Consultant will consider such items as rideability, concrete/ACP thickness/quantity, dead load deflection and deck drainage. The design gradeline will be used to determine the overlay thickness and the height of the screed above the existing concrete at each control point.

Gradeline profiles will be produced by the Consultant using the following guidelines:

- ~~Two~~ Two parallel profile lines the entire length of the bridge for each construction stage will be provided as follows:
  - Line No. 1 will be located 1.0 m from curb face.
  - Line No. 2 will be located 0.3 m in from the opposite edge of proposed pour.

The Stations of Line No. 1 and Line No. 2 will be square to each other.

Additional profile lines will be produced when determined by the Consultant.

- ~~Stations~~ Stations will be established at 3.0 m intervals; and at the edges of existing deck joints to be retained and/or at new deck joint locations.
- ~~Profiles~~ Profiles will include 30 m of approach at each end of the bridge at 3.0 m intervals.
- ~~Profile plots~~ Profile plots will be to the following scales:
  - Horizontal: 10 mm = 1 000 mm
  - Vertical: 1 mm (normal) or 1 mm = 5 mm (minimum)
- ~~The proposed design gradeline~~ The proposed design gradeline will be a smooth line achieving a nominal overlay thickness as shown on the Drawings.

Temporary fluorescent paint shall be used to mark profile locations on the existing deck surface, curbs and approaches. The markings shall be approximately 40 mm in diameter. The Contractor shall remove all ~~exposed deck surface temporary~~ markings ~~remaining before overlay placement and all curb and approach temporary markings~~ after the ~~deck overlay~~ Work is complete.

The Consultant will provide the summary of the proposed overlay thickness, to the nearest mm, at each control point prior to the Contractor setting the screed guide rails. The Contractor is responsible for properly setting the screed rails to match the gradeline provided by the Consultant.

Emphasis shall be placed on providing positive longitudinal and transverse drainage from the bridge deck. Depressions in the concrete surface resulting from deficient finishing procedures which may result in ponding water shall be repaired by the Contractor at his expense.

Screed guide rails shall be placed outside the area of concrete placement. The guide rails shall be horizontally and vertically stable. Hold down devices shot into the concrete will not be permitted. The finishing machine and guide rails shall be adjusted so that the height of the screed above the existing concrete at each point conforms to the profile requirements. Guide rails sufficient for the entire contemplated pour shall be set out, adjusted for height, and accepted by the Consultant prior to concrete placement.

To confirm proper adjustment of the machine and guide rails, the screed shall be "dry -run" prior to the pour; and clearance measurements taken at each control point and provided to the Consultant for review and acceptance. ~~Re-setting~~ Resetting of the machine and/or guide rails shall be done as necessary, to provide an acceptable dry -run. Adjustments to the machine or the rails will not be permitted after an acceptable dry -run has been made.

Proposed longitudinal overlay construction joint locations shall be ~~approved by~~ submitted to the Consultant for review and acceptance prior to commencement of ~~overlay construction~~ the Work. Typically, joints shall be located as close to the crown as possible. Where the crown is located at or near a connection joint between two adjacent girders, the longitudinal overlay construction joint shall be offset by a minimum of 300 mm. Longitudinal bulkheads shall be provided at overlay construction joint locations.

---

#### 20.5.4 ~~20.5.4~~ Cement/Silica Fume Slurry Grout

After all ~~deck surface~~ preparation has been completed and accepted by the Consultant, surfaces to be overlaid shall be continuously saturated with clean water for a minimum of 3 hours prior to concrete placement. Immediately prior to the commencement of concrete placement operations, surfaces shall be blown free of all excess water with compressed air, and a cement/silica fume slurry grout applied to enhance the bond between the prepared surfaces and the overlay concrete.

Slurry grout shall consist of 4% silica fume, 46% Type GU hydraulic cement and 50% sand (maximum 2.5 mm aggregate size) by weight, mixed with sufficient water to form a slurry. Slurry grout shall be mixed in a rubber paddled mortar mixer. The consistency of the mixed slurry grout shall be such that ~~it can be applied with a stiff brush or broom to the existing concrete surface without running, does not run~~ or puddling in low spots.

The slurry grout shall be applied in a thin, even coat and worked into prepared surfaces with ~~no puddling~~ stiff bristled floor brushes acceptable to the Consultant. The rate of application shall be controlled to keep pace with the rate of concrete placement, and be limited such that slurry grout is applied immediately ahead of concrete placement. In no case shall the slurry grout be permitted to dry before concrete placement.

Slurry grout shall be continuously mixed to prevent segregation, and applied within 45 minutes of initial mixing. Slurry grout in excess of 45 minutes old ~~will be rejected. The Contractor shall have a minimum of two grout mixers on site during overlay placement~~ shall be removed and replaced at the Contractor's expense.

~~20.5.5 Contractor shall have a minimum of two rubber paddled mortar mixers on site during overlay placement.~~

#### 20.5.5 Conveyance of Concrete on Deck

Generally, vehicles and equipment will not be permitted directly on the prepared bridge deck surface. However, unless otherwise determined by the Consultant and provided the deck surface is continually protected, concrete mixer trucks will be permitted onto the deck to discharge directly ahead of the finishing machine. Deck protection shall consist of plywood, heavy tarps or other protective devices ~~accepted for use by~~ acceptable to the Consultant.

Deck protection shall be sufficient to protect the saturated surface from becoming contaminated with water, oil, spilled concrete and/or other substances. The protection shall remain in place for as long as practicable prior to air blasting and slurry ~~grouting~~ grout placement.

All costs associated with the provision of deck protection necessary for mixer truck access will be considered incidental to the Work, and no separate or additional payment will be made.

#### 20.5.6 ~~20.5.6~~ Mixing Overlay Concrete

Deck overlay concrete shall be mixed at an acceptable concrete batch plant or at the bridge site in mixer trucks. ~~Site batching shall be in accordance with the following requirements:~~

##### 20.5.6.1 Pre ~~u~~-bagging for Site Batching

Fine and coarse aggregates; hydraulic cement; steel fibres, if applicable; fly ash and silica fume shall be measured and pre-mixed together in the ~~approved~~ proportions conforming to the Contractor's reviewed and accepted concrete mix design review letter before being packaged into suitable bags.



Each bag delivered to the site shall be in good condition, free of holes or tears, and with all seams fully sealed. The bags shall be constructed of moisture proof material, and shall be securely closed after filling. The bags shall have adequate lifting hooks or straps attached to the tops, and shall be designed to suitably discharge the material from the bottom of the bag through a discharge opening with a minimum diameter of 460 mm. Each bag shall have a minimum nominal 1 100 kg capacity. Partially filled bags will not be accepted for use on the site.

Materials shall be proportioned by weight. The accuracy of all weighing devices shall be such that successive quantities can be measured to within one percent of the desired amount. As a minimum quantity, 1 100 kg of dry materials, in the correct proportions, shall be mixed together until the materials are fully dispersed before being placed in a bag.

The Department and Consultant shall be given full access to inspect all aspects of the mixing operation; including supply of materials, drying of aggregates, proportioning the constituents, mixing, bagging and storage. The Contractor shall take all precautions necessary to protect the bagged pre-mix from exposure to the elements during hauling and storage at the site.

#### 20.5.6.2 Mixer Trucks and Water Supply for Site Batching

Pre-bagged deck overlay concrete shall be mixed at the bridge site in mixer trucks.

The Contractor shall employ adequate equipment in order to mix concrete at a rate sufficient to ensure continuous concrete placement. A minimum of three mixer trucks shall be brought to the site prior to each overlay pour, and utilized in mixing operations. Mixer trucks shall be revolving drum type, watertight, and constructed so that concrete can be mixed to ensure uniform distribution of materials. Materials for the concrete shall be loaded into the drum at the bridge site.

The Contractor shall provide a suitable water source or tank for the dedicated purpose of batching concrete. The water supply shall have sufficient capacity for each pour. The water supply shall be equipped with an accurate water measuring device calibrated in 0.1 litre increments.

#### Mixing of Deck Overlay Concrete for Site Batching

~~Initially, approximately two thirds of the required~~ The mixing water shall be released into the drum, after which the air entraining agent, superplasticizer procedure and other admixtures shall be added. ~~The remaining required water shall continue to flow into the drum as the solid materials are being loaded into the mixer.~~ sequence, and the mixing time shall be as specified completed in accordance with the requirements of the concrete mix design.

The water supply pipe shall be adequate to ensure that all remaining water addition into the mixer is completed within the first quarter of the mixing time and the outlet situated at a location within the mixer where the water will quickly mix with the entire batch.

The Contractor shall take all steps necessary to ensure that the full content of each pre-mix bag enters the mixer in an even and uniformly proportioned manner. Segregation, spillage and/or other loss of material will not be tolerated. Particular care shall be taken to avoid the loss of cement and silica fume. Batch constituent materials shall be accurately proportioned. Increases in water -cement ratio will not be permitted.

The Contractor shall maintain the mixers in good condition at all times while the Work is being carried out. Inner surfaces of the mixer shall be kept free of hardened concrete and mortar. Mixer blades which are bent or worn to the point that mixing efficiency is affected shall be replaced or refurbished. Mixers leaking mortar or causing waste of materials through faulty charging shall be removed from service until the equipment has been repaired to the satisfaction of the Consultant.

The Contractor shall not load mixers with more than 3 m<sup>3</sup> of concrete or in excess of 85% of its rated capacity, whichever is less. The Contractor shall provide the Manufacturer's certification of the mixing capacity for each machine upon request. Mixers shall only be operated at the speeds recommended by the Manufacturer.

The Contractor shall record the bag production dates/numbers and test the air content, slump, and temperature of each batch at the mixing site. Results of all tests shall be provided to the Consultant. In the case of an unacceptable result, the Contractor will only be allowed to adjust the quantities of superplasticizer and air entraining agent. Adding additional water to the batch will not be permitted. All batch adjustments shall be completed at the batching site and will not be permitted on the deck or at the discharge area. The Department reserves the right to reject any batch in the event of confirmed unacceptability, and to require immediate removal of any concrete from a rejected batch that may have already been placed.

Concrete shall be discharged within 70 minutes after initial introduction of water to the pre-mixed material.

Discharge chutes shall be kept clean, free from hardened concrete, and wetted down prior to use. After each batch is discharged, the drum shall be thoroughly cleaned and excess water removed before a subsequent batch is mixed.

~~20.5.7~~ ~~20.5.7~~ Inspection and Testing

~~Deck overlay concrete~~ Concrete Placement

~~20.5.7.1~~ General

~~Concrete placement~~ shall be carried out, sampled, inspected and tested in accordance with Section Subsection 4, Cast-In-Place Concrete, and the following requirements, 9, Inspection and Testing.

20.5.7.20.5.8 Concrete Placement

20.5.7.120.5.8.1 General

The Contractor shall carry out his concrete placement operations in such a manner that a smooth riding ~~surfaces~~surfaces within the tolerances specified in Section 4, Cast-In-Place Concrete, are achieved.

~~Adequate~~ Lighting shall be provided in front and behind the placing/finishing machine. Additional portable tower ~~lights satisfactory to the Consultant~~light plants shall be placed at each end of the bridge and at the ~~sampling and~~concrete testing area. Details of all proposed lighting and associated equipment shall be submitted as part of the Contractor's deck overlay procedure to the Consultant for review and acceptance.

Concrete shall be placed in such a manner that segregation of materials does not occur. The concrete finishing machine shall meet the requirements of Subsection 4.16.1 ~~of Section 4, Cast-In-Place Concrete, General.~~ Concrete placement shall be carried out in a continuous operation for the duration of the pour. No more than 5 minutes, or period acceptable to the Consultant, shall be allowed to elapse between individual truck mixer discharges. The width of the initial overlay section placed shall extend to the ~~approved~~accepted construction joint location. Subsequent overlay pours shall not be placed until the initial pour has cured a minimum of 72 hours or as determined by the Consultant.

In the event of equipment breakdown and concrete placement for a respective section of bridge is suspended for a period of 60 minutes or more, further concrete placement for the affected section shall be discontinued and shall not resume for a minimum of 12 hours. Notwithstanding this restriction, concrete placement may continue on a subsequent section of the bridge provided a gap sufficient in length for the finishing machine to clear the previously placed concrete is left between the two sections. Prior to continuing concrete placement at a discontinued overlay section, the Contractor shall ~~saw cut~~saw cut a clean, straight vertical edge satisfactory to the Consultant. Material beyond the saw cut shall be removed and disposed of ~~at an approved location.~~ Concrete shall be placed in a gap section between 12 hour and 36 hours after suspension of the pour at the affected section.

~~20.5.7.220.5.8.2~~ 20.5.7.2 Surface Texture

Deck overlay concrete shall receive a Class 6 surface finish when the overlay concrete is the final wearing surface or a Class 4 surface finish where a waterproofing membrane will be applied. Following surface texturing, a 400 mm wide strip of overlay adjacent to the curb shall be ~~trowelled~~troweled smooth and the surface left closed.

At locations where, in the opinion of the Consultant, a satisfactory finish has not been achieved and saw cutting of grooves will achieve the specified surface finish, the Contractor shall saw cut transverse grooves at his expense. Grooves shall be cut to the dimensions ~~described in the Subsection 4.25.7 of~~required for a Class 6 finish as outlined in Section 4, Cast-In-Place Concrete.

~~20.5.7.3~~ 20.5.8.3 ~~20.5.7.3~~ End of Overlay

~~Generally,~~ Concrete overlays ~~will~~shall terminate at a deck ~~joint;~~joints or locations determined by the Consultant. At locations where an overlay does not terminate at a deck joint, ~~such as on roof slabs,~~ the overlay shall be extended for a distance of 150 mm beyond the required end of the overlay to a bulkhead. After adequate curing time, the 150 mm over pour shall be saw cut, ~~and the material removed and disposed of at an approved location, and the remaining surface prepared to the satisfaction of the Consultant for the final specified wearing surface.~~

All costs associated with installation of the bulkhead; saw cutting; and removal and disposal of over pour areas will be considered incidental to the Work, and no separate or additional payment will be made.

~~20.5.7.4~~ 20.5.8.4 ~~20.5.7.4~~ Longitudinal and Transverse Overlay Construction Joints

The Contractor shall construct ~~an~~a bulkhead, acceptable ~~bulkhead~~to the Consultant, at each construction joint location to maintain horizontal and vertical alignments during concrete placing and finishing. The resulting vertical faces of concrete shall be sandblasted as described in Subsection ~~20.3.3.~~ 20.3.3, Deck Surface Abrasive Blasting.

For longitudinal and transverse construction joints, the top edge of the overlay concrete at the ~~faces of curbs, barriers, medians, previously placed overlay concrete,~~bulkhead and/or existing concrete shall be tooled to a depth of 12 mm and a width of ~~63~~ mm. Tooled grooves shall ~~then~~ be filled with a proven epoxy resin type gravity flow concrete crack filler listed on the Alberta Transportation Product List.

Prior to epoxy application, the grooves shall be blown clean to remove all deleterious materials and the concrete contact surfaces prepared in accordance with the epoxy Manufacturer's recommendations. Tooled grooves shall be completely filled with epoxy material to a level equal to the adjacent concrete; ~~and may require~~ multiple applications of epoxy ~~may be required.~~

All costs associated with constructing longitudinal and transverse overlay construction joints including ~~sandblasting~~abrasive blasting, groove tooling, and application of gravity flow epoxy crack filler will be considered incidental to the Work, and no separate or additional payment will be made.

~~20.5.7.5~~ 20.5.8.5 ~~20.5.7.5~~ Curing Concrete

Curing of overlay concrete shall be in accordance with Subsection 4.23.3 ~~of Section 4, Cast-In-Place Concrete,~~ Curing Requirements for Class HPC and Class HPC with Steel Fibres.

If, in the opinion of the Consultant, the Contractor's wet curing procedures are deemed deficient in any way and/or any portion of the overlay becomes surface dry during the curing period, the overlay may be rejected.

~~20.5.7.6~~ 20.5.8.6 ~~20.5.7.6~~ Application of Sealer

The Contractor shall supply and apply a Type 1c sealer to all areas where a Class 6 surface finish has been applied and along ~~trowelled~~ troweled gutter areas. Sealer shall be applied once the concrete has cured for a minimum of 14 days.

Sealer shall be applied in accordance with Subsection 4.26 ~~of Section 4, Cast-In-Place Concrete, Type 1c Sealer.~~ In the event the deck overlay concrete surface becomes contaminated with dirt, debris or other deleterious material prior to sealer application, the Contractor shall clean the affected areas to the satisfaction of the Consultant.

All costs associated with the supply and application of sealer to deck overlay areas, including cleaning as required, will be considered incidental to the Work, and no separate or additional payment will be made.

~~20.5.7.7~~ 20.5.8.7 ~~20.5.7.7~~ Opening to Traffic

The concrete overlay shall not be opened to traffic until the concrete has been cured in accordance with Subsection ~~20.5.7.5~~ 20.5.8.5, Curing Concrete, and has reached a minimum strength of 35 MPa.

**20.6** ~~20.6~~ **Measurement and Payment**

20.6.1 ~~20.6.1~~ Surface Removal

Measurement for payment of surface removal will be by the square metre ~~of surface acceptably removed, measured, based on horizontal measurements~~ to the nearest 0.1 m<sup>2</sup>.

Payment will be made at the unit price bid for “Surface Removal” of the type specified, and will be full compensation for removal of the existing wearing surface (s) and/or concrete to the depths specified; deck surface cleaning; disposal of debris; and all labour, equipment, tools and incidentals necessary to complete the Work to the satisfaction of the Consultant.

20.6.2 ~~20.6.2~~ Partial and Full Depth Repairs

Measurement for payment of partial and full depth repair areas will be by the square metre of concrete acceptably repaired, regardless of depth, measured to the nearest ~~0.4~~ 0.1 m<sup>2</sup>.

Payment will be made at the unit prices bid for “Partial Depth Repair” or “Full Depth Repair” as applicable, for the locations identified. ~~Payments, less any applicable payment adjustments for compressive strength, and~~ will be full compensation for the containment and removal of ~~unsound~~ concrete; ~~sandblasting~~ abrasive blasting; disposal of debris; the supply and installation of additional reinforcing steel where required; epoxy coated reinforcing steel coating ~~repair and/or the supply and installation of galvanic anodes as repairs where~~ required; provision and removal of all ~~forming~~ formwork, scaffolding and falsework; repair material supply, placement and testing; and all labour, materials, equipment, tools and incidentals to complete the Work to the satisfaction of the Consultant.

~~Where concrete is used for repairs, it will be subject to strength requirement testing and penalty assessment described in Subsection 20.4.3, Full Depth Repair.~~

**20.6.3—Deck Sandblasting**

~~80% of the unit price bid will be paid once the repair materials have been acceptably placed and the 7 day concrete compressive strength tests indicate, in the opinion of the Consultant, that the repair materials will achieve the specified strength. Initial payment will not constitute full acceptance of the repair. The remaining 20% of the unit price bid will be made once surface finishing, as applicable, has been acceptably completed, and the 28 day compressive strength test results have been reviewed and accepted by the Consultant.~~

~~The Department reserves the right to reject repair materials that do not meet the specified requirements. The Department may, at its sole discretion, accept repairs that do not meet the specified 28 day concrete compressive strength at a reduced price. Payment adjustment may be made in accordance with Table 20-1: Payment Adjustment Schedule.~~

**Table 20-1: Payment Adjustment Schedule**

<b><u>28 Day Minimum Compressive Strength</u></b>	<b><u>Payment Adjustment</u></b>
<u>Equal to or greater than the specified strength</u>	<u>Full bid price</u>
<u>up to 2 MPa less than the specified strength</u>	<u>Bid price less \$50.00 per square metre</u>
<u>between 2 MPa and 4 MPa less than the specified strength</u>	<u>Bid price less \$100.00 per square metre</u>
<u>between 4 MPa and 5 MPa less than the specified strength</u>	<u>Bid price less \$250.00 per square metre</u>
<u>more than 5 MPa less than the specified strength</u>	<u>Rejected</u>

**20.6.3 Deck Surface Abrasive Blasting**

Measurement for payment of deck surface ~~sandblasting~~abrasive blasting will be by the square metre of ~~horizontal bridge deck surface acceptably treated, measured~~prepared based on horizontal measurements to the nearest 0.1 m<sup>2</sup>. ~~No allowance will be made for required sandblasting of the vertical faces~~ Vertical surfaces of curbs, ~~medians and barriers~~ and medians will not be measured.

Payment will be made at the unit price bid for "Sandblasting—Bridge Abrasive Blasting – Deck, Surface", and will be full compensation for ~~sandblasting~~abrasive blasting; cleaning of ~~the sandblasted area, including~~blasted areas; disposal of debris; and all labour, materials, equipment, tools and incidentals necessary to complete the Work to the satisfaction of the Consultant.

20.6.4 All cost associated with deck surface abrasive blasting of vertical surfaces will be considered incidental to the Work, and no separate or additional payment will be made.

#### 20.6.4 Deck Overlay Concrete

##### 20.6.2.1 20.6.4.1 Supply of Deck Overlay Concrete

Measurement for ~~the~~payment for supply of deck overlay concrete will be by the cubic metre of ~~acceptable overlay concrete~~ accepted, placed, and remaining in the ~~completed work,~~ calculated~~Work; measured~~ to the nearest 0.401 m<sup>3</sup>.

The ~~cubic metre~~quantity of concrete to be paid for will be calculated by the Consultant ~~from using the final "accepted dry -run" values and the surface~~ area overlaid. ~~Concrete overpour~~Over pour concrete will not be ~~included in the quantity calculation~~paid for.

Payment will be made at the unit price bid for ~~"Deck Overlay Concrete -- Supply",~~ less any applicable payment adjustments for compressive strength, and will be full compensation for ~~supplying the supply and delivery of the concrete to the bridge site from batch plants or by site batching; including; sampling, inspection and testing; and~~ all labour, ~~materials,~~ equipment, tools and incidentals necessary to complete the Work to the satisfaction of the Consultant.

The Department reserves the right to reject concrete that does not meet the specified requirements. The Department may, at its sole discretion, accept concrete that does not meet the specified 28 day concrete compressive strength at a reduced price. Payment adjustment may be made in accordance with Subsection 4.27.1.1, Compressive Strength Test Result Payment Adjustment.

80% of the unit price bid will be paid once the concrete has been acceptably placed and the 7 day concrete compressive strength tests indicate, in the opinion of the Consultant, that the concrete will achieve the specified strength. Initial payment will not constitute full acceptance of the concrete. The remaining 20% of the unit price bid will be made once the concrete surface finishing and concrete sealer application has been acceptably completed, and the 28 day compressive strength test results have been reviewed and accepted by the Consultant.

##### 20.6.4.2 Placement of Deck Overlay Concrete

Measurement for payment for the placement of deck overlay concrete will be by the square metre of concrete ~~acceptably~~accepted, placed and remaining in the ~~structure~~Work, measured to the nearest 0.1 m<sup>2</sup>.

Payment will be made at the unit price bid for ~~"Deck Overlay Concrete -- Place",~~ and will be full compensation for ~~the falsework and formwork;~~ supply and application of water for surface saturation; the supply and application of slurry grout; concrete placement; surface finishing and curing; the supply and application of concrete sealers; and all labour, equipment, tools and incidentals to complete the Work to the satisfaction of the Consultant.

~~Concrete overlay failing to meet the 28 day minimum compressive strength requirement of 45 MPa is subject to payment adjustment as described in Subsection 4.26 of Section 4, Cast-In-Place Concrete.~~

80% of the unit price bid will be paid once the concrete has been acceptably placed and the 7 day concrete compressive strength tests indicate, in the opinion of the Consultant, that the concrete will achieve the specified strength. Initial payment will not constitute full acceptance of the placement. The remaining 20% of the unit price bid will be made once the concrete surface finishing and concrete sealer application has been acceptably completed, and the 28 day compressive strength test results have been reviewed and accepted by the Consultant.

The Department reserves the right to reject the concrete placement where the supply or placement of deck overlay concrete does not meet the specified requirements.

All costs associated with concreting in cold weather, when required, will be considered incidental to the Work, and no separate or additional payment will be made.



STANDARD SPECIFICATIONS FOR BRIDGE CONSTRUCTION

**SECTION 21 DEMOLITION, DISPOSAL AND SALVAGE OF BRIDGE STRUCTURES**

TABLE OF CONTENTS

<b>21.1</b>	<b>General</b>	<b>21-1</b>
<b>21.2</b>	<b>Demolition and Disposal</b>	<b>21-1</b>
21.2.1	General	21-1
21.2.2	Excavation	21-2
21.2.3	Site Restoration	21-3
<b>21.3</b>	<b>Salvage</b>	<b>21-3</b>
<b>21.4</b>	<b>Measurement and Payment</b>	<b>21-4</b>
21.4.1	Demolition and Disposal of Existing Bridge Structures	21-4
21.4.2	Salvage of Existing Bridge Materials	21-5



## 21.1 General

This specification ~~covers materials and related works is~~ for the removal, demolition, disposal and salvage of bridge structures ~~and bridge culverts. This includes salvage and disposal of materials from these bridge structures.~~

The Work shall be completed in accordance with this specification or the Contract and as determined by the Department and the Consultant.

All Existing bridge structure materials in bridge structures are the property of the Department. Prior

References to removal of bridge structures the Contractor within this specification shall obtain, from the Consultant, a list of also apply to culverts.

Materials to be salvaged and permission to proceed. Treated timber, structural steel, corrugated steel pipes and precast concrete units may be considered for salvage and when required will be specified in the Special Provisions of the Contract. The location and haul requirements associated with salvaged bridge structures and/or materials will also be specified in the Special Provisions of the Contract.

## **21.2 21.2 Workmanship Demolition and Handling of Materials Disposal**

### 21.2.1 General

The Contractor shall remove the bridge structure including soil and foundations in accordance with the Contract, these specifications and as determined by the Department and the Consultant.

A construction milestone meeting shall be scheduled by the Contractor for demolition, disposal and salvage Work. A construction milestone meeting will not be required for the demolition, disposal and salvage of culverts. The Contractor's project manager, field superintendent, and any specialty Subcontractors shall attend the construction milestone meeting at a location determined by the Consultant.

Unless otherwise specified in the Special Provisions of the Contract, the Contractor shall submit a detailed demolition and disposal plan to the Consultant for review and acceptance a minimum of 2 weeks prior to scheduling the construction milestone meeting. The demolition and disposal plan shall be prepared, signed and sealed by a Professional Engineer registered in the Province of Alberta include drawings and supporting documents necessary to describe the following:

- Traffic Accommodation Strategy (TAS);
- Access to work, earth berms and work bridges;
- Temporary works and support structures including stabilizing details and measures;
- Type and capacity of equipment;

- Sequence of operation including position of cranes;
- Position of cranes relative to substructure elements such as abutment backwalls, with details of load distribution of wheels and outriggers;
- Lifting devices and lifting points showing lifting forces;
- Demolition sequence;
- Updated ECO plan to address all environment regulations and Contract requirements;
- Permitting approvals from regulatory authorities;
- Proposed disposal procedures and disposal locations;
- Temporary supporting structures removal; and
- Site restoration.

Safety and compliance with the Occupational Health and Safety Act and Regulations thereunder, shall be an integral part of the design of the demolition and disposal plan.

The Contractor shall continue to be fully responsible for the results obtained by the use of demolition and disposal plan, with the Professional Engineer also assuming responsibility, as the Contractor's Agent, for the results obtained.

The Consultant's review and acceptance shall not be considered as relieving the Contractor of the responsibility for the safety of his methods or equipment, nor from completing the Work in accordance with his demolition and disposal plan and these specifications. The Contractor shall not commence any Work until review and acceptance of the demolition and disposal plan by the Consultant has been obtained.

The extent of bridge structure removal, including excavation, shall be to an elevation of 0.6 metres below streambed for bridge piers and 1.0 m below existing ground for bridge abutments and all other bridge elements, unless otherwise specified in the Special Provisions of the Contract.

The extent of culvert removal, including excavation, shall be to the invert elevation for a width of the culvert plus 1.5 metres on either side.

#### 21.2.2 Excavation

Excavation required for the removal of bridge structures shall be completed in accordance with Section 1, Excavation.

### 21.2.3 Site Restoration

Upon completion of the demolition, disposal and salvage of bridge structures, the Contractor shall restore the site to a condition similar to the natural ground, and as determined by the Consultant. This shall include disposing of all surplus excavated materials, backfilling as required, supplying and placement of 50 mm minimum thickness of organic material on all disturbed areas and seeding.

The Contractor shall restore excavated areas to the grade shown on the Drawings, in accordance with Section 2, Backfill and as determined by the Consultant.

### 21.3 Salvage

The Contractor shall perform his Work in a manner that prevents damage to or loss of bridge structures and/or materials listed for salvage. Where the Contractor causes damage to or loss of bridge structures and/or materials listed for salvage, the Contractor shall repair or replace these bridge structures and/or materials at his expense and to the acceptancesatisfaction of the Consultant and the Department.

### ~~21.3 Excavation for Removal~~

~~Excavation shall conform to Section 1 – Excavation.~~

~~For culverts, the excavation shall extend to the invert elevation and the width at this level shall be the culvert width plus 3.0 m. For bridge abutments, the excavation shall extend to the ground level at the front of the abutment. The sides of all excavations shall be excavated at one horizontal to one vertical or as required for stability.~~

### ~~21.4 Removal~~

#### ~~21.4.1 General~~

~~Removal shall mean removing bridge structures, salvaging the materials listed by the Consultant, stockpiling the salvaged materials at the bridge site or the Contractor's storage area, disposing of the remainder of the bridge structure and leaving all work areas in a tidy and safe condition.~~

~~The Contractor shall provide the Consultant with a list of all materials that were salvaged.~~

#### ~~21.4.2 Salvage~~

~~Materials listed by the Consultant for salvage shall be dismantled piece by piece removing all nails, bolts, drift pins and other hardware. Torch cutting to remove hardware or to dismantle these bridge structures and/or materials identified for salvage will not be permitted.~~

Structural plate corrugated steel Pipespipe culverts shall be dismantled to yieldachieve lengths not exceeding eight8 metres. Corrugated steel Pipespipe culverts shall be dismantled by removing the couplers to achieve the original fabricated lengths.

Precast concrete units shall be individually removed after disconnecting the units by removing the grout from shear keys and connector pockets, ~~and by removing~~ connector bolts, drift pins and other hardware. Precast concrete units shall be lifted only at the designed lifting points, with the top of each unit up at all times, and shall be allowed to rest only on the designed bearing areas.

#### ~~21.4.3 Disposal~~

~~Materials in bridge structures not listed for salvage shall be disposed of in a manner and location acceptable to the Consultant. The Contractor shall provide written acceptance from the owners of the disposal site(s) and evidence of their acceptance of the disposal site clean up, prior to receiving full payment.~~

~~In general, the portion of bridge abutments and piers located above natural ground level shall be completely removed, and the portion 1 metre below the natural ground level may remain in place.~~

#### ~~21.5 Haul of Bridge Material~~

~~When determined by the Consultant, the Contractor shall haul/transport salvaged bridge structures and/or materials. The haul of to the location designated in the Special Provisions of the Contract and in a manner that does not damage the salvaged bridge structures and/or materials shall include loading, unloading, stockpiling and all associated handling of the materials in any way.~~

#### ~~21.6 Measurement and Payment~~

#### ~~21.4 Payment~~

##### ~~21.4.1 Demolition and Disposal of Existing Bridge Structures~~

~~Payment for **Removal**the demolition, removal and disposal of existing bridge structures will be made at the lump sum bid/price bid for "Demolition and Disposal of Bridge Structure" for the particulars specified bridge structure removed. This payment will be full compensation for completing the work as described in section 21.4 including excavation, and for the use of all equipment, tools, labour will be full compensation for demolition of the structure; breaking down, loading, hauling and disposing of debris at a location acceptable to the Consultant; and all labour, equipment, tools and incidentals necessary to complete the Work to the satisfaction of the Consultant.~~

##### ~~21.6.1 Haul of Bridge Material~~

~~Haul of Bridge Material will be made only where the Consultant directs the Contractor to undertake the haul of salvaged material to a point outside the limits of the contract and only when the Consultant accepts the condition of the salvaged material at the final location. The haul of salvaged material to the Contractor's storage area, and haul of material to a disposal site will not be paid for separately but will be considered incidental to the removal of the bridge structures.~~

Where applicable, payment for the **Haul of Bridge Material** outside the limits of the contract. The Contractor shall provide the Consultant with written acceptance of the materials from the owner of the disposal site before payment for this Work will be made.

50% of the lump sum price bid will be paid once the removal and disposal of the superstructure and abutments has been acceptably completed. The remaining 50% of the lump sum price bid will be made once all substructure components have been removed to the extent required, and the site has been restored to a condition acceptable to the Consultant and the Department.

#### 21.4.2 Salvage of Existing Bridge Materials

Payment for the removal and salvage of designated bridge structure materials will be made at the lump sum price bid ~~which price shall include~~ for “Salvage of Existing Bridge Materials”, and will be full compensation for the removal and salvage of specified materials; loading, hauling, unloading, and stockpiling and for providing of the materials at the designated storage site(s); and all labour, equipment, tools and incidentals necessary to complete the Work- to the satisfaction of the Consultant.





# STANDARD SPECIFICATIONS FOR BRIDGE CONSTRUCTION

## SECTION 22 PAINTING

### TABLE OF CONTENTS

<b>22.1</b>	<b>General</b>	<b>22-1</b>
<b>22.2</b>	<b>Standards</b>	<b>22-1</b>
<b>22.3</b>	<b>Contractor Qualifications</b>	<b>22-2</b>
<b>22.4</b>	<b>Materials</b>	<b>22-2</b>
22.4.1	Supply	22-2
22.4.2	Blasting Media	22-2
22.4.3	Paint	22-3
<b>22.5</b>	<b>Environmental Considerations</b>	<b>22-4</b>
22.5.1	Emission Levels	22-4
22.5.2	Environmental Regulations	22-4
22.5.3	Fish Habitat	22-5
22.5.4	Blasting Spoil Recovery	22-5
22.5.5	Protection of Property	22-5
22.5.6	Quality Assurance	22-5
22.5.7	Background Contamination Levels	22-5
<b>22.6</b>	<b>Permits, Licences and Approvals</b>	<b>22-6</b>
<b>22.7</b>	<b>Work Proposal</b>	<b>22-6</b>
<b>22.8</b>	<b>Work Site Health and Safety</b>	<b>22-7</b>
<b>22.9</b>	<b>Bridge Load Evaluation Report</b>	<b>22-7</b>
<b>22.10</b>	<b>Protection of Surfaces</b>	<b>22-9</b>
<b>22.11</b>	<b>Areas Not To Be Painted</b>	<b>22-10</b>
<b>22.12</b>	<b>Work Execution</b>	<b>22-10</b>
22.12.1	Temporary Attachments	22-10
22.12.2	Containment System	22-10
22.12.3	Containment System Monitoring	22-11
22.12.3.1	Abrasive Blasting	22-11
22.12.3.2	Water Blasting	22-12
22.12.4	Ventilation System	22-12
22.12.5	Assessing Emissions	22-12
<b>22.13</b>	<b>Surface Cleaning</b>	<b>22-13</b>
<b>22.14</b>	<b>Surface Preparation</b>	<b>22-13</b>
22.14.1	Abrasive Blast Cleaning	22-13

<b>22.15</b>	<b>Pack Rust.....</b>	<b>22-14</b>
<b>22.16</b>	<b>Disposal of Blasting Spoil .....</b>	<b>22-15</b>
<b>22.17</b>	<b>Priming and Painting.....</b>	<b>22-15</b>
22.17.1	Stripe Painting.....	22-15
22.17.2	Paint Application .....	22-15
<b>22.18</b>	<b>Quality Control .....</b>	<b>22-17</b>
<b>22.19</b>	<b>Authority of the Consultant .....</b>	<b>22-17</b>
<b>22.20</b>	<b>Acceptance .....</b>	<b>22-17</b>
<b>22.21</b>	<b>Repair .....</b>	<b>22-18</b>
<b>22.22</b>	<b>Site Clean-Up.....</b>	<b>22-18</b>
<b>22.23</b>	<b>5 Year Bridge Painting Warranty .....</b>	<b>22-18</b>
<b>22.24</b>	<b>Shop Coating of Structural Steel for Bridges.....</b>	<b>22-20</b>
22.24.1	Fabrication Paint Shop.....	22-20
22.24.2	Pre-Surface Preparation.....	22-20
22.24.3	Abrasives .....	22-20
22.24.4	Blast Cleaning.....	22-21
22.24.5	Masking .....	22-21
22.24.6	Paint.....	22-21
22.24.7	Paint Application .....	22-21
22.24.8	Intercoat Cleanliness.....	22-21
22.24.9	Recoat Time.....	22-21
22.24.10	Shipping Inspection.....	22-21
22.24.11	Shipping .....	22-22
<b>22.25</b>	<b>Measurement and Payment .....</b>	<b>22-22</b>
22.25.1	Protection of the Environment .....	22-22
22.25.1.1	General.....	22-22
22.25.1.2	Payment by Unit Price.....	22-22
22.25.1.3	Payment by Lump Sum.....	22-23
22.25.2	Surface Preparation and Painting.....	22-23
22.25.2.1	Estimated Surface Area .....	22-24
22.25.2.2	Payment .....	22-24

## 22.1 General

This specification is for field painting of structural steel bridges and for shop painting of newly fabricated structural steel for bridges.

Where Standards and Standard Specifications are referenced, the version current at the time of tendering shall govern, unless a specific date is described. Metric versions are inferred, when available and relevant.

This specification describes requirements for several different methods of preparation and for several different approved coating systems which may be applied to bridge structures. Each painting contract shall have Special Provisions and/or Drawings which delineate the applicable area of the structure and the coating system to be applied to it.

## 22.2 ~~22.2~~ Standards

- ~~————~~ Society for Protective Coatings (SSPC) “Standard Procedure for Evaluating the Qualifications of Painting Contractors” SSPC-QP1.
- ~~————~~ SSPC “Standard Procedure for Evaluating the Qualifications of Painting Contractors to Remove Hazardous Paint” SSPC-QP2
- ~~————~~ SSPC Guide 6-Guide for Containing Debris Generated During Paint Removal Operations.
- ~~————~~ SSPC SP 1 Solvent Cleaning.
- ~~————~~ SSPC SP 2 Hand Tool Cleaning.
- ~~————~~ SSPC SP 3 Power Tool Cleaning.
- ~~————~~ SSPC SP 5 White Metal Blast Cleaning.
- ~~————~~ SSPC SP 6 Commercial Blast Cleaning.
- ~~————~~ SSPC SP 7 Brush-Off Blast Cleaning.
- ~~————~~ SSPC SP 10 Near-White Blast Cleaning.
- ~~————~~ SSPC SP 12 Surface Preparation and Cleaning of Steel and Other Hard Materials by High- and Ultrahigh-Pressure Water Jetting Prior to Re-coating.
- ~~————~~ SSPC AB1 Mineral and Slag Abrasives.
- ~~————~~ SSPC AB2 Cleanliness of Recycled Ferrous Metallic Abrasives.
- ~~————~~ SSPC AB3 Newly Manufactured or Re-Manufactured Steel Abrasives.
- ~~————~~ SSPC PA Guide No.11 Protecting Edges, Crevices, and Irregular Steel Surfaces by Stripe Coating
- ~~————~~ SSPC PA 2 Measurement of Dry Coating Thickness with Magnetic Gauges
  
- ~~————~~ Alberta Transportation “Fish Habitat Manual”
- Alberta Transportation “Bridge Load Evaluation Manual”

SSPC specifications are available at <http://www.sspc.org>~~http://www.sspc.org~~

Alberta Transportation Product List – Approved Products “Bridge Coating Systems – Paint” available on the Department’s website at:

<http://www.transportation.alberta.ca/Content/docType253/Production/paintlist.pdf>

~~22.3~~—<http://www.transportation.alberta.ca/Content/docType253/Production/paintlist.pdf>

### 22.3 Contractor Qualifications

One of the following four competency levels will be specified in the Special Provisions of the Contract.

CQ1 The Contractor or painting subcontractor must have certification in good standing with the Society for Protective Coatings (SSPC) under SSPC-QP2.

CQ2 The Contractor or painting subcontractor must have certification in good standing with the Society for Protective Coatings (SSPC) under SSPC-QP1.

CQ3 The Contractor or painting subcontractor acceptance will be based on submission of documented experience which should include but not be limited to: the names of owners, projects and dates of previous bridge painting projects where containment and disposal of blasting spoil was practised/implemented, copies of any relevant environmental permits and any citations for failure to comply. A list of qualified personnel responsible for the actual paint removal and application will be required. Once accepted no personnel changes shall be made without the Consultant’s written acceptance. Permission for the Consultant to interview the owners, environmental departments and personnel listed above. Falsifying information in the submission will be grounds for disqualification of the bid.

CQ4 No specific pre-qualification requirements.

Only Contractors having the specified level of competency, at the time of tender closing ~~tenders~~ will be considered acceptable.

### 22.4 ~~22.4~~ Materials

#### 22.4.1 ~~22.4.1~~ Supply

The Contractor or painting subcontractor shall supply all materials to satisfactorily complete the work.

#### 22.4.2 ~~22.4.2~~ Blasting Media

Contractors may choose the type of abrasive intended for use, taking into consideration the abrasive disposal and worker's health implications of each type. The abrasive selected shall comply with the applicable Society for Protective Coatings (SSPC) standard.

Blasting grit shall be free of corrosion producing contaminants and shall be free of any moisture, oils, greases or other elements which will reduce the adhesion of paint coatings. The blast cleaning abrasive used shall produce the minimum surface profile required by the paint manufacturer.

The use of pre-treatment coatings, blasting media additives or treatment of blasting spoil prior to, or subsequent to, disposal must be reviewed and accepted by the Department and Consultant.

22.4.3 ~~22.4.3~~ Paint

The Contractor shall select an approved product from the Alberta Transportation Product List – Approved Products “Bridge Coating Systems – Paint”. The paint system shall be from the category specified in the Special Provisions: of the Contract. The material data sheets and material safety data sheets of the chosen paint system shall be submitted with the Contractor’s work proposal. A single paint system shall be used throughout the entire project unless specified otherwise. The Contractor shall not change to another paint system once the initial paint system has been applied to any portion of the structure.

The paint shall be delivered in sealed, original, labelled containers bearing the Manufacturer’s name, type of paint, brand name, colour designation, batch number and instructions for mixing and/or reducing.

For each batch of paint used on the project, the Contractor shall have an independent laboratory carry out quality control tests for colour, gloss and formulation. The results shall be submitted to the Consultant for review and acceptance a minimum two weeks prior to the anticipated commencement of painting operations. No paint shall be applied to the structure prior to acceptance of the test results by the Consultant and Department.

Colour testing for the mixed top coat shall be carried out in accordance with ASTM D2244 with a CIE 1976 L\*A\*B, 2 degree observer, and a D65 illuminate.

Gloss testing for the mixed top coat shall be carried out in accordance with ASTM D523 at 60 degrees.

Infrared Spectroscopy (IR) shall be conducted on all individual components of the paint system prior to mixing, to confirm that the formulation conforms to that which was originally approved. A minimum 32 scans shall be taken with a Fourier transform infrared spectrometer between 4000 and 400 wave-numbers (CM-1) using the salt plate sandwich technique. The salt plate may be made from potassium bromide for non-aqueous paints. If the formulation contains water; appropriate, non-water soluble plates shall be used. Plate material shall be reported with each individual spectrum. The spectra shall be taken of vehicle portion of the coating without the pigment. For single component materials, a representative sample of the material shall be centrifuged to remove pigment and then analyzed. For plural component materials, each of the individual components shall be centrifuged to remove pigment and then analyzed separately. IR analysis of the mixed components is not required. The IR plots shall be completed with transmittance (0 – 100%) on the y-axis and Wave-numbers (4000 – 400; non-linear) on the x-axis. All peaks shall be labelled with the corresponding wave-number. The spectra shall be taken such that the largest peaks are at 50 – 0%T and the baseline is greater than 80%T. Materials with IR plots indicating a change in formulation from that which was originally approved will be rejected.

Each batch of paint may be subjected to additional testing by the Department or Consultant.

If requested, the Contractor shall provide four – 250 ml samples of paint from a pail or barrel chosen by the Department or Consultant. Samples shall be placed in suitable new, clean, metal containers; and sealed to avoid contamination of the paint.

## **22.5**     ~~22.5~~ Environmental Considerations

### 22.5.1     ~~22.5.1~~ Emission Levels

The percentage of blasting spoil that must be recovered and the Class of containment required shall be as specified in the ~~contract~~ Special Provisions of the Contract and detailed in the SSPC-Guide 6.

Monitoring and acceptance criteria described in ~~section~~Subsection 5.5 of the SSPC-Guide 6, methods A to F, to monitor the quantity of emissions escaping the enclosure shall be specified in the contract Special Provisions of the Contract.

### 22.5.2     ~~22.5.2~~ Environmental Regulations

The Contractor shall ensure that existing paint being removed, and any abrasive material used to accomplish the removal, is contained and properly and safely disposed of in accordance with the applicable laws and regulations.

The Contractor shall comply with all Federal, Provincial, and Municipal, air, soil and water ~~pollution~~contamination control regulations, when cleaning and repainting the structural steel and when disposing of any waste generated. These specifications set forth minimum requirements necessary to protect the environment. The Contractor shall perform additional work to modify containment or disposal procedures to ensure compliance with all applicable laws and regulations.

---

### 22.5.3 ~~22.5.3~~ — Fish Habitat

When working on structures over water inhabited by fish the Contractor shall conform to the requirements of the Alberta Transportation “Fish Habitat Manual”. This manual is available on the internet at:

[http://www.transportation.alberta.ca/Content/docType245/Production/Complete\\_Fish\\_Habitat\\_Manual.pdf](http://www.transportation.alberta.ca/Content/docType245/Production/Complete_Fish_Habitat_Manual.pdf)

### 22.5.4 ~~22.5.4~~ — Blasting Spoil Recovery

The containment system for the blast cleaning and painting shall be installed such that the minimum specified percentage of the blast spoil and paint removed, as listed in the Special Provisions of the Contract, is contained.

### 22.5.5 ~~22.5.5~~ — Protection of Property

During cleaning and painting procedures, the Contractor shall take necessary precautions to fully protect the environment, the workers, traffic, parked vehicles, adjacent property, and other portions of the structures from damage caused by cleaning debris, blast cleaning materials, dirt, dust, equipment oils, solvents, acids, burning matter and paint drifts, drops, or spray and spatter.

### 22.5.6 ~~22.5.6~~ — Quality Assurance

An Environmental Auditor may be retained by the Consultant to assure compliance with the requirements of the Environmental Permits and/or Screening Report and to monitor the performance of the containment system in particular and that of the Contractor in general.

### ~~22.5.7~~ — Background Contamination Levels

#### ~~22.5.7~~ Pollution

Contamination of the environment shall be minimized at all times during the Work. The Contractor’s operations may also be monitored by other agencies.

The Contractor shall identify locations in which to establish background soil, water/snow, and air contamination levels in his work proposal. After the Contractor’s work proposal has been reviewed and accepted by the Consultant and prior to commencement of the work, the Contractor shall collect soil, water/snow, and air samples from the project site for analysis. Samples shall be collected in the presence of the Consultant and at locations most likely affected by the work, such as at the dust collector, recycling unit, key points along the spoil material transfer lines, and spoil material storage areas. As a minimum, three samples shall be collected at each location and sent to an accredited laboratory approved by the Consultant for analysis. Analysis shall be consistent with regulatory reporting requirements and results submitted to the Consultant.

The Consultant may require the Contractor to collect additional soil, water/snow, and air samples at the site for analysis during the course of the work if contamination is suspected. If requested, the Contractor shall immediately collect samples and have ~~them~~they analyzed at the approved laboratory. Results shall be forwarded to the Consultant within one week of collecting the samples.

The Contractor shall collect samples at all established background locations once painting operations are completed and equipment is removed from the site. As a minimum, two post construction composition tests shall be completed at each background location and results submitted to the Consultant for review and acceptance. Analysis shall be performed at the approved laboratory using the same test methods used for initial background analysis. If post construction analyses show that the Contractor's work has adversely affected the environment, site remediation will be required and shall be carried out to the full satisfaction of the Department and the Consultant.

All cost associated with soil, water/snow, and air sampling including any subsequent site remediation requirements will be considered incidental to the Work and no separate or additional payment will be made.

## **22.6 ~~22.6~~ Permits, Licences and Approvals**

The Contractor shall obtain the necessary permits, licences and approvals, and conform to all requirements of Environmental Screening Reports, Municipal bylaws, Provincial and Federal Environmental Protection laws, for all work carried out. The Contractor shall be familiar with and comply with all regulations, such as, but not limited to, Environmental permits, the Worker's Compensation Act, the Occupational Health and Safety Act, Regulation and Code which control the exposure of workers to chemical hazards.

## **22.7 ~~22.7~~ Work Proposal**

The Contractor shall submit his work proposal to the Consultant for review and acceptance a minimum of two weeks prior to the pre-construction meeting. The work proposal shall include, but not be limited to:

- Schedule<sub>i</sub>
- Sequence of operations<sub>i</sub>
- Traffic accommodation strategy<sub>i</sub>
- Site lay down plan including placement of equipment<sub>i</sub>
- Proposed sampling locations for establishment of background contamination levels<sub>i</sub>
- ~~Bridge washing~~Surface cleaning strategy<sub>i</sub>
- Storage, handling and disposal of new and contaminated blasting material<sub>i</sub>
- Methods of weighing blasting material on and off the project<sub>i</sub>
- Method of separating hazardous and ~~non-hazardous~~nonhazardous blasting spoil<sub>i</sub>
- Sample documentation for tracking the disposal of hazardous waste<sub>i</sub>
- The final destination of hazardous waste<sub>i</sub>
- Chosen coating system from the Alberta Transportation Product List - Approved Products "Bridge Coating Systems (Paint)<sub>i</sub>": and



- Bridge Load Evaluation Report.

### ~~22.8~~ 22.1 Bridge Load Evaluation Report

The Contractor shall submit drawings signed and sealed by a Professional Engineer registered in the Province of Alberta detailing his containment structure, scaffolding, platforms, swing stages, and attachments for the Consultant's review. All scaffolding, platforms, swing stages and material collection equipment shall be designed and operated in accordance with the authority having jurisdiction.

### ~~22.9~~ ~~22.8~~ **22.8 Work Site Health and Safety**

The Contractor is fully responsible for the protection of his employees and any sub-contractor's personnel, from exposure to lead. The Contractor shall develop and implement a Lead Health and Safety Program (LHASP) that meets all the requirements of the Occupational Health and Safety Act and Regulations (Attention is drawn to OH&S Bulletin MSB-06 and in particular the chemical requirements) and all other Municipal, Provincial and Federal Regulations that may apply when working in a hazardous environment.

The Contractor shall provide shower and change facilities for the work force in accordance with governing regulations and ordinances. The facilities shall be freely available for use by all personnel associated with the Contract.

Respirators shall be furnished by the Contractor and used when such equipment is necessary to protect the health of employees. Respirators shall be donned before entering the work area and shall not be removed until the worker has left the work area or has entered a decontamination area. Selection of the respirator type shall be based on the ability of the respirator to adequately filter air which is at the maximum air-lead level monitored in the locations where the worker may be exposed.

Extra protective clothing and clean respirators shall be available for use by visitors to the work site.

The Contractor shall supply employees, who are potentially exposed to lead, with clean, dry, protective work clothing and equipment, and with appropriate changing facilities. Appropriate protective work clothing can include coveralls or similar full body work clothing, gloves, hats, shoes or disposable shoe coverlets, face shields or vented goggles and, if applicable, blasting helmets.

The Contractor shall designate a Health and Safety officer, to act as the primary on site monitor of the program and to ensure that the LHASP is implemented on a daily basis and that all work on the site is in compliance with the LHASP.

### 22.9 Bridge Load Evaluation Report

### ~~22.9~~ ~~Bridge Load Evaluation Report~~

The Contractor shall ~~engage a Professional Engineer registered in the Province of Alberta to prepare and submit a bridge load evaluation report. In the bridge evaluation report the Contractor's Engineer shall identify all loadings imposed on the bridge during the Work or staging of the Work, determine where to transfer the loads to the bridge, and evaluate the ability of the bridge to accommodate the loads~~ in accordance with the Canadian Highway Alberta Transportation Bridge Design Code CAN/CSA-S6 Load Evaluation Manual (BLEM) and the following provisions: this specification.

- ~~Dead loads and dead load factors shall be in accordance with Section 14;~~

~~Vehicle live loads and vehicle live load factors shall be in accordance with Section 14.~~ The load rating evaluation vehicles shall be the Alberta Transportation single unit vehicle (CS -28t), two-unit vehicle (CS2-49t) and vehicle train (CS3-63.5t).

Notwithstanding Clause 14.9.5.3, of the CHBDC, winds loads shall be considered when the Contractor's containment system results in an increased wind loading on the bridge. Wind loads shall be incorporated in the evaluation with load combinations ULS3 and ULS4 as per Section 3. Design wind loads may be adjusted if a written work procedure for removing the screens/containment system at projected wind speeds is developed by the Contractor's Professional Engineer/Contractor, adequately demonstrated, and reviewed and accepted by the Consultant and the Department.

- ~~All other construction live loads and live load factors shall be in accordance with Section 3;~~

Components of the bridge that shall be evaluated and rated include, but are not limited to, the bridge superstructure and bridge bearings. Bridge bearings shall be evaluated and rated in cases where the Contractor's containment system results in an increased wind loading on the bridge in any direction or alternate means of load transfer are imposed on the bridge. Bridge substructure components are typically not included in the evaluation and rating, but may be required at some bridge sites. When required, rating of the bridge substructure will be specified in the Special Provisions of the Contract.

When containment systems include temporary structural elements to strengthen bridge components, details of the fabrication, installation and removal of the temporary structural elements shall be clearly detailed in the bridge load evaluation report.

In addition to the reporting requirements in the BLEM, the bridge load evaluation report shall also provide Live Load RatingCapacity Factors, as described in Clause 14.15, of CSA-S6, for all three load evaluation vehicles under the ultimate limit state ULS1 and shall demonstrate that the bridge capacity is adequate under the ultimate limit states of ULS3 and ULS4. The capacity of the bridge will be considered acceptable if the Live Load RatingCapacity Factors are greater than 1.0 and if the factored resistances exceed the factored load effects.

In addition to the reporting requirements in the BLEM, the bridge load evaluation report ~~shall be stamped by the Contractor's Engineer, and~~ shall clearly identify the magnitude and direction of the imposed loads, where the loads from the containment system will be transferred to the bridge, ~~and the Engineer's and the Contractor's Bridge Load Evaluators and the Bridge Load Evaluation Checkers~~ assessment in the ability of the bridge to accommodate these loads. The report shall be submitted to the Consultant for review and acceptance as part of the Contractor's work proposal.

In case of conflicting requirements between this specification and the BLEM, this specification will govern.

The bridge load evaluation report shall be signed and sealed Professional Engineers (Bridge Load Evaluator and Bridge Load Evaluator Checker) registered in the Province of Alberta.

All costs associated with the preparation of the load evaluation report will be considered incidental to the Work and no separate or additional payment will be made.

#### **22.10** ~~22.10~~ **Protection of Surfaces**

The Contractor shall protect and maintain the painted surfaces until acceptance of the entire project.

The Contractor shall take due precaution against damaging or disfiguring any portion of the bridge with blast media, spatter, spray fog, splashes, smirches of paint or associated painting materials including the fuel and lubricants used with his equipment.

Tarps, polyethylene or other covering material shall be used to protect deck, sidewalks, piers, abutments, slope protection and other portions of the structure adjacent to areas being painted and subject to paint or other damage.

Any inadvertent damage or disfigurement which may occur by reason of the Contractors operations shall immediately be repaired to the satisfaction of the Consultant at the Contractor's expense.

**22.11 ~~22.11~~—Areas Not To Be Painted**

The following surfaces shall not be painted unless noted in the Special Provisions of the Contract:

- Surfaces which will be cast into concrete such as the top and sides of the top flange of girders or the side of expansion joints in contact with concrete~~;~~
- Sliding metal to metal contact bearing surfaces and mating surfaces of spherical bearings~~;~~
- Galvanized surfaces~~;~~ and
- Concrete surfaces adjacent to painted steel surfaces such as sidewalks and the underside of bridge decks. Where painted items such as girder flanges are cast into concrete the paint applied to the flange may overlap the concrete by up to 25 mm on condition that this shall be a uniform straight line as produced by masking the remainder of the concrete surface. Any paint inadvertently applied to the concrete shall be removed immediately.

**22.12 ~~22.12~~—Work Execution****22.12.1 ~~22.12.1~~—Temporary Attachments**

To reduce the possibility of damaging the existing bridge components and painted surfaces, any clamps or other devices attached to the structure shall be padded or designed such that they do not mark or damage the surface to which they are attached.

No welding or tack welding to the structure will be permitted.

The removal and replacement of any bolts from the structure must be acceptable to the Consultant. No holes may be placed in the structure.

**22.12.2 ~~22.12.2~~—Containment System**

The containment system's purpose is to prevent the debris generated during surface preparation from entering into the environment and to facilitate the controlled collection of debris for disposal.

The containment system and its operation shall meet or exceed the class of containment specified in the Special Provisions~~;~~ of the Contract. When abrasive blast cleaning is used to clean and prepare the steel surfaces, the Contractor shall contain the paint chips, abrasive particles, and debris resulting from the operation. The containment system includes but is not limited to, such articles as cover panels, screens, tarps, scaffolds, supports, shrouds and ground sheets used to enclose the entire work area, and equipment to clean, transport, collect, and store blast media~~;~~.

The materials used for screens shall be of a commercial brand designed specifically for the purpose of containing and facilitating collection of blasting and painting debris. If woven screens are used, the material shall contain ~~not~~ more than 15% voids with a mesh opening not exceeding 20 mils (500 microns). If monitoring detects leakage of dust through the woven screens, exceeding the allowable, then the screens shall be replaced with ones of a tighter weave which will meet the recovery requirements. All materials used for screens shall be adequately reinforced to prevent tearing or displacement when subjected to construction, wind or other environmental loads and their related conditions. The Contractor shall supply auxiliary lighting to improve visibility where necessary within enclosures.

### 22.12.3 ~~22.12.3~~ Containment System Monitoring

#### 22.12.3.1 ~~(1)~~ Abrasive Blasting

The containment system shall provide emission control effectiveness such that random escapes to the environment do not exceed 3% of the work day (e.g. 15 minutes over an 8 hour work shift). Operations shall cease immediately if the limits of emission control are exceeded. An enclosure which does not meet the specified criteria shall be modified at the Contractor's expense. Blasting shall not resume until the Contractor has modified his containment system and the modifications have been reviewed and accepted by the Consultant.

The Contractor shall maintain a documented reporting system to provide gross weights, tare of containers and the calculated weight of the material provided to and removed from the structure. The blasting spoil shall be protected from absorbing any moisture. Contaminated blasting spoil shall be in a dry condition prior to making the recovery calculation.

If the wind velocity is too excessive to effectively contain the blast debris within the enclosure, the Contractor shall suspend blast cleaning operations and protect the existing blasting spoil from the wind.

The Contractor shall take whatever measures are necessary to prevent the release of dust or spent material from the ground tarpaulins and other components of the containment enclosure during moving or removal. Debris collected on temporary work platforms, ground cloths, or walls of the containment structure, shall be removed each workday with a vacuum system equipped with high efficiency particulate air (HEPA) filters adequately sized to collect all spent material.

The Contractor shall contain all debris and waste materials as described herein and shall also provide a temporary platform located directly underneath the area enclosed for surface preparation cleaning, power tool cleaning, or blast cleaning and paint application. The platform shall be adequately sized to contain and/or filter debris, wash water and paint during the cleaning or application operation. The containment enclosure shall extend down to the level of the platform and shall be secured to prevent release of other than filtered material. The surface of the platform shall be constructed to ensure collection and filtration of spent waste materials or shall be designed to collect, funnel and discharge the spent waste materials into waste containers.

For bridges located over a navigable waterway the location of platforms, scaffolding, floating booms or other equipment shall not interfere with navigation.

The containment system must be properly maintained while work is in progress and shall not deviate from the approved working drawings without prior acceptance of the Consultant. If, at any time during execution of the work, the containment system fails to function properly, the Contractor shall immediately suspend surface preparation until modifications can be made to correct the deficiency.

Containment meeting these requirements may not necessarily provide adequate emission control or abrasive recovery rate. The Contractor may have to provide a higher containment standard to meet these other requirements.

22.12.3.2 ~~(2)~~—Water Blasting

When High or Ultra High Pressure Water Jetting is specified the filtration or collection and treatment of water used in the cleaning shall be as specified in the Special Provisions of the Contract. The recovery of a certain volume of spoil will not be specified, but the waste water may have to be filtered through a cloth system of specified porosity and when the cleaning is completed the cloth filters shall be carefully folded to contain the debris collected and shall be disposed of as outlined in ~~section 22.16 of this specification~~ Subsection 22.16, Disposal of Blasting Spoil. The Contractor is responsible to perform additional work or to otherwise modify containment or disposal procedures to ensure compliance with all applicable laws and regulations.

22.12.4 ~~22.12.4~~—Ventilation System

The ventilation system used shall be as specified in the Special Provisions of the Contract and described in the SSPC-Guide 6. The use of the minimum ventilation system as described herein does not assure control of emissions to the required level nor will it assure worker safety. Revisions to the ventilating system may be necessary and will be required to meet the health and emission requirements.

The minimum air movement specified in the Special Provisions of the Contract, for inside the Containment system may not be adequate for visibility of the work surface and may or may not be adequate for protection of the workers from health hazards such as lead. The Contractor may have to provide a higher standard of air movement to meet these requirements.

22.12.5 ~~22.12.5~~—Assessing Emissions

Methods for Assessing the Quantity of Emissions shall be as specified in the Special Provisions of the Contract and as described in the SSPC-Guide 6.

The Contractor shall have monitoring equipment to ensure that the containment is performing to the required level.

**22.13 ~~22.13~~ Surface Cleaning**

Prior to the commencement of any surface preparation operations, the Contractor shall carry out surface cleaning on all steel designated to receive a coating system and adjacent surfaces that could contaminate surfaces to be prepared. Surface cleaning shall consist of the hand removal of organic materials such as bird droppings and nests and other non-structural items adhered to the steel, and bridge washing.

Oil, grease and road tar shall be removed manually by solvent cleaning in accordance with SSPC Specification SP1. Remaining area contaminated with residual oil or grease shall be cleaned with an approved biodegradable detergent. The detergent shall be environmentally friendly and non-toxic. The Contractor shall supply copies of the MSDS sheets for the proposed cleaning products to the Consultant for review and acceptance prior to using these materials.

All areas to be coated shall be washed clean of road spatter, chlorides and other contaminants using water of sufficient pressure and volume to flush the contaminants from the structure.

Areas of cleaned steel shall be tested for chloride contaminants, soluble ferrous ions and sulphate contaminants. Chloride contamination shall be tested using Quantab Method or by Kitagawa Tube. Soluble ferrous ion contaminants shall be tested using ferrous ion test strips. Sulphate contaminants shall be tested using a barium chloride optical comparator or an alternative method accepted by the Consultant.

Cleaning shall result in surfaces with less than 7  $\mu\text{g}/\text{cm}^2$  of chloride ion ~~contaminants;contaminant~~, less than 10  $\mu\text{g}/\text{cm}^2$  of soluble ferrous ion ~~contaminants;contaminant~~, and less than 17  $\mu\text{g}/\text{cm}^2$  of sulphate ~~contaminantscontaminant~~. All testing shall be carried out by the Contractor and the results submitted to the Consultant for review and acceptance prior to commencing surface preparation operations.

Wash water shall be captured, filtered and disposed of in compliance with all applicable laws and regulations.

**22.14 ~~22.14~~ Surface Preparation****22.14.1 ~~22.14.1~~ Abrasive Blast Cleaning**

All compressed air sources shall have oil and moisture separators, attached and functional, properly designed and sized to allow delivered air at the blasting or painting nozzle to be free of oil and moisture and of sufficient pressure to accomplish the associated work efficiently and effectively. The tanks on the air compressors and the moisture separators shall, as a minimum, be drained at the end of each working shift. Prior to abrasive blast cleaning, the Contractor shall demonstrate to the Consultant that the air is moisture free. Air driven power tools shall be properly lubricated in accordance with the respective Manufacturer's instructions, but in such a manner that lubrication is not deposited onto the surface being prepared.

Blast cleaning of steel surfaces in preparation for painting, shall be in accordance with the SSPC Surface Preparation Standards specified in the Special Provisions of the Contract.

Surface Preparation Standard SSPC-SP6 requires that the cleaned surface be free of all visible oil, grease, dirt, dust, mill scale, rust and paint.

Surface Preparation Standard SSPC-SP7 requires the removal of all loose coating, loose rust and loose mill scale. Mill scale, rust and paint are considered to be tightly adhered if they cannot be lifted with a dull putty knife.

The anchor pattern in the blasted steel shall be that specified by the manufacturer of the coating.

As work progresses a 150 mm wide strip of uncoated blasted steel shall be left between the newly coated surface and the ~~non-blasted~~nonblasted surfaces of the structure.

The Contractor shall grind all burs and sharp edges to the satisfaction of the Consultant. This requirement shall be measured using an “L” shaped metal gauge with a  $\frac{1}{32}$ ” (1.0 mm) radius at the point of intersection of the two 90° arms. The member will require grinding if the radius touches the member when both arms are in tight contact with the surfaces of the member.

The Contractor shall prepare only as much surface as can be coated with primer the same day. If unusual circumstances occur which prevent all prepared surfaces from being primed the same day, a light blast cleaning will be required over all un-primed surfaces prior to recommencement of painting.

Care shall be exercised to prevent contamination of blast-cleaned or coated surfaces prior to over coating. Compressed air cleaning of the members before coating application will generally be accepted. At the discretion of the Consultant, this operation may be requested in any area before the application of any coat of paint. The degree of surface preparation specified shall exist immediately prior to the coating material being applied. Paint shall be protected from contamination by blasting debris until it has cured sufficiently. Paint contaminated with blasting grit shall be removed and re-applied.

Prepared surfaces shall be kept clean at all times, before coating and between coats.

#### **22.15** ~~22.15~~ **Pack Rust**

Pack rust is the term used for the condition where two areas of steel have been held tightly together by rivets or bolts, and subsequent crevice corrosion has forced these areas apart with a build-up of corrosion products between them. Pack rust that forces plates or structural sections apart to form a gap of 2 mm or greater shall be cleaned to a depth of one half of the gap width, to a maximum depth of ~~6.0~~ mm, treated with an approved penetrant and caulked to form a water tight seal along the top edge and the two sides of plate involved. The bottom edge or lowest edge of the plate or member shall not be caulked.

The type of penetrant and caulking used must be compatible with the paint system used and shall be applied according to the Manufacturer’s instructions. No penetrant or caulking shall be used which has not been accepted by the Consultant. When only one plate edge is exposed, a fillet of caulking shall be applied when the pack rust gap is greater than or equal to 3 mm. The fillet is not required where there is no separation of the plates due to pack rust.



Regardless of whether pack rust is evident or not, all connection plates shall be treated with an approved penetrant and caulked as described. All costs associated with the penetrant treatment and caulking will be considered incidental to the Work and no separate or additional payment will be made.

#### **22.16** ~~22.16~~ **Disposal of Blasting Spoil**

The collection, storage and disposal of blasting residue shall be carried out in compliance with federal, provincial and municipal laws.

All waste residue collected during the surface preparation process shall be stored at the site in containers acceptable to the Consultant. The waste containers shall be stored in an acceptable area and shall be protected at all times with water-proof covers. Waste residues collected and stored in the waste containers will be sampled and tested by the Contractor in accordance with the Toxic Characteristic Leachate Procedure (TCLP) test. The test results will characterize the waste residue as a hazardous or non-hazardous material and the Contractor shall dispose of the blast residue accordingly. The representative test results, for each batch of blasting residue collected shall be provided to both the Consultant and the Department before disposal of waste can be undertaken.

It is the Contractor's responsibility to provide documentation to the Consultant that all hazardous waste was disposed of in conformance with all applicable regulations governing the disposal of such materials. Acceptable documentation shall consist of a certificate of disposal that will provide information such as the quantity of material, truck manifests, way bills, and other information necessary to clearly document the transportation of, and the final disposal method and disposal site used.

#### **22.17** ~~22.17~~ **Priming and Painting**

##### **22.17.1** ~~22.17.1~~ **Stripe Painting**

Stripe painting is a process whereby an additional layer of paint is applied to all sharp edges of the structure being painted to increase the thickness of the coating around the sharp edge. The Contractor shall apply stripe paint along all sharp changes in steel surfaces, including but not limited to, edges of flanges, stiffeners, bracing, plates, bolts, nuts, washers, rivets, plates, and sections with sharp profile. Stripe painting may be applied prior to the prime coat or after the prime coat to aid in preservation of the blast cleaned surface. Drying times and recoat conditions must be compatible with all other coats of the paint system. Paint systems using an intermediate coat shall also be stripe painted after each intermediate coat, but not after the top coat. Stripe coats when applied over the primer or intermediate coat shall be tinted to contrast the underlying coat.

##### **22.17.2** ~~22.17.2~~ **Paint Application**

~~(1)~~ Paint shall be applied in accordance with the Manufacturer's instructions. When required the coating Manufacturer's representative shall be available at the site, to provide guidance and solve problems.

~~(2)~~—The use of thinners will only be permitted when reviewed and accepted by the Consultant and the Department. Thinners will only be considered for use where the Contractor has CQ1 or CQ2 qualifications. Thinners shall be supplied by the manufacturer and formulated for the coat requiring thinning. The thinner shall only be used in accordance with and within the range stated on the manufacturers' published product data sheet. If no range is stated on the manufacturers published product data sheet, the use of thinners will not be permitted.

Paint shall not be applied when the air and/or steel temperatures are at or below 4 °C, nor when the metal has absorbed sufficient heat (above 50 °C) to cause the paint to blister and produce a porous paint film, nor when it is possible the air temperature may drop below 0 °C before the paint is dry. Variances from these requirements, due to paint supplier's recommendations or requirements, require the Consultants acceptance prior to usage.

~~(3)~~—Paint shall not be applied to damp or frosty surfaces, nor applied to surfaces when there is a risk of dew. Painting shall not commence unless the dry bulb temperature exceeds the wet bulb temperature by more than 5 °C and the ambient temperature is rising.

~~(4)~~—Only the anticipated quantity of paint required for one day's work is to be opened on that day. Left over paint shall not be left exposed to air. Any paint that becomes oxidized, thickened, ropy, lumpy or dirty shall be discarded.

~~(5)~~—The paint shall be mixed in a manner which will ensure breaking up of all lumps, complete dispersion of settled pigment, and provide a uniform composition. The paint shall be agitated often enough during application to keep the pigment in suspension.

~~(6)~~—After further evaluation of our qualification testing, and discussions with our committee, we would accept thinning required for application only under the following conditions:

Paint shall not remain in spray pots, painter's buckets, etc., overnight. Multi component paints which have been mixed for the duration of the Manufacturer's recommended pot life shall be discarded in a safe manner.

~~(7)~~—Paint shall be safely stored by the Contractor, in a location which keeps its temperature between 10 °C to 25 °C.

~~(8)~~—Paint shall be applied by spraying, brushing, rolling or a combination of these methods. On all surfaces which are inaccessible for brushes or rollers and where spraying cannot be employed, the paint may be applied with sheepskin mitts specifically manufactured for this purpose.

~~(9)~~—Finish coat paint shall not be applied over wet touched up primer.

~~(10)~~All portions of the paint system shall be within the range of film thickness(es) in which it was originally approved. Bolts, rivets, edges of members and other changes in surface contour shall also receive the required film thickness(es).

~~(11)~~—To ensure that the proper dry film thickness is obtained, the wet film thickness shall be checked at the time the paint is applied. The minimum wet film thickness shall be equal to the dry film thickness divided by the percentage (expressed as a decimal) of solids in the paint used, with the result rounded up to the next full mil. Each painter shall have his own wet film thickness gauge and do frequent checks of the paint film as it is applied. Dry film thickness shall be verified with a Type 2 constant pressure probe magnetic gauge as defined by SSPC-PA 2. The magnetic gauge shall be calibrated in accordance with SSPC-PA 2.

## 22.18 ~~22.18~~—Quality Control

To ensure that the work done meets the requirements of this specification, the Contractor shall have an experienced quality control person solely dedicated to actively monitoring and correcting the work of his employees whenever cleaning, surface preparation and coating application is taking place. The Consultant will provide a NACE certified quality assurance inspector to monitor and accept the Work. The Contractor shall provide him and all other representatives of the Consultant and Alberta Transportation, at their request, safe free access to all areas of the work in all stages of completion.

There shall be no application of coating materials until the cleaning, and surface preparation have been inspected and accepted by the Consultant. Failure to follow this requirement will necessitate the complete removal, by blast cleaning, of all coating placed over surfaces not inspected and accepted by the Consultant. Each coat must be thoroughly dry and the mil thickness of each coat accepted by the Consultant prior to applying an additional coat.

## 22.19 ~~22.19~~—Authority of the Consultant

Non-compliance with any portion of this specification ~~may~~will result in the Consultant suspending the work until the infraction has been corrected. There will be no alteration to the completion date, ~~lane charge dates and site occupancy as applicable~~ due to this suspension of the Work. Lane rental charges and site occupancy will continue to be assessed during periods of work suspension.

## 22.20 ~~22.20~~—Acceptance

Painted surfaces will be rejected, if any of the following defects are identified:

- ~~(1)~~—Runs, sags, holidays or shadowing~~;~~
- ~~(2)~~—Evidence of poor coverage at bolts, plate edges, lap joints, crevices, pockets, corners and re-entrant angles~~;~~
- ~~(3)~~—Surfaces which have been struck, scraped, spotted by rain or otherwise damaged~~;~~
- ~~(4)~~—Surfaces which exhibit an objectionable texture such as orange peel, mud cracking, fish eyes, etc~~;~~ and

- ~~(5)~~ Surfaces ~~damaged by~~with over spray.

#### **22.21 ~~22.21~~ Repair**

Areas requiring repair, shall be cleaned of all damaged paint and the system re-applied using all coats typical to the original paint system. Each coat shall be thoroughly dry before applying subsequent coats. The Contractor shall carry out all repairs to the satisfaction of the Consultant at no additional cost to the Department.

Support points for work platforms or containment structures shall be painted with the accepted paint system. Work platform designs shall consider the potential to adjust touch points so coatings can be applied as work progresses. The Contractor may submit proposed alternate paint systems and application procedures for the painting of touch points, however, any proposed alternate paint systems shall be equivalent in the protection provided, expected durability and the manner in which the system ages so visual uniformity is preserved over the life of the coating. The use of alternate materials and methods will be at the sole discretion of the Department and Consultant.

#### **22.22 ~~22.22~~ Site Clean-Up**

The Contractor shall leave the entire site in a neat and tidy condition with all paint cans, masking materials and other debris removed from the site and disposed of in manner acceptable to the Consultant and the Department.

#### **22.23 ~~22.23~~ 5 Year Bridge Painting Warranty**

The Contractor shall warranty the Work against all defects in material and workmanship for a period of five years. The warranty period will commence on the date of the final acceptance of the Work. The Contractor shall execute the form entitled, "5 Year Bridge Painting Warranty", a sample copy of which is contained in this specification.

During the warranty period, the Consultant and/or the Department will conduct yearly inspections of the coating system. A final inspection of the coating system will be carried out a minimum of sixty days prior to the expiration of the warranty period.

Failure of the coating system shall include, but not be limited to: Any de-bonding or failure of adhesion of the coating either to the structural steel or lack of inter-coat adhesion; the appearance of any rust stains on the structure due to loss of paint or due to leaking from joints between structural members; any loss of normal gloss or rapid change of colour of the coating. Damage to the coating due to vehicle impact or snow removal equipment will not constitute failure of the system.

Repair under warranty shall include, but is not limited to, all permitting, approvals, traffic accommodation, containment systems, labour, materials, equipment, tools and incidentals necessary to restore the coating to a condition acceptable to the Department at no cost to the Department.

Warranty repairs shall be completed within 60 days of notification or, in the event this would place the repair work period in winter weather conditions, by the following June 30.

**5 YEAR BRIDGE PAINTING WARRANTY**

---

(Name of Contractor)

---

(Contract Number)

---

(Bridge File Number and Name)

---

(Name of Paint Manufacturer)

---

(Paint System Name)

The undersigned party agrees to provide a 5 year warranty for the Work. The warranty period ~~will shall~~ commence ~~upon final acceptance by on~~ the ~~Department~~date of the ~~work~~Contract Completion Certificate is issued and shall include all labour, materials, equipment, tools and incidentals necessary to repair all defects and restore the coating to a condition acceptable to the Department, at no cost to the Department.

CONTRACTOR:

|

---

---

\_\_\_\_\_  
(Name of Company Officer)      (Corporate Position)      (Signature of Company Officer)

---

---

\_\_\_\_\_  
(Name of Witness)      (Signature of Witness)      (Date)

## **22.24**    ~~22.24~~ Shop Coating of Structural Steel for Bridges

### 22.24.1    ~~22.24.1~~ Fabrication Paint Shop

Paint shops or areas of fabrication shops where painting is performed shall be well lit, free of dust and drafts and maintained at the correct temperature and relative humidity for the coating being applied.

Compressed air for cleaning and painting shall be free of moisture and oil contamination.

### 22.24.2    ~~22.24.2~~ Pre-Surface Preparation

Surfaces to be coated shall free of weld spatter, welding flux and cutting slag. All sharp corners and edges shall be lightly ground to a 1.0 mm chamfer to break the sharp edge and all holes shall be free of burrs and cutting chips. Oil and grease shall be solvent cleaned to meet the requirements of SSPC SP1 specification for solvent cleaning, prior to blast cleaning in preparation for coating.

### 22.24.3    ~~22.24.3~~ Abrasives

Abrasives used in shop cleaning shall be free of chlorides and other contaminants which could affect the coating being applied, and shall produce the anchor pattern required by the coating system.

---

**22.24.4 ~~22.24.4~~—Blast Cleaning**

Unless noted otherwise noted all fabricated surfaces shall be blast cleaned to meet the requirements of SSPC-SP10 Near White Blast Cleaning, which is a surface free of all visible oil, grease, dust, dirt, mill scale, rust, coating, oxides, corrosion products, and other foreign matter. The surface roughness of the cleaned surface shall be from 5 to 15 µm. No paint shall be applied until the Consultant has inspected and accepted the cleaned surface. Surfaces which have been painted without acceptance of the cleaning shall have the paint removed by blast cleaning and must be accepted by the Consultant before the paint can be applied again.

**22.24.5 ~~22.24.5~~—Masking**

All areas not to be painted shall be masked prior to applying paint. This includes portions of members within 100 mm of field weld locations. Unless noted otherwise, all faying surfaces and within 75 mm of open holes shall be masked to prevent application of coating. All clip angles and other detail material shall be applied after blast cleaning to assure a cleaned faying surface.

**22.24.6 ~~22.24.6~~—Paint**

Unless noted otherwise, shop primer shall be an inorganic zinc rich primer from the Alberta Transportation Product List – Approved Products “Bridge Coating Systems – Paint”.

**22.24.7 ~~22.24.7~~—Paint Application**

Paint shall be applied to the specified Dry Film Thickness (DFT) of 35 to 45 µm (100 -120 µm wet film thickness). Painters shall be equipped with wet film thickness gauges to assure proper application thickness. DFT shall be checked and accepted by the Consultant prior to shipping the work.

**22.24.8 ~~22.24.8~~—Intercoat Cleanliness**

The initial blast cleaned surface and subsequent coats of paint shall be kept free of dust, dry spray, overspray, oil and grease prior to application of subsequent coats or shipping.

**22.24.9 ~~22.24.9~~—Recoat Time**

The maximum and minimum recoat time for the coating system being applied shall be observed and required conditioning agents or surface roughing between coats shall be done.

**22.24.10 ~~22.24.10~~—Shipping Inspection**

No product is to be shipped until the Consultant has inspected and accepted the coating. ~~Section 22.20~~Subsection 22.20, Acceptance, shall apply. Material shipped without inspection by the Consultant, may be inspected at the receiving point with all costs of this inspection charged to the ~~Fabricator~~Contractor.

~~22.24.11 22.24.11—Shipping~~

The coating shall be protected from damage during shipping.

~~22.25—Estimated Areas~~~~22.25 The estimate of painted areas contained Measurement and Payment~~~~22.24.1222.25.1 Protection of the Environment~~

General in the Special Provisions is presented as a convenience to the Contractor bidding the work. The areas shown will be used in pro-rating the value of work completed to date, during the course of the project. While it is believed that the areas are a good representation of the actual painted area of the structure, the Consultant makes no claim as to the accuracy of the values and in no way can be held responsible for the use of these values for any purpose whatsoever.

~~22.25.1.1 22.26—Payment~~

Protection of the environment consists of all required on site protection measures, including but not limited to:

- Measurement and monitoring of background contamination levels;
- Installation, maintenance, and removal of containment measures;
- Containment, treatment and disposal of wash water;
- Removal, containment and disposal of contaminates resulting from abrasive blast cleaning and other surface preparation operations;
- Monitoring and containment of emissions; and
- Site clean-up and restoration;

All costs associated with protection of the environment associated with work carried out in a shop or fabrication facility will be considered incidental to the Work, and no separate or additional payment will be made.

~~22.24.1222.25.1.2 Payment by Unit Price~~~~22.26.1—Surface Preparation and Painting~~

Payment for ~~Surface Preparation and Painting~~protection of the environment will be made ~~on~~at the ~~basis of the lump sum~~unit price bid, ~~which shall include per span for “Protection of the Environment”, and will be~~ full compensation for ~~the cost of furnishing all labour, materials, equipment, tools and incidentals necessary to complete the Work.—~~to the satisfaction of the Consultant.

~~Progress payments will be made on a monthly basis and will be based on the percentage of the total estimated area satisfactorily cleaned, prepared and coated as determined by the Consultant. Payment will not be made for areas which do not have the specified number of coats for the paint system used nor for surfaces that require repair as per Section 22.21.~~



~~22.26.2 — 60% of the unit price bid will be paid once the containment structure has been installed and the Contractor is ready to commence surface preparation and painting. The remaining 40% of the unit price bid will be paid once all surface preparation and painting has been acceptably completed; all blasting spoil has been accounted for; the blasting spoil has been removed from the bridge site and the Contractor has provided the Consultant with written acceptance of the waste materials from the owner of the disposal site; the containment structure and equipment has been removed; and the area is returned to a condition acceptable to the Consultant.~~

### 22.25.1.3 Payment by Lump Sum

#### ~~Protection of the Environment~~

#### ~~22.26.2.1 General~~

Payment for protection of the environment will be made ~~by either unit price per span or at the lump sum price bid as applicable. Payment will not be made for work related to shop coating projects. Payment~~“Protection of the Environment”, and will be full compensation for all labour, materials, equipment, tools and incidentals necessary to complete the Work to the satisfaction of the Consultant.

#### ~~22.26.2.2 Unit Price per Span Price Bid~~

~~When the Unit Price Schedule contains unit price bid for this work, each payment will be made in stages as follows:~~

- ~~— An initial payment of 60% of the unit lump sum price bid will be made paid once the containment structure and equipment for a respective span have has been acceptably installed; and the Contractor is prepared to commence commences surface preparation and painting operations.~~

~~.. The final remaining 40% of the unit lump sum price bid will be paid when the work on the respective span once all surface preparation and painting has been acceptably completed; all blasting spoil has been accounted for; the blasting spoil has been removed from the bridge site and the Contractor has provided the Consultant with written acceptance of the waste materials from the owners owner of the disposal site(s); the containment structure and equipment has been removed; and the area is returned to a condition acceptable to the Consultant.~~

#### ~~22.26.2.3 Lump Sum Price Bid~~

~~When the Unit Price Schedule contains lump sum price bid for this work, payment will be made in stages as follows:~~

- ~~— An initial payment of 60% of the lump sum price bid will be made once the complete containment structure and equipment have been acceptably installed; and the Contractor is prepared to commence surface preparation and painting operations.~~
- ~~— The final 40% of the lump sum price bid will be paid once the work has been acceptably completed; all blasting spoil has been accounted for; the blasting spoil has been~~

~~removed from the bridge site and the Contractor has provided the Consultant with written acceptance of the materials from the owners of the disposal site(s); the containment structures and equipment has been removed; and the area is returned to a condition acceptable to the Consultant.~~

#### 22.25.2 Surface Preparation and Painting

##### 22.25.2.1 Estimated Surface Area

The Contractor is advised that the estimated quantity of surface area to be painted as specified in the Special Provisions of the Contract are approximate, and are provided for bidding and payment pro-rating purposes only.

The estimated quantities are based on as-built drawings, and are considered to be representative of the actual surface areas to be prepared and painted. However, the Department neither implies nor guarantees the complete accuracy of these quantities. The Contractor shall satisfy himself that the estimated quantities are representative of the Work to be carried out prior to submitting a bid; and he shall have no claim against the Department for any inaccuracies of these quantities.

##### 22.25.2.2 Payment

Payment will be made at the lump sum price bid for "Surface Preparation and Painting", and will be full compensation for all operations necessary to clean and prepare the surfaces for the application of coatings; the treatment of pack rust; stripe painting; the supply and application of coating systems; and all labour, equipment, tools and incidentals necessary to complete the Work as shown on the Drawings and to the satisfaction of the Consultant.

Progress payments will be based on the estimated percentage of the total surface area acceptably cleaned, prepared and coated as determined by the Consultant. Areas will not be measured for payment until all coats of the selected coating system have been applied and the areas inspected and accepted by the Consultant.

# STANDARD SPECIFICATIONS FOR BRIDGE CONSTRUCTION

## SECTION 23 STRUCTURAL LUMBER AND PILING

### TABLE OF CONTENTS

<b>23.1</b>	<b>General</b>	<b>23-1</b>
<b>23.2</b>	<b>Standards</b>	<b>23-1</b>
<b>23.3</b>	<b>Material Specification</b>	<b>23-1</b>
23.3.1	Planking (S1S1E Strip Deck)	23-1
23.3.2	Sheeting, Retainers, Nailers and S1S1E Subdeck	23-1
23.3.3	Rough Caps	23-1
23.3.4	Framed Subcaps	23-2
23.3.5	Wheelguards	23-2
23.3.6	Rough Stringers	23-2
23.3.7	Struts and Handrails Posts	23-2
23.3.8	S1S1E Cleats	23-2
23.3.9	Railing	23-2
23.3.10	Piling	23-3
23.3.10.1	Dimensions	23-3
23.3.10.2	Sapwood	23-4
23.3.10.3	Knots	23-4
23.3.10.4	Straightness	23-4
23.3.10.5	Pitch Streaks	23-4
<b>23.4</b>	<b>Air Seasoning</b>	<b>23-4</b>
<b>23.5</b>	<b>Kiln Drying</b>	<b>23-5</b>
<b>23.6</b>	<b>Incising</b>	<b>23-5</b>
<b>23.7</b>	<b>Creosote Treatment</b>	<b>23-5</b>
<b>23.8</b>	<b>Chromate Copper Arsenate (CCA) Treatment</b>	<b>23-5</b>
<b>23.9</b>	<b>Handling, Storage and Care of Wood</b>	<b>23-6</b>
<b>23.10</b>	<b>Inspection</b>	<b>23-6</b>
<b>23.11</b>	<b>Acceptance</b>	<b>23-6</b>



### 23.1 General

This specification is for the supply and treatment of dimensional structural lumber and round timber piles. Dimensions are metric, imperial dimensions are shown in parentheses.

### 23.2 ~~23.2~~ Standards

The grading shall be as per National Lumber Grading Authority (NLGA) ~~-1999~~2014 Standard Grading Rules for Canadian Lumber and CAN/CSA O141-~~94~~05 - Softwood Lumber.

The round wood piles shall be as per CAN3-056-~~M79~~10 (R2015).

The treatment shall conform to CSA-080-~~97~~15 Wood Preservation, CSA-~~080.2-97~~O80.2-15 Processing and treatment; CSA O80.3-15, Preservative Treatment of Lumber, Bridge Ties, and Mine Ties by Pressure Process; CSA-080.3-97 Preservative Treatment of Piles by Pressure Processformulations and American Wood Preservers Association (AWPA) Standard C1, C2, M4 and Supplementary Requirements to M4.

### 23.3 ~~23.3~~ Material Specification

All material shall be full sawn unless otherwise noted in the Special Provisions~~Contract~~.

#### 23.3.1 ~~23.3.1~~ Planking (S1S1E Strip Deck)

The material shall be Species Group HEM-FIR conforming to the stress grade “No. 1 Structural Joists and Planks” (NLGA paragraph 124 b), allowing a maximum of 20% of the Board Measure (BM) to conform to the stress grade “No. 2” of each size length supplied.

#### 23.3.2 ~~23.3.2~~ Sheeting, Retainers, Nailers and S1S1E Subdeck

The material shall be Coast Douglas Fir or Pacific Coast Hemlock species conforming to the stress grade “No. 1 Structural Joists and Planks” (NLGA paragraph 124 b), allowing a maximum of 15% of the Board Measure (BM) to conform to the stress grade “No. 2 Structural Joists and Planks”, (NLGA paragraph 124 c).

#### 23.3.3 ~~23.3.3~~ Rough Caps

The material shall be Coast Douglas Fir species, conforming to the stress grade “Select Structural Posts and Timbers” (NLGA paragraph 131 a).

#### 23.3.4 Framed Subcaps

The material shall be Coast Douglas Fir species, conforming to the stress grade "Select Structural Posts and Timbers" (NLGA paragraph 131 ~~a~~). The 305 mm x 355 mm (12" x 14") cap has a length of 4.6 m (15'). From the center of the 4.6 m (15') length in both directions along the length, for the 355 mm (14") depth, the cap is cut on a continuous 2% slope which results in an end depth of 310 mm (12¼"). The 305 mm (12") width remains constant.

#### ~~23.3.4 Framed Subcaps~~

~~The material shall be Coast Douglas Fir species, conforming to the stress grade "Select Structural Posts and Timbers" (NLGA paragraph 131 a). The 305 mm x 355 mm (12" x 14") cap has a length of 4.6 m (15'). From the center of the 4.6 m (15') length in both directions along the length, for the 355 mm (14") depth, the cap is cut on a continuous 2% slope which results in an end depth of 310 mm (12¼"). The 305 mm (12") width remains constant.~~

#### 23.3.5 ~~23.3.5~~ Wheelguards

The material shall be Coast Douglas Fir or Pacific Coast Hemlock species conforming to the stress grade "No. 1 Structural Beams and Stringers" (NLGA paragraph 130 b), allowing a maximum of 15% of the BM to conform to the stress grade "No. 2 Structural Beams and Stringers" (NLGA paragraph 130 c).

#### 23.3.6 ~~23.3.6~~ Rough Stringers

The material shall be Coast Douglas Fir species conforming to the stress grade "Select Structural Beams and Stringers" (NLGA paragraph 130 a), allowing a maximum of 10% of the BM to conform to the stress grade "No. 1 Structural Beams and Stringers" (NLGA paragraph 130 b).

#### 23.3.7 ~~23.3.7~~ Struts and Handrails Posts

The material shall be Coast Douglas Fir or Pacific Coast Hemlock species, conforming to the stress grade "Select Structural Post and Timbers" (NLGA paragraph 131 a) allowing a maximum of 15% of the BM conforming to the stress grade "No. 1 Structural Post and Timbers" (NLGA paragraph 131 b).

#### 23.3.8 ~~23.3.8~~ S1S1E Cleats

The material shall be Coast Douglas Fir or Pacific Coast Hemlock species, conforming to the stress grade "No. 2 Structural Joists and Planks" (NLGA paragraph 124 c).

#### 23.3.9 ~~23.3.9~~ Railing

The material shall be S4S and is to be of the Coast Douglas Fir or Pacific Coast Hemlock species conforming to the stress grade "No. 1 Structural Joists and Planks" (NLGA paragraph 124 b).

23.3.10 ~~23.3.10~~ Piling

All piles shall be cut from sound trees of Douglas Fir or Pine. The piles shall be clean peeled soon after being felled. All bark shall be thoroughly removed and no pile shall be considered thoroughly peeled unless all the rough bark and all the inner bark have been removed. When a portion of pile is rough and convoluted, the inner bark may remain in the depressions, provided that any such depression is not more than 20 mm ( $\frac{3}{4}$ " ) in width and 205 mm (8" ) in length.

23.3.10.1 ~~(a)~~ Dimensions

Unless otherwise specified, the minimum diameter after the outer and inner bark has been removed and after seasoning, ~~will be as follows:~~ shall in accordance with Table 23-1, Sizes of Timber Piles and Table 23-2, Minimum Circumference.

**Table 23-1: Sizes of Timber Piles**

Length (m)		Tip Diameter <del>(mm)</del>		Butt Diameter <del>(mm)</del>	
(m)	(feet)	(mm)	(inches)	(mm)	(inches)
Up to 6.1 (20')	<u>20</u>	230 <del>(9")</del>	<u>9</u>	305 <del>(12")</del>	<u>12</u>
6.2 to 12.2 ( <del>20.25' to 40'</del> )	<u>20, 25 to 40</u>	205 <del>(8")</del>	<u>8</u>	305 <del>(12")</del>	<u>12</u>
12.3 to 18.3 ( <del>40.25' to 60'</del> )	<u>40, 25 to 60</u>	180 <del>(7")</del>	<u>7</u>	330 <del>(13")</del>	<u>13</u>

However, a pile may be 12 mm ( $\frac{1}{2}$ " ) smaller in either or both tip and butt diameters in one axis provided that the minimum circumferences are as follows:

**Diameter~~————~~Table 23-2: Minimum Circumference**

<del>(mm)</del>	<del>————</del>	<del>(mm)</del>
180 (7")	————	535 (21")
205 (8")	————	610 (24")
230 (9")	————	685 (27")
305 (12")	————	940 (37")
330 (13")	————	1015 (40")

<u>Diameter <sup>(1)</sup></u>		<u>Circumference</u>	
<u>(mm)</u>	<u>(inches)</u>	<u>(mm)</u>	<u>(inches)</u>
<u>180</u>	<u>7</u>	<u>535</u>	<u>21</u>
<u>205</u>	<u>8</u>	<u>610</u>	<u>24</u>
<u>230</u>	<u>9</u>	<u>685</u>	<u>27</u>
<u>305</u>	<u>12</u>	<u>940</u>	<u>37</u>
<u>330</u>	<u>13</u>	<u>1015</u>	<u>40</u>

Notes:

(1) The maximum butt diameter shall not exceed 405 mm (16").

23.3.10.2 ~~(b)~~—Sapwood

The minimum thickness of the sapwood shall be 12 mm ( $\frac{1}{2}$ " ) as measured on the small end of the pile. However, no pile will be rejected where the thickness of the sapwood falls below 12 mm ( $\frac{1}{2}$ " ), but not lower than 10 mm ( $\frac{3}{8}$ " ) for a distance of 150 mm (6") as measured around the circumference, provided it is of the minimum thickness around the balance of the circumference.

23.3.10.3 ~~(c)~~—Knots

Single knots will not be considered a defect unless they are loose or show signs of decay. A "knot cluster" that is the grouping of two or more knots together as a unit, with the fibres of the wood deflected around the entire unit, shall be reason for rejection of the pile. All knots shall be trimmed close to the body of the pile.

23.3.10.4 ~~(d)~~—Straightness

A line drawn from the centre of the butt and to the centre of the tip shall lie within the body of the pile. Piles shall be free from short bends in which the distance from the centre of the pile to a line stretched from the centre of the pile above the bend to the centre of the pile below the bend exceeds 4 ~~per cent~~% of the length of the bend, or 65 mm ( $2\frac{1}{2}$ " ).

23.3.10.5 ~~(e)~~—Pitch Streaks

Pitch streaks that extend through the length of the pile shall be cause for rejection.

**23.4 ~~23.4~~—Air Seasoning**

Air seasoning shall be as per Clause 1.7 of CSA 080.M1-97 (Guide for Purchasers and Specifiers of Treated Wood). Moisture content shall not be more than 19% prior to treatment.



**23.5 ~~23.5~~—Kiln Drying**

The material may be kiln dried in lieu of air seasoning as per Clause 1.10 of CSA 080.M1-97 (Guide for Purchasers and Specifiers of Treated Wood). The moisture content shall not exceed 19% prior to treatment. The supplier shall ensure that the material is stacked to allow maximum ventilation between lumber and reduce any warping or checking.

**23.6 ~~23.6~~—Incising**

The material shall be incised on all four sides and all around for round piles prior to treatment by a method that will provide at least the minimum penetration specified without any damage and with the least loss of strength.

**23.7 ~~23.7~~—Creosote Treatment**

~~(1) The material~~ Material shall be seasoned and incised as per ~~Clauses 4.0 or 5.0~~ Subsection 23.4, Air Seasoning, Subsection 23.5, Kiln Drying, and 6.0 shall be Subsection 23.6, Incising, and pressure treated using 100 % creosote treatment.

Creosote treatment shall conform to CSA-080.2-97 - Preservative Treatment of Lumber, Bridge Ties, and Mine Ties by Pressure Process and AWP Standard C1 and C2. The retention shall be 96 kg/m<sup>3</sup> (6 lb/ft<sup>3</sup>) by gauge, 128 kg/m<sup>3</sup> (8 lb/ft<sup>3</sup>) by assay.

**23.8 Chromate Copper Arsenate (CCA) Treatment ~~(2)~~**

Material shall be seasoned and incised as per Subsection 23.4, Air Seasoning, Subsection 23.5, Kiln Drying, and Subsection 23.6, Incising, and pressure treated using a waterborne preservative Chromate Copper Arsenate (CCA).

CCA treatment shall conform to CSA-080.2-97 - Preservative Treatment of Lumber, Bridge Ties, and Mine Ties by Pressure Process and AWP Standard C1 and C2. The retention shall be 96 kg/m<sup>3</sup> (6 lb/ft<sup>3</sup>) by gauge, 128 kg/m<sup>3</sup> (8 lb/ft<sup>3</sup>) by assay.

**~~23.8 Chromate Copper Arsenate (CCA) Treatment~~**

~~(1) When noted in the Special Provisions the planking material (strip deck) and guardrail posts seasoned and incised as per Clauses 4.0 or 5.0 and 6.0 shall be pressure treated using a waterborne preservative Chromate Copper Arsenate (CCA).~~

~~(2) Treatment shall conform to CSA-080.2-97 - Preservative Treatment of Lumber, Bridge Ties, and Mine Ties by Pressure Process and AWP Standard C1 and C2.~~

~~(3) The retention and penetration shall be 6.4 kg/m<sup>3</sup> (0.4 lb/ft<sup>3</sup>) and 10 mm (0.4”), respectively by assay.~~

~~23.8~~23.9 ~~23.9~~—Handling, Storage and Care of Wood

Wood shall be kept free of dirt and shall be stored in a location which will not create an excessive increase in temperature (~~green house~~greenhouse effect) resulting in rapid drying of the material. Wood shall be stored in a manner, which will prevent ponding or trapping of excess moisture between surfaces where it cannot dry readily.

Where oil treatment is used, the wood shall be given three coats of creosote oil to repair all cuts, abrasions and holes made after the pressure preservative treatment. Each coat shall be allowed to dry before the next coat is applied.

Repair of cuts, abrasions and holes in material treated with water-borne preservative shall conform to CSA 080 and AWPB.

~~23.9~~23.10 ~~23.10~~—Inspection

The supplier shall provide for inspection of the material by an independent inspector who is qualified and has a minimum of 10 years of experience for this type of inspection. All material shall be inspected prior to and after the treatment. All material shall be stamped by the inspector identifying the inspection date and that the material meets or exceeds the required specifications. The stamp shall be placed at the end of each member in a location that is clearly visible even when the material is in a large stockpile. A written report from the inspector along with his experience and qualifications indicating the material meets the specifications with a "Certificate of Compliance" shall be forwarded to the Consultant ~~and Owner~~.

~~23.10~~23.11 ~~23.11~~—Acceptance

~~(1)~~—All materials shall be subject to inspection ~~by~~ review and acceptance of the Consultant/~~Owner~~ prior to usage.

~~(2)~~—Where S1S1E or S4S Size is specified the material shall be not more than 6 mm (1/4") scant per side.

~~(3)~~—When for example 15% "No. 1" or 15% "No. 2" grade is allowed, this shall mean 85% must be the specified grade and not more than 5% of the 15% is below "No. 1" or "No. 2" grade or there will be grounds for ~~reinspection~~ re-inspection.

STANDARD SPECIFICATIONS FOR BRIDGE CONSTRUCTION

SECTION 24 **OVERHEAD** SIGN STRUCTURES AND PANELS

TABLE OF CONTENTS

<b>24.1</b>	<b>General</b>	<b>24-1</b>
<b>24.2</b>	<b>Overhead Sign Structures</b>	<b>24-1</b>
24.2.1	Design	24-1
24.2.1.1	Design Standards	24-1
24.2.1.2	Foundations	24-2
24.2.2	Supply and Fabrication	24-4
24.2.2.1	Standards	24-4
24.2.2.2	Qualification	24-5
24.2.2.2.1	Certification	24-5
24.2.2.2.2	Quality Management System	24-5
24.2.2.3	Engineering Data	24-5
24.2.2.3.1	Welding Procedures	24-5
24.2.2.3.2	Overhead Sign Structure Design Notes, Independent Check Notes, and Shop Drawing Submission Requirements	24-6
24.2.2.3.3	Proposed Fabrication Sequence	24-7
24.2.2.3.4	Mill Test Reports and Product Data Sheets	24-7
24.2.2.3.5	Schedules	24-8
24.2.2.3.6	Material Traceability	24-8
24.2.2.4	Materials	24-8
24.2.2.4.1	Steel	24-8
24.2.2.4.2	Bolts	24-9
24.2.2.4.3	Anchor Rods	24-9
24.2.2.5	Welding	24-9
24.2.2.5.1	Filler Metals	24-10
24.2.2.5.2	Cleaning Prior to Welding	24-10
24.2.2.5.3	Longitudinal Seams	24-10
24.2.2.5.4	Weld Penetration	24-10
24.2.2.5.5	Preheat and Interpass Temperatures	24-11
24.2.2.5.6	Tack and Temporary Welds	24-11
24.2.2.5.7	Run off Tabs	24-11
24.2.2.5.8	Methods of Weldment Repair	24-11
24.2.2.5.9	Arc Strikes	24-11
24.2.2.5.10	Plug and Slot Welds	24-12
24.2.2.6	Fabrication	24-12
24.2.2.6.1	Pre-fabrication Meeting	24-12
24.2.2.6.2	Cutting of Plate	24-12
24.2.2.6.3	Material Splices	24-13
24.2.2.6.4	Fabrication Detail Requirements	24-13
24.2.2.6.5	Dimensional Tolerances	24-14
24.2.2.6.5.1	Straightness	24-14
24.2.2.6.5.2	Twisting	24-14
24.2.2.6.5.3	Length	24-14

	24.2.2.6.5.4	Across the Flat Dimensions .....	24-14
	24.2.2.6.5.5	Flatness Tolerance of Column Base Plates and Flange Plates.....	24-15
	24.2.2.6.5.6	Arm Rise .....	24-15
	24.2.2.6.6	Pre Assembly .....	24-16
	24.2.2.6.7	Galvanizing.....	24-16
	24.2.2.6.8	Base Plate Corrosion Protection.....	24-16
	24.2.2.7	Testing and Inspection.....	24-17
	24.2.2.7.1	General .....	24-17
	24.2.2.7.2	Welds .....	24-17
	24.2.2.7.3	Witness Points.....	24-18
	24.2.2.8	Identification Tag .....	24-20
	24.2.2.9	Notification to Ship.....	24-20
	24.2.2.10	Fabrication Outside of Canada .....	24-20
<b>24.2.3</b>		<b>Foundation Construction .....</b>	<b>24-21</b>
	24.2.3.1	General.....	24-21
	24.2.3.2	Anchor Rod Installation.....	24-21
<b>24.2.4</b>		<b>Erection.....</b>	<b>24-21</b>
	24.2.4.1	General.....	24-21
	24.2.4.2	Grout Pads .....	24-22
	24.2.4.2.1	Grouting in Cold Weather .....	24-23
	24.2.4.3	High Tensile Strength Bolted Connections.....	24-24
	24.2.4.3.1	Bolt Tension .....	24-24
	24.2.4.4	Anchor Rod Nut Tightening.....	24-26
<b>24.3</b>		<b>Sign Panels .....</b>	<b>24-26</b>
	24.3.1	Sign Panel and Connection Design Notes, Independent Checker Notes and Shop Drawing Submission Requirements .....	24-27
	24.3.2	Materials .....	24-28
	24.3.2.1	Sheeting Materials .....	24-28
	24.3.2.2	Backing.....	24-28
	24.3.2.3	Extruded Aluminum Preparation .....	24-28
	24.3.2.4	Application of Sheeting Materials.....	24-29
	24.3.3	Construction.....	24-29
<b>24.4</b>		<b>Clean Up.....</b>	<b>24-30</b>
<b>24.5</b>		<b>Measurement and Payment .....</b>	<b>24-30</b>
	24.5.1	Overhead Sign Structures .....	24-30
	24.5.2	Sign Panels.....	24-31

**24.1 General**

This specification is for the design, supply, fabrication, erection and all associated work pertaining to bridge support or cantilever type overhead ~~and cantilevered~~ sign structures and sign panels.

The underground utilities located on the Drawings are approximate and are to be confirmed by the Contractor in the field.

~~Prior to design and construction, the Contractor shall confirm underground and overhead utility conflicts with the sign bases and support structure and immediately inform the Consultant of these conflicts. Any costs associated with addressing these underground utility conflicts shall be included in the bid price of the foundation.~~

**24.2 ~~24.2~~ Overhead Sign Structures****24.2.1 ~~24.2.1~~ Design****24.2.1.1 ~~24.2.1.1~~ Design Standards**

The design of overhead sign structures and panels shall be ~~carried out~~completed by the Contractor, using the general layout information prepared by the Consultant. ~~The Contractor's design engineer shall be a Professional Engineer registered to practice in the Province of Alberta under the APEGGA Act contained on the Drawings and in accordance with these specifications.~~

The design of overhead sign structures and panels shall be in accordance with the requirements of AASHTO Standard Specifications for Structural Supports for Highway Signs, Luminaires and Traffic Signals, ~~latest Edition and Interims,~~ (AASHTO Standard Specifications), unless noted otherwise in these specifications. The design equation 3-1 referenced in Clause 3.8.1, of AASHTO Standard Specifications shall be modified as follows:

~~AASHTO equation 3-1, Clause 3.8.1,  $P_z = 2.5qK_zC_d$ , where; q shall be modified as follows:~~

$$P_z = 2.5 q K_z C_d$$

~~where q shall be taken~~determined from ~~CAN/CSA S6-06~~, Table A3.1.1 for a return period of 50 years.

The design ice thickness for ice accretion shall be the value given in ~~CAN/CSA S6-06~~ Figure A3.1.4.

~~For the design of all cantilevered sign structures, the~~ The Fatigue Importance Factors in AASHTO Standard Specifications Table 11-~~6~~-1 shall be based on Fatigue Category I. ~~for the design of all cantilever type overhead sign structures.~~

Further to ~~AASHTO Standard Specifications section~~Subsection 11.7 “~~Fatigue Design Loads~~”of the AASHTO Standard Specifications, a dynamic analysis of the structure will not be accepted in lieu of using the equivalent static pressures provided in the specifications.

Further to Subsection 11.7.1.1, Galloping, of the AASHTO Standard Specifications~~section 11.7.1 “Galloping”~~, the Department will not ~~approve~~accept the use of vibration mitigation devices in lieu of designing to resist periodic galloping forces. Furthermore, the Department requires that the galloping loads be part of the fatigue design of all ~~overhead~~ cantilevered type overhead sign ~~support~~ structures regardless of their configuration.

Further to Subsection 11.8, Deflection, of the AASHTO Standard Specifications~~section 11.8 “Deflection”~~, the vertical deflection for overhead sign structures shall not exceed 200 mm regardless of their configuration.

Design sign panel area shall be taken as the largest of:

- ~~(a)~~ — Actual sign panels shown on the drawings.
- ~~(b)~~ — Future sign panels shown on the drawings; and
- ~~(c)~~ — Area of 3.5 m x 60% of horizontal span length (span length includes portion of arm over clear zone), placed in any position along the span that will produce the most critical loading conditions in the structure.

Overhead sign structures shall have a minimum permanent vertical camber of L/200 under a loaded condition, where L is the span of the horizontal arm of the sign structure.

Cantilever arm lengths shall not exceed ~~20m~~20 m.

The top of the concrete foundations shall project from 700 mm to 850 mm above the adjacent ground surface on the traffic side. The exposed portion of the concrete foundation shall be of circular cross -section.

The minimum vertical “as constructed” clearance measured to the bottom edge of sign panel of overhead sign structures shall be 6.0 ~~metres~~m. The bottom edge of the structural framing for the sign shall be at least 0.6 m higher than the bottom edge of the sign panels.

#### ~~24.2.1.2—Design Notes and Drawings~~

~~All design notes and shop drawings, shall be stamped, signed, and sealed by the Contractor's design engineer.~~

#### ~~24.2.1.2 Two copies of the design notes and five copies Foundations~~

The Contractor shall undertake a geotechnical investigation to facilitate foundation design of the overhead sign structure. All costs associated with the geotechnical investigation will be considered incidental to the Work and no separate or additional payment will be made.

~~Any proposed adjustments to the locations of the shop drawings overhead sign structures foundations shall be submitted to the Consultant and the Department for review and acceptance at least three weeks in advance of scheduled fabrication prior to commencement of the Work.~~

~~The Contractor shall incorporate as-built conditions and re-submit all design notes and shop drawings, at the completion of construction.~~

~~(1) — Design Notes~~

~~Design notes shall be presented in a legible and logical format and shall be sufficiently detailed to allow a technical review of the design concepts and assumptions used in the design. The design notes shall include, as a minimum, calculations for the following:~~

~~(a) Design moment, shear and axial force envelopes for serviceability and fatigue criteria.~~

~~(b) Columns~~

~~(c) Horizontal arm or truss~~

~~(d) Column or arm flange bolted connections~~

~~(e) — Concrete shall be Class C, utilize Type HS or HSb hydraulic cement, and be in accordance with Section 4, Cast-In-Place Concrete.~~

~~All welded connections, stiffeners, etc.~~

~~(f) Anchor rods~~

~~(g) Foundation~~

~~(2) — Shop Drawings~~

~~The shop drawings reinforcing steel shall be legible plain reinforcing steel and of adequate quality to be reproduced and microfilmed. All drawings shall be done on standard 11 x 17 or 22 x 34 sheet sizes in accordance with Section 5, Reinforcing Steel.~~

~~The shop drawings shall include the following:~~

~~(a) Alberta Transportation Bridge File numbers, A-Ident numbers and project title, as provided by the Consultant, Grout pads shall be shown on all the shop drawings.~~

~~(b) Design criteria meeting the requirements of section 24.2.1.1, for each individual sign structure, including:~~

- ~~• AASHTO Standard Specifications for Structural Supports for Highway Signs, Luminaires and Traffic Signals latest Edition and Interims~~
- ~~• Initial sign panel area and/or minimum design sign panel area~~
- ~~• Design wind pressure~~
- ~~• Fatigue category and fatigue loadings~~
- ~~• Design ice utilized under column base plates and shall be between 50 mm and 75 mm total thickness~~
- ~~• Other dead loads~~

- ~~• Design temperature range~~
- ~~• Foundation soils parameters~~
- ~~• Critical anchor rod forces~~

~~(c) Each individual shop fabricated section or assembly shall be shown separately with complete and clearly identified welded or bolted details.~~

~~(d) Weld procedure identification. Grout pad recesses shall be shown on 25 mm in depth below the shop drawings in the tailtop of the weld symbols concrete surface.~~

~~(e) All material splice locations shall be shown on the drawings.~~

~~(f) Complete material list.~~

~~(g) Erection procedure including any temporary supports, grouting and tightening procedure for anchor rod nuts.~~

#### ~~24.2.1.3 Consultant Review~~

~~The design notes and drawings will be reviewed by the Consultant solely to ascertain conformance with codes and specifications. Responsibility of the final design remains solely with the Contractor. The Consultant's acceptance of the shop drawings shall not be construed as relieving the Contractor from his responsibility for errors or omissions in the calculations and drawings or for proper completion of the work in accordance with the contract.~~

~~After the Consultant review, the Contractor shall revise the drawings and calculations as required to the satisfaction of the Consultant without any additional cost to the Department.~~

~~Prior to commencing fabrication, all shop drawings shall be clearly signed by the Department's Consultant as verification that the Consultant has completed his review and accepted the Shop Drawings. The Consultant's review and acceptance of the Shop Drawings will apply to general arrangements and details of design but not to figured dimensions or details of fabrication, and will be subject to the requirements of specifications and to such corrections as may be marked here on.~~

#### ~~24.2.2 Supply and Fabrication~~

##### ~~24.2.2.1 Standards~~

##### ~~24.2.2 Fabrication~~

##### ~~24.2.2.1 Standards~~

~~Fabrication of overhead sign structures shall conform to AASHTO LRFD Bridge Construction Specifications and the American Welding Society (AWS) - Bridge Welding Code D1.5.~~

~~Where imperial/metric conversions are necessary, The National Standard of Canada, CAN3-Z234.1-79 shall be used as the basis of conversion.~~

All welding, cutting and preparation shall be in accordance with the American Welding Society (AWS) - Bridge Welding Code D1.5 and D1.1.



~~24.2.1.2~~ ~~24.2.2.2~~ 24.2.2.2 — Qualification

~~24.2.1.2.1~~ ~~24.2.2.2.1~~ (1) — Certification

~~The Overhead sign structures and panels shall be supplied and fabricated by a fabricator shall operate a recognized steel fabricating shop accepted by the Consultant.~~

~~The Fabricator shall be fully approved certified by the Canadian Welding Bureau (CWB) as perin accordance with CSA Standard W47.1 in Divisionsto Division 1 or 2.~~

The Contractor shall notify the Consultant and the Department ~~and Consultant~~ of any subcontractorsfabricators in his employ. The Contractor shall remain responsible for the Work of ~~the subcontractors.fabricators.~~ All terms of the Contract, ~~such as CWB approval and right of access~~ shall apply to the subcontractorfabricators.

~~Only~~ Welders, welding operators and tackers shall be CWB approved by the Canadian Welding Bureau in the particularapplicable category ~~shall be permitted to perform weldments.~~ Their qualifications shall be current and available for examination by the Consultant upon request.

~~24.2.1.2.2~~ ~~24.2.2.2.2~~ (2) — Contractor's Quality Management System

~~The Contractor shall maintain acceptableA quality management system throughout the contract. The purpose of the quality management system is to ensure that the product meets the quality requirements of the contract and is delivered on time. The Contractor's quality management system shall apply to all stages of theincludes design, material procurement, manufacturing, testing, transportation and delivery of the productshall be maintained.~~

~~24.2.1.3~~ ~~24.2.2.3~~ 24.2.2.3 — Engineering Data

~~24.2.1.3.1~~ ~~24.2.2.3.1~~ (1) — Welding Procedures

Welding procedures including welding procedure datasheets shall be submitted for each type of proposed weld used in the structure. ~~The.~~ Weld procedures shall bear the approval of the Canadian Welding Bureau and shall also be reviewedapproved by the CWB and submitted to the Consultant and the Department and Consultant for review and acceptance a minimum of 3 weeks prior to ~~use on commencement of the structure~~Work.

24.2.2.3.2 (2) — Overhead Sign Structure Design Notes, Independent Check Notes, and Shop Drawing Submission Requirements

Design notes, independent check notes, and shop drawings shall be signed and sealed by the design engineer of record and by an independent checker. The design engineer of record and the independent checker shall be Professional Engineers registered in the Province of Alberta. Design notes, independent check notes and shop drawings shall be submitted to the Consultant for review and acceptance a minimum of 3 weeks in advance of the commencement of fabrication. Review comments provided by the Consultant and/or the Department shall be incorporated into the design notes, independent check notes and shop drawings and resubmitted to the Consultant for review and acceptance prior to the commencement of fabrication.

The design engineer of record and independent checker shall submit separate signed and sealed design notes and independent check notes. The design and independent check notes shall be presented in a legible and logical format, clearly identify material properties, and sufficiently detailed to allow a technical review of design concepts and assumptions used. All material properties shall be confirmed and documented by the design engineer of record and independent checker prior to the commencement to fabrication. As a minimum, design notes and independent check notes shall include analysis and design calculations of the following:

- Moment, shear and axial force envelopes for serviceability and fatigue criteria;
- Columns;
- Horizontal arm or truss;
- Column or arm flange bolted connections;
- All welded connections, stiffeners, etc.;
- Anchor rods; and
- Foundations.

The independent checker may be employed by the same company as the design engineer of record. The independent check must be completed fully independent of the design engineer of record, including a complete re-analysis of all aspects of the design including calculations and engineering, preferably by a methodology or computer program other than that used by the design engineer of record. The design engineer of record and independent checker shall ensure that the shop drawings are complete and accurately convey the design criteria and assumptions used in their designs.

Shop drawings shall be electronic unlocked PDF format. Each shop drawing shall include the Department's shop drawing identification block and have a sufficient blank space for the Consultant's review stamp. The Department's shop drawing identification block will be provided to the Contractor upon request. As a minimum, the following information shall be included on shop drawing submissions:

- Bridge file and structure number(s), A Ident numbers, and project name;
- Design criteria meeting the requirements of Subsection 24.2.1.1, Design Standards, for each individual overhead sign structure, including:

- AASHTO Standard Specifications for Structural Supports for Highway Signs, Luminaires and Traffic Signals latest Edition and Interims;
- Initial sign panel area and/or minimum design sign panel area;
- Design wind pressure;
- Fatigue category and fatigue loadings;
- Design ice thickness;
- Other dead loads;
- Vertical camber in loaded and unloaded conditions;
- Design temperature range;
- Foundation soils parameters; and
- Critical anchor rod forces.
- Each individual shop fabricated section or assembly shall be shown separately with complete and clearly identified welded or bolted details;
- Number, spacing and locations of the aluminum T sections required for each sign panel(s);
- Weld procedure identification shall be shown on the shop drawings in the tail of the weld symbols;
- All material splice locations shall be shown on the drawings;
- Location and details of identification marks;
- Complete material list;
- Erection procedure including any temporary supports, tightening procedure for anchor rod nuts and grouting of base plates; and
- Assembly and mounting details of panel.

The design notes, independent check notes, and shop drawings will be reviewed by the Consultant solely to ascertain general conformance with codes and specifications. The Consultant's review and acceptance shall not be considered as relieving the Contractor of the responsibility for completing the Work in accordance with the Contract requirements.

The Contractor shall incorporate as-built construction conditions into design notes, independent check notes, and shop drawings. One paper copy and one electronic copy (PDF format) of as-built design notes, independent check notes, and shop drawings shall be submitted to the Consultant within 3 weeks of construction completion.

#### 24.2.1.3-24.2.2.3.3 Proposed Fabrication Sequence

Prior to commencement of fabrication, the Contractor shall present for review and acceptance an outline of the fabrication sequence and equipment being used that clearly describes the order of make-up and assembly of all the component parts, as well as shop assembly, and inspection stations.

#### (3) — Mill Certificates

#### 24.2.2.3.4 ~~Mill certificates~~ Mill Test Reports and Product Data Sheets

Mill test reports and product data sheets shall be provided for all ~~material before~~ materials in English.

Mill test reports and product data sheets shall be submitted to the Consultant for review and acceptance 3 weeks prior to the commencement of fabrication commences.

Where mill test ~~certificates~~reports originate from a mill outside Canada or the United States of America, the Contractor shall have ~~the material tested and the~~ mill test ~~certificate~~reports verified by a ~~Canadian certified~~ laboratory. ~~This in Canada by testing the material to the specified material standards, including boron content. The testing~~ laboratory shall be certified to ISO/IEC 17025 by an organization accredited by the Standards Council of Canada ~~to comply with the requirements of ISO/IEC 17025 for the specific tests or type of~~ for the tests required by the material standard specified on the mill test certificate. The mill test certificates shall be stamped with the name of the Canadian. Samples for testing shall be collected by personnel employed by the certified laboratory and the signature of an authorized officer. It shall state. A verification letter shall be provided by the certified laboratory that the material is in conformance with the specified ~~includes at a minimum, the applicable mill test reports, testing standards, date of verification testing, and declaration of material compliance with~~ Contract requirements. The verification letter shall be signed by an authorized officer of the certified laboratory.

~~24.2.1.3.3~~24.2.2.3.5 (4) — Schedules

The Contractor shall provide and keep current a complete fabrication schedule in a form satisfactory to the Consultant.

24.2.2.3.6 ~~24.2.2.4~~ Material Traceability

A list of all material, including hardware, shall be provided for each structure showing the component designation from the shop drawings and the associated mill test report heat numbers. The structure number shall be noted on the hardware mill test reports.

~~24.2.1.4~~24.2.2.4 — Materials

(a) — All materials shall be new.

(b) — The use of aluminum and aluminum alloy ~~are~~will not ~~acceptable, unless specifically stated otherwise by the Consultant~~be permitted.

(c) — Steel materials including hardware and anchor rod assemblies shall be hot dip galvanized.

24.2.2.4.1 Steel

Structural steel plate material shall conform to either CSA G40.21M Grade 300W\* or 350W\* or ASTM A572 ~~GR-Grade~~ 50\*. ~~However,~~

The yield strength of the steel plate shall be limited to 300 MPa when designing for fatigue strength regardless of the material used.

\*Silicon Steel with a boron content exceeding 0.0008% will not be permitted.

The silicon content shall be less than 0.04% for the shafts, whereas for flanges, tenons, and base plates the silicon content shall be either less than 0.04% or 0.15 to 0.25% inclusive.

All other structural shapes except HSS incorporated in the design shall conform to CSA G40.20M21M Grade 300W or 350W with silicon content less than 0.04%.

~~(d) — Steel shafts, structural flange plates, base plates and any material welded to the structure shall meet a Charpy V-Notch minimum average absorbed energy of 20 Joules (J) at -20 °C. Charpy V-Notch testing shall be in accordance with CSA G40.20M on a per plate frequency.~~

~~Hollow structure steel (HSS) members shall conform to CSA G40.20M21M Grade 350W Class H with silicon content less than 0.04%; however, the yield strength of the HSS shall be limited to 300 MPa when designing for strength regardless of the material used. The steel for HSS members shall meet a Charpy V-Notch minimum average absorbed energy of 20 J at -20 °C. Charpy V-Notch testing shall be in accordance with CSA G40.20M on a per plate frequency.~~

#### 24.2.2.4.2 (e) Bolts

~~All bolts shall conform to American Society for Testing and Materials (ASTM) Standard A325 or shall meet property class 8.8 of the Industrial Fasteners Institute for metric high strength structural bolts. The nuts shall be F3125 Grade A325/A325M Type 1 heavy hex style. Nuts shall be heavy hex style and shall conform to ASTM A563 and harden/A563M. Hardened washers shall conform to ASTM F436. Metric bolts shall be marked with the symbol A325M and those of "weathering" steel shall have the A325M symbol underlined. Weathering steel nuts shall be marked with three circumferential lines or shall be marked with a symbol "3". Weathering steel washers shall be identified by a symbol "3". Certified mill test reports for the fastener material shall be provided /F436M. Rotational capacity testing is mandatory and shall be performed in accordance with ASTM F3125.~~

#### 24.2.2.4.3 (f) — Anchor Rods

Anchor rods shall be manufactured from smooth rods conforming to the requirements of ASTM F1554 Grade 55 (Fy=380 MPa) including supplementary requirement S4. The anchor rod assembly shall consist of, but not limited to: anchor rods complete with nuts and washers, top temporary templates c/w clamping nuts, bottom anchor plates c/w anchor nuts and clamping nuts.

~~(g) All steel materials including all hardware and anchor rod assemblies shall be hot-dip galvanized~~

~~24.2.1.5~~ 24.2.2.5 ~~24.2.2.5~~ — Welding~~24.2.1.5.1~~ 24.2.2.5.1 ~~(1)~~ — Filler Metals

Low hydrogen filler, fluxes and low hydrogen welding practices shall be used throughout. ~~Filler metal with AWS designation of hydrogen level of H4 will only be permitted. All electrodes and fluxes used in the Shielded Metal Arc Welding (SMAW) and Metal Core Arc Welding (MCAW) processes shall conform to the diffusible hydrogen requirements of AWS D1.5 filler metal hydrogen designator H4. All electrodes and fluxes used in the Submerged Arc Welding process (SAW) shall conform to the diffusible hydrogen requirements of AWS D1.5 filler metal hydrogen designator H8 or lower.~~ The low hydrogen covering and flux shall be protected and stored as specified by AWS Standard D1.5. Flux cored welding or use of cored filler wires in the submerged arc process or shielding gas processes are not considered as conforming to low hydrogen practice. These methods will not be permitted. ~~However metal core welding process utilizing low hydrogen electrodes will be allowed.~~ The deposited weld metal shall provide strength, durability, impact toughness and corrosion resistance equivalent to the base metal.

Field application of metal core arc welding is not allowed.

~~24.2.1.5.2~~ 24.2.2.5.2 ~~(2)~~ — Cleaning Prior to Welding

Weld areas must be clean, free of mill scale, dirt, grease, and other contaminants prior to welding.

~~(3) — For multi-pass welds, previously deposited weld metal shall also be thoroughly cleaned prior to depositing subsequent passes.~~

~~24.2.1.5.3~~ 24.2.2.5.3 — Longitudinal Seams

All longitudinal seams shall be made by an approved semi or fully automatic submerged arc or metal core welding ~~processes~~ process.

~~24.2.1.5.4~~ 24.2.2.5.4 ~~(4)~~ — Weld Penetration

The column to base plate and flange to horizontal arm full penetration welds shall be completed using backing bars. All other full penetration welds shall be made by using backing bars or backgouged to sound metal. The longitudinal seams shall have a minimum 60% penetration. Backing bars will not be allowed for longitudinal seam welds.

The following welds shall have 100% penetration:

- ~~(a)~~ — Column to base plate;
- ~~(b)~~ — Horizontal arm to flange plate;
- ~~(c)~~ — Longitudinal seam welds within 150 mm of circumferential welds and 150 mm beyond hand holes (when provided) shall be full penetration groove welds. Transition between full and partial penetration welds shall be ground smooth;

- ~~(d)~~ — Backing bar splices. Backing bars for splices shall ~~behave the~~ minimum dimensions of 8 mm x 30 mm for full penetration welds. ~~These shall and~~ be ~~properly~~acceptably fitted and welded all around top and bottom of the member. The groove weld shall be placed in a minimum of two passes. A reinforcing fillet weld shall be placed all around the joint. ~~;~~ and
- ~~(5)~~ — Flange plate to gusset plate.

24.2.1.5.5 ~~24.2.2.5.5~~ Preheat and Interpass Temperatures

Preheat and interpass temperatures shall be as per AWS D1.5. All full penetration welds shall be ~~preheated~~preheated and interpass temperature maintained to a minimum of 100 °C unless a higher ~~temperature~~temperature is required by AWS D1.5 Table 12.3 for the material thickness. The preheat temperature shall be measured 75 mm from the point of welding.

24.2.1.5.6 ~~24.2.2.5.6~~ (6) — Tack and Temporary Welds

Tack and temporary welds shall not be allowed unless they are to be incorporated in the final weld. Tack welds, where allowed, shall be of a minimum length of four times the nominal size of the weld, and shall be subject to the same quality requirements as the final welds. Cracked tack welds shall be completely removed prior to re-welding.

24.2.1.5.7 ~~24.2.2.5.7~~ (7) — Run-off Tabs

Run-off tabs shall be used at the ends of all welds that terminate at the edge of a member. The thickness and shape of the tabs shall replicate the joint detail being welded and shall be a minimum of 100 mm long unless greater length is required for satisfactory work. They shall be tack welded only to that portion of the material that will not remain a part of the structure, or where the tack will be welded over and fused into the final joint. After welding, the tabs are to be removed by flame cutting, not by breaking off.

24.2.1.5.8 ~~24.2.2.5.8~~ (8) — Methods of Weldment Repair

Repair procedures for damaged base metal and unsatisfactory weldments shall be prepared by a welding engineer registered as a Professional Engineer in the Province of Alberta. Repair procedures shall be submitted to the Consultant and the Department for review and acceptance ~~by the Department and Consultant~~ prior to commencement of the repair ~~work commencing~~.

24.2.1.5.9 ~~24.2.2.5.9~~ (9) — Arc Strikes

Arc strikes will not be permitted. ~~In the event of~~

~~If accidental arc strikes, the Contractor shall submit to the Department and occur, a repair procedure shall be prepared by a welding engineer registered as a Professional Engineer in the Province of Alberta. The repair procedure shall be submitted to the Consultant and the Department for review and acceptance a proposed prior to commencement of the repair procedure. At a minimum, the repair procedure shall include the complete grinding out of the crater produced by the arc strike. These areas will be examined by the Consultant to ensure complete removal of the metal in the affected area prior to repair and magnetic particle inspection, and hardness testing of the repaired area. Hardness of the repaired area shall meet the requirements of Subsection 6.2.8.11, Hardness Tests.~~

~~24.2.1.5.10~~ 24.2.2.5.10 (10) — Plug and Slot Welds

Plug welds or slot welds ~~shall~~will not be permitted.

~~24.2.2.6~~ — Fabrication

24.2.2.6 Fabrication

Fabrication, including all repairs, shall be performed in a fully enclosed area which is adequately heated. The shop temperature shall be at least 10 °C. Field welding will not be ~~allowed~~permitted.

~~24.2.1.5.11~~ 24.2.2.6.1 (1) — Pre-~~job~~fabrication Meeting

A pre-fabrication meeting is required ~~prior to commencement of~~ for the supply and fabrication of overhead sign structures and panels. The pre-fabrication meeting ~~will~~shall be held at ~~fabricator's plant~~the fabrication facility and the Contractor shall ensure that the plant~~fabrication~~ superintendent and plant, fabrication manager ~~responsible for the work and any manufacturer's representatives, and supervisors~~ directly involved in the specialized Work are in attendance. ~~The Department/Consultant will conduct this~~ The meeting ~~after the~~shall not occur until shop drawings, design notes and independent check notes, and welding procedures have been reviewed and accepted by the Consultant. ~~The Contractor shall provide two weeks notice to the Department/date of the pre-fabrication meeting shall be reviewed and accepted by the~~ Consultant prior to the meeting.

~~(and the Department and proposed a minimum of 2)~~ weeks prior to the anticipated date.

~~24.2.1.5.12~~ 24.2.2.6.2 Cutting of Plate

All plate material for main members and any plate material welded to the main member shall be flame cut using an automatic cutting machine. Shearing is not allowed.

Corners of plates and structural sections shall be ground to a 1 mm chamfer.



24.2.1.5.13 ~~24.2.2.6.3 (3)~~ — Material Splices

~~Additional splices, other than those shown on the shop drawings, will require acceptance of the Department and Consultant. The Contractor shall bear the cost of inspection of these splices.~~

~~(4) — Additional Requirements~~

~~(a) — If modification to the splice locations shown on the shop drawings are proposed, the Contractor shall submit design notes, check notes, and shop drawings signed and sealed by his design engineer of record and by an independent checker in accordance with Subsection 24.2.2.3.2, Overhead Sign Structure Design Notes, Independent Check Notes, and Shop Drawing Submission Requirements.~~

~~24.2.2.6.4 Fabrication Detail Requirements~~

~~Fabrication detail requirements shall be as follows:~~

- Each column, arm, extension, clamp and bracket shall be fabricated from one or two piece(s) of sheet steel ~~with~~. Each piece of sheet steel shall be the full length of the section being fabricated. A maximum of one longitudinal seam weld shall be used when the section is fabricated from a single piece of sheet steel. A maximum of two longitudinal seam welds ~~unless accepted otherwise shall be used when the section is fabricated from two pieces of sheet steel.~~ Laminating of plates ~~shall~~will not be ~~allowed~~permitted;
- ~~(b) — Intermediate circumferential butt welds will not be allowed however~~ Horizontal members greater than 12 m ~~span~~ may have a bolted splice. Intermediate circumferential butt welds will not be permitted;
- ~~(c) —~~ Columns, arms, extensions and clamps shall be brake press formed or roll formed. The brake press knife shall have a radius suitable for the thickness of the material and nature of the bend. The minimum bend radius for all cold formed sections shall be ~~400mm~~100 mm;
- ~~(d) —~~ All plates and structural sections shall be free of notches and gouges~~;~~;
- ~~(e) —~~ The depth or projection of any imperfections on the inner or outer surfaces shall not exceed 15% of wall thickness. Any depth or projection up to 33% of wall thickness may be repaired by welding. Any excessive projecting weld metal shall be removed~~;~~;
- ~~(f) —~~ The diameter of bolt holes in base plates shall be sized in accordance with ~~CAN/CSA S6-06~~ Clause 10.18.4.2(a). ~~Further,~~ The nominal diameter of all other bolt holes shall be ~~2mm~~2 mm greater than the nominal bolt size~~;~~;
- ~~(g) —~~ Punching of full size holes will not be permitted. The holes shall be circular and perpendicular to the member and shall be deburred to ensure a proper faying surface~~;~~;

- (h) — Hand holes with cover plates on top and bottom of columns are to be provided for illuminated overhead sign structures or when ~~required as per special provisions specified in the Special Provisions of the Contract;~~
- (i) — Hand ~~hole (holes, when required) specified,~~ shall be stiffened by providing a reinforcing rim with semi-circular ends. The rim shall be welded to the member with a full penetration groove weld supplemented with an all-around fillet weld-;
- (j) — Only low stress stamps shall be used for identification marks. ~~The stamps; and specific location shall be shown on the shop drawings and accepted by the Consultant.~~
- (k) — Stiffeners ~~are will~~ not ~~allowed on~~ be permitted for column to base plate and horizontal arm to flange plate connections.

24.2.1.5.14 24.2.2.6.5 (5) — Dimensional Tolerances

~~All fabrication shall meet the~~ Dimensional tolerances ~~described below;~~ shall be measured and recorded by the fabricator.

24.2.1.5.14 24.2.2.6.5.1 (a) — Straightness

The straightness ~~of any item~~ tolerance shall not exceed the overall length divided by 300 from the surface at any point. This shall be measured with a straight line ~~joining the surface at both ends. The difference between the straight line~~ and the surface shall then be measured to determine the straightness.

24.2.1.5.14 24.2.2.6.5.2 (b) — Twisting

The twist in the overall length of any column, arm, or extension shall not exceed 7° degrees.

24.2.1.5.14 24.2.2.6.5.3 (c) — Length

The specified length of any item shall be within 0 to 60 mm or 0 to + 5% (whichever is less) with the exception of sign bridge spans which shall be within 5 mm of the specified dimensions in an unloaded condition. The tolerance for height shall be -0 to +60 mm.

24.2.1.5.14 24.2.2.6.5.4 (d) — Across the Flat Dimensions

Regular Polygonal Cross-sections: The average of all across the ~~flats~~ flat dimensions from a given cross section shall be within 1% of the specified dimension. In addition, the ratio of the maximum to minimum across the ~~flats~~ flat dimensions shall be less than or equal to 1.05.

Irregular Polygonal Cross-sections: The across the ~~flats~~ flat dimensions of the minor and major axis shall be within 2% of the specified dimensions and the sum of the minor and major axis across the ~~flats~~ flat dimensions must be within 1% of the specified dimensions.

~~24.2.1.5.14.5~~ ~~24.2.2.6.5.5~~ (e) — Flatness Tolerance ~~for Flatness~~ of Column Base Plates and Flange Plates

Surfaces of column base plates shall be flat to within 3 mm tolerance in 305 mm, and to within 5 mm tolerance overall. Faying surfaces of flange plates shall be flat to within 2 mm tolerance overall for each surface.

~~24.2.1.5.14.6~~ ~~24.2.2.6.5.6~~ (f) — Arm Rise

~~Arm-rises apply to unloaded structure in the standing position.~~

~~(6) — The minimum armrise (vertical camber) shall within a tolerance of  $\pm 15$  mm from the theoretical design value for the unloaded condition.~~

24.2.1.5.15 ~~24.2.2.6.6~~ Pre-Assembly

After welding and fabrication, but prior to galvanizing, the Contractor shall pre-assemble all overhead sign structures ~~complete with, including~~ welded sign clamps, to check the fit and geometry. The pre-assembled overhead sign structures shall will be inspected, reviewed and accepted by the Consultant.

~~Following inspection by the Consultant, the Overhead sign~~ structures shall be disassembled ~~for after the Consultant review and acceptance prior to~~ galvanizing.

24.2.1.5.16 ~~24.2.2.6.7 (7)~~ Galvanizing

The fabricator shall provide a smooth finish on all edges and surfaces, and remove all weld spatters, and all welding flux residue from the steel components prior to galvanizing.

Factors contributing to galvanization-induced cracking shall be minimized. Galvanizing shall be by the hot dip method, after fabrication, in accordance with the current edition of ASTM A123/A123M Standard Specification for Zinc (Hot-Dip Galvanized) Coatings on Iron and Steel Products and ASTM F2329 Standard Specification for Zinc Coating Hot-Dip Requirements for Application to Carbon and Alloy Steel Bolts, Screws, Washers, Nuts, and Special Threaded Fasteners ~~with additions and exceptions as described in this specification. The Fabricator shall provide a smooth finish on all edges and surfaces, and remove all weld spatter and all welding flux residue from the steel components prior to galvanizing. Lumps, globules or heavy deposits of zinc will not be permitted. All threaded holes or threaded couplings shall be retapped after galvanizing and as modified in this specification.~~

Repair of galvanizing shall only be done if bare areas are infrequent, small, and suitable for repair. A detailed repair procedure shall be submitted to the Consultant and accepted the Department for review and acceptance 3 days prior to its use. ~~It should be noted that repairs may require complete removal commencement of the galvanized coating and re-galvanizing. Repair repair work. Repairs shall be in compliance with meet the requirements of~~ ASTM A780, Method A3 “Metallizing”. ~~However repair~~ For areas not exceeding 100 mm<sup>2</sup>, repairs may be ~~done~~ carried out in accordance with ASTM A780, Method A1 “Repair Using Zinc-Based Alloy”. The thickness of the coating ~~for both methods, regardless of repair method~~, shall be 180 µm, and the repair tested for adhesion. The finished appearance shall be similar to the adjacent galvanizing. The Consultant will determine the acceptability of repaired areas.

~~(8) Galvanized material shall be stacked or bundled and stored to prevent wet storage stain as per the American Hot Dip Galvanizers Association (AHDGA) publication “Wet Storage Stain”. Any evidence of wet storage stain shall be removed to the satisfaction of the Consultant.~~

24.2.1.5.17 ~~24.2.2.6.8~~ Base Plate Corrosion Protection

The bottom facesurface of each base plate shall be protected by a medium grey colour barrier coating accepted by the Consultant, to prevent contact between the zinc and the grout. concrete. The galvanized surface must be roughened prior to application of barrier coating. The surface preparation of the galvanized surface and the dry film thickness (DFT) of the coating shall be in accordance with the coating manufacturer's Manufacturer's recommendations.

The Consultant will test the adhesion of fully cured coating as per ASTM D3359 “Standard Test Methods for Measuring Adhesion by Tape Test.” The method selected for testing (Method A or B) shall depend on the dry film thickness of the coating. The coating ~~manufacturer’s~~ manufacturer’s product data sheets shall be provided to the Consultant prior to the application of the coating. The adhesion test result shall meet a minimum of “4B” classification (i.e. a maximum allowable flaking of 5% ~~).~~ %.

#### 24.2.2.7 ~~24.2.2.7~~—Testing and Inspection

##### 24.2.2.7.1 General

The Contractor’s testing and inspection records shall be open for examination by the Consultant upon request.

##### (1)—Access

All costs associated with testing and inspection requirements shall be the responsibility of the Contractor.

The Contractor shall ~~provide ensure~~ full ~~facilities for the inspection of material and workmanship.~~ Free access shall be allowed to the Consultant to Work all parts of the works times to the Consultant or his testing agencies. When required by the Consultant, the Contractor shall provide ~~needed~~ required manpower for assistance in checking layout and performing inspection duties. Non-destructive testing and other inspection may also be performed by the Consultant or his designated testing agencies.

##### (2)—Testing, inspection and related costs incurred by the Contractor

~~The Consultant resulting from defective work or Contractor shall provide quality control throughout the course of fabrication. All test records made by the fabricating shop in the course of normal quality control shall be open to proposed connections and/or splices not specified on the Consultant for inspection. Testing and inspection made necessary by the repair of faulty work Drawings shall be paid for by the Contractor.~~

The Contractor shall be responsible for all costs incurred by the Consultant to attend the pre-fabrication meeting and inspect the Work being fabricated outside the Province of Alberta. The cost shall also include for a Department’s representative to attend the pre-fabrication meeting and one additional trip during the course of fabrication.

##### 24.2.2.7.2 Welds

The Contractor shall visually inspect all welds.

The Contractor shall test and inspect all full penetration welds ~~inspected either~~ by ultrasonic ~~testing~~ or radiographic ~~inspection~~ methods.

~~The Contractor shall test and inspect~~ partial penetration seam welds ~~shall be inspected~~ by ultrasonic ~~testing method~~. The frequency of partial penetration ~~weld inspections~~ welds shall be three random locations per weld ~~and~~. The length of ~~weld for~~ ultrasonic inspection at each location shall be 200 mm ~~at each weld~~.

~~The Contractor shall arrange to have 25% of all fillet welds inspected by magnetic particle testing.~~

~~Non-destructive testing (NDT) shall be completed by a technician employed by a company certified to CSA W178.1. Magnetic particle inspection, ultrasonic and radiographic testing technicians shall be certified to Level II of CGSB. Ultrasonic testing procedures shall be prepared by a CGSB Level III U/T inspector and signed and sealed by a Professional Engineer.~~

~~Non-destructive testing shall be in accordance with the following standards:~~

- ~~• Radiography - AWS Standard D1.5~~
- ~~• Ultrasonic - AWS Standard D1.5~~
- ~~• Magnetic Particle - ASTM Standard E-709~~

~~Calibration blocks shall be prepared for each thickness shall be prepared of material and used for ultrasonic testing methods to establish sensitivity levels and acceptance criteria. The NDT shall be done by a company certified to CAN/CSA W178.1. Ultrasonic and radiographic testing technicians shall be certified to Level II of CGSB. Ultrasonic testing procedure shall be submitted to the Consultant for review and acceptance prior to commencement of fabrication. Proposed acceptance criteria shall be reviewed and accepted by the Consultant.~~

~~A copy of test testing and inspection results shall be provided to the Consultant indicating within 5 days of completion. Testing and inspection results for partial penetration welds shall also include the percentage of weld penetration.~~

~~The Contractor shall not proceed to the next stage commence with subsequent stages of fabrication until all the submitted testing and inspection seam welds have passed the Quality Control and the weld results have been reviewed and accepted by the Consultant.~~

~~All costs associated with non-destructive inspection of partial and full penetration welds, preparation of calibration blocks, establishing sensitivity levels and acceptance criteria shall be the responsibility of the Contractor.~~

~~The Contractor shall be responsible for all travel, boarding and lodging costs for a Department's representative to attend the prejob meeting and two additional trips during the course of fabrication when the sign structures are being fabricated outside the Province of Alberta.~~

~~(3) Testing by the Consultant~~

~~The Consultant will perform visual inspection. Any additional NDT; such as radiographic, ultrasonic, magnetic particle and any other inspection that may be specified or required will be performed by the Consultant or by his testing agencies at the Consultant's expense.~~

~~(4) Inspection Station~~

~~To insure that each stage of inspection is performed in an orderly manner, during the fabrication, Inspection Stations will be set up at specific points. Certain items of the work will then be checked, and deficiencies shall be corrected, prior to the work being sent to the next stage of fabrication. These check points are to be agreed to by the Department and Consultant and the Fabricator prior to commencement of fabrication. The Department and Consultant reserve the right to stop detrimental fabrication between check points if deemed necessary.~~

~~(5) Non-destructive Methods of Examination~~

~~The methods of non-destructive examination shall be in accordance with the following standards:~~

- ~~-Radiography - AWS Standard D1.5~~
- ~~-Ultrasonic - AWS Standard D1.5~~
- ~~-Magnetic Particle - ASTM Standard E-709~~

~~(6) Inspection Schedule~~

~~All welds will be visually inspected.~~

~~Ultrasonic or radiographic inspection will be performed on full penetration welds.~~

~~24.2.2.7.3 24.2.2.8 Witness Points~~

~~The Contractor shall obtain the Consultant's review and acceptance at the following stages of fabrication prior to commencing with subsequent stages of fabrication:~~

- ~~• Material identification and traceability;~~
- ~~• Fitting and complete joint penetration weld testing of backing bar;~~
- ~~• Completion of all welding prior to shop assembly;~~
- ~~• NDT completed;~~
- ~~• Pre-assembly;~~
- ~~• Galvanizing and base plate corrosion protection; and~~
- ~~• Acceptance prior to shipment.~~

24.2.1.6 24.2.2.8 Identification Tag

The Contractor shall supply and install an identification tag on one column of each overhead sign structure located at 2.4 m above the base plate. The column shall be drilled and tapped for 2 - 10 mm diameter attachment bolts. The identification tag shall be fabricated as per the in accordance with Section 13, Miscellaneous Iron, and Standard Drawing S-1682-1848, Standard Identification Tags.

24.2.2.9 Notification to Ship

The Contractor shall notify the Consultant 72 hours prior to shipment to facilitate inspection and acceptance of the overhead sign structures. Overhead sign structures shall not be shipped until they have been reviewed and accepted by the Consultant. Review and acceptance of overhead sign structures at the fabrication facility by the Consultant will not relieve the Contractor of his full responsibility to meet the requirements of these specifications.

Overhead sign structures that have not been inspected at the fabrication facility will not be paid for until such material has been inspected, reviewed and accepted by the Consultant. The Contractor shall be responsible for all costs incurred by the Consultant for inspection of the overhead sign structures not inspected at the fabrication facility.

24.2.2.10 Fabrication Outside of Canada

All testing and inspection requirements specified in Subsection 24.2.2.7, Testing and Inspection, shall be completed at the fabrication facility and all costs incurred by the Consultant and their designated testing agencies, and the Department shall be paid for by the Contractor.

All components fabricated outside of Canada shall be shipped to CSA W47.1, Division 1 or 2 certified shop in Canada for re-inspection and testing. The components shall be in a condition that facilitates all re-inspection and testing requirements. The re-inspection and testing at the Canadian shop shall be completed in accordance with Subsection 24.2.2.7, Testing and Inspection. The Contractor shall also arrange for inspection by a CSA 178.2 Level III certified welding inspector accredited with W47.1/W59 to inspect all components to ensure that they were not damaged during transportation.

Components shall not be shipped from the Canadian shop until all requirements have been met and the Work has been reviewed and accepted by the Consultant.

The Contractor shall be responsible for all re-inspection and testing costs, including all cost incurred by the Consultant and the Department.

The Contractor shall have no claim against the Department resulting from delays caused by these requirements.



24.2.3 Foundation Construction

24.2.3.1 General

The foundations of overhead sign structures shall be completed in accordance with Section 3, Foundation Piles, Section 4, Cast-In-Place Concrete, and Section 5, Reinforcing Steel.

The Contractor shall coordinate placement of the street light cable and conduit around the sign support foundation.

24.2.3.2 Anchor Rod Installation

Anchor rods shall be installed true and plumb in one complete assembly. The assembly shall be accurately positioned and secured to prevent movement or displacement during concreting procedures. 24.2.3—Welding of components will not be permitted.

24.2.4 Erection

24.2.4.1 General

The Contractor shall maintain the stability, safety and integrity of the overhead sign structure until grout pads have achieved the specified strength and anchor rod nuts are fully tightened.

The Contractor shall provide traffic accommodation until grouting and anchor rod nut tightening has been completed. Temporary traffic accommodation strategy requirements for overhead sign structure erection shall be submitted to the Consultant for review and acceptance a minimum of 1 week prior to commencement of the Work.

### Erection

Any product damaged in shipping or during erection shall be replaced at no ~~extra~~ cost to the Department.

The Contractor shall not erect the ~~structural steel~~ overhead sign structure until the ~~substructure~~ foundation concrete has been cured a minimum of three days and achieved 80% of the 28 day specified concrete strength requirement.

All components shall be handled with care to prevent stress to the components through bending or twisting. The use of steel chains as slings shall not be permitted. Any damage to the components through overstress, scratching or denting shall be repaired or replaced at the Contractor's expense and to the satisfaction of the Consultant.

~~The Contractor shall be responsible for any additional supports to maintain stability until the anchor rod nuts are fully tightened.~~

After the top temporary template for the anchor rod assembly and clamping nuts are completely removed, the overhead sign structure shall be set accurately on galvanized shims on top of the concrete foundation. ~~The~~ Shim plates must ~~shall~~ be located ~~so~~ such that a minimum of 75 mm of ~~distance~~ grout cover is provided from shims to the grout edge.

The method of forming and placing grout pads shall be acceptable to the Consultant and in accordance with Subsection 24.2.4.2, Grout Pads.

Hand hole bolts shall be coated with anti-seize lubricant.

#### 24.2.4.2 Grout Pads

Grout shall be selected from the Alberta Transportation Product List, Non-Shrink Grout category.

The grout pad recess shall be 25 mm deep and the total grout thickness shall be as shown on the Drawings. The top of finished grout pads shall not be higher than the underside of the column base plate.

The method of forming and pouring the grout shall be submitted to the Consultant for review and acceptance. ~~Base plates shall be grouted with Sika 212 flowable grout or equivalent. Dry-pack methods of constructing grout pads will not be accepted. The top of the finished grout elevation shall not be higher than the underside of the column base plate.~~

Grout shall be packaged in waterproof containers with the production date and shelf life of the material shown. It shall be mixed and placed in strict accordance with the manufacturer's recommendations stated on their published product data sheet.

The Contractor shall utilize experienced ACI or CSA certified testers to test the compressive strength of the grout in accordance with CSA A23.2-1B. A set of compressive strength cubes shall be taken to represent each days production or 0.25 m<sup>3</sup>, whichever is more frequent. All test results shall be provided to the Consultant. The average minimum compressive strength of 3 cubes at 28 days shall be 30 MPa. Failure to meet the minimum specified compressive strength will result in the grout pad being removed and replaced at the Contractor's expense.

Grout shall be wet cured for a minimum of 3 days with two layers of clean, saturated Nilex 4504 white coloured filter fabric or an approved equivalent. Water used for wet curing shall be clean and acceptable to the Consultant.

Sealer shall be applied to the exposed grout pad surfaces in accordance with Subsection 4.26, Type 1c Sealer.

#### 24.2.4.2.1 Grouting in Cold Weather

When the air temperature is, or is expected to be below 5 °C as forecasted by the closest Environment Canada Meteorological Station during the placing and curing period, or when determined by the Consultant, a cold weather grouting plan shall be implemented. The Contractor shall submit details of his proposed cold weather grouting plan to the Consultant for review and acceptance a minimum of 2 weeks prior to any grout placement. The following minimum requirements for grouting in cold weather shall be included in the cold weather grouting plan:

- Before placing grout, pre heat shall be provided to raise the temperature of formwork, anchor rods, base plate, and substrate surfaces to between 10 °C and 20 °C;
- Mixing water shall be heated to a temperature of at least 20 °C but not more than 65 °C;
- Temperature of the grout during placing shall be between 10 °C and 25 °C;
- Grout shall be wet cured a minimum of 72 hours;
- The Contractor shall enclose the structure in such a way that the grout and air within the enclosure can be kept at or above 15 °C for a protection period of 5 days after placing the grout. Enclosures shall be constructed with a minimum 300 mm clearance between the enclosure concrete and/or grout surfaces; and
- Protection and heating, when used, shall be withdrawn in such a manner so as not to induce thermal shock stresses in the grout. The temperature of the grout shall be gradually reduced at a rate not exceeding 10 °C per day to that of the surrounding air. To achieve this, in an enclosure, the heat shall be slowly reduced.

The Contractor shall demonstrate to the satisfaction of the Consultant that the requirements of the cold weather concreting plan are met.

~~Hand hole bolts shall be coated with anti-seize lubricant.~~

~~24.2.1.7~~ 24.2.4.3 ~~(1)~~ — High Tensile Strength Bolted Connections

Bolted parts shall fit solidly together when assembled. Contact surfaces shall be free of dirt, grease, burrs, pits and other defects that would prevent solid seating of the parts. Connections shall be assembled with a hardened washer under the bolt head or nut, whichever is the element turned in tightening. Surfaces of bolted parts in contact with the bolt head and nut shall be parallel.

~~24.2.1.7.1~~ 24.2.4.3.1 ~~(2)~~ — Bolt Tension

~~Each bolt shall be tightened so as to provide, when all bolts in the joint are tight, at least the minimum bolt tension shown in the following table for the size of bolt used:~~

**Table 1 — Bolt Tension**

Specified Bolt Size (A325M Bolts)	Minimum Bolt Tension		Commonly Supplied Equivalent Imperial Size (A325 Bolts)	Minimum Bolt Tension	
	Kilonewtons	pounds-force		Kilonewtons	pounds-force
M16X2	94	21,180	5/8	85	19,200
M20X2.5	147	33,050	3/4	126	28,400
M22X2.5	181	40,700	7/8	175	39,250
M24X3	212	47,660	1	227	51,500
--	--	--	1-1/8	251	56,450
M30X3.5	337	75,760	1-1/4	319	71,700
--	--	--	1-3/8	380	85,450
M36X4	490	110,160	1-1/2	463	104,000

~~All structural bolts shall be tightened by using turn of nut method to provide bolt tension specified in Table 1. There shall first be enough bolts brought to a "snug tight" condition to ensure that the parts of the joint are brought into full contact with each other. Snug tight is defined as the tightness attained by a few impacts of an impact wrench or the full effort of a man using an ordinary spud wrench. Following this initial operation, bolts shall be placed in any remaining holes in the connection and brought to snug tightness. All bolts in the joint shall then be tightened additionally by the applicable amount of nut rotation specified below, with tightening progressing systematically from the most rigid part of the joint to its free edges. During this operation there shall be no rotation of the part not turned by the wrench.~~

~~Amount of rotation of nut relative to bolt, regardless of which is turned:~~

- ~~—1/3 turn where bolt length is 4 bolt diameters or less~~
- ~~—1/2 turn where bolt length is over 4 bolt diameters and not exceeding 8 bolt diameters~~
- ~~—2/3 turn where bolt length exceeds 8 bolt diameters~~

Notes

- ~~—tolerance 1/6 turn (60°) over, nothing under~~
- ~~—length of bolt measured from underside of head~~

~~24.2.4 Foundation~~

~~The following sections of Alberta Transportation 'Specifications for Bridge Construction' shall apply:~~

~~Section 3 'Bearing Piles'~~

~~Section 4 'Cast-In-Place Concrete'~~

~~Section 5 'Reinforcing Steel'~~

~~(1) General~~

~~The Contractor is to undertake geotechnical work at his own cost where necessary to ensure proper performance of the sign structure.~~

~~Any adjustments to the locations of sign structures will be subject to the acceptance of the Consultant.~~

~~The Contractor shall co-ordinate placement of the street light cable and conduit around the sign support foundation to avoid any conflicts.~~

~~Foundations shall be designed to allow for local frost conditions.~~

(2) — Material

~~(a) All reinforcing steel shall conform to CSA G30.18-M92 Grade 400.~~

~~(b) All concrete shall be Class C-35 MPa, with Type HS sulphate resistance cement.~~

~~24.2.1.8~~ ~~24.1.1.1~~ (3) — Anchor Rod Installation

~~Anchor rods shall be installed true and plumb in one complete assembly. The assembly shall be accurately positioned and secured to prevent movement or displacement during concreting procedures. No welding of any component is allowed.~~

~~The top anchor nuts shall have beveled washers if necessary to ensure full contact with the top of the column base plate. All structural bolts shall be tightened using the turn of nut method described in Subsection 6.3.2.6, High Tensile Strength Bolted Connections.~~

24.2.4.4 Anchor Rod Nut Tightening

~~Anchor rod nuts shall be tightened using the turn of nut method described in Subsection 6.3.2.6, High Tensile Strength Bolted Connections, except that anchor rod nuts shall be tightened an additional  $\frac{1}{3}$  turn of the nut past the snug-tight condition after the grout has attained sufficient strength. No regardless of anchor bolt length or diameter.~~

~~The top anchor rod nuts shall be allowed in full contact with the top of the column base plate.~~

~~Nuts will not be permitted under the base plate plates. All voids including the slots and annular space around anchor rods in the base plate shall be filled with an approved corrosion inhibiting paste acceptable to the Consultant.~~

(4) — Grout Pockets and Grout Pads

~~The Contractor shall fill the grout pockets and construct the grout pads using Sika 212 flowable grout or approved equivalent. Filling of grout pockets and construction of grout pads shall be done by workers competent in this work. The grout pocket shall be 25 mm deep and the total grout thickness shall not be less than 75 mm.~~

~~Grout shall be packaged in waterproof containers with the production date and shelf life of the material shown. It shall be mixed, placed, and cured in strict accordance with the Manufacturer's recommendations.~~

~~The method of forming and pouring the grout shall be submitted to the Consultant for acceptance. Dry pack methods of constructing grout pads will not be accepted.~~

(5) — Protection of Sign Structures

~~The Contractor shall erect the sign structure in a manner that addresses all safety issues including the interim period between erection grouting and final tightening of anchor rod nuts.~~

~~After erection of the sign structures, the Contractor shall place grout pockets and pads and tighten anchor rod nuts as soon as possible after grout has achieved sufficient strength. However the Contractor shall provide adequate safe traffic accommodation until tightening and grouting is complete.~~

~~(6) Grouting in Cold Weather~~

~~When the daily minimum air temperature or the temperature of the girders, bearings or substructure concrete in the immediate area of the grouting is, or is expected to be below 5°C during the placing and curing period, the following provisions for cold weather grouting shall be applied:~~

- ~~(a) Before grouting, adequate preheat shall be provided to raise the temperature of the adjacent areas of the girders, bearings and substructure concrete to at least 15°C.~~
- ~~(b) Temperature of the grout during placing shall be between 10°C and 25°C.~~
- ~~(c) The grout pads shall be enclosed and kept at 15°C to 25°C for a minimum of five days. The enclosure shall meet the requirements of Section 4 of the Specifications for Bridge Construction for concreting in cold weather.~~

~~(7) Clean-Up~~

~~All steel shall be left clean and free of oil, grease, mud, dust, road spray or other foreign matter.~~

**24.3 ~~24.3~~—Sign Panels**

The Contractor shall supply and install overhead sign panels as shown on the ~~plans and Drawings and in accordance with this specification.~~

24.3.1 Sign Panel and Connection Design Notes, Independent Checker Notes and Shop Drawing Submission Requirements

~~Sign panel and connection design notes, independent check notes and shop drawing submission requirements shall be in accordance with the requirements specified herein, Subsection 24.2.2.3.2, Overhead Sign Structure Design Notes, Independent Check Notes, and Shop Drawing Submission Requirements and this Subsection. As a minimum, the following information shall be included on sign panel shop drawing submissions:~~

~~24.3.1—Shop Drawings~~

- ~~• The Contractor shall provide the Consultant with three copies of the shop drawings showing the Number, spacing and locations of the aluminum T-section sections required for each sign panel(s);~~
- ~~• Assembly and mounting details. These drawings shall also detail the required;~~
- ~~• Method of attaching the sign panels to the sign support arms; and~~

~~The Consultant's review of the shop drawings shall not be construed as relieving the Contractor from his responsibility for errors or omissions in the calculations and drawings or for proper completion of the work in accordance with the Contract.~~

~~After the Consultant review, the Contractor shall revise the drawings and calculations as required to the satisfaction of the Consultant without any additional cost to the Department.~~

~~Fabrication shall not commence prior to the review of the shop drawings.~~

- ~~• 24.3.2 Location and number of slip arrest bolts.~~

#### ~~24.3.1~~ 24.3.2 Materials

Extruded aluminum panels shall be manufactured in accordance with Specification Subsection 5.18, Supply of Permanent Highway Signs, Posts and Bases ~~of the~~, Standard Specifications for Highway Construction, except as noted herein.

~~24.3.2.1~~ 24.3.2.1 Mill test reports for all materials shall be provided in accordance with Subsection 24.2.2.3.4, Mill Test Reports and Product Data Sheets, to the Consultant for review and acceptance.

#### ~~24.3.1.1~~ 24.3.2.1 Sheeting Materials

Reflective sheeting materials used on all overhead sign ~~and cantilever sign~~ structures shall be in accordance with Specification Subsection 5.18.2.8.2 ~~of the~~, Supply of Permanent Highway Signs, Posts and Bases, Standard Specifications for Highway Construction.

#### ~~24.3.1.2~~ 24.3.2.2 ~~24.3.2.2~~ Backing

Each panel shall be fabricated from a number of rows of extruded aluminum sections bolted together. Each row of a panel shall be fabricated from a single piece of extruded aluminum up to a maximum length of 6 ~~metres~~ m. Sign panels with a length in excess of 6 m can be split into multiple sections with a vertical joint that runs the vertical distance of the panel. The location of the vertical joint shall be chosen to minimize the number of letters/symbols split between the two sections. The number of sections for a panel shall be minimized.

A 1.0 cm wide x 2.5 cm long slotting shall be located on both edges of the extruded aluminum panels. The slotting shall be centered on the identification groove running longitudinally with the first slot centered 76 mm from the end of the section. The slotting shall be spaced on 152 mm centres for the entire length of the section.

#### ~~24.3.1.3~~ 24.3.2.3 ~~24.3.2.3~~ Extruded Aluminum Preparation

The extruded aluminum panels shall be clean of dust, dirt and/or grease. The method used for cleaning must not damage the anodized finish of the extruded aluminum panels or prevent the adhesion of the sheeting material to the extruded aluminum sections.



The ends of the extruded aluminum sections shall be checked to ensure that they are cut square to ensure flush joints between both panels and sections of a panel. The maximum allowable gap between two adjacent sections or panels shall be 5 mm. All excess material found along the slots and edges of the panels shall be removed.

The joint between two sections of a single panel shall be connected together with a T -stiffener when installed on the sign support structure. Care should be taken in choosing the vertical joint location to avoid conflicts between the joint T -stiffeners and the T -stiffeners used to attach the sign panels to the sign support structure.

Adjacent sign panels shall not be connected together by a joint T -stiffener or the T -stiffener used to attach the sign panel to the sign support structure.

~~24.3.1.4~~~~24.3.2.4~~ ~~24.3.2.4~~ Application of Sheeting Materials

The sheeting material (lettering, symbols, borders, background, etc.) shall be applied to the extruded aluminum sections as required by the sheeting manufacturer and as shown on the Plans. The horizontal line of lettering/copy across a joint between panels, or sections of a sign panel, shall be less than 8 mm.

Each panel, as shown on the Plans, shall be fabricated as an individual piece to facilitate future modifications. Large individual panels may be fabricated in multiple pieces as noted herein.

For sign panels where the background sheeting material is green and/or yellow, the sheeting is to be wrapped securely around the top and bottom horizontal edges of each extruded aluminum sub panel section. The outer edges of sheeting are to be neatly trimmed flush with the vertical edges of the sign panel.

~~24.3.2~~~~24.3.3~~ ~~24.3.3~~ Construction

Signs shall be shipped, stored and installed in a manner to prevent damage to the sign panels. Any damaged signs shall be repaired or replaced at no cost to the Department.

The Contractor shall erect the sign panels onto the overhead sign structures as shown on the PlansDrawings to ensure that the signs are located correctly over the indicated lanes and that the correct vertical clearance is maintained.

The Contractor shall provide the T -stiffeners, J -clips, bolts, flat washers, nylon insert lock nuts, slip arresting bolts and all of the necessary hardware to securely assemble the sign and connect the sign panels to the overhead sign structure as detailed on Alberta Transportation drawing TCS-A4-335A and shown on the accepted shop drawings.

Individual extruded aluminum sign sub panels shall be fastened together using stainless steel 10 mm diameter x 25 mm long bolts, nylon insert lock nuts, and with a washer under both the bolt head and the nut. The last slot of each joint between sections shall be bolted.

The bolting of the joint between the extruded aluminum sections shall be staggered between the rows of slots, except for the last slots at either end of the section or panel.

Sign panels shall be attached to the T -stiffeners using J -clip assemblies. The J -clip assembly consists of a J -clip bolt whose square head fits into the channels that run along either edge of an extruded aluminum section, a J -clip, a washer and a nylon insert lock nut. J -clip assemblies shall be placed where the edge/joint of the extruded aluminum sections meets a T -stiffener. The J -clip assemblies shall alternate sides of the T -stiffeners.

~~19mm~~19 mm diameter x 38 mm long stainless steel slip arresting bolts shall be provided with each sign ~~as follows:~~in accordance with Table 24-2, Slip Arresting Bolts Requirements

**Table 24-2: Slip Arresting Bolts Requirements**

<b>Number of Standard Height Sub Panels In Sign</b>	<b>Overall Maximum Sign Height (mm)</b>	<b>Number of Slip Arresting Bolts Per Each End of Each Sign</b>
< 9	2745	2
10-13	3965	4
14-17	5185	6

Stainless steel slip arresting bolts and nuts shall meet the requirements of Type 316 ASTM F593H and Type 316 ASTM F594H respectively with a minimum yield strength of 310 MPa and a minimum tensile strength of 585 MPa. A stainless steel washer shall be provided under the nut side of the bolt. Slip arresting bolts shall have nuts tightened to a torque of 181 Nm.

All joiner bolts and J -clip nuts must be tightened to a torque ~~to~~ 26.5 Nm within a tolerance of  $\pm 0.5$  Nm.

The face of the sign panels shall be cleaned ~~prior to acceptance~~to the satisfaction of the Consultant.

#### **24.4 24.4—Clean Up**

All overhead sign structures and panels shall be left clean and free of oil, grease, mud, dust, road spray or other foreign matter.

#### **24.424.5 Measurement and Payment**

##### ~~24.4.1—Sign Structure~~

##### ~~24.5.1—Payment for Supply and Install~~Overhead Sign Structures

Payment will be made at the lump sum price bid for “Overhead Sign Structure – Supply and Install”, for the specified structure. Such payment applicable bridge file, and will be considered full compensation for the design and, supply and fabrication of the structure; construction of the foundation and sign structure, fabrication,; erection and the furnishing of of the structure; installation; supply and installation of grout; and all labour, materials, labour, equipment, tools, and incidentals necessary to complete the Work as shown on the Drawings and to the satisfaction of the Consultant.

24.4.2—80% of the lump sum price bid will be paid once the foundations have been acceptably installed and the overhead sign structure has been acceptably supplied and delivered to the project site. The remaining 20% of the lump sum price bid will be paid once the overhead sign structure has been acceptably installed and grouted.

All costs associated with grouting in cold weather, when required, will be considered incidental to the Work, and no separate or additional payment will be made.

### Sign Panels~~Sign Panels~~

#### 24.5.2 Sign panels

Measurement for overhead payment of sign structures panels will be measured in by the square metres based on surface area for the extruded aluminum sign panels acceptably supplied and metre of panel installed, measured to the nearest 0.1 m<sup>2</sup>.

Payment for Supply and Install Sign Panels – Extruded Aluminum Payment will be made at the unit price bid per square metre. Such payment for “Sign Panels – Extruded Aluminum – Supply and Install”, for the applicable sign panels, and will be full compensation for the design, supply and fabrication; installation of the sign panels; and all labour, materials, labour, equipment, tools, and incidentals necessary to complete the Work as shown on the Drawings and to the satisfaction of the Consultant.

#### **24.5—Warranty**

The Contractor shall warrant that sign structures and panels are free from defect (material and workmanship) for a two year period in accordance with Specification 1.2.54 of the General Specifications.



# STANDARD SPECIFICATIONS FOR BRIDGE CONSTRUCTION

## SECTION 25 MECHANICALLY ~~STABILIZED~~STABILIZED EARTH WALLS

### TABLE OF CONTENTS

<b>25.1</b>	<b>General</b>	<b>25-1</b>
<b>25.2</b>	<b>Design</b>	<b>25-1</b>
25.2.1	General	25-1
25.2.2	Drainage	25-2
25.2.3	Geometric Requirements	25-3
25.2.4	Vertical Slip Joints	25-4
25.2.5	Obstructions	25-5
25.2.6	Precast Concrete Fascia Panels	25-5
25.2.7	Cast-In-Place Concrete Wall Coping Cap	25-6
25.2.8	Inspection Components	25-6
25.2.9	Design Notes, Independent Check Notes, and Shop Drawing Submission Requirements	25-7
<b>25.3</b>	<b>Materials</b>	<b>25-9</b>
25.3.1	Mill Test Reports	25-9
25.3.2	Concrete	25-9
25.3.3	Reinforcing Steel for Concrete	25-10
25.3.4	Steel Soil Reinforcement, Connections and Hardware	25-10
25.3.4.1	Galvanizing	25-10
25.3.5	Geosynthetic Soil Reinforcement	25-10
25.3.6	Safety Railings	25-11
25.3.7	Backfill	25-11
25.3.8	Geotextile Filter Fabric	25-14
25.3.9	Impermeable Geomembrane	25-14
25.3.10	Type 1c Concrete Sealer	25-15
25.3.11	Precast Concrete Fascia Panel Installation Shims	25-15
<b>25.4</b>	<b>Precast Concrete Fascia Panel Fabrication</b>	<b>25-15</b>
<b>25.5</b>	<b>Construction</b>	<b>25-16</b>
25.5.1	General	25-16
25.5.2	Conformance Criteria	25-17
25.5.3	Excavation	25-17
25.5.4	Concrete Leveling Pads	25-18
25.5.5	Backfilling	25-19
25.5.6	Precast Concrete Fascia Panel Installation	25-20
25.5.7	Cast-in-Place Concrete Wall Coping Caps	25-21
25.5.8	Impermeable Geomembrane	25-21
25.5.9	Safety Railings	25-21
25.5.10	Material Storage	25-22
25.5.11	Drainage Management during Construction	25-22
<b>25.6</b>	<b>Measurement and Payment</b>	<b>25-22</b>



## 25.1 General

This specification is for the design, supply, fabrication and construction of single stage mechanically stabilized earth (MSE) retaining walls with precast concrete fascia panels. MSE retaining walls shall include, but not be limited to, excavation for the wall, concrete leveling pads, precast concrete fascia panels, compacted granular backfill, soil reinforcement, inspection wires, perforated drain pipe complete with filter fabric sock, geotextiles, geomembranes, surface drains, cast-in-place concrete wall coping, ~~traffic barrier, pedestrian railing cap,~~ permanent safety railing, hardware and all associated materials.

~~Two stage~~ MSE retaining walls ~~shall be designed~~ are not permitted.

~~The precast concrete fascia panels, soil reinforcement, connections, inspection wires, hardware and constructed in accordance with the provisions contained herein and as determined by the Department and the Consultant.~~

~~The Contractor shall supply all necessary associated materials. All components of the MSE wall system shall be supplied from one a single MSE wall supplier.~~

## 25.2 ~~25.2~~ Design

### 25.2.1 ~~25.2.1~~ General

Location, layout, geometry control, short and long term global stability, allowable rate of fill placement, and allowable bearing capacity requirements shall be as specified in the Contract documents. The Contractor's design responsibility shall include internal and external stability (sliding and overturning), tensile resistance, pullout resistances, and all other elements for a complete MSE wall system. The Contractor shall check confirm the global stability design using actual soil properties ~~upon confirmation~~ of the ~~source of~~ backfill that will be used in the Work.

If the wall system selected by the Contractor requires modification to any component of the project, the Contractor will be solely responsible for all associated costs required to complete the change. Proposed changes ~~to the project~~ shall be submitted to the Consultant and the Department for review and acceptance a minimum of 3 weeks prior to commencement of detailed design.

The most stringent requirements of the following standards shall be met:

- Alberta Transportation Bridge Structures Design Criteria;
- ~~Alberta Transportation Roadside Design Guide~~
- ~~CAN/CSA S6 – Canadian Highway Bridge Design Code (CHBDC);~~
- AASHTO LRFD Bridge Design Specifications; and
- Alberta Transportation Roadside Design Guide.

The Federal Highway Administration (FHWA) publication, Design and Construction of Mechanically Stabilized Earth Walls and Reinforced Soil Slopes – Volumes 1 and 2 FHWA-NHI-10\_024 and FHWA-NHI-10\_025, is a recommended design reference.

MSE wall embedment depths shall not be less than provided in Table C11.10.2.2.1 "Guide for Minimum Front Face Embedment Depth" in the AASHTO LRFD Bridge Design Specifications Commentary, and in addition shall not be less than 1 m.

The design life for all MSE wall system components shall be 100 years.

~~Typical detail drawings illustrating some of the design requirements outlined in the following sections are available in the Alberta Transportation Bridge Structures Design Criteria Appendix D, SK16 through SK19.~~

#### 25.2.2 ~~25.2.2~~ Drainage

~~Water carrying appurtenances, such as catch basins, drainage inlets/outlets, culverts etc., shall be placed away from, or beyond the ends of the soil reinforcement zone, and provisions shall be made to mitigate the detrimental effects of potential leakage.~~

All galvanized steel soil reinforcement shall be protected from exposure to roadway de-icing salt by an impermeable geomembrane placed above the top layer of soil reinforcement. ~~The membrane shall be sealed to prevent leakage, sloped to drain away from the bridge or~~ This shall include soil reinforcement directly below a roadway, as well as immediately adjacent to the roadway for a minimum of 5 m measured perpendicular from the outer edge of roadway shoulder. In addition, for MSE walls that run parallel to the roadway, impermeable geomembrane shall be provided to intercept any drainage from the roadway base layer and direct it away from all MSE walls.

Geomembranes shall be sloped at a minimum of 5% to drain away from the bridge and wall and be connected to an outlet beyond the MSE soil mass. A non-woven geotextile filter fabric layer shall be placed below and above the ~~membrane to prevent puncture.~~ geomembrane to prevent puncture. In all cases the geomembrane material shall be made continuous and water-tight, and shall extend a minimum of 500 mm beyond the extent of the steel soil reinforcement. Any necessary seams shall be shingled in the direction of drainage and welded or bonded to prevent leakage. Specific designs may warrant the use of roughened surface impermeable geomembranes.

Weep drains consisting of flexible perforated 150 mm diameter pipe complete with filter sock shall be provided near the front and the back bottom corner of the MSE soil mass. Weep drains shall be day lighted or connected to an outlet to establish positive drainage.

Downspouts shall be provided for deck joint and deck wick drain drainage- directly in front of the MSE wall precast concrete fascia panels. Downspouts shall be rigid PVC type DB2 conduit meeting the requirements of CSA C22.2 No. 211.1. Couplers shall be solvent bell ends (SBE). Downspouts shall have a vertical slip joint with a dished top drain inlet cast into the cast-in-place wall coping cap. Downspouts shall not be directed through the mechanically stabilized earth mass. Down spouts shall be recessed full height in a chase formed into the front of precast concrete fascia panels or by using special fascia panels and covered with a 10-gauge or 2.6 mm thick steel plate. The plate shall be shop painted with a system selected from the SS1 or SS2 category of the Department's list of approved coating systems. Surface preparation shall be in accordance with the selected coating systems published product data sheet.



~~The run of MSE walls shall slope away from bridge abutments.~~ Grassed swales with a non-degradable erosion control mat shall be provided behind the top of MSE cast-in-place concrete wall coping cap, beyond the footprint of the bridge deck, and shall have a minimum width of 600 mm, a minimum depth of 150 mm, and a minimum ~~depth of 150 mm.~~ longitudinal (parallel to the face of the wall) slope of 0.5%.

Concrete swales of the same dimension as grassed swales shall be provided behind the top of MSE cast-in-place concrete wall coping cap within the footprint of the bridge deck. Closed cell foam of adequate thickness to accommodate thermal movements shall be provided between ~~the~~ concrete ~~swales~~ and integral concrete bridge abutments. The closed cell foam shall be of a density that will not cause damage to adjoining components and meet all design service life requirements. A 10 mm thick asphalt impregnated fibre board shall be placed between the concrete swale and semi-integral or conventional concrete bridge abutments. Swales shall have a bottom liner of impervious geomembrane.

~~When a headslope is provided between the bridge abutment and concrete swale it shall be protected with concrete slope protection. Isolation with closed cell foam or asphalt impregnated fibre board shall be provided between the top of the concrete slope protection and abutment concrete as described above.~~

### ~~25.2.3~~ Barriers/Railings

~~In locations where traffic runs adjacent to the top of, and nominally parallel to a MSE wall, a rigid bridge barrier shall be provided that meets the appropriate Performance Level requirements of the CAN/CSA S6 CODE Section 12 — Barriers and Highway Accessory Supports. Flexible guardrail systems shall not be used. The MSE wall shall be designed to fully resist the collision loads applied to the barrier, and loads from any attachments such as sign supports and lamp posts. All obstacles, such as sign supports and lamp posts, shall meet set-back and clearance requirements specified in the Alberta Transportation Roadside Design Guide. The barriers shall be located on top of the MSE wall, and supported on a moment slab to resist sliding and overturning. Approach rail transitions shall be provided at either end of the rigid bridge barrier as outlined in the Alberta Transportation Roadside Design Guide. Details for the Department's standard PL-2 Barrier System on top of MSE walls can be found on standard drawing S-1798.~~

~~In locations where a sidewalk or a combined pedestrian/cyclist use pathway runs adjacent to the top of, and nominally parallel to a MSE wall, a pedestrian/cyclist railing shall be provided that meets the requirements of the Alberta Transportation Bridge Structures Design Criteria Section 21.2 — Pedestrian/Cyclist Railing. The MSE wall shall be designed to fully resist the loads applied to the railing, and loads from any attachments such as sign supports and lamp posts. The railing shall be mounted on the top surface of the concrete coping of the MSE wall.~~

~~Unless a traffic barrier or a pedestrian/cyclist railing is mounted directly on top of a MSE wall, a safety railing shall be mounted on the top surface of the concrete coping of the MSE wall and shall be designed as a “guard” in accordance with the Alberta Building Code, Part 9. Safety railings shall have a minimum height of 1070 mm and shall consist of vertical posts with not less than two horizontal rails. Chain link fence shall not be used. Safety railing anchorage assemblies shall be cast within concrete coping and not field drilled. The MSE wall shall be designed to fully resist the loads applied to the railing.~~

~~In locations where traffic is running adjacent to the bottom of, and nominally parallel to a MSE Wall, and where thriebeam approach rail transitions are anchored to one or both ends of the MSE wall, anchor blocks with sufficient strength shall be provided for anchoring of the thriebeam transitions where they connect to the ends of the MSE wall.~~

#### ~~25.2.4 Miscellaneous Details~~

~~Obstructions such as foundation piles and associated casings, or casings for future pile installations in the soil reinforcement zone, shall be accommodated with appropriate arrangement of soil reinforcement around such obstructions. For those MSE wall systems that lend themselves to splaying of the soil reinforcement, the splay angle shall not exceed 20° from perpendicular to the facing panel. For other MSE wall systems, coverage ratios of soil reinforcement shall be specifically developed for each project.~~

#### 25.2.3 Geometric Requirements

All MSE walls shall be designed so that in the final position, they will be battered back against the retained soil from a vertical plumb line by a ratio of 50 vertical units to 1 horizontal unit. MSE precast concrete fascia panels shall be fully supported by compacted backfill without voids on the non-exposed side.

The geometry of MSE walls, including associated headslopes and embankments, shall be sloped so that all drainage is directed away from bridge abutments.

MSE wall backfill shall extend a minimum of 0.5 m beyond the end of the soil reinforcement.

Concrete leveling pads shall be used and project a minimum of 75 mm ~~either side~~beyond both sides of the precast concrete fascia panels. Precast concrete fascia panels shall be centered on the concrete leveling pad. For stepped leveling pads, the maximum elevation difference between adjacent steps shall not exceed 1250 mm. The minimum length of each stepped section shall be ~~4500~~2500 mm.

Acute corners less than 70° (measured between backfill sides of precast concrete fascia panels) are not permitted. Special corner panels shall be used to maintain the 20 mm nominal design joint gap along the front face of panels on either side of the bend line.

~~All MSE walls~~Soil reinforcing details shall be ~~battered back 50~~designed to 4-accommodate the requirements in Subsection 25.5.5, Backfilling, for overlapping reinforcing.

#### 25.2.4 Vertical Slip Joints

In instances where a continuous length of MSE wall cannot be built all at the same time as a result of an existing obstruction (e.g. existing bridge, or existing roadway, etc.), the continuous length of MSE wall panels may be divided into multiple sections and some or all of the sections constructed at different times. In such instances, a full height vertical slip joint, acceptable to the Consultant and the Department, shall be fully supported by compacted backfill without voids on the non-exposed side.

~~All provided between adjacent MSE walls shall have a wall sections. This manner of staging MSE wall construction shall not be confused with two stage MSE wall construction, which is not permitted.~~

~~The cast-in-place concrete wall coping running the full length of the top of the wall. The top of the coping shall be smooth, have no steps or abrupt changes in height, and a 3% wash slope towards the back of the wall. Copingscap shall have a drip groove located in the soffit and controlbe designed with vertical joints. Drip groove and control joints shall be detailed in accordance with Standard Drawing S-1680 "Standard Curb Details". Control joints shall be located at in line with the precast concrete fascia panel joints, and with horizontal reinforcement in the cap made discontinuous at these vertical joints.~~

### 25.2.5 Obstructions

~~Obstructions within the mechanically stabilized earth mass, such as foundation piles and associated casings, casings for future pile installations, or other obstructions, shall be accommodated with appropriate arrangement of soil reinforcing around such obstructions. For those MSE wall systems that splay the soil reinforcement, the splay angle shall not exceed 15° from the perpendicular to the wall direction and in no case exceed 4 m spacing. At control joints, longitudinal reinforcing of the precast concrete fascia panel. For other MSE wall systems, coverage ratios of soil reinforcement shall be discontinuous specifically developed for each wall location within the Contract and have a 50 mm concrete cover measured from the center of the jointdesign calculations included in the design notes and check notes submissions.~~

### 25.2.6 Precast Concrete Fascia Panels

Precast concrete fascia panels shall have a minimum thickness of 140 mm, excluding any additional thickness required for aesthetic surface treatments. The minimum cover to reinforcing steel shall be 50 mm from all faces., and steel reinforcing bars shall be electrically isolated from steel connection hardware and/or steel soil reinforcement.

Joints between panels shall have a lip and recess (ship lap) configuration. Butt joints may be used if a precast HPC concrete backing block with filter fabric is designed and installed along the joint to prevent soil infiltration. Backing blocks shall overlap adjacent panels a minimum of ~~200~~150 mm and have a minimum thickness of 140 mm.

Precast concrete fascia panels shall be designed to accommodate a differential settlement of 100 mm in 10 metresm of length along the wall. The gap spacing between adjacent precast concrete fascia panels shall be designed to be 20 mm nominal. ~~Where staged construction is required, and large differential settlement is expected between stages, appropriately located full height vertical slip joints shall be provided.~~

To facilitate construction of the cast-in-place concrete wall coping cap pre-formed holes in precast concrete fascia panels are permitted provided the holes are located a minimum of 100 mm above the cast-in-place wall coping cap soffit.

~~Acute wall corners less than 70° (measured between backfill sides of panels) shall not be used. Special corner panels shall be used to maintain the 20 mm nominal design joint gap along the front face of panels on either side of the bond line.~~

A minimum 300 mm wide strip of filter fabric shall be installed behind all precast concrete fascia panel joints. ~~An~~ Adhesive shall be used to hold the fabric securely against the panels centered on the vertical and horizontal joints. Details proposed shall be submitted to the Consultant for review and acceptance prior to commencement of the Work. At MSE wall corners, the fabric shall be installed in one piece crossing the corner joint.

#### 25.2.7 25.2.5 ~~Cast-In-Place Concrete Wall Coping Cap~~

A cast-in-place concrete wall coping cap is required on the top of all MSE walls, unless the section of MSE wall requires a cast-in-place concrete barrier slab.

The top of the cast-in-place wall coping cap shall be smooth, have no steps or abrupt changes in height, and a 3% wash slope towards the MSE soil mass. Control joints and drip grooves shall be detailed in accordance with Standard Drawing S-1680, Standard Curb Details. Control joints shall be located at the centerline of the precast concrete fascia panel joints, perpendicular to the wall direction and in no case exceed 4 m spacing. At control joints, longitudinal reinforcing in the cast-in-place wall coping caps shall be discontinuous and have a 50 mm concrete cover measured from the center of the joint.

The MSE wall and cast-in-place wall coping cap shall be designed to fully resist the loads specified on the Drawings that are applied to the roadway barriers, railings or any attachments.

#### 25.2.3~~25.2.8~~ Inspection Components

An inspection access walkway shall be provided full width of the bridge superstructure in front of the abutment seat and on top of MSE abutment walls. The inspection access walkway shall have a minimum vertical clearance of 1200 mm under the girders and a minimum clear width of 1000 mm.

Galvanized steel inspection wires shall be provided in all MSE wall systems in addition to the soil reinforcement design requirements. One inspection wire shall be provided for each 25 m<sup>2</sup> of wall area. Inspection wires shall be placed in vertically distributed sets of 2 or 3 depending on the wall height. Two locations shall be provided where the wall height is less than 6 m and ~~three~~ locations provided where the wall height is greater than 6 m. Vertical distribution shall be such that a single inspection wire is placed within the center of the bottom wall precast concrete fascia panel, center of the top wall precast concrete fascia panel, and in the center wall precast concrete fascia panel when ~~three~~ locations are required. Sets of inspection wires shall be evenly distributed along the length of the wall.

Inspection access ports, wire removal and centering devices shall be detailed in accordance with the California Department of Transportation standard bridge detail sheet XS13-020-3. Inspection access ports shall be cast as voids in the panels at the panel manufacturing facility and the remaining cavity placed and filled with an approved type OH-V patching product in accordance with the manufacturer's recommendations. All inspection access ports shall be marked with a 25 mm diameter galvanized or plastic survey target anchored into the patching material and flush with the wall surface. Adhesively mounted survey targets will not be permitted. Survey targets shall not receive pigmented sealer ~~when specified.~~

#### ~~25.2.6 Submissions and Consultant Review~~

#### 25.2.9 Design Notes, Independent Check Notes, and Shop Drawing Submission Requirements

Design notes, independent check notes, and shop drawings shall be ~~stamped,~~ signed and sealed by a the design engineer of record and by an independent checker. The design engineer of record and the independent checker shall be Professional ~~Engineer, Engineers~~ registered ~~to practice~~ in the Province of Alberta.

~~Design notes shall be presented in a legible and logical format, and shall be sufficiently detailed to allow a technical review of design concepts and assumptions used in the design. Where necessary, the design package shall be accompanied by properties of materials used together with the appropriate test certificates.~~

~~Shop drawings shall be legible and of adequate quality to be reproduced and microfilmed. Each drawing shall have sufficient blank space for the Consultant's acceptance stamp.~~

~~As a minimum, shop drawings shall contain:~~

- ~~• Alberta Transportation bridge file number and project name on each drawing.~~
- ~~• Design criteria and material lists.~~
- ~~• Backfill properties.~~
- ~~• Wall layout plan and elevation complete with dimensions and elevations, and typical wall cross-sections.~~
- ~~• All component and connection details.~~
- ~~• Site drainage and drainage details.~~

Two copies of the design notes and five copies of the Design notes, independent check notes and shop drawings shall be submitted to the Consultant for review and acceptance a minimum of 3 weeks in advance of ~~scheduled fabrication.~~ the commencement of fabrication. Review comments provided by the Consultant and/or the Department shall be incorporated into the design notes, independent check notes and shop drawings and resubmitted to the Consultant for review and acceptance prior to the commencement of fabrication.

The design engineer of record and independent checker shall submit separate signed and sealed design notes and independent check notes. The design and independent check notes shall be presented in a legible and logical format, clearly identify material properties, and sufficiently detailed to allow a technical review of design concepts and assumptions used. All material properties shall be confirmed and documented by the design engineer of record and independent checker prior to the commencement to fabrication.

The independent checker may be employed by the same company as the design engineer of record. The independent check must be completed fully independent of the design engineer of record, including a complete re-analysis of all aspects of the design including calculations and engineering, preferably by a methodology or computer program other than that used by the design engineer of record. The design engineer of record and independent checker shall ensure that the shop drawings are complete and accurately convey the design criteria and assumptions used in their designs.

Shop drawings shall be electronic unlocked PDF format. Each shop drawing shall include the Department's shop drawing identification block and have a sufficient blank space for the Consultant's review stamp. The Department's shop drawing identification block will be provided to the Contractor upon request. As a minimum, the following information shall be included on shop drawing submissions:

- Wall layout plan and elevation complete with dimensions and elevations, and typical wall cross-sections;
- Precast concrete fascia panel reinforcing, connection and hardware detailing;
- Cross references to relevant bridge design Drawings;
- Design criteria and list of material properties;
- Backfill properties;
- All component and connection details;
- MSE wall drainage details; and
- Construction procedures and construction sequencing.

The design notes, independent check notes, and shop drawings will be reviewed by the Consultant solely to ascertain general conformance with codes and specifications. Responsibility of the final design remains solely with the Contractor.—The Consultant's review and acceptance of the shop drawings shall not be construed considered as relieving the Contractor from hisof the responsibility for errors or omissions in the calculations and drawings or for the proper completion ofcompleting the Work in accordance with the Contract requirements.

~~After the Consultant's review, the Contractor shall revise the drawings and calculations as required to the satisfaction of the Consultant without any additional cost to the Department. Prior to commencing fabrication, all shop drawings shall be clearly signed by the Department's Consultant as verification that the Consultant has completed his review and accepted the Shop Drawings.~~

The Contractor shall incorporate as-built construction conditions ~~and submit revised into~~ design notes, independent check notes, and shop drawings ~~for records at the completion of construction~~. One paper copy and one electronic copy (PDF format) of ~~as constructed shop drawings, built~~ design notes, independent check notes, and supplier inspection shop drawings shall be submitted to the Consultant within 3 weeks of construction completion.

### **25.3 Materials records**

#### **25.3.1 Mill Test Reports**

Mill test reports shall be provided for all steel fabricated components, steel soil reinforcement, connections, and associated hardware in English. Material test reports shall be provided for geosynthetic soil reinforcement and impermeable geomembrane. Mill and material test reports shall be submitted to the Consultant within three weeks of wall completion for review and acceptance prior to being incorporated in the Work.

**25.3**—The Contractor shall maintain a tracking system and complete set of records for all steel fabricated components. Mill test reports at a minimum shall include: heat number, date, location of production, compliance with production standards, chemical analysis, mechanical properties, including galvanizing processes. Mill test reports shall be authenticated by the manufacturer.

Where mill test reports originate from a mill outside Canada or the United States of America, the Contractor shall have mill test reports verified by a certified laboratory in Canada by testing the material to the specified material standards, including boron content. The testing laboratory shall be certified to ISO/IEC 17025 by an organization accredited by the Standards Council of Canada for the tests required. Samples for testing shall be collected by personnel employed by the certified laboratory. A verification letter shall be provided by the certified laboratory that includes at a minimum, the applicable mill test reports, testing standards, date of verification testing, and declaration of material compliance with Contract requirements. The verification letter shall be signed by an authorized officer of the certified laboratory.

### **Materials**

#### ~~25.2.4~~ **25.3.2** ~~25.3.1~~ Concrete

Concrete for leveling pads shall be Class C. Concrete for precast concrete fascia panels, anchor blocks, backing blocks, cast-in-place concrete wall ~~copings~~ scoping caps, and all other concrete components shall be Class HPC. Concrete shall conform to the requirements of Section 4—"Cast-In-Place Concrete" of the Specifications for Bridge Construction. The maximum aggregate size for HPC concrete used in panel production shall suit the panel design and the requirements of ~~GAN/CSA S6 and GAN/CSA 23A~~ 23.1.

~~25.2.5~~25.3.3 ~~25.3.2 Concrete~~ Reinforcing Steel for Concrete

Reinforcing steel shall be in accordance with the requirements of Section 5-~~4~~ Reinforcing Steel.  
Steel ~~of the Specifications for Bridge Construction.~~

~~25.2.6~~25.3.4 ~~25.3.3~~ Soil Reinforcement, Connections and Hardware

Steel soil reinforcement, including inspection wires, consisting of welded wire reinforcement shall meet the requirements of ASTM A1064 and Steel soil reinforcement consisting of steel strip reinforcement shall meet the requirements of ASTM A572. Inspection wires shall meet the requirements of ASTM A1064. Connections and hardware shall meet the specified design life of 100 years.

Steel with a boron content exceeding 0.0008% will not be permitted.

25.3.4.1 Galvanizing

Steel soil reinforcement, connections and associated hardware shall be galvanized in accordance with ASTM ~~Standard A123/A123M and ASTM A153/A153M.~~ and F2329. Safeguarding measures to prevent embrittlement and testing to detect embrittlement shall be completed in accordance with ASTM A143 for all lots of steel soil reinforcement, connections and associated hardware.

Repair of galvanizing shall be completed in accordance ASTM A780, Method A3 "Metallizing" and will only be permitted when the repair areas are small and infrequent as determined by the Consultant. Repair areas less than 100 mm<sup>2</sup> in area may be completed in accordance with ASTM A780, Method A1 "Repair Using Zinc-Based Alloy". The thickness of the coating for both methods shall be 180 µm, and the repair tested for adhesion. A detailed repair procedure shall be submitted for review and acceptance by the Consultant prior to commencement of the work. Repairs may require complete removal of the galvanized coating and re-galvanizing.

Galvanized material shall be stacked or bundled and stored to prevent wet storage stain as per the American Hot Dip Galvanizers Association (AHDGA) publication "Wet Storage Stain". Any evidence of wet storage stain shall be removed to the satisfaction of the Consultant.

25.3.5 Geosynthetic ~~reinforcing~~Soil Reinforcement

Geosynthetic soil reinforcement shall meet AASHTO LRFD Bridge Design Specifications Clause 11.10.6.4.3b. The requirements "for applications involving severe consequences of poor performance or failure" shall apply. ~~Results of~~ Product specific durability studies shall be carried out to determine the product-specific long term strength reduction factor (RF) and shall be submitted for the Consultant's review and ~~approval~~acceptance. These studies shall be used to estimate the short term and long term effects of the environment factors on the strength and deformational characteristics of the geosynthetic reinforcement throughout the specified design life.



Geosynthetic reinforcing materials shall satisfy the requirements of the following tests with the understanding that the test methods are current at the time of construction:

- ~~GG-1~~ “ASTM D7737-11, Standard Test Method for Individual Geogrid Rib TensileJunction Strength”;
- ~~GG-2~~ “87, Standard Test Method for Geogrid Rib Junction Strength”;
- ~~GG-3~~ “ASTM D5262 - 07(2012), Standard Test Method for TensileEvaluating the Unconfined Tension Creep Testingand Creep Rupture Behavior of Geogrids”Geosynthetics;
- ~~GG-4~~ “GG4-05, Standard Practice for Determination of the Long Term Creep Design Strengths of Geogrids”;
- GG4(a) Revised 2012, Standard Practice for Determination of the Long-Term Design Strength of Stiff Geogrids;
- GG4(b) Revised 2012, Standard Practice for Determination of the Long-Term Design Strength of Flexible Geogrids; and
- ASTM D6706 - 01(2013), Standard Test Method for Measuring Geosynthetic Pullout Resistance in Soil.

Geosynthetic reinforcing materials shall contain stabilizers or inhibitors to prevent degradation of properties due to ultraviolet light exposure.

The nominal long-term reinforcement ~~material~~ design strength (Tal) values for specific products shall be determined by third party agencies such that as the Highway Innovative Technology Evaluation Centre (HITEC) or AASHTO National transportation Product Evaluation Program (NTPEP); and product lines shall be re-tested every 3 years at a minimum.

#### ~~25.3.4~~ Barriers/Railings

#### ~~25.3.6~~ All Safety Railings

Steel components of ~~traffic barriers, pedestrian/cyclist railings, and safety railings shall conform to CSA G40.21M Grade 300W, and shall be galvanized in accordance ASTM Standard A123/A123M and ASTM A153/A153M. Steel components of traffic barriers, pedestrian/cyclist railings, and safety railings shall be fabricated and galvanized in accordance with Section 12-“Bridgerail” of the Specifications for Bridge Construction. Safety railings shall conform to CSA G40.21M Grade 300W.~~

#### ~~25.2.7~~ 25.3.7 ~~25.3.5~~ Backfill

Backfill for construction of MSE walls shall be crushed aggregate material conforming to the gradation requirements listed in ~~the following table:~~ Table 25-1, Backfill Gradation Requirements, and shall be free of organic matter and other deleterious materials.

**Table 25-1: Backfill Gradation Requirements**

<u>Designation/Class</u> <u>Metric</u> <u>Sieve Size</u> <u>(CGSB 8-GP-2M)</u>	<u>Designation/Class</u>		
<u>Metric Sieve Size</u> <u>(CGSB 8-GP-2M)</u>	Crushed Aggregate Material Des 2 Class 20	Crushed Aggregate Material Des 2 Class 25	Crushed Aggregate Material Des 2 Class 40
Sieve Size $\mu\text{m}$	Percent Passing	Percent Passing	Percent Passing
125 000			
80 000			
50 000			
40 000	<u>100</u>	<u>100</u>	100
25 000	<u>100</u>	100	70 - 94
20 000	100	82 - 97	<del>----</del> n/a
16 000	84 - 94	70 - 94	55 - 85
10 000	63 - 86	52 - 79	44 - 74
5 000	40 - 67	35 - 64	32 - 62
1 250	22 - 43	18 - 43	17 - 43
630	14 - 34	12 - 34	12 - 34
315	9 - 26	8 - 26	8 - 26
160	5 - 18	5 - 18	5 - 18
80	2 - 10	2 - 10	2 - 10
% fractures by weight (2 faces)	60+	60+	50+
Plasticity Index	<u>NP - 6</u>	NP - 6	NP - 6
L.A. Abrasion Loss Percent Maximum	<u>50</u>	50	50

~~The MSE wall supplier shall use Laboratory density testing shall be completed in accordance with ASTM D698 on the selected backfill source(s) and provided in the submission requirements outlined in Subsection 25.2.9, Design Notes, Independent Check Notes, and Shop Drawing Submission Requirements.~~

The physical properties of the MSE wall backfill material selected by the Contractor from Table 25-1 shall be used by the MSE wall supplier in his detailed design ~~of the MSE wall.~~

In no case shall any backfill placed within 2.0 m of the face precast concrete fascia panels have more than 5% passing the 0.080 mm (80 µm) sieve size.

Soil filters between soil zones shall be designed based on the properties of the adjacent materials.

The selected backfill shall also meet the following parameters requirements of Table 25-2 or Table 25-3, based on soil reinforcement type used in the MSE wall system:

-

**BACKFILL REQUIREMENTS FOR GALVANIZED STEEL Table 25-2: Backfill Requirements for Galvanized Steel Soil Reinforcing**

Backfill Requirement		Test Method (ASTM)	Test Method (AASHTO)
Resistivity	≥3000 ohm-cm	G57	T 288
pH	5 - 10	G51	T 289
Chlorides	≤100 ppm	D512	T 291
<u>Magnesium Sulphate Soundness</u>	<u>Loss less than 30% after four cycles</u>	<u>D5240</u>	<u>T 104</u>
Sulphates	≤200 ppm	D516	T 290
Organic Content	≤1.0%	D2974	T 267

**BACKFILL REQUIREMENTS FOR GEOSYNTHETIC Table 25-3: Backfill Requirements for Geosynthetic Soil Reinforcing**

Backfill Requirements		Test Method (ASTM)	Test Method (AASHTO)
pH	3 - 12	G51	T 289
Organic Content	≤1.0%	D2974	N/A
Design Temperature at Site	≤ <u>30°C</u>	N/A	N/A

Collection of samples for testing shall be from proposed stockpiles at the top, middle and bottom portions, approximately 0.6 m in from the face of the stockpile. Resistivity testing shall be completed on 6 samples (2 top, 2 middle, 2 bottom). PH, chloride, sulphate, and organic content testing shall be completed on 9 samples (3 top, 3 middle, 3 bottom).

~~25.2.8~~ ~~25.3.8~~ ~~25.3.6~~ Geotextile Filter Fabric

Non-woven geotextile filter fabric shall ~~comply with~~ meet the ~~following minimum physical properties: requirements specified in Table 25-4, Non-woven Geotextile Filter Fabric Requirements.~~

**Table 25-4: Non-woven Geotextile Filter Fabric Requirements**

<b>Fabric Requirements Physical Property</b>	<b>Test Method (ASTM)</b>	<b>Minimum Required Value</b>
<u>Grab Strength</u>	<u>D4632</u>	<u>650 N</u>
<u>Elongation – Failure</u>	<u>D4632</u>	<u>50 %</u>
<del>Grab Strength</del> <del>Elongation – Failure</del> CBR Puncture Strength <del>Trapezoidal Tear</del>	<del>D6241</del> <u>≥ 650 N</u> <u>≥ 50%</u> <del>≥ 275 N</del> <del>≥ 250 N</del>	<u>250</u> <del>N</del> <u>D4632</u> <del>D4632</del> <u>D6241</u> <del>D4533</del>
<u>Trapezoidal Tear</u>	<u>D4533</u>	<u>275 N</u>

The minimum fabric lap length shall be 300 mm.

~~25.2.9~~ ~~25.3.9~~ ~~25.3.7~~ Impermeable Geomembrane

Impermeable geomembrane shall be PVC, HDPE or LLDPE with a minimum thickness of 0.75 mm, and ~~comply with~~ meet the ~~following minimum physical properties: property requirements outlined in Table 25-5, Impermeable Geomembrane Requirements.~~

**Table 25-5: Impermeable Geomembrane Requirements**

<b>Impermeable Geomembrane Requirements Physical Property</b>	<b>Test Method (ASTM)</b>	<b>Minimum Required Value</b>
<u>Tear Strength</u>	<u>D1004</u>	<u>45 N</u>
<del>Tear Strength</del> CBR Puncture Strength	<del>D6241</del> <u>≥ 45 N</u> <u>≥ 140 N</u>	<u>140 N</u> <del>D1004</del> <u>D6241</u>

~~Specific designs may warrant the use of roughened surface geomembranes. The membrane shall be installed in accordance with the manufacturer's recommendations. All seams in the membrane shall be welded or bonded to prevent leakage.~~

~~25.2.10~~ ~~25.3.10~~ 25.3.8 Type 1c Concrete Sealer

Type 1c sealer shall be applied to exposed concrete surfaces in accordance with Section 4 ~~of the Specifications for Bridge Construction, Cast-In-Place Concrete.~~

25.3.11 ~~25.4~~ Precast Concrete Fascia Panel ~~Fabrication~~ Installation Shims

All proposed permanent shims used in precast concrete fascia panel installation shall meet the specified design life of the MSE wall.

~~25.3~~ 25.4 Precast Concrete Fascia Panel Fabrication

The fabrication of precast concrete fascia panels shall be in accordance with Section 7 ~~“Precast Concrete Units” of the Specifications for Bridge Construction, CAN/CSA A23.4, and as modified by this section.~~ In the case of conflicting requirements the hierarchy of governing requirements shall be as follows: Section 25, Mechanically Stabilized Earth Walls, Section 7, Precast Concrete Units and CSA A23.4.

The concrete materials used in the fabrication of precast concrete fascial panels shall meet the requirements of Subsection 25.3.2, Concrete.

All edges of precast concrete fascia panels shall be chamfered.

Geosynthetic reinforcing embedded into precast concrete fascia panels shall ~~exit perpendicular~~ be facilitated using structural steel jigs to maintain alignment and projection lengths. Geosynthetic reinforcing embedded into precast concrete fascia panels shall exit perpendicular to the precast concrete fascia panel unless otherwise reviewed and accepted by the Consultant and the Department. Geosynthetic reinforcing tabs exiting precast concrete fascia panels shall have uniform projection length.

Concrete shall have a minimum strength of 18 MPa prior to formwork removal.

Exposed precast concrete fascia panels shall be finished in accordance with Section 4 ~~of the Specifications for Bridge Construction, Cast-In-Place Concrete~~ with the exception that all required surface cavities shall be filled with a Department approved concrete patching material. The entire exposed panel fascia finish texture shall be a form finish and not a washed or rubbed finish.

Precast concrete fascia panels with the following defects shall be rejected, ~~and new panels provided:~~

- Units with variation in precast concrete fascia panel face trueness for any line across a precast concrete fascia panel face from a straight edge exceeding more than 2 mm over 1 m;

- Units with honeycombing, cracks, spalls or broken corners;
- Units with more than 10 surface cavities per ~~square metre~~<sup>m<sup>2</sup></sup> with cavity diameters from 2 mm up to 5 mm;
- Units with more than three surface cavity per ~~square metre~~<sup>m<sup>2</sup></sup> with cavity diameter from 5 mm up to 10 mm; and
- Units with any surface cavities greater than 10 mm in diameter.

Inspection and assessment of surface cavities shall be carried out by the Contractor immediately after stripping of forms. Surface cavities of 5 mm or less on precast concrete fascia panels meeting the above ~~acceptance~~ criteria will not require further repair.

Repair of surface cavities shall be completed in a sheltered environment ~~and~~ with a minimum ambient temperature of ~~40°C~~<sup>10°C</sup>. Saturation of the face of the precast concrete fascia panels in preparation for the repair of surface cavities shall begin immediately after stripping. During repair of surface cavities, and up to the start of elevated temperature curing or moist curing, panel faces shall be kept in a continuously ~~wet~~<sup>saturated surface dry</sup> condition. As an alternative to moist curing with filter fabric, precast concrete fascia panels may be moist cured in an enclosure with controlled temperature and humidity such that all exposed concrete surfaces remain saturated for the duration of the curing period. If stacked during curing, sufficient space shall be maintained between panels to permit airflow and inspection of surfaces.

#### ~~25.4~~<sup>25.5</sup> ~~25.5~~ — Construction

##### ~~25.4.1~~<sup>25.5.1</sup> ~~25.5.1~~ — General

The Contractor shall employ qualified personnel experienced in constructing MSE walls to supervise and perform the work. Construction of the MSE wall system shall conform to the shop drawings, supplier's ~~recommendations~~<sup>submitted construction procedures and construction sequencing</sup>, and these specifications.

The Contractor shall also require the supplier of the MSE wall system to provide a full-time qualified representative on site during construction to advise the Contractor's personnel regarding construction procedures and to monitor that construction is being completed in accordance with the shop drawings and the supplier's ~~recommendations~~<sup>submitted construction procedures and construction sequencing</sup>.

A milestone construction meeting for MSE wall construction shall be held prior to the commencement of the Work. The agenda shall be developed by the Contractor and MSE wall supplier and reviewed and accepted by the Consultant prior to scheduling the meeting. The Contractor's project manager, MSE wall construction superintendent, MSE wall design engineer of record, MSE wall supplier construction representative, and any other personnel directly involved in supervision of the Work shall attend the milestone construction meeting.

The Contractor shall provide the Consultant with a weekly summary report detailing daily construction activities and compliance. Work that is not in compliance with the accepted shop drawings ~~or supplier's recommendations, construction sequencing and procedures,~~ shall be ~~reported~~corrected immediately to the full satisfaction of the Consultant ~~immediately.~~

~~MSE wall components that are damaged during any construction operation shall be removed and replaced at the Contractor's expense.~~

#### ~~25.4.2~~25.5.2 ~~25.5.2~~ Conformance Criteria

The Contractor and MSE Wall design engineer of record shall provide formalized documentation, sealed and signed by the Professional Engineer registered in the Province of Alberta, for each of the following construction phases confirming compliance with all Contract requirements:

- Foundation base preparation;
- On-site delivery of all MSE wall components;
- Backfill requirements;
- Alignment of precast wall-concrete fascia panels; and
- ~~Backfill requirements~~
- 25.5.3 Wall alignment and tolerance measurements.

The Contractor shall maintain soil reinforcing placement records, soil compaction records, and precast concrete fascia panel alignment and tolerance measurement records throughout MSE wall construction.

MSE wall components that are damaged during any construction operation shall be repaired or replaced at the Contractor's expense as outlined in these specifications and completed to the full satisfaction of the Consultant.

#### 25.5.3 Excavation

Excavation for the MSE wall shall be carried out in conformance with Section 1, Excavation, and these specifications. In the case of conflicting requirements the requirements of this specification shall govern.

The Contractor shall establish the locations and extents of all existing underground services in the work area prior to commencement of work. All underground service locations shall be clearly marked and protected during the course of construction. Damages to existing services resulting from the Contractor's operations shall be repaired at the Contractor's expense.

~~Excavation for the MSE wall shall be carried out in conformance with Section 1 “Excavation” of the Specifications for Bridge Construction and these specifications.~~ Excavation shall be completed to the design grades shown on the design drawings, shop drawings, and as determined by the Consultant. The Contractor shall proof roll the foundation subgrade after excavation to identify any soft spots. Soft material, as determined by the Consultant, shall be removed and replaced with compacted granular crushed aggregate material to the satisfaction of the Consultant. Any temporary excavation support required shall be the full responsibility of the Contractor and no separate or additional payment will be made.

~~25.5.4 The Contractor shall not commence further construction of the MSE wall until the excavation, ground improvements, and foundation base preparation have been completed and the sealed and signed formalized documentation has been submitted to the Consultant and his geotechnical engineer for review and acceptance. The Consultant’s review and acceptance of the foundation base preparation shall not be considered as relieving the Contractor of the responsibility for completing the Work in accordance with these specifications.~~

#### ~~25.4.3~~ 25.5.4 Concrete Leveling Pads

##### ~~Concrete Leveling Pads~~

Construction of concrete leveling pads shall conform to the requirements of Section 4 ~~“Cast-In-Place Concrete” of the Specifications for Bridge Construction.~~ Concrete leveling pad elevations shall be set by instrument. ~~Tolerance~~ The deviation from the detailed design profile shall not exceed 3 mm over a 3 m length and panels shall be centered on the leveling pad.

#### ~~25.5.5 Backfill~~

~~Backfill shall include the supply, placing and compaction required for construction of the MSE wall systems and be in accordance with Section 2 “Backfill” of the Specifications for Bridge Construction and these specifications. Backfill placement shall closely follow. After erection of each course the first row of panels. Backfill shall be placed in such a manner as to avoid any damage or disturbances of the wall materials or misalignment of the precast concrete fascia panels. Any MSE wall components that are damaged during backfill placement shall be removed and replaced at the Contractor’s expense. Any misalignment or distortion of the precast concrete fascia panels due to placement of backfill shall be corrected by the Contractor at his expense, any openings between leveling pad steps shall be formed and filled with Class C cast-in-place concrete in a manner acceptable to the Consultant.~~

~~Where geosynthetic reinforcement is used, overlap of geosynthetic reinforcement can occur in walls with curves or acute angle corners. For any wall layout where overlap of geosynthetic reinforcement occurs, a minimum 75 mm of compacted backfill shall be placed between geosynthetic reinforcement layers.~~

~~Concrete leveling pads that are not constructed to the elevations shown on the Drawings and/or within the specified tolerances shall be removed and replaced. After removal of the concrete leveling pads, the foundation base shall be prepared, inspected, reviewed and accepted in accordance with Subsection 25.5.2, Conformance Criteria before proceeding with recasting.~~



### 25.5.5 Backfilling

Backfill shall be placed and compacted in accordance with Section 2, Backfill, the MSE wall supplier's recommendations and these specifications. In the case of conflicting requirements the most stringent requirements shall govern.

All backfill shall be placed in lifts not exceeding 150 mm in thickness of loose material.

The Contractor shall not place backfill on frozen substrate.

Backfill shall be placed such that soil reinforcement is fully supported for the entire length of the soil reinforcement. At precast concrete panel fascia panel connections small, localized pockets may be present to facilitate connection hardware installation. The extent of the small, localized pockets shall be in accordance with the supplier's recommendations and acceptable to the Consultant.

No equipment shall be allowed to run directly on soil reinforcement. Backfill compaction shall be performed such that equipment moves parallel to the ~~wall~~ precast concrete fascia panels and away from the precast concrete fascia panels toward the end of the soil reinforcement. Only hand operated power tampers and vibrators shall be used for compaction within 1000 mm of the ~~wall~~ precast concrete fascia panels. At the completion of each day's work the Contractor shall slope the last level of backfill away from the ~~wall~~ precast concrete fascia panels, ~~at the completion of each day's work~~ to direct potential ~~surface~~ run-off away from the ~~wall face~~. ~~In addition, the Contractor shall not permit any surface run-off from adjacent areas to enter the wall construction site~~ precast concrete fascia panels.

Backfill placement and compaction testings shall closely follow erection of the reinforced ~~each course of precast concrete fascia panels~~. Backfill shall be ~~done~~ placed in such a manner as to avoid any damage or disturbances of the MSE wall components or misalignment of the precast concrete fascia panels. All MSE wall components that are damaged during backfill placement shall be removed and replaced at the Contractor's expense. Any misalignment or distortion of the precast concrete fascia panels due to placement of backfill shall be corrected by the Contractor at his expense before continuing with the Work.

For any wall layout where overlap of geosynthetic reinforcement occurs, a minimum frequency of one test per 75 mm of compacted backfill shall be placed between geosynthetic reinforcement layers.

A control strip density shall be established on the first lift and every 900 vertical millimetres of backfill placed thereafter (once every 6 lifts) for every 45 metres of wall or part thereof with ~~and not~~ less than ~~one test~~ once per day. ~~Backfill compaction~~ The control strip density shall be measured in accordance with Alberta Transportation Test Method ATT-58A, "DENSITY TEST, Density Test Control Strip Method". ~~The density of compacted~~. All backfill lifts shall be compacted to a minimum of 98% of the control strip density and shall be measured in accordance with Alberta Transportation Test Method ATT-11, Density Test In-Place Nuclear Method. Compaction testing results shall be provided to the Consultant at the end of each day or as requested by the Consultant.

Sieve analysis shall be completed on backfill being placed at the beginning and end of each day for each zone of backfill containing soil reinforcing. Results shall be submitted to the Consultant at the end of each day or as requested by the Consultant. The Contractor shall also complete ~~the following~~ sampling and testing of the backfill during construction in accordance with Table 25-6, Backfill Sampling and Testing Requirements during Construction, to demonstrate continued compliance:.

**SAMPLING AND TESTING OF BACKFILL PROPERTIES Table 25-6: Backfill Sampling and Testing Requirements during Construction**

Range of Resistivity (ohm-cm)	Sample Interval for Resistivity Testing (m <sup>3</sup> )	Sample Interval for PH, Chlorides, Sulphates, Organic Testing (m <sup>3</sup> )
>5000	3000	1500
<5000 <u>and ≥3000</u>	1500	750

~~Test results shall be submitted to the Consultant within 3 days of completion.~~ If any test result does not meet specification requirements, the Contractor shall stop backfilling operations immediately and resample and test the backfill. Additional testing of material already placed may be required and will be determined by the Consultant. Test results shall be submitted to the Consultant within 3 days of completion. Backfilling operations shall not ~~recommence~~continue until all ~~additional sampling and~~ testing is completed and any non-compliant backfill removed and replaced. All costs associated with sampling and testing, including removal and replacement of non-compliant backfill ~~will,~~ and the replacement of any damaged MSE wall components shall be at the Contractor's expense.

~~25.4.4~~25.5.6 ~~25.5.6~~ Precast Concrete Fascia Panel Installation ~~Tolerances~~

The height of shims at any location shall not exceed the specified precast concrete fascia panel installation tolerances of.

Any precast concrete fascia panel damaged during installation, including cracks, spalls or broken corners, shall be rejected, and new precast concrete fascia panels shall be provided.

- ~~1. Flatness of wall surfaces measured in any direction shall not exceed 25 mm under a 3-m straight edge.~~
- ~~2. Offset of adjacent panel edges at joints shall not exceed 10 mm.~~
- ~~3. Overall vertical alignment of the completed wall shall not exceed 4 mm/m of the total wall height.~~
- ~~4. Joint width shall be between 10 mm and 30 mm.~~

~~Should any panels be out of tolerance, the backfill shall be removed and the panels reset to the specified tolerance.~~

All precast concrete fascia panel lifting hook pockets shall be patched with an approved type NH or HEH concrete patching material. The approved concrete patching material shall be placed in accordance with the manufacturer's recommendations.

Precast concrete fascia panels shall be installed to the following tolerances:

- The out-of-flatness of wall surfaces measured in any direction shall not exceed 25.5.7  
Cast-in-Place Concrete Wall Copings mm under a 3 m straight edge;
- The offset of adjacent panel edges at joints shall not exceed 10 mm;
- The overall out-of-vertical alignment of the completed wall shall not exceed 4 mm/m of  
the total MSE wall height; and
- The joint gap width shall be between 10 mm and 30 mm.

For any precast concrete fascia panel that does not meet the specified installation tolerance, the backfill shall be removed and the precast concrete fascia panel reset to the specified tolerance before continuing construction.

#### 25.4.5~~25.4.5~~ 25.5.7 Cast-in-Place Concrete Wall Coping Caps

Construction of cast-in-place concrete wall ~~copings~~copings caps and surface finishes shall conform to the requirements of Section 4 “Cast-In-Place Concrete”~~of the Specifications for Bridge Construction~~ and Section 5, Reinforcing Steel. Cast-in-place concrete wall coping cap elevations shall be set by instrument. ~~Tolerance from design profile shall be 3 mm over a 3 m length.~~

Galvanized anchor bolt assemblies for safety railings shall be cast into the concrete.

Cast-in-place concrete wall coping cap sections located at corners shall be isolated from contact with other concrete components with 12 mm thick closed cell foam.

#### 25.4.6~~25.4.6~~ 25.5.8 ~~25.5.8~~ Impermeable Geomembrane

Seams of impermeable geomembranes shall be placed parallel to the MSE wall and lapped in the direction of positive drainage to produce a shingling effect. ~~Seams~~The membrane shall be ~~welded~~installed in accordance with the manufacturer's recommendations and in weather conditions acceptable to the Consultant.

#### ~~25.5.9~~ Barrier/Railings

#### 25.5.9 Safety Railings

All steel components of ~~traffic barriers, pedestrian/cyclist railings, and~~ safety railings shall be ~~constructed~~erected in accordance with Section 12 “Bridgerail”~~of the Specifications for Bridge Construction~~.

~~25.4.7~~25.5.10 ~~25.5.10~~ Material Storage

The Contractor's lay-down area shall be graded level to ensure precast concrete fascia panels are safely and uniformly supported on timber bearing blocks with plastic separators. Precast concrete fascia panels shall be stacked on timber planks or pallets and separated by timber blocks with dimpled plastic separators designed by ~~the precast supplier's engineer.~~ Soil reinforcement and connectors shall be stored above ground. All materials shall be covered and protected from rain, snow, dirt, ultraviolet light, and damage. a Professional Engineer.

Precast concrete fascia panels shall be stored such that the uniform color of the panels is maintained and protected from staining or discoloration. Panels with stained, discoloured, or damaged front faces shall not be incorporated into the wall.

~~25.6~~—All materials shall be stored above ground, covered and protected from rain, snow, dirt, and ultraviolet light. Any damage identified by the Consultant shall be repaired to the full satisfaction of the Consultant.

~~25.5.11~~ Drainage Management during Construction

The Contractor shall construct, maintain and modify temporary drainage features to prevent adverse amounts of surface run-off from entering the MSE wall construction area. Any erosion or other adverse effects, resulting from inadequate drainage management shall be immediately addressed by the Contractor and repaired to the full satisfaction of the Consultant.

~~25.5~~25.6 Measurement and Payment

Measurement for payment of mechanically stabilized earth walls will be ~~based on~~by the square metre of wall acceptably installed precast concrete fascia panels in place, measured to the nearest 0.1 m<sup>2</sup>.

Payment will be made at the unit price bid for "Mechanically Stabilized Earth ~~Wall~~Walls", and will be full compensation for ~~the design, construction, and submission of as-built shop drawings, design notes and construction records.~~ Payment will also include, but not be limited to, excavation, backfill and compaction below the MSE walls where required; all excavation, concrete leveling pad construction, backfill material and compaction within and beyond the MSE wall zone necessary for construction of the MSE wall; the; supply and; fabrication; delivery; installation of precast concrete fascia panels complete with epoxy coated reinforcing steel; cast-in-place concrete wall coping complete with epoxy coated reinforcing steel; soil reinforcement; testing and inspection wires; sealer; drains; traffic barriers and anchor blocks; the supply and installation of galvanized steel safety railing including anchor bolts and swales at the top of the MSE wall construction; and all labour, material materials, equipment, tools, and incidentals necessary to complete the Work as shown on the Drawings, shop drawings, and to the satisfaction of the Consultant.

90% of the unit price bid will be paid once the MSE precast concrete panels have been acceptably installed and backfilled. The remaining 10% of the unit price bid will be made once the cast-in-place concrete wall coping caps have been placed and received surface finishes, handrails have been installed, drainage systems are functional, and the specified construction documentation has been submitted, reviewed and accepted by the Consultant.



# STANDARD SPECIFICATIONS FOR BRIDGE CONSTRUCTION

## SECTION 26 RCP AND PBC STRUCTURES

### TABLE OF CONTENTS

<b>26.1</b>	<b>General</b>	<b>26-1</b>
<b>26.2</b>	<b>Supply and Manufacture</b>	<b>26-1</b>
26.2.1	Reinforced Concrete Pipe	26-1
26.2.2	Precast Box Culvert	26-1
26.2.3	Qualification	26-2
26.2.4	Engineering Data	26-3
26.2.4.1	Shop Drawings	26-3
26.2.4.2	Design Notes and Independent Check Notes	26-4
26.2.4.3	Mill Test Reports and Product Data Sheets	26-4
26.2.4.4	Concrete Mix Design Submission Requirements	26-5
26.2.5	Pre-fabrication Meeting	26-5
26.2.6	Materials	26-5
26.2.6.1	Hydraulic Cement	26-5
26.2.6.2	Reinforcing Steel	26-5
26.2.6.3	Rubber Gaskets and Flexible Joint Sealants	26-5
26.2.7	Testing and Inspection	26-6
26.2.7.1	Access	26-6
26.2.7.2	Responsibility	26-6
26.2.7.3	Witness Points	26-6
26.2.7.4	Testing by the Contractor	26-6
26.2.8	Section Identification Markings	26-7
26.2.8.1	Reinforced Concrete Pipe	26-7
26.2.8.2	Precast Box Culvert	26-7
26.2.9	Standard Identification Plaques	26-9
26.2.10	Defects	26-9
26.2.10.1	Honeycomb, Cavities, Chips, Spalls, and Casting Defects	26-10
26.2.10.2	Cracks	26-10
26.2.11	Handling and Storage	26-11
26.2.12	Notification to Ship	26-12
26.2.13	Fabrication Outside of Canada	26-20
<b>26.3</b>	<b>Construction</b>	<b>26-21</b>
26.3.1	General	26-21
26.3.2	Care of Water	26-21
26.3.3	Excavation	26-22
26.3.4	Erection Procedure	26-22
26.3.5	Installation	26-23
26.3.5.1	General	26-23
26.3.5.2	Reinforced Concrete Pipe	26-23
26.3.5.3	Precast Box Culvert	26-24
26.3.6	Backfilling	26-24
<b>26.4</b>	<b>Substrate Holders</b>	<b>26-25</b>

<b>26.5</b>	<b>Heavy Rock Riprap</b> .....	<b>26-26</b>
<b>26.6</b>	<b>Post-Installation Inspection</b> .....	<b>26-26</b>
26.6.1	Reinforced Concrete Pipe .....	26-26
26.6.2	Precast Box Culvert .....	26-26
<b>26.7</b>	<b>Measurement and Payment</b> .....	<b>26-27</b>



## 26.1 General

This specification ~~describes~~ is for the supply, manufacture, delivery, and installation of Reinforced Concrete ~~Pipes~~ Pipe (RCP) and Precast Box Culvert (PBC) structures.

~~Abbreviations for the various types of pipe and box culvert are as follows:~~

~~RCP—Reinforced Concrete Pipe~~

~~PBC—The Work shall be carried out as shown on the Drawings and in accordance with the following specifications. The requirements of this specification shall govern over all referenced standards in the case of conflicting requirements.~~

### ~~26.1.1—Precast Box Culvert~~

## 26.2 ~~26.2—Supply and Manufacture~~

### ~~26.2.1—Standards~~

#### ~~26.2.1 26.2.1.1—Reinforced Concrete Pipe~~ Reinforced Concrete Pipe

~~The supply and manufacture of all~~ Indirect designed ~~RCP~~ Reinforced Concrete Pipe including any maintenance holes (manholes), and flared end pipe sections shall be supplied and manufactured in accordance with ~~the current edition of~~ CSA A257 or ASTM ~~C 76~~. ~~For pipe sizes of 1050 mm or larger direct design pipe~~ C76M and this specification.

Direct designed RCP structures shall be supplied and manufactured in accordance with ~~the current edition of~~ ASTM 1417M “Standard Specification for Manufacture of Reinforced Concrete Sewer, Storm Drain, and Culvert Pipe for Direct Design (Metric)” ~~may be used by the engineer, following the design procedure in the American Society for Civil Engineers (ASCE) “Standard Practice for Direct Design of Buried Precast Concrete Pipe using Standard Installations (SIDD) No.15”.~~ C1417M and this specification.

When specified on the Drawings, maintenance access holes (manholes) shall be supplied and manufactured in accordance with ASTM C478M.

### 26.2.2—Precast Box Culvert

#### ~~26.2.1.2—Precast Box Culvert~~

~~The supply and manufacture of all~~ Precast Box Culverts shall be in accordance with the current edition of ASTM 1433M “Standard Specification for Precast Reinforced Concrete monolithic Box Sections for Culverts, Storm Drains, and Sewers (Metric)” ~~following the design procedure in the American Society for Civil Engineers (ASCE) “Standard Practice for Direct Design of Buried Precast Concrete Box Sections”.~~

#### ~~26.2.2—Engineering Data~~

~~26.2.2.1 Shop Drawings and Design Reports~~~~26.2.2~~ ~~26.1.1~~ (a) ~~PBC~~ Reinforced Concrete Pipe

~~Shop drawings and design reports shall be provided to the Consultant illustrating that the Reinforced Concrete Pipe has been designed by the direct design methods in accordance with ASCE SIDD No.15. Design factors outlined in the CAN/CSA S6 Canadian Highway Bridge Design Code (CHBDC) shall govern over the ASCE and the ASTM documents C1433M and this specification.~~

~~Shop drawings and design reports submitted to the Consultant shall include the Alberta Transportation bridge file number and project name.~~

~~26.2.3~~ ~~26.1.1~~ (b) ~~Precast Box Culvert~~

~~Shop drawings and design reports shall be provided to the Consultant illustrating that the Reinforced Concrete Box has been designed by direct design methods in accordance with ASCE 28. Design factors contained in the CAN/CSA S6 Canadian Highway Bridge Design Code (CHBDC) shall govern over the ASCE and the ASTM documents.~~

~~Shop drawings and design reports submitted to the Consultant shall include the Alberta Transportation bridge file number and project name.~~

~~26.2.3 Materials~~~~26.2.3.1 Cement~~

~~All reinforced concrete pipes and precast box culverts shall be manufactured from sulphate resistant Type HS or HSb cement in accordance with CSA A3001.~~

~~26.2.3.2 Reinforcing Steel~~

~~Reinforcing steel shall conform to the Specifications for Bridge Construction, Section 5—Reinforcing Steel.~~

~~26.2.3.3 Gaskets~~

~~All gaskets supplied for reinforced concrete pipe projects shall meet the requirements of CSA 257.3.~~

~~The precast box culvert sections shall be joined with preformed flexible joint sealants in accordance with ASTM C990 or rubber gaskets compliant with ASTM C1619.~~

~~26.2.4~~ ~~26.2.3~~ 26.2.4 Qualification

The ~~prime~~ Contractor shall notify the ~~Department and~~ Consultant of any subcontractors in his employ. The Contractor shall remain responsible for the work of the ~~subcontractors~~ subcontractors. All terms of the contract, such as right of access, shall apply to subcontractors.

~~The manufacturer~~ RCP and PBC sections shall operate ~~be supplied and manufactured by a recognized precast concrete fabricator that is certified under the Plant Prequalification Program (PPP) as outlined in the publication, Prequalification Requirements for Precast Concrete Drainage Products.~~

The fabrication of RCP and PBC structures shall be completed in a sufficiently large environmentally controlled permanent building capable of manufacturing plant and be products in a well-organized and continuous operation. The building shall be capable of maintaining a controllable temperature and humidity to meet fabrication requirements and prevent material contamination and/or deterioration.

26.2.4 Engineering Data

A minimum of two weeks prior to the commencement of fabrication, shop drawings, mill test reports, product data sheets, and the concrete mix design shall be submitted to the Consultant for review and acceptance.

26.2.4.1 Shop Drawings

Shop drawings shall be submitted to the Consultant for review and acceptance a minimum of 4 weeks in advance of the commencement of fabrication. Review comments provided by the Consultant and/or the Department shall be incorporated into the shop drawings and resubmitted to the Consultant for review and acceptance prior to the commencement of fabrication.

Shop drawings shall be electronic unlocked PDF format. Each shop drawing shall include the Department's shop drawing identification block and have a sufficient blank space for the Consultant's review stamp. The Department's shop drawing identification block will be provided to the Contractor upon request.

The shop drawings will be reviewed by the Consultant solely to ascertain general conformance with codes and specifications. The Consultant's review and acceptance shall not be considered as relieving the Contractor of the responsibility for completing the Work in accordance with the Contract requirements.

The Contractor shall incorporate as-built construction conditions into shop drawings. One paper copy and one electronic copy (PDF format) of as-built shop drawings shall be submitted to the Consultant within 3 weeks of construction completion.

Shop drawings are not required for RCP manufactured in accordance with ASTM C76M or CSA A257.

#### 26.2.4.2 Design Notes and Independent Check Notes

If modifications to the Contract requirements are proposed, the Contractor shall submit design notes, independent check notes, and shop drawings signed and sealed by his design engineer of record and by an independent checker.

The design engineer of record and the independent checker shall be Professional Engineers registered in the Province of Alberta. Design notes and independent check notes shall be submitted to the Consultant for review and acceptance a minimum of 4 weeks in advance of the commencement of fabrication. Review comments provided by the Consultant and/or the Department shall be incorporated into the design notes and independent check notes and shop drawings and resubmitted to the Consultant for review and acceptance prior to the commencement of fabrication. The design engineer of record and independent checker shall submit separate signed and sealed design notes and independent check notes. The design and check notes shall be presented in a legible and logical format, clearly identify material properties, and sufficiently detailed to allow a technical review of design concepts and assumptions used.

The independent checker may be employed by the same company as the design engineer of record. The independent check must be completed fully certified by the Ontario Concrete Pipe Association (OCPA) Prequalification Program independent of the design engineer of record, including a complete re-analysis of all aspects of the design including calculations and engineering, preferably by a methodology or computer program other than that used by the design engineer of record. The design engineer of record and independent checker shall ensure that the shop drawings are complete and accurately convey the design criteria and assumptions used in their designs.

The design notes, independent check notes, and shop drawings will be reviewed by the Consultant solely to ascertain general conformance with codes and specifications. The Consultant's review and acceptance shall not be considered as relieving the Contractor of the responsibility for completing the Work in accordance with the Contract requirements.

The Contractor shall incorporate and submit as-built design notes, check notes, and shop drawings for records at the completion of construction. One paper copy and one electronic copy (PDF format) of as constructed shop drawings, design and check notes, and supplier inspection construction records shall be submitted to the Consultant within 3 weeks of construction completion.

#### 26.2.4.3 Mill Test Reports and Product Data Sheets

Mill test reports and product data sheets shall be provided for all materials used in the manufacture of RCP and PBC structures in English.

Mill test reports shall be submitted to the Consultant for review and acceptance 3 weeks prior to commencement of fabrication.

Where mill test reports originate from a mill outside Canada or the United States of America, the Contractor shall have mill test reports verified by a certified laboratory in Canada by testing the material to the specified material standards, including boron content. The testing laboratory shall be certified to ISO/IEC 17025 by an organization accredited by the Standards Council of Canada for the tests required. Samples for testing shall be collected by personnel employed by the certified laboratory. A verification letter shall be provided by the certified laboratory that includes at a minimum, the applicable mill test reports, testing standards, date of verification testing, and declaration of material compliance with Contract requirements. The verification letter shall be signed by an authorized officer of the certified laboratory.

#### 26.2.4.4 Concrete Mix Design Submission Requirements

Concrete mix design submission requirements shall be provided in accordance with Subsection 4.4.4, Concrete Mix Design Submission Requirements.

#### 26.2.5 Pre-fabrication Meeting

A pre-fabrication meeting is required prior to the commencement of fabrication of PBC and direct designed RCP structures. A pre-fabrication meeting is not required for indirect designed RCP structures. The pre-fabrication meeting shall be held at the fabrication facility and the Contractor shall ensure that the fabrication superintendent, fabrication manager, and supervisors directly involved in the Work are in attendance. The meeting shall not occur until shop drawings, design notes and independent check notes (as applicable), and welding procedures have been reviewed and accepted by the Consultant. The date of the pre-fabrication meeting shall be reviewed and accepted by the Consultant and the Department and proposed a minimum of 2 weeks prior to the anticipated date.

#### 26.2.6 Materials

##### 26.2.6.1 Hydraulic Cement

Hydraulic cement used in the manufacture of RCP and PBC shall be Type HS or HSb and conform to the requirements of CSA A3001.

##### 26.2.6.2 Reinforcing Steel

Reinforcing steel for RCP structures shall conform to the requirements of ASTM C76M or ASTM C1417M.

Reinforcing steel for PBC structures shall conform to the requirements of ASTM C1433M and Section 5, Reinforcing Steel.

The boron content of reinforcing steel shall not exceed 0.0008%.

##### 26.2.6.3 Rubber Gaskets and Flexible Joint Sealants

Rubber gaskets for RCP structures shall conform to the requirements of CSA A257.3.

Flexible joint sealants for PBC structures shall conform to the requirements of ASTM C990.

Rubber gaskets for PBC structures shall conform to the requirements of ASTM C1619.

### 26.2.7 Testing and Inspection

#### 26.2.7.1 Access

The Contractor shall provide full facilities for the inspection of Work. The Consultant shall have full access to all parts of the Work at all times. When required by the Consultant, the Contractor shall provide needed manpower for assistance in checking layout and performing inspection duties.

#### 26.2.7.2 Responsibility

It is the Contractor's responsibility to ensure that the Work is completed in accordance with the Contract requirements. Any inspection and/or testing completed by the Consultant, review and acceptance by the Consultant, shall not be considered as relieving the Contractor of the responsibility for completing the Work in accordance with the Contract.

#### 26.2.7.3 Witness Points

Inspection stations shall be set up at specific points during the course of fabrication for the Consultant to complete inspection and/or testing. At each witness point the Work shall be checked by the Contractor, reviewed and accepted by the Consultant, and all deficiencies corrected to the full satisfaction of the Consultant prior to the next sequence of fabrication.

Witness points for RCP and PBS Structures shall be:

- Form dimensions and set-up;
- Placement of reinforcement;
- Placement of voids and hardware;
- Concrete mixture and placement;
- Form stripping;
- Clean-up and repair;
- Curing;
- Storage of units.

#### 26.2.7.4 Testing by the Contractor

Sampling, casting, curing and testing concrete specimens shall be completed by the Contractor to demonstrate specification compliance. The Contractor's testing and inspection records shall be open for examination by the Consultant upon request.

Testing, inspection and related costs incurred by the Consultant resulting from defective work or Contractor proposed details not specified on the Drawings shall be paid for by the Contractor.

26.2.8 Section Identification Markings~~26.2.4.1~~ 26.2.8.1 Reinforced Concrete Pipe~~26.2.5~~ Identification~~26.2.5.1~~ Pipe

~~All pipes supplied~~ classified and indirect designed RCP sections shall be marked in accordance with ASTM 1417M standards with waterproof paint or have markings cast into the sections as follows:

- The Pipe classification and manufacturing standard;
- Nominal inside diameter;
- Date of manufacture;
- Name or logo of manufacturer;
- Plant identification; and
- Installation orientation markings, if required.

All direct designed RCP sections shall be marked with waterproof paint or have markings cast into the sections as follows:

- ~~Pipe designation shall be indicated as follows:~~
  - ~~Di \_\_\_\_\_, \_\_\_\_\_ T \_\_\_\_\_, \_\_\_\_\_ H \_\_\_\_\_ - \_\_\_\_\_ where,~~
  - ~~Di = designated pipe nominal inside diameter, mm;~~
  - ~~T = installation type;~~
  - ~~H = (minimum)-(maximum) fill height, m;~~
- The Manufacturing standard;
- Date of manufacture;
- ~~The manufacture's~~ Name or trademark/logo of manufacturer;
- ~~The~~ Plant identification;
- Pipe identification number; and
- Installation orientation markings, if required.

When RCP sections are marked by casting identification into concrete, the minimum specified cover shall be maintained.

- ~~—~~ Precast Box Culvert ~~For pipe with elliptical reinforcement or otherwise requiring special placement, appropriate marking to indicate the correct installed orientation.~~
- ~~—~~ Plant Prequalification Symbol

~~26.2.5.2~~ Box Sections

~~All boxes supplied shall be marked in accordance with ASTM 1433M standards:~~

26.2.8.2 The

All PBC sections shall be marked with waterproof paint or have markings cast into the sections as follows:

- ~~Box designation shall be indicated as follows:~~
  - ~~S \_\_\_\_\_, \_\_\_\_\_ R \_\_\_\_\_, \_\_\_\_\_ H \_\_\_\_\_ - \_\_\_\_\_ where,~~
  - ~~S = designated box section span, mm,~~
  - ~~R = designated section rise, mm,~~
  - ~~H = (minimum)-(maximum) fill height, m~~
- The Manufacturing standard;
- Date of manufacture;
- The manufacturer's Name or trademark/logo of manufacturer;
- The Plant identification (Box Id);
- ~~One end of each box section designed to be installed with the top slab up shall be legibly marked during the process of manufacturing or immediately thereafter on the inside and outside of the top slab, or shall have the top identified by the location of one or more lift holes or devices~~
- ~~Plant Prequalification Symbol~~

26.2.6 Shop Inspection

~~All terms of the contract shall apply to the subcontractor. The Department and Consultant shall have rights to access the subcontractor's plant to perform quality assurance inspection, as deemed necessary.~~



#### 26.2.6.1 — Notification

~~The Contractor shall notify the Consultant a minimum of 72 hours prior to the start of manufacture to facilitate inspection of the materials at the plant. Material that has not been inspected and accepted by the Consultant at the manufacturer's plant will not be passed for payment until such material has been inspected and accepted. The Contractor will be responsible for all expenses incurred for the material to be inspected by the Consultant at the site.~~

#### 26.2.6.2 — Inspection, Sampling and Testing

~~All materials shall be subject to inspection, sampling and quality assurance testing by the Consultant. The Contractor shall provide safe, convenient access acceptable to the Consultant for inspection and sampling of the materials, and shall cooperate in the inspection and sampling process when requested to do so. Any material found unacceptable by the Consultant shall be replaced or repaired with acceptable material by the Contractor at the Contractor's expense.~~

~~All costs associated with the re-inspection required by the Consultant due to faulty work shall be paid for by the Contractor.~~

#### 26.2.6.3 — Crack Identification/Repairs

~~Cracks in RCP or PBC identified either at the manufacturer's plant or at the project site will require action as follows:~~

- ~~• Cracks equal to or less than 0.2 mm, in width are considered minor and shall be documented on the inspection report.~~
- ~~• Box identification number; and~~
- ~~• Installation orientation markings showing the top of slab up on both inside and outside faces.~~

~~When PBC sections are marked by casting identification into concrete, the minimum specified cover shall be maintained.~~

#### 26.2.9 Standard Identification Plaques

~~Standard identification plaques shall be supplied and installed in accordance with Section 13, Miscellaneous Iron and Standard Drawing S-1847, Standard Identification Plaques and Benchmark Tablet.~~

#### 26.2.10 Defects

~~Defects in RCP or PBC identified either at the fabricator's plant or at the construction site shall be repaired by the Contractor at his expense to the satisfaction of the Consultant.~~

Honeycomb, cavities, spalls, chips, cracking and other defects shall be immediately reported to the Consultant. Repair procedures shall be developed by the Contractor and submitted for review and acceptance by the Department and Consultant prior to the commencement of the repair. Repair procedures may vary for the RCP and PBC structures and the Contractor shall consider the physical dimensions and properties of the element being repaired. The Consultant shall be notified a minimum of 24 hours before the commencement of any repair.

In cold weather conditions this work shall be carried out in accordance with Subsection 4.21, Concreting in Cold Weather.

#### 26.2.10.1 Honeycomb, Cavities, Chips, Spalls, and Casting Defects

As a minimum, the Contractor's repair procedure for repairing defects less than 30 mm in depth shall include:

- Roughening the repair area to remove all loose material and laitance;
- Filling the repair area with an approved concrete patching material listed on the Department's Product list in the Overhead/Vertical (OH-V) category;
- Placing the repair material in accordance with the manufacturer's published product data sheet;
- Wet curing the repair material for a minimum of 72 hours; and
- Finishing the repair area to achieve a surface uniform in color and texture to the surrounding concrete.

As a minimum, the Contractor's repair procedure for repairing defects greater than 30 mm in depth shall include:

- Saw cutting the repair extents in neat perpendicular lines;
- Removing the concrete to a depth beyond the reinforcement by a minimum of 1.5 times the maximum concrete aggregate used in the concrete mix;
- Roughening the repair area to remove all loose material and laitance;
- Repairing and cleaning reinforcement to its original condition;
- Saturating the repair area with water for a period of 3 hours prior to concrete placement;
- Cleaning and drying the repair area with oil-free compressed air;
- Placing and curing the replacement concrete in accordance with the requirements of this specification; and
- Finishing the repair area to achieve a surface uniform in color and texture to the surrounding concrete.

#### 26.2.10.2 Cracks

All cracks will be measured, mapped, and documented in the fabrication inspection report by the Consultant. Cracks shall be monitored, repaired or sections replaced as follows:

- Sections with cracks 0.3 mm in width or greater shall be replaced with new sections;

- Cracks greater than 0.2 mm and less 0.3 mm in width shall be assessed by the ~~manufacturer~~Contractor and a repair or replacement strategy developed. The repair or replacement strategy shall be submitted to the Department and Consultant for review and acceptance prior to the commencement of the repair or replacement work. ~~The Consultant shall be present for all repair work undertaken by the manufacturer or Contractor.; or~~
- ~~Sections with cracks 0.3 mm in width or greater shall be rejected.~~

#### ~~26.2.7 Stockpiles~~

- Cracks equal to or less than 0.2 mm in width shall be monitored throughout construction and if crack width growth occurs they shall be repaired or sections replaced in accordance with the requirements of these specifications.

#### 26.2.11 Handling and Storage

All ~~material~~materials shall be ~~unloaded and stockpiled~~stored in a neat and orderly manner, to facilitate testing and inspection ~~and inventory, and in such a manner as to ensure suitability for the work.~~ ~~Stockpiled materials, accepted on delivery as to quantity,~~

Rubber gaskets and sealants shall ~~meet~~be stored in accordance with the specified requirements ~~at the time they are to be used in the work.~~ ~~Reinforced concrete pipe should be stockpiled at ground height rather than stacking two or more pipes in height~~manufacturer's recommendations.

#### ~~26.2.8 Handling of Material~~

All RCP and PBC ~~material~~sections shall be handled carefully and in such a manner as to prevent cracking, gouging ~~or~~, chipping, or any other damage to the concrete surfaces. ~~All rubber gaskets shall~~

RCP and PBC sections shall be stored at ground height with supports acceptable to the Consultant and shall not be kept warm at room temperature prior to installation during winter months. ~~Culvert material~~stacked vertically.

RCP and PBC sections designated by the Consultant as unacceptable, due to failure to meet the specified requirements, shall be immediately repaired in accordance with Subsection 26.2.10, Defects, or replaced by the Contractor at his expense.

~~26.3 Installation~~

~~The installation of RCP and PBC shall be carried out in a professional manner meeting all the requirements of the preparation of bedding and haunch gravel as specified on the drawings. It is essential that the structure be kept dewatered to the bottom of the excavation until all backfilling is complete.~~

~~Installation of RCP and PBC shall follow both ASTM C1479M and CAN/CSA S6 Canadian Highway Bridge Design Code respectively.~~

~~26.2.12 Notification to Ship~~

~~The Contractor shall submit documentation of lifting procedures for the Consultant's review, two weeks prior to installation of RCP or PBC.~~

~~26.3.1 notify Excavation~~

~~Excavation shall be done to the lines and grades shown on the drawings, or as determined by the Consultant, 72 hours prior to shipment to facilitate inspection and in accordance with the appropriate sections acceptance of Section 1 "Excavation" of the Specifications for Bridge the RCP Construction.~~

26.3.2—Bedding/Backfill

26.3.2.1—Reinforced Concrete Pipe

Excavation and backfill PBC structures. RCP and PBC structures shall conform to Figure 3 “Standard Trench Installation” from ASTM C1479M and Section 7.8 from CAN/CSA S6 Canadian Highway Bridge Design Code.

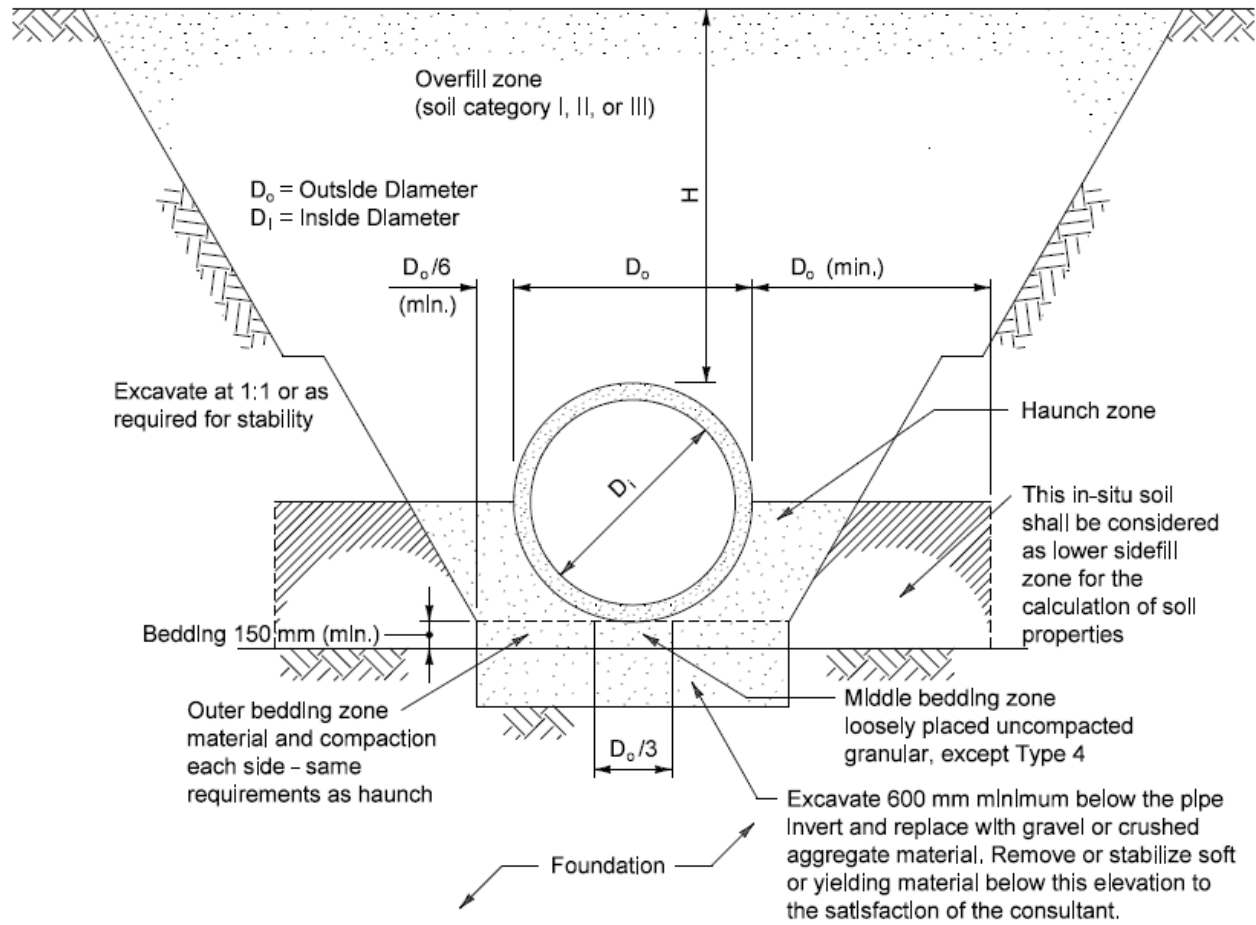


Figure 3 Standard Trench Installations

~~Bedding and haunch criteria for reinforced concrete pipe shall follow one of the following bedding types based on the Consultant's design: \_\_\_\_\_~~

<del>Installation Type</del>	<del>Bedding Thickness</del>	<del>Haunch and outer bedding</del>	<del>Lower side</del>
<del>Type 1</del>	<del><math>D_o/24</math> minimum; Not less than 75mm If rock foundation, use <math>D_o/12</math> minimum; Not less than 150 mm</del>	<del>95% Category I</del>	<del>90% Category I 95% Category II or 100% Category III</del>
<del>Type 2</del>	<del><math>D_o/24</math> minimum: Not less than 75mm If rock foundation, use <math>D_o/12</math> minimum; Not less than 150 mm</del>	<del>90% Category I or 95% Category II</del>	<del>85% Category I 90% Category II or 95% Category III</del>
<del>Type 3</del>	<del><math>D_o/24</math> minimum: Not less than 75mm If rock foundation, use <math>D_o/12</math> minimum; Not less than 150 mm</del>	<del>85% Category I 90% Category II or 95% Category III</del>	<del>85% Category I 90% Category II or 95% Category III</del>
<del>Type 4</del>	<del>No bedding required, except if rock foundation, use <math>D_o/12</math> minimum; Not less than 150 mm</del>	<del>No Compaction required, except if Category III, use 85% Category III</del>	<del>No Compaction required, except if Category III, use 85% Category III</del>

~~$D_o$  denotes the outside diameter~~

Categories of soil for haunch and bedding material shall not be defined by the following table as per ASTM 1479M:

Soil	Representative Soil Types		% Compaction	
	USCS	ASSHTO	Standard Proctor	Modified Proctor
	ASTM Practice D-2487	M145		
Category I	<del>Clean, coarse grained soils: SW, SP, GW, GP or any soil beginning with one of these symbols with 12% or less passing a 75 µm sieve</del>	<del>A-1, A-3</del>	<del>100</del>	<del>95</del>
			<del>95</del>	<del>90</del>
			<del>90</del>	<del>85</del>
			<del>85</del>	<del>80</del>
Category II	<del>Coarse grained soils with fines: GM, GC, SM, SC or any soil beginning with one of these symbols, containing more than 12% passing a 75 µm sieve</del>	<del>A-2-4, A-2-5, A-2-6; OR A-4 OR A-6 soils with 30% or more retained on a 75 µm sieve</del>	<del>100</del>	<del>95</del>
			<del>95</del>	<del>90</del>
			<del>90</del>	<del>85</del>
			<del>85</del>	<del>80</del>
Category III	<del>Fine grained soils: CL, ML, (or CL-ML, GL/ML, ML/CL) with less than 30% retained on a 75 µm sieve</del>	<del>A-2-7; or A-4 or A-6 with less than 30% retained on a 75 µm sieve</del>	<del>100</del>	<del>90</del>
			<del>95</del>	<del>85</del>
			<del>90</del>	<del>80</del>
			<del>85</del>	<del>75</del>
Category IV	MH, CH, OL, OH, PT	A-5, A-7	100	90
			95	85
			90	80
but <del>not allowed for haunch and bedding</del>				
Compaction Specifications:				
Standard proctor density <del>— AASHTO T 99, T 310, or Test Methods D 698</del>				
Modified proctor density <del>— AASHTO T 180 or Test Methods D 1557</del>				

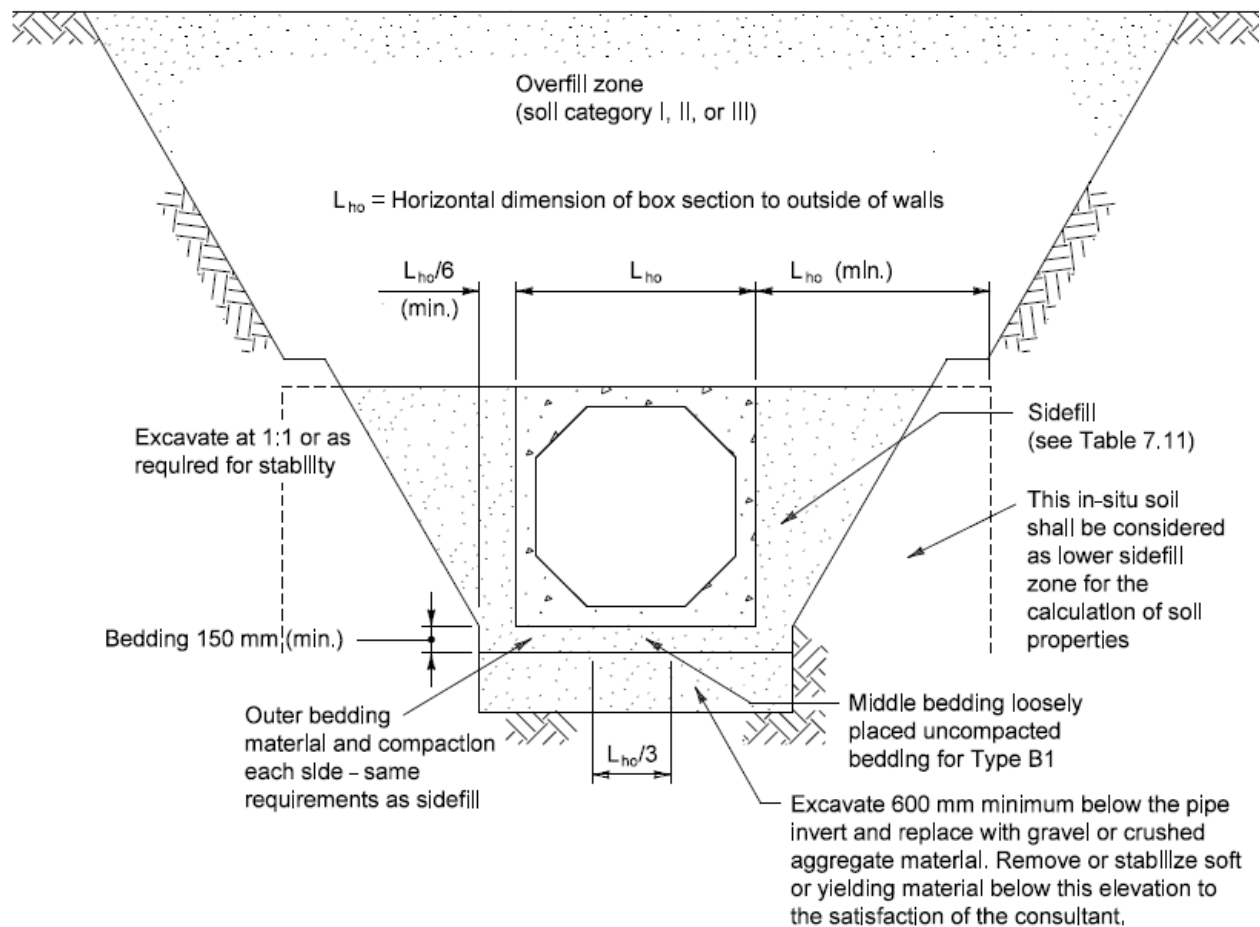
When the bottom of the excavation lies below the pipe invert, the fill material shall be compacted by the Contractor to a minimum of 95% of Standard Proctor Density at optimum moisture content up to the bedding material.

The thickness of the bedding material shall be according to that previously stated and shall be placed in a loose, un-compacted state under the middle third of the pipe. The bedding elevation shall be constructed as per the thickness of the pipe and the Consultant's proposed invert elevation.

Haunch material need only extend to the 'springline' of the pipe. Clean material void of rocks and sharp objects shall be used in the overfill zone from the springline of the pipe to the road surface.

### 26.3.2.2—Precast Box Culvert

Figure 7.11 illustrates the excavation and backfill requirements.





**Figure 7.11**

**Standard Installations for Concrete Box Sections in Trenches**

~~Bedding and haunch criteria for precast box culverts shall conform to one of the following installation types from the CHBDC:~~

~~Table 7.11~~

~~Soils and compaction requirements for standard installation for concrete boxes~~

~~(See Clauses 7.8.3.6.1 and Figures 7.10 and 7.11)~~

<del>Installation type</del>	<del>Soil group</del>	<del>Equivalent minimum Standard Proctor compaction in side fill and outer bedding zones</del>
<del>B1</del>	<del>I</del>	<del>90%</del>
	<del>II</del>	<del>95%</del>
	<del>III</del>	<del>Not permitted</del>
<del>B2</del>	<del>I</del>	<del>80%</del>
	<del>II</del>	<del>85%</del>
	<del>III</del>	<del>95%</del>

~~Soil group categories for bedding material shall be defined by the following table as per CHBDC:~~

<del>Soil group<sup>1</sup></del>	<del>Description</del>	<del>Unified Soil Classification symbols<sup>2</sup></del>
<del>I</del>	<del>Sand and gravel</del>	<del>SW, SP, GW, GP</del>
<del>II</del>	<del>Sandy silt</del>	<del>GM, SM, GC and SC with less than 20% passing #200 sieve</del>
<del>III</del>	<del>Sandy clay</del>	<del>CL, MH, GC and SC with more than 20% passing #200 sieve</del>

~~<sup>1</sup> See Table 7.4~~

~~<sup>2</sup> According to ASTM D-2487~~

~~When the bottom of the excavation lies below the culvert invert, the fill material shall be compacted by the Contractor to a minimum of 95% Standard Proctor Density at optimum moisture content.~~

~~The thickness of the bedding material under the middle 1/3 of the culvert, referenced in the previous table, shall be placed in a loose, un-compacted state. The bedding elevation shall be constructed as per the thickness of the box and at the Consultant's proposed invert elevation.~~

### ~~26.3.3 Installation~~

#### ~~26.3.3.1 Reinforced Concrete Pipe (RCP)~~

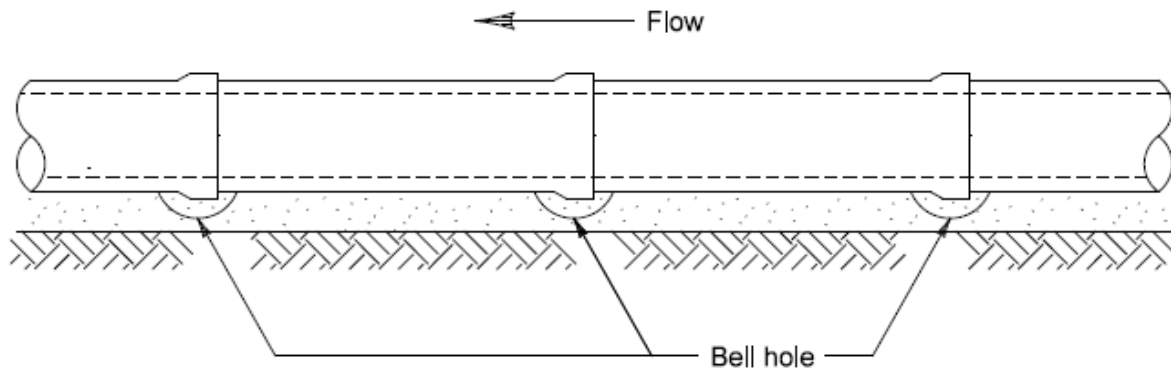
~~Placing and assembly of the pipe may proceed only after excavation, foundation and bottom bedding material~~shipped until they have been inspected~~reviewed~~ and accepted by the Consultant.

~~Assembly of RCP shall include a rubber gasket at each joint conforming to CSA 257.3. The Contractor shall implement proper installation methods and conformance to the manufacturer's recommendations for the rubber gaskets for the particular type of gasket being installed.~~

~~Allowable joint gap spacing between two joined pipe sections shall~~ Review and acceptance of RCP and PBC structures at the fabrication facility by the Consultant will not exceed 13 mm.~~relieve the Contractor of his full responsibility to meet the requirements of these specifications.~~

Contractor shall:

- ~~• Install and join pipe sections in accordance with the manufacturer's recommendations.~~
- ~~• Install the reinforced concrete pipe from the lowest elevation to the highest elevation with the bell end upstream.~~
- ~~• Clean both inside of the bell end and outside of the spigot end prior to installation.~~
- ~~• Keep all rubber gaskets at room temperature and out of direct sunlight. Gaskets shall be free of dirt, oil and grease.~~
- ~~• Where pipe sections are supplied with a protruding bell, excavate at each bell section ensuring uniform support underneath the pipe as per Figure 4 below (ASTM 1479M).~~
- ~~• If the installed pipe section is not on an acceptable grade, the pipe section shall be completely unjoined, the grade corrected, and the pipe then rejoined.~~
- ~~• Use lifting clutches with a 3-legged chain sling (wire or link) for pipe diameter 1050 mm or larger.~~



**Figure 4 Uniform Pipe Support**

~~Under no circumstances shall the Contractor:~~

- ~~• Use an excavator, or any other mechanical device to push, pound, drop, or rock the pipe to achieve the proper grade.~~
- ~~• Drag pipe along the ground to either stockpile or install the pipe.~~
- ~~• Unload pipe by rolling off a truck and dropping onto the ground.~~

#### ~~26.3.3.2 Precast Box Culvert (RCP and PBC)~~

~~Placing and installation of the box may proceed only after the excavation, foundation and bottom bedding material and shape structures that have not been inspected at the fabrication facility will not be paid for until such material has been inspected, reviewed and accepted by the Consultant.~~

~~Installation of the The Contractor shall be responsible for all costs incurred by the Consultant for inspection of the RCP and PBC shall include a rubber gasket and/or coil sealants such as Kent Seal or Con Seal at each joint conforming to CSA 257.3. The Contractor shall implement proper installation methods for the rubber gaskets for the particular type of gasket being installed structures not inspected at the fabrication facility.~~

#### 26.2.13 Fabrication Outside of Canada

All testing and inspection requirements specified in Subsection 26.2.7, Testing and Inspection, shall be completed at the fabrication facility and all costs incurred by the Consultant and their designated testing agencies, and the Department shall be paid for by the Contractor.

All components fabricated outside of Canada shall be shipped to a shop located in Canada that meets the qualification requirements specified in Subsection 26.2.3, Qualification, for re-inspection and testing. The components shall be in a condition that facilitates all testing and inspection requirements. RCP and PBC structures fabricated outside of Canada shall be re-inspected by a Prestressed/Precast Concrete Institute (PCI) certified level II inspector. Testing and inspection shall be completed in accordance Subsection 26.2.7, Testing and Inspection. The PCI certified inspector shall also inspect all components to ensure that they were not damaged during transportation.

In addition three concrete cores shall be taken from each precast concrete unit, at locations determined by the Consultant, and tested by a laboratory certified to CSA A283 to determine that the concrete meets all Contract requirements.

Components shall not be shipped from the Canadian shop until all requirements have been met and the Work has been reviewed and accepted by the Consultant.

The Contractor shall be responsible for all re-inspection and testing costs, including all cost incurred by the Consultant and the Department.

The Contractor shall have no claim against the Department resulting from delays caused by these requirements.

### **26.3 Construction**

#### **26.3.1 General**

Construction of RCP and PBC structures shall be in accordance with Subsection 7.8.15, Construction, of the CSA S6 Canadian Highway Bridge Design Code, and these specifications. RCP structures shall also be constructed in accordance with ASTM C1479M.

The structure shall be kept dewatered to the full extent of the excavation until all backfilling is completed.

Cranes shall be used for the handling and erection of PBC sections and RCP sections that are 2.0 m or larger.

#### **26.3.2 Care of Water**

In addition to ECO plan submission requirements, the Contractor shall also prepare and submit a separate care of water plan signed and sealed by a professional engineer registered in the Province of Alberta to the Consultant for review and acceptance a minimum of 2 weeks prior to the preconstruction meeting. The care of water plan shall outline the means and methods that will be used to control and manage water and/or ice at all times during the Work in accordance with all applicable environmental regulations.

The care of water plan will be reviewed by the Consultant solely to ascertain general conformance with environmental regulations, specifications and any applicable Special Provisions of the Contract. The Consultant's review and acceptance shall not be considered as relieving the Contractor of his full responsibility for the design, construction, monitoring, performance, and maintenance of the care of water plan.

### 26.3.3 Excavation

Excavation shall be completed to the lines and grades shown on the Drawings or as determined by the Consultant, and in accordance with Section 1, Excavation.

Excavations shall be dewatered to the bottom of the excavation until all backfilling is acceptably completed.

### 26.3.4 Erection Procedure

The Contractor shall submit a detailed erection procedure for RCP structures with a diameter of 2 metres or greater and for all PBC structures to the Consultant for review and acceptance a minimum of three weeks in advance of the scheduled start of installation. The erection procedure shall be stamped by a Professional Engineer registered in the Province of Alberta. Safety and compliance with the Occupational Health and Safety Act and Regulations thereunder shall be integral parts of his design.

At a minimum the erection procedure shall include drawings and documentation necessary to acceptably communicate the following:

- Access to work;
- Type and capacity of equipment;
- Sequence of operation, including traffic accommodation, haul or transport truck, and crane positions;
- Detailed crane position on the ground with details of load distribution on wheels and outriggers;
- Details of section lifting, showing forces at lifting pins/lugs; and
- Details of temporary works for positioning and alignment of precast concrete sections.

The Contractor shall continue to be fully responsible for the results obtained by the use of the stamped erection procedure, with the Contractor's Professional Engineer also assuming responsibility, as the Contractor's Agent, for the results obtained. The Consultant's acceptance shall not be considered as relieving the Contractor of the responsibility for the safety of his methods or equipment, nor from carrying out the work in full accordance with the drawings and specifications.

### 26.3.5 Installation

#### 26.3.5.1 General

Installation of RCP and PBC structures shall not proceed until the excavation, foundation, and bedding material placement has been reviewed and accepted by the Consultant.

The Contractor shall install RCP and PBC sections to the lines and grades as shown on the Drawings, in accordance with the manufacturer's instructions and as determined by the Consultant.

RCP and PBC structures shall be installed from the lowest bedding elevation to the highest bedding elevation.

The tolerance from the grades shown on the Drawings or established by the Consultant shall not exceed  $\pm 15$  mm. The Contractor shall implement appropriate measures to control the grades to meet the tolerance requirements.

Under no circumstance shall the Contractor use an excavator or any other mechanical device or piece of equipment to push, pull, pound or rock RCP or PBC sections to achieve alignment. Sections shall not be dropped, dragged or rolled along the ground at any time.

The ends of each precast section shall be clean and dry of all dirt, oil, grease, and any foreign materials before joining sections together. Sections shall be firmly drawn together in a manner that results in a continuous, watertight conduit with a smooth and uniform interior surface. The joined sections shall accommodate for expansion, contraction, settlement, or lateral displacement requirements.

Allowable joint gap spacing between joined ~~box~~ sections shall not exceed 13 mm for RCP structures and 20 mm for PBC structures.

Contractor shall:

Install and join—If installed sections do not meet the specified alignment requirements, the sections shall be completely disassembled, bedding material adjusted, rubber gasket or sealants replaced and sections re-joined to the satisfaction of the Consultant

Defects identified at site shall be addressed in accordance with Subsection 26.2.10, Defects.

#### 26.3.5.2 Reinforced Concrete Pipe~~the~~

Installation of RCP shall include a rubber gasket at each joint between sections. The Contractor shall follow the rubber gasket manufacturer's ~~recommendations~~ storage and installation requirements.

- Install the precast box culvert from the lowest elevation to the highest elevation.
- Clean the inside of both ends prior to joint installation.
- Keep all rubber gaskets at room temperature and out of direct sunlight. ~~Gaskets shall be~~

~~free of dirt, oil and grease.~~

~~The Contractor shall use lifting clutches in conjunction with the with 3-legged chain sling (wire or link) for RCP sections with a diameter of 1050 mm or greater.~~

### 26.3.5.3 Precast Box Culvert

~~Installation of PBC shall include a flexible joint sealant or rubber gasket at each joint between sections. The Contractor shall follow the rubber gasket manufacturer's storage and installation requirements.~~

~~The Contractor shall use embedded lifting pins (anchors), lugs, or pins for PBC section installation. All lifting cavities shall be filled with an Overhead/Vertical (OH-V) concrete patching material listed on the Department's Product List once installation has been completed, reviewed and accepted by the Consultant.~~

- ~~• If the installed section is not on an acceptable grade, the section shall be completely unjoined, the grade corrected, and the box section then rejoined.~~

~~Under no circumstances shall the Contractor:~~

- ~~• Use an excavator, or any other mechanical device to push, pound, or rock the culvert to achieve the proper grade.~~
- ~~• Drag boxes along the ground to either stockpile or install the section.~~

### ~~26.2.5~~ 26.3.6 ~~26.3.4~~ Backfilling

~~When installation of the structure has been accepted by the Consultant, backfilling with granular and/or non-granular materials as the material(s) specified on the Drawings and in Section 26.3.2 may proceed commence. Backfilling shall be in accordance with the current version of the standard drawing S-1418 "Installation of Large Steel Pipes" Drawings and Section 2-"Backfill" of the Specifications for Bridge Construction. In addition, the following requirements shall be met:~~

- ~~• When the ambient air temperature is below 0 °C, no backfilling is allowed will be permitted unless otherwise accepted by the Department and the Consultant. When acceptance is granted, all backfill material shall be in a thawed state when placed and compacted. Backfill material shall not be placed on frozen substrate permitted;~~
- ~~• Backfilling under the haunches shall be compacted to achieve the density as per Section 26.3.2 "Bedding/Backfill"-specified;~~
- ~~• Backfilling shall be free of voids and provide uniform support to the structure. The backfill shall be placed such that the level of fill on one side does not exceed the level of fill on the other side of the structure by more than 300 mm.;~~



- ~~Should vibratory equipment be required,~~The backfill shall be placed and compacted by equipment moving parallel to the structure with simultaneous handwork along the structure. Large earth moving equipment and large compaction equipment shall not be permitted within 1 m of the structure. Any damage to the structure from compaction equipment used shall be repaired by the Contractor at his expense to the full satisfaction of the Consultant;
- ~~Clean material void of rocks and sharp objects shall be used from the springline of the structure to the road surface.~~
- ~~Should in situ material be used in place of granular material, the in situ material shall also extend to the springline of the structure as per the compaction required by the Consultant. The Consultant shall confirm the in situ material conforms to the type and compaction level as specified on the drawings.~~
- The Contractor shall supply suitable material for the~~The first 300 mm of backfill over the structure shall be placed, levelled and compacted without vibration. Subsequent fill over the structure shall be placed and compacted by equipment moving perpendicular to the longitudinal axis of the structure. The Contractor shall obtain the Consultant's acceptance before using any equipment above the structure.~~
- ~~For compacted non-granular backfill. Generally the material shall consist of clay or till materials, materials, the quality, methods of placement and compaction, shall be submitted to the Consultant for review and acceptance prior to the commencement of the Work. Highly plastic clay material or material with high silt content will not be permitted. The quality of the material, and the methods of placing and compacting, requires acceptance by the Consultant before commencement of this stage of construction.~~

#### **26.4 Fish Passage Infrastructure**

- ~~Fish passage infrastructure shall be~~Clay seal material shall be highly plastic clay with a minimum plasticity index of 40. Clay seal materials shall be classified in accordance with ASTM D2487.

#### **26.4 Substrate Holders**

~~Substrate holders shall be fabricated, installed and~~ constructed as shown on the Drawings and be fabricated in accordance with the applicable specifications.

#### **26.5 Rock Riprap**

~~Rock riprap shall be placed as shown on the drawings and shall conform to the Specifications for Bridge Construction Section 10 "Heavy Rock Riprap".~~

#### **26.6** ~~as outlined in the~~ **Measurement and Payment**

~~Unless otherwise specified on the drawings or in the "Special Provisions" payment for~~ of the following items: Contract.

- ~~Detour Road – Construct and Maintain~~
- ~~Salvage or Disposal of Existing Structure~~
- ~~Excavation~~
- ~~Reinforced Concrete Pipe or Precast Box Culvert – Supply~~
- ~~Granular Backfill – Des 6 Class 80~~
- ~~Crushed Granular Backfill – Des 2 Class 40~~
- ~~Non-Granular Backfill~~
- ~~Reinforced Concrete Pipe or Precast Box Culvert Installation~~
- ~~Fish Passage Infrastructure~~
- ~~Guardrail~~
- ~~Roadway Work~~

### ~~26.3~~ **26.5 Heavy Rock Riprap**

~~will Heavy rock riprap shall be placed as shown on the basis of Drawings and shall conform to the requirements of Section 10, Heavy Rock Riprap.~~

### **26.6 Post-Installation Inspection**

~~The Contractor and the Consultant shall jointly carry out a post-installation inspection after all backfilling is complete.~~

~~Joint gap measurements will be taken and recorded by the Consultant at all section joints.~~

~~All cracks will be identified, measured in width and length by the Consultant.~~

~~All defects shall be noted, recorded, and repaired or replaced by the Contractor in accordance with the requirements of this specification and to the satisfaction of the Consultant prior to the stream being re-routed through the new structure or being opened to pedestrian traffic.~~

#### **26.6.1 Reinforced Concrete Pipe**

~~A post-installation inspection will only be required for RCP structures with diameters of 1500 mm or larger.~~

~~Joint gap measurements inside the RCP structure will be taken and recorded by the Consultant at the locations of minimum and maximum gap at each section joint.~~

#### **26.6.2 Precast Box Culvert**

~~A post installation inspection will be required for all PBC structures.~~

~~Joint gap measurements inside the PBC structure will be taken and recorded by the Consultant at the locations of minimum and maximum gap along of the top, bottom, and both side surfaces at each section joint.~~

~~The inside alignment along the top, bottom, and both side surfaces at each section joint will be measured and recorded by the Consultant.~~

## 26.7 Measurement and Payment

~~Payment for the following items will be made at the applicable unit price or lump sum prices bid for each of these items of work, acceptably completed. Payment for the supply and installation of Reinforced Concrete Pipe or Precast Box Culvert will be based on the unit price bid per metre in place. The prices bid shall include:~~

- ~~• Detour Road - Construct and Maintain;~~
- ~~• Demolition, Disposal and Salvage of Existing Structure;~~
- ~~• Excavation;~~
- ~~• RCP – Supply;~~
- ~~• PBC – Supply;~~
- ~~• Crushed Aggregate Backfill – Des 2 Class 25 or Des 2 Class 40;~~
- ~~• Non-Granular Backfill;~~
- ~~• RCP – Install;~~
- ~~• PBC – Install;~~
- ~~• Substrate Holders;~~
- ~~• Guardrail;~~
- ~~• Roadway Work; and~~
- ~~• Heavy Rock Riprap.~~

~~Such payments will be full compensation for the cost of furnishing all labour, materials, equipment, tools, and incidentals necessary to complete the Work as shown on the Drawings and to the satisfaction of the Consultant.~~

~~When materials are delivered to the worksite, Unit price payments for: “Reinforced Concrete Pipe or Precast Box Culvert” will be based on actual quantities acceptably completed and remaining in the Work, as determined by the Consultant.~~

~~Payment for “RCP – Supply” and “PBC – Supply” will be made to a maximum of 90% of the cost of the materials based upon lump sum or unit price bid once the applicable supplier’s invoices. Payments will not be initiated until the Contractor submits the invoices to the Consultant upon receipt and acceptance of the material at the materials have been acceptably supplied and delivered to the project site. The remaining payment 10% of the lump sum or unit price bid will be made after once the structure is has been acceptably backfilled and installation tolerances have been measured, reviewed and accepted by the Consultant.~~

~~When woven All costs associated with the supply and installation of geotextile filter fabric is, when specified, the supply, placing, equipment and tools necessary to acceptably complete this work will be will be considered incidental to the Work, and no separate or additional payment for this will be made.~~

~~All cost associated with the care of water and/or ice will be considered incidental work to the Work, and no separate or additional payment will be made.~~

~~When woven geotextile filter fabric is not specified but deemed necessary as determined by the Consultant due to unsuitable foundation conditions, the supply, placing and the related work will be paid for by a negotiated lump sum price or in accordance with 1.2.25 "Extra Work" of the General Specification as determined by the Consultant.~~