

**BANDED GRATING COVER AND COVER SUPPORT**

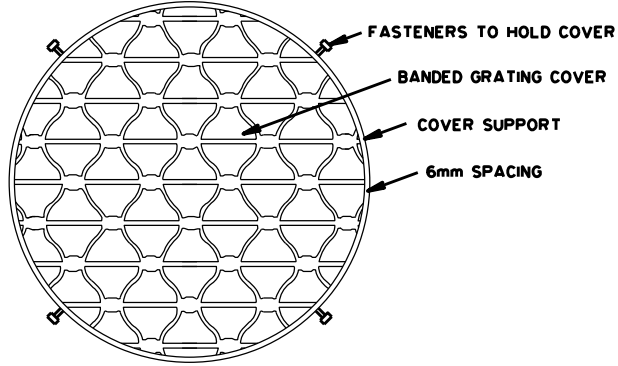

NOTES: DEPTHS OF DROP INLETS SHOWN BELOW ARE STANDARD, LARGER DIAMETER OUTLET PIPES WOULD INCREASE DEPTHS.

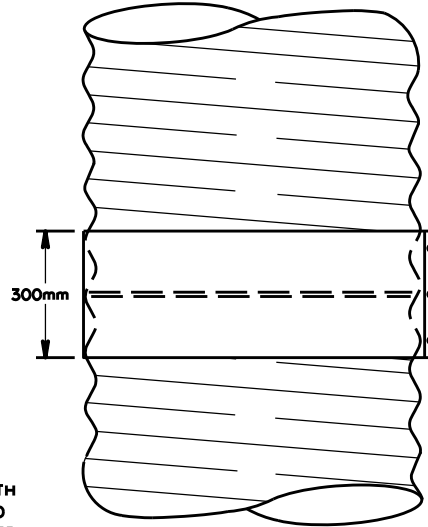

**DETAILS OF 300 mm WATERTIGHT COUPLER**

COUPLER FASTENING SHALL BE PERFORMED BY DRAWING THE ENDS TOGETHER WITH BOLTS OR WEDGES TO OBTAIN A TIGHT SEAL.

**SHALLOW TYPE TYPICAL DROP INLET**

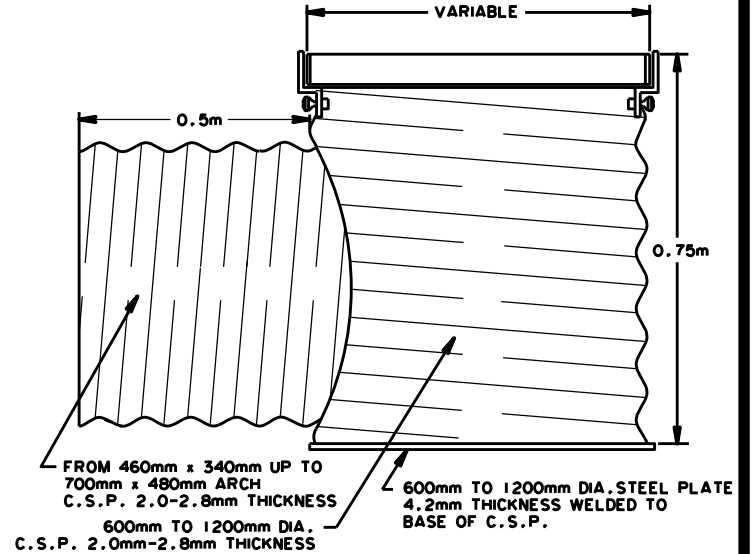

NOTE: STANDARD DEPTH OF DROP INLET ASSEMBLY (STANDARD TYPE) IS 1.45m AND (SHALLOW TYPE) IS 0.75m

**STANDARD TYPICAL DROP INLET**

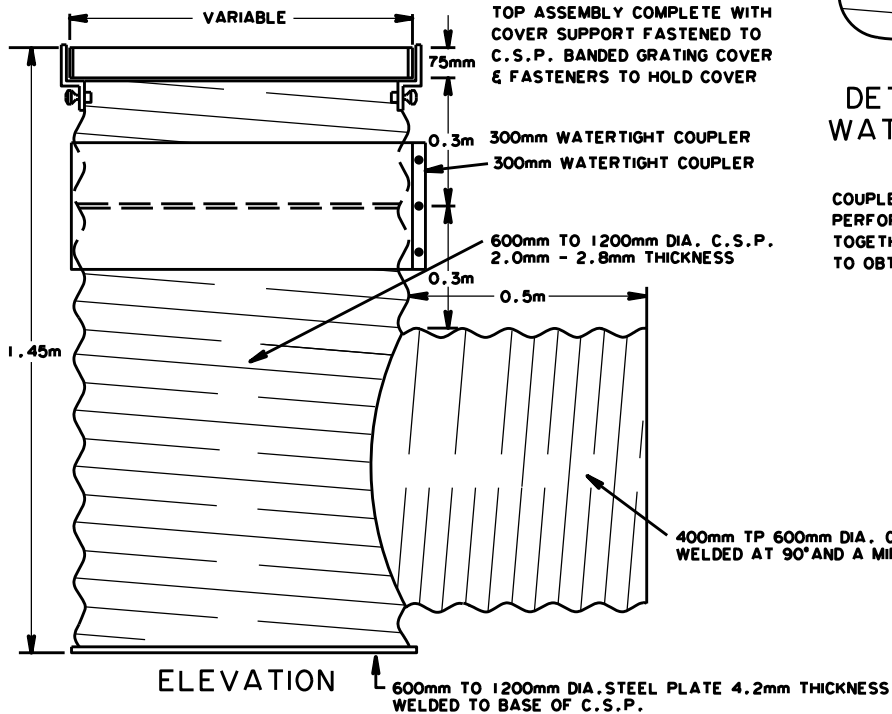

TOP ASSEMBLY COMPLETE WITH COVER SUPPORT FASTENED TO C.S.P. BANDED GRATING COVER & FASTENERS TO HOLD COVER

300mm WATERTIGHT COUPLER  
300mm WATERTIGHT COUPLER

600mm TO 1200mm DIA. C.S.P. 2.0mm - 2.8mm THICKNESS

400mm TP 600mm DIA. C.S.P. 2.0mm - 2.8mm THICKNESS WELDED AT 90° AND A MINIMUM OF 75mm OFF BASE

	DWG. NO.	CB-6 2.4.M13
	Origin	April 1979
	Revised	Nov. 1980 Feb. 1985

TYPICAL SECTION  
CORRUGATED STEEL PIPE  
DROP INLET ASSEMBLIES

OBSOLETE  
March 2022