

**Part 1 - Dimension Limits**

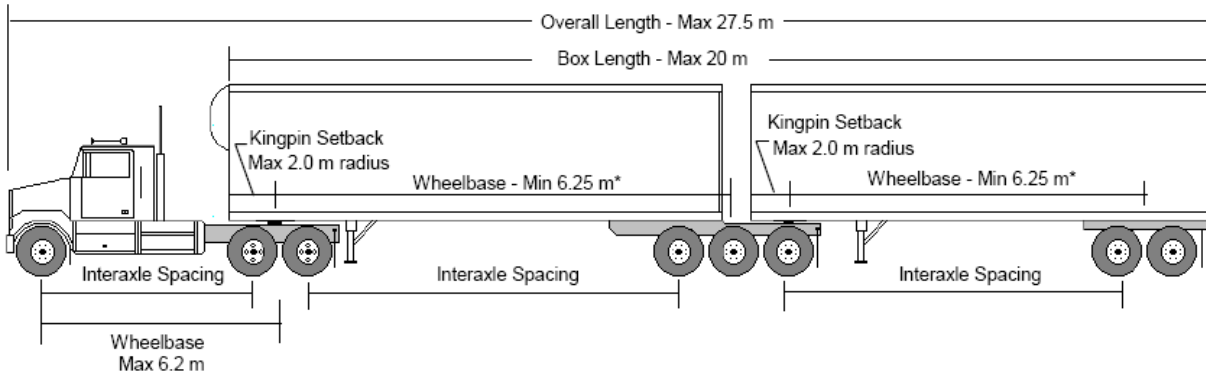

DIMENSION	LIMIT
<b>Overall Length****</b>	Maximum 27.5 m
<b>Overall Width</b>	Maximum 2.6 m
<b>Overall Height</b>	Maximum 4.15 m
<b>Box Length</b>	Maximum 20.0 m
<b>Tractor:</b>	
Wheelbase	Maximum 6.2 m
<b>Lead Semitrailer</b>	
Wheelbase	Minimum 6.25 m
Kingpin setback	Maximum 2.0 m radius
Track width	Minimum 2.5 m / Maximum 2.6 m
Effective rear overhang	Maximum 35% of wheelbase
Fifth wheel position	Maximum 0.3 m behind the centre of the rearmost axle of trailer.
<b>Second Semitrailer</b>	
Wheelbase	Minimum 6.25 m
Kingpin setback	Maximum 2.0 m radius
Track width	Minimum 2.5 m / Maximum 2.6 m
<b>Axle Spreads</b>	
Tandem axle	Minimum 1.2 m / Maximum 1.85 m
Tridem axle	Minimum 2.4 m / Maximum 3.1 m
<b>Interaxle Spacings</b>	
Single axle to single or tandem axle	Minimum 3.0 m
Tandem axle to tandem axle	Minimum 5.0 m
Tandem axle to tridem axle	Minimum 5.5 m
Tridem axle to tridem axle	Minimum 5.5 m

Note: The sum of the wheelbases of the two trailers cannot exceed 17.0 metres.

**Part 2 - Weight Limits**

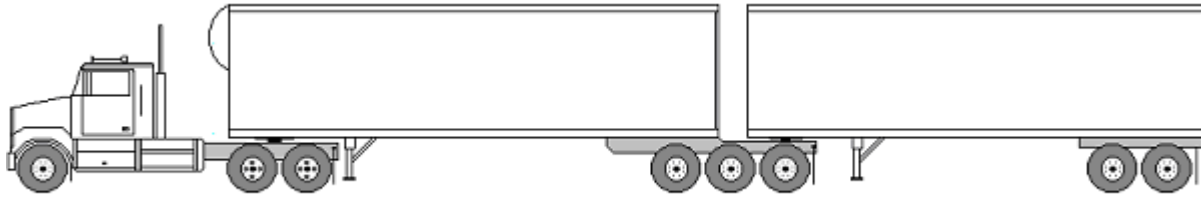

WEIGHT	LIMIT
<b>Axle Weights:***</b>	
<b>Steering Axle</b>	Maximum 6000 kg
<b>Single Axle</b>	
Single tires	Maximum 7300 kg
Super single tires	Maximum 7700 kg *
Dual tires	Maximum 9100 kg
<b>Tandem Axle:</b>	
Single tires	Maximum 13,600 kg
Super single tires	Maximum 15,400 kg *
Dual tires	Maximum 17,000 kg
<b>Tridem Axle:</b>	
Single and super single tires	Maximum 19,000 kg **
Dual tires with axle spread 2.4 m to less than 3.0 m	Maximum 21,000 kg **
Dual tires with axle spread 3.0 m to 3.1 m	Maximum 24,000 kg **
<b>Gross Vehicle Weight Limits</b>	
See weight calculator	Maximum GVW of 63,500 kg **

\* Super single tires require “New Generation, Wide Base” tires with a minimum tire width of 445 mm. Available by permit only. Super single tires do not apply to the steering axle.

\*\* The weights for tridem axles and the GVW apply to provincial highways only. The maximum weight for a tridem axle on a municipal road is 17,000 kg and the maximum GVW is 53,500 kg. Permits may be available to achieve heavier weights.

\*\*\* All axle weights are subject to minimum tire size. The maximum weight per tire shall not exceed the lesser of the tire manufacturer’s weight rating or the width of the tire stamped on the sidewall multiplied by 10 kg/mm.

\*\*\*\* Maximum overall length without permit is 26.0 metres. Maximum overall length with permit is 27.5 metres including any heavy duty bumpers.