

**DRAFT: SEPTEMBER 29, 2006
(INCLUDES ADDENDA 1 TO 11)**

SCHEDULE 18

TECHNICAL REQUIREMENTS

Table of Contents

100.0 GENERAL.....	1
100.1 INTRODUCTION.....	1
100.1.1 DEFINITIONS.....	2
100.2 MANAGEMENT SYSTEMS AND PLANS.....	4
100.2.1 QUALITY MANAGEMENT SYSTEM.....	4
100.2.1.1 Design.....	4
100.2.1.2 Construction.....	5
100.2.1.3 Operations.....	6
100.2.1.4 Audits.....	7
100.2.1.4.1 Internal Audit.....	7
100.2.1.4.2 External Audit.....	7
100.2.2 ENVIRONMENTAL MANAGEMENT SYSTEM.....	8
100.2.2.1 Monitoring and Inspection Programs.....	8
100.2.2.2 Internal Audit.....	9
100.2.2.3 External Audit.....	9
100.2.3 HANDLING OF QMS/EMS NON-CONFORMANCE.....	10
100.2.4 PROJECT SCHEDULE.....	10
100.2.5 TRAFFIC MANAGEMENT PLAN.....	10
100.2.6 SAFETY PLAN.....	11
100.2.7 PUBLIC COMMUNICATION STRATEGIES.....	11
100.2.8 CONSTRUCTION MANAGEMENT PLAN.....	12
100.2.9 OPERATION AND MAINTENANCE PLAN.....	12
100.2.9.1 Payment Adjustments.....	12
100.2.10 INFRASTRUCTURE WHOLELIFE MANAGEMENT PLAN.....	13
100.2.10.1 Payment Adjustments.....	13
100.3 DEPARTMENT REVIEW.....	14
200.0 PROJECT SPECIFICS.....	15
200.1 INFRASTRUCTURE LIMITS.....	16
200.1.1 NEW INFRASTRUCTURE.....	16
200.1.2 EXISTING INFRASTRUCTURE.....	16
200.2 DESIGN AND CONSTRUCTION OF NEW INFRASTRUCTURE.....	17
200.2.1 GENERAL.....	17
200.2.2 GEOMETRIC DESIGN.....	19
200.2.3 DESIGN SPECIFICS.....	26
200.2.3.1 City of Calgary Responsibility.....	26
200.2.3.2 Intentionally deleted.....	26
200.2.3.3 Roadway Mainline.....	26
200.2.3.4 Crossroads.....	26
200.2.3.5 Bridge Sections.....	27
200.2.3.6 Deerfoot Trail/Stoney Trail Interchange.....	27
200.2.3.7 36 th Street NE.....	29
200.2.3.8 Métis Trail NE Interchange.....	30
200.2.3.9 60 th Street NE Interchange.....	30

200.2.3.10	Future System Interchange in Sec 36-25-29-4.....	31
200.2.3.11	Country Hills Boulevard Interchange	31
200.2.3.12	Airport Trail NE Interchange.....	32
200.2.3.13	McKnight Boulevard Interchange.....	32
200.2.3.14	16th Avenue/Stoney Trail Interchange	32
200.2.3.15	Stoney Trail Grade Separating Bridges over CN.....	34
200.2.3.16	17 th Avenue SE	34
200.2.3.17	Highway 1 (Trans Canada Highway) Bridges over CN Railway	35
200.2.3.18	Service Roads.....	36
200.2.3.19	Intentionally Deleted.....	37
200.2.3.20	Road Closures	37
200.2.3.21	Closure of Highway 1 & 84 Street NE Intersection and Signalization of Highway 1 & 100 Street NE Intersection.....	37
200.2.3.22	Intentionally Deleted.....	38
200.2.3.23	Detours.....	39
200.2.3.24	Demolition	40
200.2.4	MISCELLANEOUS DESIGN REQUIREMENTS	40
200.2.5	DRAINAGE	41
200.2.6	ROADWAY LIGHTING.....	42
200.2.7	GUIDE SIGNING (OVERHEAD).....	43
200.2.8	LANDSCAPING.....	44
200.2.9	TOPSOIL AND SEEDING.....	44
200.2.10	UTILITIES	46
200.2.11	RAILWAYS.....	49
200.2.12	MUNICIPAL AUTHORITIES	49
200.2.13	ENVIRONMENTAL	50
200.2.14	NOISE ATTENUATION.....	50
200.2.15	FENCING.....	50
200.2.16	PREFERENTIAL BRIDGE DECK ICING	51
200.2.17	INTENTIONALLY DELETED.....	53
200.2.18	MISCELLANEOUS ENVIRONMENTAL CONCERNS.....	53
200.2.18.1	Wetland Compensation.....	53
200.2.18.2	Campsites.....	53
200.2.18.3	Burning	53
200.2.18.4	Historical Resources	53
200.2.18.5	Pollutants.....	53
200.2.18.6	Topsoil	53
200.2.18.7	Organic Materials.....	54
200.2.19	AESTHETICS.....	54
200.3	OPERATION AND MAINTENANCE OF THE INFRASTRUCTURE ...	55
200.3.1	TRAFFIC VOLUME PAYMENT ADJUSTMENTS.....	55
200.3.2	SNOW AND ICE CONTROL	56
200.3.3	Intentionally deleted.....	56
200.3.4	WEED CONTROL AND LANDSCAPE MAINTENANCE	56
200.3.4.1	General.....	56
200.3.4.2	Method	57
200.3.4.3	Weed Control Signage and Notification.....	57
200.3.4.4	Mowing and Fence Trimming	58

200.3.4.5	Seed Establishment and Maintenance of Seeded Areas	58
200.3.5	MAINTENANCE OF DRAINAGE SYSTEMS.....	59
200.3.6	LEVEL 2 BRIDGE DECK INSPECTIONS	59
200.3.7	PREVENTATIVE BRIDGE MAINTENANCE.....	60
200.3.8	INtentionally deleted	60
200.3.9	SPECIAL EVENTS	60
200.3.9.1	Full Lane Availability Events	60
200.3.9.2	Partial or Full Closure Events.....	60
200.4	MISCELLANEOUS.....	62
200.4.1	CITY OF cALGARY	62
200.4.2	HOURS OF WORK / WORK RESTRICTIONS.....	62
200.4.3	cOORDINATION WITH LOCAL AUTHORITIES	62
200.4.4	POLICE AND FIRE SERVICES.....	62
200.4.5	LAND ISSUES.....	63
200.4.6	LAND REQUIREMENTS IN THE EXISTING TUC.....	63
200.4.7	intentionally deleted	63
200.4.8	WORK BY OTHER FORCES.....	63
200.4.9	VEHICLE INSPECTION SERVICES.....	64
200.4.10	SURVEY	64
300.0	DESIGN AND CONSTRUCTION - NEW INFRASTRUCTURE	65
300.1	INTRODUCTION.....	66
300.2	DESIGN - GENERAL.....	67
300.2.1	GENERAL DESIGN REQUIREMENTS	67
300.2.2	RESPONSIBILITY FOR DESIGN.....	67
300.2.3	DESIGN DOCUMENTATION	67
300.2.4	AESTHETICS	68
300.2.5	PROVISIONS FOR FUTURE STAGES.....	69
300.2.6	ROADWAY SAFETY AUDITS	69
300.3	CONSTRUCTION - GENERAL.....	70
300.3.1	RESPONSIBILITY FOR CONSTRUCTION	70
300.3.2	TRAFFIC MANAGEMENT.....	70
300.3.3	AS-BUILT Information.....	70
300.3.3.1	As-Built Roadway Construction Report.....	71
300.3.3.2	As-Built Surfacing Information	71
300.3.3.3	As-Built Pavement Structural Information	72
300.3.3.4	As-Built Construction Report - Bridge Structures.....	72
300.3.3.5	As-Built Drawings	73
300.4	ROADWAYS.....	74
300.4.1	DESIGN REQUIREMENTS	74
300.4.1.1	Geometric Design	74
300.4.1.2	Intersections and Interchanges.....	74
300.4.1.3	Soils.....	74
300.4.1.4	Drainage.....	75
300.4.1.5	Hazard Protection.....	75
300.4.1.6	Roadway Lighting.....	75
300.4.1.7	Landscaping	76
300.4.1.8	Pavement Structure	76
300.4.1.8.1	Pavement Design Report.....	76

300.4.1.9	Traffic Control Devices	77
300.4.1.9.1	Signs	77
300.4.1.9.2	Traffic Signals	77
300.4.1.9.3	Pavement Markings	78
300.4.1.10	Miscellaneous	78
300.4.1.10.1	Fencing	78
300.4.2	MATERIALS	78
300.4.2.1	Topsoil	79
300.4.2.2	Aggregates	79
300.4.2.3	Portland Cement Concrete	79
300.4.2.4	Asphalt	79
300.4.2.5	Fencing Materials.....	80
300.4.2.6	Reinforced Concrete Pipe	80
300.4.2.7	Polyvinyl Chloride Pipe.....	80
300.4.2.8	Smooth Walled Steel Pipes.....	80
300.4.2.9	Corrugated Metal Pipe And Pipe Arches.....	80
300.4.2.10	Curbs, Gutters, Medians, Traffic Islands, Sidewalks and Other Appurtenances.....	81
300.4.2.11	Permanent Highway Signs, Posts and Bases	81
300.4.2.11.1	Reflective Sheeting.....	81
300.4.2.11.2	Sign Posts	81
300.4.2.12	Pavement Marking Materials.....	81
300.4.2.13	Guardrail and Posts	82
300.4.2.14	Intentionally Blank.....	82
300.4.2.15	Flexible Guide Post Traffic Delineators	82
300.4.2.16	Intentionally Blank.....	82
300.4.2.17	Underground Electrical Conduit and Cable Ducts.....	82
300.5	BRIDGE STRUCTURES	83
300.5.1	GENERAL	83
300.5.1.1	Existing Reference Documents	83
300.5.2	DESIGN CRITERIA	83
300.5.2.1	Design Codes	83
300.5.2.2	Design Load.....	86
300.5.2.3	Hydrotechnical.....	86
300.5.2.3.1	Minimum Freeboard for Stream Crossings	86
300.5.2.4	Geotechnical	86
300.5.2.5	Geometrics	87
300.5.2.6	Preferential Bridge Deck Icing	88
300.5.2.7	Durability	88
300.5.2.8	Pier Foundations	89
300.5.2.9	Sign Structures	89
300.5.2.10	Retaining Wall Structures	90
300.5.2.11	Bridge Plaques	90
300.5.2.12	Utility Accommodation	90
300.5.2.13	Clearance Signs.....	90
300.5.3	DESIGN REPORT REQUIREMENTS	90

300.5.4	FINAL DESIGN REPORT REQUIREMENTS	91
300.5.5	CONSTRUCTION REQUIREMENTS	92
300.5.5.1	General.....	92
300.5.5.1.1	Materials	92
300.5.5.1.2	Existing Reference Documents	92
300.5.6	CONSTRUCTION CRITERIA.....	92
300.5.6.1	Specifications For Bridge Construction.....	92
300.5.6.1.1	Cast-In-Place Concrete	92
300.5.6.1.2	Structural Steel	92
300.5.6.1.3	Precast Concrete Units.....	92
300.5.6.1.4	CSP and SPCSP Structures.....	92
300.5.6.1.5	Intentionally Deleted	93
300.5.6.1.6	Sign Structures.....	93
300.5.6.1.7	Piling.....	93
300.5.6.1.8	Reinforcing Steel	93
300.5.6.1.9	Waterproofing Membrane	93
300.5.6.1.10	Alternatives to Supplemental Specifications	93
300.5.7	CAST-IN-PLACE CONCRETE	93
300.5.7.1	General.....	93
300.5.7.2	Submissions	93
300.5.7.3	Reference Drawings (as attached after Section 300.5.7.18.6)	94
300.5.7.4	Materials For Concrete	94
300.5.7.5	Class and Composition Of Concrete.....	95
300.5.7.5.1	Class of Concrete.....	95
300.5.7.5.2	Class HPC and Class HPC with Steel Fibres	95
300.5.7.5.3	Temperature.....	97
300.5.7.5.4	Aggregate Tests and Concrete Mix Design.....	97
300.5.7.5.5	Initial Mixes and Adjustments.....	98
300.5.7.6	Mixing Concrete	99
300.5.7.6.1	Truck Mixing.....	99
300.5.7.6.2	Time of Hauling.....	99
300.5.7.6.3	Delivery	99
300.5.7.7	Inspection and Testing.....	99
300.5.7.7.1	Strength Tests	100
300.5.7.7.2	Sampling.....	100
300.5.7.7.3	Test Cylinders.....	100
300.5.7.7.4	Slump.....	101
300.5.7.7.5	Air Content	101
300.5.7.7.6	Testing Cylinders.....	101
300.5.7.7.7	Failure to Meet Slump or Air Content Specifications	101
300.5.7.8	Falsework and Formwork	101
300.5.7.8.1	General.....	101
300.5.7.8.2	Standard Details.....	102
300.5.7.8.3	Deck Formwork.....	102
300.5.7.9	Handling and Placing Concrete	102
300.5.7.9.1	General.....	102

300.5.7.9.2	Consolidation.....	102
300.5.7.9.3	Additional Requirements.....	102
300.5.7.9.4	Pumping.....	103
300.5.7.10	Placing Pile Concrete.....	103
300.5.7.10.1	General.....	103
300.5.7.10.2	Concrete Placed in the Dry.....	103
300.5.7.10.3	Concrete Placed Under Water.....	103
300.5.7.11	Placing Deck, Curb and Deck Overlay Concrete.....	104
300.5.7.11.1	General.....	104
300.5.7.11.2	Placing/Finishing Machines.....	104
300.5.7.11.3	Screed Guide Rails.....	104
300.5.7.11.4	Dry-Run.....	105
300.5.7.11.5	Fog Misting and Wet Cure Systems.....	105
300.5.7.11.6	Surface Defects and Tolerances.....	105
300.5.7.12	Construction Joints.....	106
300.5.7.12.1	General.....	106
300.5.7.13	Concreting In Cold Weather.....	106
300.5.7.14	Depositing Concrete Under Water.....	107
300.5.7.15	Curing Concrete.....	108
300.5.7.15.1	General.....	108
300.5.7.15.2	Curing Requirements for Concrete Slope Protection.....	108
300.5.7.15.3	Curing Requirements for Class HPC and Class HPC with Steel Fibres.....	108
300.5.7.15.4	Class HPC and Class HPC with Steel Fibres.....	109
300.5.7.16	Concrete Surface Finish.....	109
300.5.7.16.1	General.....	109
300.5.7.16.2	Class 1. Ordinary Surface Finish.....	110
300.5.7.16.3	Class 2. Rubbed Finish.....	111
300.5.7.16.4	Class 3. Bonded Concrete Surface Finish.....	111
300.5.7.16.5	Class 4. Floated Surface Finish.....	112
300.5.7.16.6	Class 5. Floated Surface Finish, Broomed Texture.....	112
300.5.7.16.7	Class 6. Floated Finish, Surface Textured.....	112
300.5.7.17	Sealer.....	112
300.5.7.18	Concrete Strength Requirements.....	113
300.5.7.18.1	Class B Concrete, Pile Concrete, 25 MPa.....	113
300.5.7.18.2	Class D Concrete, 30 MPa.....	113
300.5.7.18.3	Modified Class C Concrete, 35 MPa.....	114
300.5.7.18.4	Class HPC Concrete, 45 MPa.....	114
300.5.7.18.5	Class S Concrete, 20 MPa.....	114
300.5.7.18.6	Coring for Compressive Strength Testing.....	115
300.5.8	STRUCTURAL STEEL.....	118
300.5.8.1	General.....	118
300.5.8.2	Submissions.....	118
300.5.8.3	Supply and Fabrication.....	118
300.5.8.3.1	Standards.....	118
300.5.8.3.2	Qualification.....	119

300.5.8.3.3	Engineering Data	119
300.5.8.4	Materials	120
300.5.8.4.1	Welding	121
300.5.8.4.2	Fabrication	122
300.5.8.4.3	Surface Preparation	126
300.5.8.4.4	Testing and Inspection	126
300.5.8.5	Structural Steel Erection	128
300.5.8.5.1	Handling and Storing Materials	129
300.5.8.5.2	Bridge Girders	129
300.5.9	PRECAST CONCRETE UNITS	134
300.5.9.1	General	134
300.5.9.2	Submissions	134
300.5.9.3	Reference Drawing (attached after Section 300.5.9.10.13)	134
300.5.9.4	Supply and Manufacture	134
300.5.9.4.1	Standards	134
300.5.9.4.2	Qualification	135
300.5.9.5	Engineering Data	135
300.5.9.6	Materials	136
300.5.9.7	Manufacture	138
300.5.9.8	Testing and Inspection	143
300.5.9.9	Failure To Meet Strength Requirements	144
300.5.9.10	Erection of Precast Concrete Girders	144
300.5.9.10.1	General	144
300.5.9.10.2	Handling And Storing Materials	145
300.5.9.10.3	Temporary Supporting Structures And Berms	145
300.5.9.10.4	Erection Procedure	145
300.5.9.10.5	Girder Adjustments	147
300.5.9.10.6	Grout Pockets And Grout Pads	147
300.5.9.10.7	Grouting In Cold Weather	147
300.5.9.10.8	Bearings and Anchorage	148
300.5.9.10.9	Assembly	148
300.5.9.10.10	Lifting Hooks and Lifting Holes	148
300.5.9.10.11	Painting of Metal Parts	148
300.5.9.10.12	Post-Tensioning	148
300.5.9.10.12.1	General	148
300.5.9.10.12.2	Submissions	149
300.5.9.10.12.3	Standards	149
300.5.9.10.12.4	Qualification	149
300.5.9.10.12.5	Materials	149
300.5.9.10.12.6	Equipment	150
300.5.9.10.12.7	Construction	151
300.5.9.10.13	Removal of Falsework and Site Clean-Up	153
300.5.10	CONSTRUCTION OF CSP AND SPCSP STRUCTURES	155
300.5.10.1	General	155
300.5.10.2	Submissions	155
300.5.10.3	Reference Drawings (attached after Section 300.5.10.9)	155

300.5.10.4	Reference Tables (attached after Section 300.5.10.9)	155
300.5.10.5	Supply and Fabrication	155
300.5.10.5.1	Standards	155
300.5.10.5.2	Engineering Data	156
300.5.10.5.3	Materials	156
300.5.10.5.4	Fabrication	156
300.5.10.5.5	Shop Inspection	157
300.5.10.5.6	Storage of Material	157
300.5.10.5.7	Handling of Material	157
300.5.10.6	Installation	158
300.5.10.6.1	Bedding	158
300.5.10.6.2	Assembly	159
300.5.10.6.3	Backfilling	160
300.5.10.6.4	Strutting for Composite Concrete/SPCSP Structure	160
300.5.10.7	Concrete Work	160
300.5.10.8	Fish Baffles	160
300.5.10.9	Rock Riprap	160
300.5.11	INTENTIONALLY DELETED	165
300.5.12	SIGN STRUCTURES	165
300.5.12.1	General	165
300.5.12.2	Submissions	165
300.5.12.3	Reference Drawings (attached after Section 300.5.12.7)	165
300.5.12.4	Engineering Data	165
300.5.12.5	Supply and Fabrication	166
300.5.12.5.1	Standards	166
300.5.12.5.2	Qualification	166
300.5.12.5.3	Engineering Data	166
300.5.12.5.4	Materials	167
300.5.12.5.5	Welding	167
300.5.12.5.6	Fabrication	169
300.5.12.5.7	Testing and Inspection	171
300.5.12.5.8	Identification Tag	172
300.5.12.6	Erection	172
300.5.12.7	Foundation	173
300.5.13	PILING	176
300.5.13.1	General	176
300.5.13.2	Submittals	176
300.5.13.3	Reference Drawings (attached after Section 300.5.13.7.8)	176
300.5.13.4	Materials	176
300.5.13.4.1	Steel “H” Piling	176
300.5.13.4.2	Steel Pipe Piling	176
300.5.13.4.3	Timber Piling	177
300.5.13.4.4	Pile Concrete	177
300.5.13.4.5	Reinforcing Steel	177
300.5.13.5	Handling	177
300.5.13.6	Driven Bearing Piles	178

300.5.13.6.1	Equipment and Driving Methods.....	178
300.5.13.6.2	Bearing Values.....	178
300.5.13.6.3	Steel Piles.....	179
300.5.13.6.4	Defective Piles.....	180
300.5.13.7	Drilled Cast-in-place Concrete Bearing Piles.....	180
300.5.13.7.1	General.....	180
300.5.13.7.2	Equipment and Drilling Methods.....	180
300.5.13.7.3	Drilling Pile Holes.....	181
300.5.13.7.4	Open Drilled Holes.....	181
300.5.13.7.5	Reinforcement.....	181
300.5.13.7.6	Concrete Placement.....	182
300.5.13.7.7	Cold Weather Conditions.....	182
300.5.13.7.8	Pile Tolerance.....	182
300.5.14	REINFORCING STEEL.....	186
300.5.14.1	General.....	186
300.5.14.2	Certification.....	186
300.5.14.3	Fabrication.....	186
300.5.14.4	Handling and Storage.....	186
300.5.14.5	Field Repair of Epoxy Coating.....	187
300.5.14.6	Placing and Fastening.....	187
300.5.14.7	Splicing.....	188
300.5.15	WATERPROOFING MEMBRANE.....	188
300.5.15.1	General.....	188
300.5.15.2	Reference Drawings (as attached after Section 300.5.15.9.3.4).....	188
300.5.15.3	Materials.....	188
300.5.15.4	Equipment.....	189
300.5.15.5	Installation.....	189
300.5.15.5.1	Traffic Restrictions.....	189
300.5.15.5.2	Procedure.....	189
300.5.15.5.3	Surface Preparation.....	190
300.5.15.5.4	Waterproofing of Joints and Cracks.....	190
300.5.15.5.5	Waterproofing Around Deck Drip Tubes.....	190
300.5.15.5.6	Application of Asphalt Membrane.....	191
300.5.15.5.7	Application of Protection Board.....	191
300.5.15.6	Sampling and Testing.....	191
300.5.15.7	List of Approved Materials.....	192
300.5.15.7.1	Hot Applied Rubberized Asphalt Membrane.....	192
300.5.15.7.2	Rubber Membrane.....	192
300.5.15.7.3	Waterproofing Protection Board.....	192
300.5.15.8	Paving Equipment and Methods.....	192
300.5.15.8.1	General.....	192
300.5.15.8.2	Paver.....	192
300.5.15.8.3	Compaction Equipment.....	193
300.5.15.9	Placement of Asphalt Concrete Pavement.....	193
300.5.15.9.1	Protection of Adjacent Bridge Components.....	193
300.5.15.9.2	Tack Coat.....	193

300.5.15.9.3	Spreading and Compaction	194
300.5.15.9.3.1	General	194
300.5.15.9.3.2	Spreading	194
300.5.15.9.3.3	Compaction	195
300.5.15.9.3.4	Hot-Applied Rubberized Membrane Waterproofing	196
400.0	OPERATIONS - NEW INFRASTRUCTURE.....	198
400.1	OPERATIONS - GENERAL.....	199
400.1.1	RESPONSIBILITY FOR OPERATIONS	199
400.1.2	MAINTENANCE AND REHABILITATION REQUIREMENTS.....	199
400.1.3	COMPLIANCE WITH PERFORMANCE REQUIREMENTS	200
400.1.3.1	Alternative Inspection and Testing Methods	201
400.1.4	APPEAL OF DEPARTMENT MEASUREMENTS	201
400.1.5	IMMINENT DANGER REPAIRS	201
400.1.6	LANE CLOSURE	202
400.1.7	IN-SERVICE SAFETY REVIEW	205
400.2	INSPECTION, EMERGENCY AND ROUTINE MAINTENANCE REQUIREMENTS	207
400.2.1	ROADWAY INSPECTIONS REQUIREMENTS	207
400.2.1.1	Routine Observations.....	207
400.2.1.2	Daily Road Reports.....	208
400.2.2	Emergency Maintenance	208
400.2.3	Routine Maintenance.....	209
400.2.4	Measuring For Compliance	210
400.2.5	Payment Adjustments.....	210
400.2.6	Reporting Procedures	211
400.3	WINTER MAINTENANCE OPERATION REQUIREMENTS	212
400.3.1	GENERAL	212
400.3.2	EQUIPMENT AND MATERIALS	214
400.3.3	SNOW CLEARING AND ICE CONTROL OPERATIONS	215
400.3.3.1	Measuring for Compliance	215
400.3.3.2	Non-Compliance.....	216
400.3.3.3	Payment Adjustments	216
400.3.4	PREFERENTIAL BRIDGE DECK ICING	217
400.3.4.1	Measuring for Compliance	217
400.3.4.2	Non-Compliance.....	217
400.3.4.3	Payment Adjustments	217
400.3.4.4	Plan Replacement.....	218
400.4	ROADWAYS	219
400.4.1	ROADWAY MAINTENANCE REQUIREMENTS	219
400.4.1.1	Measuring and Testing For Compliance.....	219
400.4.1.2	Completing Repairs	219
400.4.2	PAVEMENT GEOMETRIC REQUIREMENTS	220
400.4.2.1	Cross-Slope and Superelevation Rates	220
400.4.2.2	Pavement Widths	220
400.4.2.3	Measuring For Compliance.....	220
400.4.2.4	Payment Adjustments	221
400.4.3	SMOOTHNESS REQUIREMENTS.....	223
400.4.3.1	Measuring For Compliance.....	223

400.4.3.2	Payment Adjustments	224
400.4.4	RUTTING PERFORMANCE REQUIREMENTS	225
400.4.4.1	Measuring For Compliance.....	225
400.4.4.2	Payment Adjustments	226
400.4.5	SKID RESISTANCE REQUIREMENTS.....	226
400.4.5.1	Measuring For Compliance.....	227
400.4.5.2	Completing Repairs	227
400.4.5.3	Payment Adjustments	227
400.4.6	GENERAL PAVEMENT MAINTENANCE REQUIREMENTS.....	227
400.4.6.1	Localized Deficiencies.....	228
400.4.6.2	Localized Roughness	228
400.4.6.3	Measuring For Compliance.....	228
400.4.6.4	Completing Repairs	228
400.4.6.5	Payment Adjustments	228
400.4.7	MISCELLANEOUS - OPERATION AND PERFORMANCE REQUIREMENTS.....	229
400.4.7.1	Delineators	229
400.4.7.1.1	Measuring For Compliance	229
400.4.7.1.2	Completing Repairs	229
400.4.7.1.3	Payment Adjustments	230
400.4.7.2	Roadway Lighting.....	230
400.4.7.2.1	Measuring for Compliance	230
400.4.7.2.2	Completing Repairs	230
400.4.7.2.3	Payment Adjustments	231
400.4.7.3	Barriers and Guardrail.....	231
400.4.7.3.1	Measuring for Compliance	232
400.4.7.3.2	Completing Repairs	232
400.4.7.3.3	Payment Adjustments	232
400.4.7.4	Grass Cutting and Landscape Maintenance.....	232
400.4.7.4.1	General.....	232
400.4.7.4.2	Weed Control.....	233
400.4.7.4.2.1	Operating Standards, Approvals and Permits.....	233
400.4.7.4.2.2	Materials	233
400.4.7.4.2.3	Procedures	233
400.4.7.4.3	Measuring for Compliance	234
400.4.7.4.4	Completing Repairs	234
400.4.7.4.5	Payment Adjustments	234
400.4.7.5	Litter Clean Up	234
400.4.7.5.1	Measuring for Compliance	235
400.4.7.5.2	Completing Clean Up	235
400.4.7.5.3	Payment Adjustments	235
400.4.7.6	Drainage Systems.....	236
400.4.7.6.1	Measuring for Compliance	236
400.4.7.6.2	Completing Repairs	237
400.4.7.6.3	Payment Adjustments	237
400.4.7.7	Curb And Gutter	237

400.4.7.7.1	Measuring for Compliance	238
400.4.7.7.2	Completing Repairs	238
400.4.7.7.3	Payment Adjustments	238
400.4.7.8	Sidewalks	238
400.4.7.8.1	Measuring for Compliance	238
400.4.7.8.2	Completing Repairs	239
400.4.7.8.3	Payment Adjustments	239
400.4.7.9	Subgrade Sideslopes and Backslopes	239
400.4.7.9.1	Measuring for Compliance	239
400.4.7.9.2	Completing Repairs	239
400.4.7.9.3	Payment Adjustments	240
400.4.8	TRAFFIC CONTROL DEVICES - OPERATION AND PERFORMANCE REQUIREMENTS	240
400.4.8.1	Signs	240
400.4.8.1.1	Measuring for Compliance	241
400.4.8.1.2	Completing Repairs	241
400.4.8.1.3	Payment Adjustments	241
400.4.8.2	Traffic Signals	242
400.4.8.2.1	Measuring for Compliance	242
400.4.8.2.2	Completing Repairs	242
400.4.8.2.3	Payment Adjustments	243
400.4.8.3	Pavement Markings	243
400.4.8.3.1	Measuring for Compliance	244
400.4.8.3.2	Completing Repairs	244
400.4.8.3.3	Payment Adjustments	245
400.4.9	ROAD TRAFFIC NOISE MITIGATION	245
400.4.9.1	Measuring For Compliance	245
400.4.9.2	Completing Repairs	245
400.4.9.3	Payment Adjustments	246
400.5	BRIDGE STRUCTURES	247
400.5.1	OPERATIONS	247
400.5.1.1	General	247
400.5.1.2	Utility Accommodation	247
400.5.1.3	Performance Compliance Inspection and Testing	248
400.5.1.3.1	Inspections and Testing	248
400.5.1.3.2	Routine Level 1 Inspections	248
400.5.1.3.3	Specialized Level 2 Inspections	249
400.5.1.3.4	Inspection and Testing Notification	249
400.5.1.3.5	Inspection Reporting	250
400.5.1.3.6	Payment Adjustments	250
400.5.1.3.7	Traffic Accommodation	250
400.5.1.3.8	Measurement and Determination	250
400.5.2	BRIDGE MAINTENANCE AND OPERATIONS	251
400.5.2.1	General	251
400.5.2.2	Structural and Operational	251
400.5.2.3	Standard Maintenance	252

400.5.2.4	Preventative Bridge Structures Maintenance.....	252
400.5.2.5	Payment Adjustments	252
400.5.2.5.1	Structural and Operational.....	252
400.5.2.5.2	Standard Maintenance	252
400.5.2.5.3	Preventative Bridge Structures Maintenance	252
400.5.2.6	Bridge Structure Maintenance and Rehabilitation Requirements.....	253
400.5.2.7	Notification Of Bridge Structure Maintenance and Rehabilitation ..	253
400.5.3	PERFORMANCE REQUIREMENTS.....	253
400.5.3.1	General.....	253
400.5.3.2	Individual Component Requirements - Bridges	254
400.5.3.2.1	Approach Slab	254
400.5.3.2.2	Wearing Surface	254
400.5.3.2.3	Concrete Bridge Decks.....	254
400.5.3.2.4	Curbs, Barriers and Medians	255
400.5.3.2.5	Bridge and Pedestrian Rails.....	256
400.5.3.2.6	Deck Joints	256
400.5.3.2.7	Bridge Deck Drainage Systems.....	256
400.5.3.2.8	Concrete Girders.....	257
400.5.3.2.9	Steel Girders	257
400.5.3.2.10	Paint Protection System.....	257
400.5.3.2.11	Sidewalks.....	257
400.5.3.2.12	Bearings.....	257
400.5.3.2.13	Bearing Seats and Caps	258
400.5.3.2.14	Backwalls and Breastwalls	258
400.5.3.2.15	Wingwalls and Retaining Walls	259
400.5.3.2.16	Piers	259
400.5.3.2.17	Nose Plates	259
400.5.3.2.18	Concrete Finishes	260
400.5.3.2.19	Slope Protection for River Crossing.....	260
400.5.3.2.20	Slope Protection for Grade Separation	260
400.5.3.2.21	River Training Works.....	261
400.5.3.2.22	Other Bridge Structure Elements.....	261
400.5.3.3	Individual Component Requirements – Bridge Culverts.....	261
400.5.3.3.1	Embankments	261
400.5.3.3.2	Headwalls and Collars.....	261
400.5.3.3.3	Wingwalls.....	262
400.5.3.3.4	Cutoff Walls	262
400.5.3.3.5	Bevel Ends.....	262
400.5.3.3.6	Roofs.....	262
400.5.3.3.7	Sidewalls.....	263
400.5.3.3.8	Floors.....	263
400.5.3.3.9	Circumferential Seams	263
400.5.3.3.10	Longitudinal Seams	263
400.5.3.3.11	Coatings.....	264
400.5.3.3.12	Fish Passage Enhancement Features	264
400.5.3.3.13	Waterway Adequacy.....	264

400.5.3.3.14	Slope Protection.....	264
400.5.3.3.15	River Training Works.....	264
400.5.3.3.16	Other Bridge Culvert Structure Elements.....	264
400.5.3.4	Individual Component Requirements - Sign Structures	265
400.5.3.4.1	Pedestal.....	265
400.5.3.4.2	Column	265
400.5.3.4.3	Connections/Bearings.....	265
400.5.3.4.4	Superstructure Elements	265
400.5.3.4.5	Coatings.....	266
400.5.3.4.6	Other Sign Structure Elements	266
500.0	OPERATIONS - EXISTING INFRASTRUCTURE	267
500.1	OPERATIONS - GENERAL.....	268
500.1.1	RESPONSIBILITY FOR OPERATIONS	268
500.1.2	MAINTENANCE AND REHABILITATION REQUIREMENTS.....	268
500.1.3	COMPLIANCE WITH PERFORMANCE REQUIREMENTS	268
500.1.3.1	Alternative Inspection and Testing Methods	269
500.1.4	APPEAL OF DEPARTMENT MEASUREMENTS	269
500.1.5	IMMINENT DANGER REPAIRS	270
500.1.6	LANE CLOSURE.....	270
500.2	INSPECTION, EMERGENCY AND ROUTINE MAINTENANCE REQUIREMENTS	274
500.2.1	ROADWAY INSPECTIONS.....	274
500.2.1.1	Routine Observations.....	274
500.2.1.2	Daily Road Reports.....	275
500.2.2	EMERGENCY MAINTENANCE.....	275
500.2.3	ROUTINE MAINTENANCE	276
500.2.4	MEASURING FOR COMPLIANCE.....	277
500.2.5	PAYMENT ADJUSTMENTS	277
500.2.6	REPORTING PROCEDURES.....	278
500.3	WINTER MAINTENANCE OPERATION REQUIREMENTS.....	279
500.3.1	GENERAL	279
500.3.2	EQUIPMENT AND MATERIALS	282
500.3.3	SNOW CLEARING AND ICE CONTROL OPERATIONS	282
500.3.3.1	Measuring For Compliance.....	283
500.3.3.2	Non-Compliance.....	283
500.3.3.3	Payment Adjustments	283
500.3.4	PREFERENTIAL BRIDGE DECK ICING	284
500.3.4.1	Measuring for Compliance	284
500.3.4.2	Non-Compliance.....	284
500.3.4.3	Payment Adjustments	284
500.3.4.4	Plan Replacement.....	285
500.4	ROADWAYS	286
500.4.1	GENERAL PAVEMENT MAINTENANCE REQUIREMENTS.....	286
500.4.1.1	Localized Deficiencies.....	286
500.4.1.2	Localized Roughness	286
500.4.1.3	Localized Cracking – Asphalt Concrete Pavements.....	287
500.4.1.4	Localized Cracking – Portland Cement Concrete Pavements	287

Schedule 18 (Technical Requirements) – DBFO
Agreement

500.4.1.5	Measuring For Compliance.....	287
500.4.1.6	Completing Repairs	287
500.4.1.7	Payment Adjustments	287
500.4.2	MISCELLANEOUS OPERATION AND PERFORMANCE REQUIREMENTS	288
500.4.2.1	Delineators	288
500.4.2.1.1	Measuring For Compliance	288
500.4.2.1.2	Completing Repairs	289
500.4.2.1.3	Payment Adjustments	289
500.4.2.2	Roadway Lighting.....	289
500.4.2.2.1	Measuring For Compliance	289
500.4.2.2.2	Completing Repairs	289
500.4.2.2.3	Payment Adjustments	290
500.4.2.3	Barriers and Guardrail.....	290
500.4.2.3.1	Measuring For Compliance	290
500.4.2.3.2	Completing Repairs	291
500.4.2.3.3	Payment Adjustments	291
500.4.2.4	Grass Cutting and Landscape Maintenance.....	291
500.4.2.4.1	General.....	291
500.4.2.4.2	Weed Control.....	291
500.4.2.4.2.1	Operating Standards, Approvals and Permits.....	291
500.4.2.4.2.2	Materials	292
500.4.2.4.2.3	Procedures	292
500.4.2.4.2.4	Measuring For Compliance	292
500.4.2.4.2.5	Completing Repairs	293
500.4.2.4.2.6	Payment Adjustments	293
500.4.2.5	Litter Clean Up	293
500.4.2.5.1	Measuring For Compliance	294
500.4.2.5.2	Completing Clean Up	294
500.4.2.5.3	Payment Adjustments	294
500.4.2.6	Drainage Systems.....	295
500.4.2.6.1	Measuring For Compliance	295
500.4.2.6.2	Completing Repairs	295
500.4.2.6.3	Payment Adjustments	296
500.4.2.7	Curb and Gutter.....	296
500.4.2.7.1	Measuring For Compliance	296
500.4.2.7.2	Completing Repairs	297
500.4.2.7.3	Payment Adjustments	297
500.4.2.8	Sidewalks	297
500.4.2.8.1	Measuring For Compliance	297
500.4.2.8.2	Completing Repairs	297
500.4.2.8.3	Payment Adjustments	298
500.4.3	TRAFFIC CONTROL DEVICES - OPERATION AND PERFORMANCE REQUIREMENTS.....	298
500.4.3.1	Signs.....	298
500.4.3.1.1	Measuring For Compliance	298

500.4.3.1.2	Completing Repairs	299
500.4.3.1.3	Payment Adjustments	299
500.4.3.2	Traffic Signals	299
500.4.3.2.1	Measuring For Compliance	300
500.4.3.2.2	Completing Repairs	300
500.4.3.2.3	Payment Adjustments	300
500.4.3.3	Pavement Markings	301
500.4.3.3.1	Measuring For Compliance	302
500.4.3.3.2	Completing Repairs	302
500.4.3.3.3	Payment Adjustments	302
500.4.4	TESTING CONDUCTED WITH AN INERTIAL PROFILER	303
500.4.4.1	Measuring For Compliance	303
500.4.4.2	Payment Adjustments	303
500.5	BRIDGE STRUCTURES	304
500.5.1	GENERAL	304
500.5.2	UTILITY ACCOMMODATION	304
500.5.3	PERFORMANCE COMPLIANCE INSPECTION AND TESTING	304
500.5.3.1	Inspections and Testing	304
500.5.3.1.1	Routine Level 1 Inspections	305
500.5.3.1.2	Specialized Level 2 Inspections	305
500.5.3.1.3	Inspection and Testing Notification	306
500.5.3.1.4	Inspection Reporting	306
500.5.3.1.5	Payment Adjustments	306
500.5.3.2	Traffic Accommodation	307
500.5.3.3	Measurement And Determination	307
500.5.4	BRIDGE MAINTENANCE AND OPERATIONS	307
500.5.4.1	General	307
500.5.4.2	Preventative Bridge Structures Maintenance	307
500.5.5	Payment Adjustments	308
500.5.5.1	Preventative Bridge Structures Maintenance	308
600.0	HANDBACK REQUIREMENTS	309
600.1	ROADWAY HANDBACK REQUIREMENTS - NEW INFRASTRUCTURE	310
600.1.1	CONDITION OF PAVEMENT	310
600.1.2	PAVEMENT SURFACE CONDITION	310
600.1.3	STRUCTURAL REQUIREMENTS	310
600.1.4	CONDITION OF ALL SIGNS	311
600.1.5	CONDITION OF GUARDRAIL	311
600.1.6	CONDITION OF BARRIERS	312
600.1.7	CONDITION OF LIGHTING	312
600.1.8	CONDITION OF TRAFFIC SIGNALS	312
600.1.9	CONDITION OF THE DRAINAGE SYSTEM	313
600.1.10	CONDITION OF CONCRETE CURBS, GUTTERS, SIDEWALKS, BARRIERS (NON-STRUCTURE RELATED)	313
600.1.11	CONDITION OF LANDSCAPING	313
600.1.12	CONDITION OF FENCING	313
600.1.13	CONDITION OF PAVEMENT MARKINGS	314
600.1.14	CONDITION OF ROAD TRAFFIC NOISE MITIGATION	314

600.1.15	CONDITION OF DELINEATORS	314
600.2	BRIDGE STRUCTURES HANDBACK REQUIREMENTS - NEW	
INFRASTRUCTURE		316
600.2.1	GENERAL	316
600.2.2	INDIVIDUAL COMPONENT REQUIREMENTS - BRIDGES	316
600.2.2.1	Concrete Bridge Decks	316
600.2.3	INDIVIDUAL COMPONENT REQUIREMENTS – BRIDGE CULVERT STRUCTURES	317
600.2.4	INDIVIDUAL COMPONENT REQUIREMENTS - SIGN STRUCTURES... ..	317
600.3	ROADWAY HANDBACK REQUIREMENTS - EXISTING	
INFRASTRUCTURE		319
600.3.1	PAVEMENT SURFACE CONDITION	319
600.3.2	CONDITION OF ALL SIGNS	319
600.3.3	CONDITION OF GUARDRAIL	320
600.3.4	CONDITION OF BARRIERS	320
600.3.5	CONDITION OF LIGHTING.....	320
600.3.6	CONDITION OF TRAFFIC SIGNALS	320
600.3.7	CONDITION OF THE DRAINAGE SYSTEM	321
600.3.8	CONDITION OF CONCRETE CURBS, GUTTERS, SIDEWALKS, BARRIERS (NON-STRUCTURE RELATED)	321
600.3.9	CONDITION OF LANDSCAPING.....	321
600.3.10	CONDITION OF FENCING	321
600.3.11	CONDITION OF PAVEMENT MARKINGS.....	322
600.3.12	CONDITION OF DELINEATORS	322
600.4	BRIDGE STRUCTURES HANDBACK REQUIREMENTS - EXISTING	
INFRASTRUCTURE		323

APPENDIX A – DRAWINGS

APPENDIX B - PAYMENT ADJUSTMENT SUMMARY

APPENDIX C – REPORTING SUMMARY

**APPENDIX D - HISTORICAL RESOURCES ACT (ALBERTA) CLEARANCE
LETTER**

APPENDIX E - GUIDE SIGNING FOR NEW INFRASTRUCTURE

APPENDIX F – LIST OF ACRONYMS

**APPENDIX G – ALBERTA INFRASTRUCTURE AND TRANSPORTATION
LAND LEASE SUMMARY AND DRAWINGS**

APPENDIX H – AUTOMATIC TRAFFIC RECORDER (ATR) SPECIFICATIONS

**APPENDIX I - ROAD WEATHER INFORMATION SYSTEM – DRAWING 18-I-
01**

100.0 GENERAL

100.1 INTRODUCTION

References to section numbers in this Schedule are to section numbers of the Technical Requirements unless expressed otherwise.

This Section covers the general technical requirements applicable to all design, construction and operations of the New Infrastructure and the Existing Infrastructure.

The information in the Technical Requirements is organized as follows:

- Section 100 - General;
- Section 200 - Project Specifics;
- Section 300 - Design and Construction - New Infrastructure;
- Section 400 - Operations - New Infrastructure;
- Section 500 - Operations - Existing Infrastructure;
- Section 600 - Handback Requirements;
- Appendix A - Drawings;
- Appendix C – Reporting Summary;
- Appendix D - *Historical Resources Act* (Alberta) Clearance Letter;
- Appendix E - Guide Signing for New Infrastructure;
- Appendix F – List of Acronyms;
- Appendix G – Alberta Infrastructure and Transportation Land Lease Summary and Drawings;
- Appendix H – Automatic Traffic Recorder (ATR) Specifications; and
- Appendix I - Road Weather Information System - Drawing 18-I-01.

In the event of any conflict or inconsistency between the Sections/Appendices, such conflict or inconsistency shall be resolved on the basis of the wording in the higher up in the following list:

- Sections 100.1 and 200, including Appendices A, D, E, F, G, H and I;
- Sections 300, 400, 500 and 600; and
- Section 100.2 and Appendix C.

References to any standards, publications, policies, guidelines or other requirements in the Technical Requirements (the “Standards”), are to the Standards that existed as of the deadline for SR2 (as defined in the Request for Proposals issued by the Department for Northeast Stoney Trail).

100.1.1 DEFINITIONS

In this Schedule 18 (Technical Requirements), capitalized terms shall have the corresponding meaning as set out in Section 1.1 of the DBFO Agreement (as defined below) and the following expressions shall have the following meanings (and where applicable their plurals have corresponding meanings):

“**As-Built Construction Reports**” has the meaning set out in Section 300.3.3;

“**Bare Pavement**” means the travel lanes, and walkway/pathways being free of snow, packed snow, frost or ice;

“**bridge structures**” include bridges, bridge size culverts (1.5 metre diameter or larger), retaining walls, and overhead and cantilevered sign structures that form the Infrastructure;

“**C-D**” means collector-distributor;

“**City**” means The City of Calgary;

“**Contractor’s Engineer**” means a Professional Engineer or engineers that are employed by or retained by the Contractor for the design, construction, operation, and maintenance of the Project and the O&M;

“**DBFO Agreement**” means the Agreement to Design, Build, Finance and Operate Northeast Stoney Trail, Calgary between Her Majesty the Queen in right of Alberta and the Contractor, as defined therein, to which agreement this Schedule 18 (Technical Requirements) is attached;

“**Department**” means the Province, as represented by the Minister of Infrastructure and Transportation. The Department or Alberta Infrastructure and Transportation was formerly known as Alberta Transportation and so references to Alberta Transportation are to the Department;

“**Detailed Designs**” means the plans, specifications and drawings that the Contractor is required to provide pursuant to Section 5.9 of the DBFO Agreement;

“**Existing O&M Payment**” has the meaning as set out in Section 2 of Schedule 14 (Payment Schedule) to the DBFO Agreement;

“**Functional Plan**” means the Calgary East Ring Road Functional Planning Study (Final Report – Volumes 1 to 3) dated April 2006 and prepared by Earth Tech (Canada) Inc.;

“**Infrastructure**” means the New Infrastructure and the Existing Infrastructure;

“**Local Authority**” means the City or the MD, as applicable;

“**MD**” means Municipal District of Rocky View No. 44;

“Ministerial Consent” means the written consent of Alberta Infrastructure and Transportation pursuant to section 5(2) of *Calgary Restricted Development Area Regulations* (AR 212/76, as amended);

“New O&M Payment” has the meaning as set out in Section 2 of Schedule 14 (Payment Schedule) to the DBFO Agreement;

“Professional Engineer” means an individual who holds a certificate of registration to engage in the practice of engineering under the *Engineering, Geological and Geophysical Professions Act*, R.S.A. 2000, c. E-11, or any replacement legislation;

“Province” means Her Majesty the Queen in right of Alberta;

“Reclamation Certificate” means a reclamation certificate for disturbed lands as required by under the *Environmental Protection and Enhancement Act* (Alberta), R.S.A. 2000, c. E-12, or any replacement legislation;

“roadways” include all mainline lanes and shoulders, interchange ramps, crossroads and other roads that form the Infrastructure, as well as the associated drainage systems, lighting, signage, signals, markings, landscaping, fencing and other appurtenances, excluding bridge structures;

“Schedule of Lane Closures” has the meaning as set out in Sections 400.1.6 and 500.1.6;

“Stage 1” means the initial configuration of the New Infrastructure as described in the Functional Plan and as modified and expanded in the Technical Requirements;

“Storm Event” means a period of time of continuous precipitation and/or condensation and/or wind causing the formation of snow and/or ice on the roadway surface;

“Third Party Leased Lands” are those lands as set out in Appendix G (Alberta Infrastructure and Transportation Land Lease Summary and Drawings); and

“Ultimate Stage” means the planned final configuration of the New Infrastructure as described in the Functional Plan and as modified and expanded in the Technical Requirements.

Appendix F contains a list of acronyms frequently used within the Technical Requirements.

Words and abbreviations which are not defined in the Technical Requirements or the DBFO Agreement and which have well known technical or trade meanings and which are used in the Technical Requirements are used in accordance with such recognized meanings.

Standard units of measurement may be abbreviated in the Technical Requirements.

100.2 MANAGEMENT SYSTEMS AND PLANS

Subject to Section 5.5 of the DBFO Agreement, the Contractor shall further develop, implement, and maintain and shall monitor, update, and manage, until the end of the Term, the Contractor's Construction Schedule and the Contractor's Management Systems and Plans to comply with the Technical Requirements.

100.2.1 QUALITY MANAGEMENT SYSTEM

Subject to Section 5.5 of the DBFO Agreement, the Contractor shall further develop, implement, and maintain and shall monitor, update, and manage, until the end of the Term, the Quality Management System (the "QMS"), as attached in Schedule 4 (Contractor's Management Systems and Plans) to the DBFO Agreement.

The QMS shall be consistent with all of the requirements of the *ISO 9001:2000* Standard (and subsequent revisions) and shall cover all activities, products and services related to the Project and the O&M, prior to the execution of these activities, products and services. The Contractor shall make all QMS records available to the Department for inspection and review. The Contractor shall provide the Department with a copy of any or all quality records when requested. The QMS shall address all stages of the Project and the O&M, specifically:

- Design;
- Construction; and
- Operations, including maintenance and rehabilitation.

The QMS shall stipulate how compliance with the Technical Requirements and the Contractor's Management Systems and Plans is ensured. During all stages of the Project and the O&M, work shall not be started on any component of the work until after the QMS has been completed and implemented for that component of the work. All records from the QMS for design, construction, operation, and maintenance, including all audits, shall be maintained and retained by the Contractor until the end of the Term or until otherwise agreed to in writing by the Department.

The individuals responsible for carrying out quality control and quality assurance shall be identified in the QMS.

The QMS shall include, but not be limited to:

100.2.1.1 Design

The QMS shall require all designs, drawings, specifications and similar documents, for all aspects of the Project and the O&M, be stamped and signed by Professional Engineers in accordance with *Association of Professional Engineers, Geologists, and Geophysicists of Alberta (APEGGA) Practice Standard for Authenticating Professional Documents V2.0*.

The QMS shall require two levels of design checks as listed below:

- (a) The QMS shall require all design work be checked by a qualified Professional Engineer (the “Check Engineer”). The Check Engineer may be employed by the same legal entity doing the design work, provided the Check Engineer was not involved in that component of the design work. The Check Engineer shall stamp and sign all applicable design reports, drawings and specifications.
- (b) The QMS shall require all bridge structure design work be reviewed by a qualified, independent Professional Engineer (the “Review Engineer”) selected within 30 days of signing of the DBFO Agreement by the Contractor but approved by the Department, acting reasonably. The Review Engineer shall be employed by a legal entity that is not carrying out any design work for the Project, and that is at arm’s length from and completely independent of the Contractor and any entity carrying out any design or design checking work for the Project. The design review for bridge structures done by the Review Engineer shall include, but not be limited to, the following:
 - o Complete review of the design data drawings including re-analysis of all aspects of the original design including hydrotechnical, geotechnical, geometric and operational safety components;
 - o Complete review and re-analysis of all aspects of the original structural design, preferably (but not essentially) by a methodology other than that used in the original design to ensure that the design parameters are relevant, the structural system is sound and the structural members are appropriately sized and detailed;
 - o Ensuring that the engineering drawings and construction specifications accurately convey the requirements of the original design; and
 - o Ensuring the completeness, integrity and accuracy of all aspects of the engineering drawings and construction specifications.

The Review Engineer shall provide independent design check notes and shall report that the design checks have been completed based on the information provided by the design engineer of record and is satisfied that the designs meet the Technical Requirements.

If a non-conformance in the design is determined at any time, including after construction, the Contractor shall undertake the necessary modifications to ensure the as-built New Infrastructure is in accordance with the Project Requirements.

100.2.1.2 Construction

The QMS shall provide for ensuring that the as-built Project is in conformance with the requirements of the engineering drawings and construction specifications developed for the New Infrastructure. The Contractor shall implement a methodology to verify compliance of the construction with the design requirements. Changes made to the design during construction shall be stamped and signed by Professional Engineers from the design team. At the end of

construction a Professional Engineer from the design team shall be required to stamp and sign a declaration that the New Infrastructure has been constructed in accordance with the engineering drawings and construction specifications.

The Contractor shall make all QMS records available to the Department for inspection and review. The Contractor shall provide the Department with a copy of any or all quality records when requested.

For all construction materials and products, the QMS shall detail the testing and acceptance program, including, but not limited to, the following:

- Material property or characteristics to be measured or inspected;
- Test methods and reference standards;
- Testing frequency;
- Inspection criteria and frequency; and
- Criteria for product acceptance/rejection.

The QMS shall require complete testing/inspection reports be prepared for the Project and the O&M, including all test results and inspection activities for all grade, subbase, base and surfacing materials, bridge structures, curb and gutter, sidewalks, drainage items, lighting, signals, signage, pavement markings, and other appurtenances.

Non-conforming construction works will be considered unacceptable and the Contractor shall undertake the necessary modifications to ensure the as-built New Infrastructure conforms to the requirements of the engineering drawings and construction specifications.

100.2.1.3 Operations

The QMS shall provide for ensuring that the Project and the O&M conform to the Project Requirements and the O&M Requirements respectively, as well as operating consistently with adjoining roadways.

The Contractor shall update annually during the Operating Period, the plans detailing the inspection, operation, maintenance, and New Infrastructure rehabilitation activities that will be conducted during the upcoming year to ensure that all requirements in the DBFO Agreement are met. The plans shall include information on scheduling, traffic management and communications with stakeholders.

Non-conforming inspection, operation, maintenance and rehabilitation will be considered unacceptable and the Contractor shall undertake the necessary modifications to ensure conformance with the Technical Requirements.

100.2.1.4 Audits

100.2.1.4.1 Internal Audit

The Contractor shall undertake QMS Internal Audits, as per *ISO 9001:2000 Element 8.2.2*, during design, construction and operation, through to the end of the Operating Period. The auditor shall follow the guidelines for *Auditing Management Systems, ISO 19011:2002* standard, as amended or substituted from time to time. The audit shall, at a minimum, ensure that all input requirements are adhered to and that the QMS is implemented and in compliance with the requirements of *ISO 9001:2000* standard, as amended or substituted from time to time, customer requirements and applicable regulatory standards. All elements shall be audited at least once per year.

All QMS deficiencies identified by the internal QMS auditor during the audit, must be addressed and corrective measures implemented by the Contractor. The Contractor shall communicate the results of all audits to the Department.

100.2.1.4.2 External Audit

In addition to the internal audits, the Contractor shall undertake QMS external audits during the design, construction and operation through to the end of the Operating Period.

These external audits must be conducted by an independent QMS auditor certified by a known auditors' registration body such as International Register for Certificated Auditors (IRCA), Registrar Accreditation Board (RAB), National Quality Institute (NQI), or other equivalent body. The auditor must also be qualified to audit the scope of the QMS. The audit process shall follow the guidelines for *Auditing Management Systems, ISO 19011:2002*, as amended or substituted from time to time. The audit shall, at a minimum, ensure that all input requirements are adhered to and that the QMS is implemented and in compliance with the requirements of the *ISO 9001:2000* standard, as amended or substituted from time to time, customer requirements and applicable regulatory standards. A full system audit shall be completed within one year of the signing of the DBFO Agreement and thereafter at least once per year until the end of the Operating Period.

All QMS deficiencies identified by the external QMS auditor during the audit shall be addressed and corrective measures implemented by the Contractor within 30 days of completion of the audit. The results of the audit shall be documented and shall be submitted by the Contractor to the Department within seven days of audit completion. Evidence of the correction of any deficiencies identified in the audit shall be submitted by the Contractor to the Department within 30 days of completion of the audit.

If an external audit has not been completed within the specified time, Payment Adjustments of \$2,000/week or any partial week, for the first four weeks and \$5,000/week or any partial week, thereafter shall apply until so completed.

If any deficiencies identified by the external QMS auditor have not been corrected within the specified time, Payment Adjustments of \$5,000/week or any partial week, for the first four weeks and \$10,000/week or any partial week, thereafter shall apply until corrected.

100.2.2 ENVIRONMENTAL MANAGEMENT SYSTEM

Subject to Section 5.5 of the DBFO Agreement, the Contractor shall further develop, implement, and maintain and shall monitor, update, and manage, until the end of the Term, the Environmental Management System (the “EMS”), as attached in Schedule 4 (Contractor’s Management Systems and Plan) to the DBFO Agreement.

The EMS shall be consistent with all of the requirements of the *ISO 14001:2004* Standard and shall cover all activities, products and services related to the Project and the O&M prior to the execution of these activities, products and services. The EMS shall address all stages of the Project and the O&M, specifically:

- Design;
- Construction; and
- Operations, including maintenance and rehabilitation.

The EMS shall stipulate how compliance with all applicable laws and all the requirements in the DBFO Agreement (including without limiting the generality of the foregoing the technical requirements/commitments in the Functional Plan), is ensured. During all stages of the Project and the O&M, work shall not be started on any component of the work until after the EMS has been completed for that component of the work. The EMS shall include, but not necessarily be limited to the following:

100.2.2.1 Monitoring and Inspection Programs

The EMS shall provide for documented environmental monitoring and inspection programs that verify compliance with all the requirements. The documented programs shall include a description of:

- The scoping of the monitoring and/or inspection programs;
- Frequency of inspection and/or monitoring events and rationale for frequency;
- Listing of applicable performance requirement criteria (may include legislative requirements);
- Methodologies;
- Reporting; and
- The responsibilities and requirements for conducting inspections, monitoring programs, reporting results and follow-up actions.

All deficiencies identified must be addressed and corrective and preventative measures implemented by the Contractor.

100.2.2.2 Internal Audit

The Contractor shall undertake internal EMS audits, as per *ISO 14001:2004 Element 4.5.4*, on a regular basis and in any event at least once per year during the design, construction and operation, through to the end of the Operating Period. The auditor shall follow the current guidelines for *Auditing Management Systems, ISO 19011:2002*, as amended or substituted from time to time. The audit shall, at a minimum, ensure that all input requirements are adhered to and that the EMS is implemented and in compliance with the requirements of *ISO 14001:2004* standard, customer requirements and applicable regulatory and other requirements. All elements shall be audited at least once per year.

All internal audit results must be addressed, corrected and implemented by the Contractor.

100.2.2.3 External Audit

In addition to the internal audits, the Contractor shall undertake EMS external audits during design, construction and operations, through to the end of the Operating Period.

These external audits must be conducted by an independent EMS auditor certified by a known auditors' registration body such as RAB, Canadian Environmental Certification Appeals Board (CECAB) or other equivalent body. The auditor must also be qualified to audit the scope of the EMS. The audit process shall follow the current guidelines for *Auditing Management Systems, ISO 19011:2002*, as amended or substituted from time to time. The audit shall, at a minimum, ensure that all the input requirements are adhered to and that the EMS is implemented and in compliance with the requirements of *ISO 14001:2004*, customer requirements and applicable legal and other requirements. A full system audit shall be completed within one year of the signing of the DBFO Agreement and thereafter at least once per year until the end of the Operating Period.

All EMS deficiencies identified by the external EMS auditor during the audit shall be addressed and corrective measures implemented by the Contractor within 30 days of the completion of the audit. The results of the audit shall be documented and shall be submitted by the Contractor to the Department within seven days of audit completion. Evidence of the correction of any deficiencies identified in the audit shall be submitted by the Contractor to the Department within 30 days of completion of the audit.

If an external audit has not been completed within the specified time, Payment Adjustments of \$2,000/week or any partial week, for the first four weeks and \$5,000/week or any partial week, thereafter shall apply until completed.

If any deficiencies identified by the external EMS auditor have not been corrected within the specified time, Payment Adjustments of \$5,000/week or any partial week, for the first four weeks and \$10,000/week or any partial week, thereafter shall apply until corrected.

100.2.3 HANDLING OF QMS/EMS NON-CONFORMANCE

Non-conformance of required outputs may be a deficiency in the characteristics, documentation or procedures that makes the quality of a product, activity or service unacceptable or not according to specified requirements and any other known acceptance criteria.

In all instances, the Contractor shall review and inspect remedial work and sign-off all the non-conformance reports. All remedial work shall be at the Contractor's expense.

The Contractor shall maintain an up-to-date register of all non-conformance reports indicating their current status. If requested by the Department, a copy of all non-conformance reports shall be made available to the Department.

All deficiencies identified during the daily activity, inspections, audits and/or reviews (internal or external) must be addressed, and corrective measures must be implemented by the Contractor. The Contractor shall submit the results of all the corrective actions and disposition of all non-conformities to the Department.

100.2.4 PROJECT SCHEDULE

Subject to Section 5.5 of the DBFO Agreement, the Contractor shall further develop, implement, and maintain and shall monitor, update, and manage, until the end of the Term, the Contractor's Construction Schedule.

During the construction of the Project, the Contractor shall provide the Department with Contractor's Construction Schedules that are sufficiently detailed to give the Department a minimum of two working days advance notice of all significant construction and fabrication activities.

100.2.5 TRAFFIC MANAGEMENT PLAN

Subject to Section 5.5 of the DBFO Agreement, the Contractor shall further develop, implement, and maintain and shall monitor, update, and manage, until the end of the Term, the Traffic Management Plan, as attached in Schedule 4 (Contractor's Management Systems and Plans) to the DBFO Agreement. The Traffic Management Plan for specific components of the Project or the O&M, as applicable, shall be reviewed in accordance with Schedule 5 (Design and Plan Certification and Review Procedure) prior to the start of that component of the Project or the O&M, as applicable.

100.2.6 SAFETY PLAN

Subject to Section 5.5 of the DBFO Agreement, the Contractor shall further develop, implement, and maintain and shall monitor, update, and manage, until the end of the Term, the Safety Plan, as attached in Schedule 4 (Contractor's Management Systems and Plans) to the DBFO Agreement. The Safety Plan for a specific component of the Project or the O&M, as applicable, shall be reviewed in accordance with Schedule 5 (Design and Plan Certification and Review Procedure) prior to the start of that component of the Project or the O&M, as applicable.

100.2.7 PUBLIC COMMUNICATION STRATEGIES

Subject to Section 5.5 of the DBFO Agreement, the Contractor shall further develop, implement, and maintain and shall monitor, update, and manage, until the end of the Term, the Public Communication Strategies, as attached in Schedule 4 (Contractor's Management Systems and Plans) to the DBFO Agreement. The Public Communication Strategies for a specific component of the Project or the O&M, as applicable, shall be reviewed in accordance with Schedule 5 (Design and Plan Certification and Review Procedure) prior to the start of that component of the Project or the O&M, as applicable.

The Contractor shall be responsible for all public communications, which shall include but not be limited to, public presentations and open houses, public advertisements and mail drops, project website development, project phone hotlines, handling public complaints, etc.

Any direct contact the Contractor makes with the media shall be subject to the prior review and approval of the Department. This shall include media releases, interviews, advertisements, etc.

The Contractor shall maintain comprehensive records of all communications activities including documentation of the information presented, the audience, relevant dates, etc.

If the Contractor proposes major deviations from the Functional Plan or approved plans, at anytime after execution of the DBFO Agreement until the end of the Term, and is deemed to be meeting the Technical Requirements, the Contractor shall in any event proceed through a public consultation process to obtain public approval/acceptance of such deviations including undertaking the following:

- define who are the stakeholders;
- develop a communication plan including those stakeholders as participants;
- determine a process and mechanism on how public acceptance is to be determined, measure, and obtained;
- seek and obtain acceptance of the communication plan and approval process from the Department; and
- potentially seek and obtain approval from the Local Authority and meet the Local Authority design standards for the deviation.

100.2.8 CONSTRUCTION MANAGEMENT PLAN

Subject to Section 5.5 of the DBFO Agreement, the Contractor shall further develop, implement, and maintain and shall monitor, update, and manage, until the end of the Term, the Construction Management Plan, as attached in Schedule 4 (Contractor’s Management Systems and Plans) to the DBFO Agreement. The Construction Management Plan for a specific component of the Project or the O&M, as applicable, shall be reviewed in accordance with Schedule 5 (Design and Plan Certification and Review Procedure) prior to the start of that component of the Project or the O&M, as applicable.

100.2.9 OPERATION AND MAINTENANCE PLAN

Subject to Section 5.5 of the DBFO Agreement, the Contractor shall further develop, implement, and maintain and shall monitor, update, and manage, until the end of the Term, the Operation and Maintenance Plan, as attached in Schedule 4 (Contractor’s Management Systems and Plans) to the DBFO Agreement.

The Operation and Maintenance Plan shall be finalized prior to Traffic Availability and with the exception of the snow clearing and ice control portion of the plan (the “Snow Clearing and Ice Control Plan”) and the preferential bridge deck icing control portion of the plan (the “Preferential Bridge Deck Icing Plan”), shall be updated annually prior to the start of each calendar year.

The Snow Clearing and Ice Control Plan and Preferential Bridge Deck Icing Plan shall be updated annually and reviewed in accordance with Schedule 5 (Design and Plan Certification and Review Procedure) prior to September 15 of each year.

Traffic will not be allowed on the New Infrastructure until after the initial Operation and Maintenance Plan has been reviewed in accordance with Schedule 5 (Design and Plan Certification and Review Procedure).

The Contractor shall ensure that it addresses in the Operation and Maintenance Plan all of the components necessary to the safe and efficient operation of the Infrastructure. It may also be necessary for the Contractor to modify its operations to address deficiencies not specifically identified in the Technical Requirements but which are required for the safety of the travelling public or are recognized by the industry as a normal industry practice.

The Preferential Bridge Deck Icing Plan shall be reasonably designed to prevent preferential bridge deck icing from occurring on the PBD Bridges (as defined in Section 200.2.16).

100.2.9.1 Payment Adjustments

If the Contractor fails to develop and provide the Department with an updated Operations and Maintenance Plan (with the exception of the Snow Clearing and Ice Control Plan and

Preferential Bridge Deck Icing Plan) by the start of each calendar year, the Payment Adjustment shall be \$1,000/week or any partial week, until it is submitted.

If the Contractor fails to develop and provide the Department with an updated Snow Clearing and Ice Control Plan and Preferential Bridge Deck Icing Plan by September 15 of each year, the Payment Adjustment shall be \$5,000/week or any partial week, for the first four weeks and then \$10,000/week or any partial week, thereafter until it is submitted.

100.2.10 INFRASTRUCTURE WHOLELIFE MANAGEMENT PLAN

Subject to Section 5.5 of the DBFO Agreement and in accordance with Section 100.2.1.3 (Quality Management System – Operations), the Contractor shall further develop, implement, and maintain and shall monitor, update, and manage, until the end of the Term, the Infrastructure Wholelife Management Plan, as attached in Schedule 4 (Contractor’s Management Systems and Plans) to the DBFO Agreement.

The Infrastructure Wholelife Management Plan shall be reviewed in accordance with Schedule 5 (Design and Plan Certification and Review Procedure) prior to Traffic Availability and shall be updated annually prior to the start of each calendar year.

Traffic will not be allowed on the New Infrastructure until after the initial Infrastructure Wholelife Management Plan has been reviewed in accordance with Schedule 5 (Design and Plan Certification and Review Procedure).

100.2.10.1 Payment Adjustments

If the Contractor fails to develop and provide the Department with an updated Infrastructure Wholelife Management Plan by the start of each calendar year, the Payment Adjustment shall be \$1,000/week or any partial week, until it is submitted.

100.3 DEPARTMENT REVIEW

The Contractor shall make all design, construction and operations documentation relating to the design, construction, operation and performance of the Infrastructure available to the Department for the Department's review, measurement and observation purposes.

200.0 PROJECT SPECIFICS

200.1 INFRASTRUCTURE LIMITS

The Infrastructure limits will vary as the project progresses into different stages and locations. The Infrastructure limits have been set for the following stages:

- New Infrastructure - Design, construction and operations, including maintenance and rehabilitation; and
- Existing Infrastructure - Operations, including maintenance.

200.1.1 NEW INFRASTRUCTURE

The New Infrastructure consists of Northeast Stoney Trail, generally from Highway 2 to Highway 1A and is set out in Schedule 13 (New Infrastructure) attached to the DBFO Agreement.

200.1.1.1 New Infrastructure Limits - Interim Restrictions

As of May 1, 2006, several properties required for the construction of New Infrastructure are still to be purchased (the “To Be Acquired Land”).

Two properties, located on the north side of the south boundary of the TUC at Métis Trail NE will be purchased and the TUC boundary amended to include the properties as shown on Drawing 18-A-02 to provide crossroad right-of-way for Métis Trail. Several other properties are to be purchased to provide rights-of-way on which service roads are to be constructed. These properties are shown on Drawing 18-A-03 (in vicinity of Country Hills Boulevard) and Drawing 18-A-04 for extensions of both 32nd Avenue NE and Memorial Drive E.

Unless otherwise authorized in advance and in writing by the Department, the Contractor shall not enter upon the To Be Acquired Land until the To Be Acquired Land has been transferred to the Department which will be by June 30, 2007.

200.1.2 EXISTING INFRASTRUCTURE

The Existing Infrastructure consists of Northwest Stoney Trail, generally from Highway 2 to Highway 1 and is set out in Schedule 8 (Existing Infrastructure) attached to the DBFO Agreement.

200.2 DESIGN AND CONSTRUCTION OF NEW INFRASTRUCTURE

200.2.1 GENERAL

The Contractor is responsible for the design, construction, operation, maintenance and rehabilitation of the New Infrastructure which includes, but is not limited to, a multi-lane roadway, connecting roadways, crossroads, service roads, interchanges, bridge structures and associated infrastructure.

The requirements of the Department for the New Infrastructure is consistent with staged project delivery of the ultimate functional plan, but for only the Northeast Stoney Trail component.

- The south terminal of the New Infrastructure is 17th Avenue SE, beyond which Stoney Trail will be a future project.
- The west terminal of the New Infrastructure is at Deerfoot Trail where a system interchange has been designed and is partially being constructed by others as Existing Infrastructure. All of the ramps and connectors at the Deerfoot Trail Interchange are to be constructed to the Ultimate Stage in the New Infrastructure program, with only mainline main lanes to be widened ultimately.
- A system interchange at the TransCanada Highway is a requirement of the New Infrastructure, but ultimate base and paving of ramps/connectors for east to south and north to west and south to west movements deferred to a future project. All of the grading for the ultimate interchange is to be performed as part of the New Infrastructure. Paving and bridges for New Infrastructure ramps and connectors will be for the ultimate interchange, with the exception of mainline bridges and lanes that are to be widened to Ultimate Stage as future project(s) outside of this Project.
- A system interchange to allow northward extension of Stoney Trail East (Sec. 36-25-29-4) is not required in the New Infrastructure scope. No grading of ultimate roadways for this interchange beyond the ramp gore points shall be required.
- The design and construction requirements for Stage 1 include interchanges at the following crossroads as part of the New Infrastructure:
 - Métis Trail NE
 - Country Hills Boulevard
 - Airport Road
 - McKnight Boulevard
- No interchange bridge or paving for 60th Street NE crossroad is included in the New Infrastructure, although design and construction of ultimate interchange grading within the TUC is part of the New Infrastructure.
- The interchange at Métis Trail NE is to be constructed to ultimate configuration in Stage 1.
- The Country Hills Boulevard interchange is to be designed and constructed to tie to the existing two-lane crossroad at the east and west TUC boundary, but to be expandable to become a major street. All mainlines, crossroad loops and ramps are to be graded for the ultimate interchange in Stage 1, with bridge and paving to be widened in future project(s).

- The Airport Road interchange will ultimately be a full movement interchange but will only be constructed to accommodate east to south and north to west traffic movements as part of the New Infrastructure in Stage 1. All ultimate grading is included in the New Infrastructure program. Bridge and paving is to be designed and constructed to minimize loss when widening in future project(s).
- The McKnight Boulevard interchange is to be designed and constructed to tie to the existing two-lane rural road at the east TUC boundary and to match the City four-lane road at the west TUC boundary. Grading is to accommodate widening to a freeway-expressway ultimately. Mainlines, crossroads, loops and ramps are to be graded for the ultimate interchange in Stage 1, with bridge and paving to be widened in future project(s).

The design and construction requirements of the Department include several new service roads to replace access roads to gas/oil wells or local roads which are severed by construction of the New Infrastructure. Such new service roads are set out in Section 200.2.3.18 (Service Roads).

The design of all crossroad elements, including ramps and intersections shall be supported by traffic simulation using Synchro/Sim Traffic software for the following service interchanges:

- Métis Trail NE;
- Country Hills Boulevard;
- Airport Trail; and
- McKnight Boulevard.

The simulation shall be performed using the Interchange Simulation File Package provided by the Department for the Contractor's use for developing and evaluating alternatives and for confirmation/validation of designs, as outlined in Section 200.2.3 (Design Specifics). The Interchange Simulation File Package (the "Package") is posted in the Project electronic data room for this purpose and includes both Stage 1 and Ultimate Stage a.m. and p.m. peak hour Synchro/Sim Traffic model files for each interchange.

Specific instructions will be provided in the Package for the following:

- Default Synchro/Sim Traffic Model Parameters – parameters that are fixed and not to be modified in any way by the Contractor;
- Adjustable Synchro/Sim Traffic Model Parameters – parameters that can be modified by the Contractor in searching for design alternatives;
- List of Measures of Effectiveness as well as interchange performance criteria. Alternative designs proposed by the Contractor shall meet these performance criteria;
- Signal Phasing Requirements and Application Notes; and
- Minimum Traffic Signal Timing Requirements and Application Notes.

If the Stage 1 or Ultimate Stage design proposed by the Contractor is different from the interchange configurations shown in the Package, the Contractor shall:

- demonstrate that operation of the Contractor’s Stage 1 will be acceptable under the Stage 1 A.M. and P.M. peak hour period traffic conditions;
- demonstrate that the Contractor’s Stage 1 design is compatible with the Ultimate Stage; and
- verify that the Contractor’s Ultimate Stage design is equivalent to the Ultimate Stage design in the Functional Plan and will operate satisfactorily under the Ultimate Stage A.M. and P.M. peak hour period traffic conditions.

200.2.2 GEOMETRIC DESIGN

The following design guides shall form the basis for the geometric design:

- *Alberta Transportation Highway Geometric Design Guide* and associated *Design Bulletins*;
- *Transportation Association of Canada (TAC) Geometric Design Guide for Canadian Roads*, including *Alberta Transportation Supplements to this Design Guide*;
- *City of Calgary Design and Construction Standards*; and
- Where design criteria are not specified, desirable design criteria shall be utilized, except where minimum design criteria are acceptable to the safety auditor. The use of combinations of inter-related minimum design criteria is not acceptable.

In addition, the design shall meet the following requirements:

- The mainline is to be designed as a high speed, free-flow, fully access controlled facility;
- All interchange ramp exits and entrances are to be located on the right-hand side, and no left-hand exit or entrance ramps will be permitted;
- Only one exit ramp per direction is to be provided at freeway to freeway interchanges, with the exception of 16 Avenue, McKnight Boulevard, and Airport Trail interchanges in the eastbound direction where consecutive exits will be permitted;
- Interchange exit terminals are to provide decision sight distance appropriate to applicable design speed;
- Transition from rural standards to urban standards (curb and gutter), where applicable, is to occur at the urban end of interchange ramps connecting to the crossroads;
- Lane balance shall be provided in Stage 1 and shall be maintained for subsequent staging through to the Ultimate Stage;
- Design Speed:
 - Mainline 110 km/h
 - Collectors - Distributor Road (C-D) 80 km/h

- Directional Ramps (Except as noted below)..... 90 km/h
- Loop Ramp (Except as noted below)..... 50 km/h
- Crossroads - General..... 70 km/h
- Airport Road 80 km/h
- McKnight Boulevard 80 km/h

Deerfoot Trail/Stoney Trail Interchange

The Department has accepted the geometry of the Deerfoot Trail/Stoney Trail interchange and no major deviations will be permitted. Minor changes to the geometry will need to be approved by the Department.

- Deerfoot Trail..... 110 km/h
- Northbound to Westbound Loop 60 km/h
- Westbound Stoney Trail / C-D Road 80 km/h
- Northbound to Eastbound Directional Ramp..... 80 km/h
- Eastbound to Northbound Directional Ramp..... 80 km/h*
- Southbound to Eastbound Directional Ramp..... 80 km/h*

Stoney Trail/16th Avenue Interchange

- 16 Avenue East of Stoney Trail 110 km/h
- 16 Avenue West of Stoney Trail..... 100 km/h
- Westbound to Southbound Loop Ramp..... 45 km/h**
- Eastbound to Northbound Loop Ramp 45 km/h**
- Southbound to Eastbound Directional Ramp..... 80 km/h*
- Northbound to Westbound Directional Ramp 80 km/h*

*Super elevation rates shall accommodate 80 km/h design speed and shall not exceed the super elevation rates shown in Schedule 18 for these ramps. The Department may consider a design speed of 75 km/h with a posted speed of 70 km/h with no reduction in curve radii.

**The radius for each of the WB to SB and EB to NB loop ramps shall not be less than 80 meters.

- Posted Speed: Posted speed shall be 10 km/h less than the design speed.
- Vertical Grades:
 - Mainline 3.0% Max.
 - Directional Ramps and C-D Roads (90 km/h)..... 4.0% Max.
 - Directional Ramps and C-D Roads (80 km/h)..... 4.5% Max.
 - Ramps
 - On Ramps..... 6.0% Max.
 - Off Ramps..... 4.0% Max.
 - Crossroads
 - Interchanges 4.0% Max.
 - Flyovers..... 5.0% Max.
- K Values

The K Values shall meet or exceed the values shown in the following table:

Design Speed (Km/h)	Crest K Factor	SAG K Factor
110	141	78
100	98	63
90	66	51
80	45	40
70	29	31
50	10	15
45	7	12

- Vertical Curves
 - Minimum length of sag and crest vertical curves:
 - On mainline and 16 Avenue 300m
 - On directional ramps and C-D roads (90 km/h)..... 250m
 - On directional ramps and C-D roads (80 km/h)..... 200m
 - Service Roads (Public) (90 km/h)..... 200m
 - Minimum distance between crest and sag vertical Points of Intersection (PI):
 - On mainline and 16 Avenue 500m
 - On directional ramps and C-D roads (90 km/h)..... 400m
 - On directional ramps and C-D roads (80 km/h)..... 300m
 - Service Roads (Public) (90 km/h)..... 300m
- Superelevation (e max):
 - Mainline 0.06 m/m
 - Ramps 0.06 m/m
 - Crossroads..... 0.06 m/m
- Ramp Terminals Along Mainline Freeways and C-D Lanes:
 - Direct taper design as per *Alberta Transportation Highway Geometric Design Guide* for both exit and entrance terminals.
 - The absolute minimum weaving distance on the mainline facility will be 600 m, based on attaining a minimum Level of Service C (as defined in *Alberta Transportation Highway Geometric Design Guide*). In special cases where weaving lengths cannot be attained, consideration will be given to reducing the taper length distances if justified by a detailed weaving analysis.
- Lane Widths:
 - Mainline 3.7 m
 - C-D Road
 - 1 Lane 4.8 m
 - 2 Lanes..... 3.7 m
 - Ramp
 - 1 Lane 4.8 m
 - 2 Lanes..... 3.7 m

- Crossroads (Refer to City of Calgary Standard Drawing Sheet 14 (Divided Major) and Bridge Information Drawings 18-A-15 to 18-A-32, inclusive in Appendix A)
- Directional Ramps
 - 2 lanes 3.7 m
 - 1 lane 4.8 m
- Shoulder Widths:
 - Mainline
 - Inside (4 and 6 Basic Lanes)..... 2.5 m*
 - Inside (8 Basic Lanes) 3.0 m*
 - Outside..... 3.0 m*

* Any shoulder width in Stage 1 on the pavement side to be widened first in future stages must be 3.7m wide except on bridge structures. Note that the last lane to be constructed in the future shall be the inside lane.

 - System Connectors
 - Inside 2.5 m
 - Outside..... 3.0 m
 - Directional Ramps
 - Inside (1 lane) 1.0 m
 - Inside (2 lanes)..... 2.5 m
 - Outside (1 lane) 2.5 m
 - Outside (2 lanes)..... 3.0 m
 - C-D Road
 - Inside (1 Lane)..... 1.0 m
 - Inside (2 Lanes) 2.5 m
 - Outside (1 Lane) 2.5 m
 - Outside (2 Lanes)..... 3.0 m
 - Ramp
 - Inside (1 Lane)..... 1.0 m
 - Inside (2 Lanes) 2.0 m
 - Outside (1 Lane) 2.5 m
 - Outside (2 Lanes)..... 3.0 m
 - Crossroads (Refer to City of Calgary Standard Drawing Sheet 14 (Divided Major Street on 36.0 m ROW (all in Appendix A) and Bridge Information Drawings 18-A-15 to 18-A-32 inclusive, and New Infrastructure Project Scope Drawings 18-A-08 to 18-A-13, inclusive in Appendix A)
- Median:
 - 4 and 6 Basic Lanes 30.6 m
 - 8 Basic Lanes 23.2 m
- Outer Separation
 - C-D Road (1 Lane) (edge of driving lane to edge of driving lane)..... 17.0 m
 - C-D Road (2 Lanes) (edge of driving lane to edge of driving lane)..... 20.0 m
- Bikeways/Pedestrian Walk*:
 - Bikeway/Pedestrian Walk (on grade) 2.5 m to 3.0 m

- Bikeway/Pedestrian Walk on Bridges 4.2 m
- Pedestrian Sidewalk on Bridge (where cyclists have an outer lane shared with motor vehicles 4.3 m wide) 2.5 m
- * Height of bridge parapet/railing on outside of bikeway/pedestrian walk shall be 1.4 m. Bikeway/pedestrian walks on bridge structures shall be separated from the traffic lanes by a parapet/railing.

- Slopes:*
 - Pavement Structure Sideslopes
 - Mainline, System Connectors, and Directional Ramps. 6:1
 - C-D Roads, Ramps, and Crossroads..... 5:1
 - Subgrade Sideslopes
 - Mainline and System Connector
 - Fill 0 - 2.5 m..... 6:1
 - Fill 2.5 - 3.0 m..... Slope Variable, Toe at 15 m Fixed
 - Fill 3.0 - 4.0 m..... 5:1
 - Fill 4.0 - 5.0 m..... Slope Variable, Toe at 20 m Fixed
 - Fill Over 5.0 m..... 4:1
 - C-D Roads and Ramps
 - Fill 0 - 4.0 m..... 5:1
 - Fill 4.0 - 5.0 m..... Slope Variable, Toe at 20 m Fixed
 - Fill Over 5.0 4:1
 - Bridge Approaches
 - 3:1 sideslope acceptable at bridge locations with guardrail and with subgrade to be widened by 1.0 m
 - Bridge Headslopes 2:1 Max.
 - Ditch Backslopes (Top of backslopes to be rounded)
 - Height 0.0 - 3.0 m..... 5:1
 - Height 3.0 - 5.0 m..... Slope Variable, Toe at 15 m Fixed
 - Height Over 5.0 m 3:1
 - Noise Attenuation Berms within the Road Right of Way..... 3:1 Max.
- * All slope ratios are expressed in horizontal:vertical.

- Width of Ditch:*
 - Median 3.0 m Min.
 - Outside 4.0 m Desirable; 3.0 m Min.
 - Ramp, C-D Road - Outside 3.0 m Min.
- * Ditches shall be rounded.

- Vertical Clearances:*
 - Roadway - Underside of superstructure to top of roadway 5.51 m Min.
 - Railway - Underside of superstructure to top of roadway 5.51 m Min.
 - Sign Structures – Roadway surface to underside of sign structure or sign panel, whichever is lower 6.0 m Min.
 - Pedestrian Overpass - Underside of superstructure to top of roadway .5.7 m Min.
 - Roadway - Underside of superstructure to top of rail..... 7.01 m Min.

- Roadway - To High Voltage Power Lines (up to 500 kV) 11.4 m Min.
* Allowance to be made for all future pavement overlays and railway ballast requirements.
- Horizontal Clearances:
 - Edge of shoulder to Bridge Headslope 2.5 m
 - Edge of Ultimate Stage Travel Lane to face of bridge substructure element, retaining walls, existing or relocated power poles and towers, and overhead sign support for structures with two or more vertical supports shall be equal to or greater than the clear zone as specified in TAC *Geometric Design Guide for Canadian Roads*, Section 3.1.3. Use of guardrail/barrier to reduce clear zone dimensions is not acceptable for these elements on Northeast Stoney Trail mainline, Deerfoot Trail mainline, C-D roads, system connectors, directional ramps or loop ramps where the loop ramp cross-section is an extension of the mainline or C-D cross-sections.
 - Edge of Travel Lane to Face of Bridge Parapet or Guardrail
 - Shall meet TAC minimum lateral clearance for stopping sight requirements, but shall not exceed 3.5 m.
 - Back of Guardrail to Solid Object
 - Distance to meet manufacturer's recommendation for design deflection at each design speed.
 - Clear zone calculations for parclo ramps adjacent to bridges shall be based on the directional ramp standard of 90 km/h.
- Stopping Sight Distance:
 - Vertical - Exceed TAC upper value requirements by 25%
 - Horizontal - Meet or exceed TAC SSD upper limits for trucks with conventional braking systems (TAC Table 1.2.5.4)
 - Horizontal – in case of sharp curves at bridge and/or guardrail locations, meet or exceed TAC SSD lower limits with shoulder width not to exceed 3.5 m.
- Horizontal and Vertical Alignments – Mainline:

The Contractor shall design the mainline horizontal and vertical alignment to avoid any perceived roller coaster or kinked curve appearance, and shall ensure that the alignment complements the existing topography.
- Horizontal and Vertical Alignments – Crossroads:
 - Vertical Alignment – K values specified above shall be used
 - Horizontal Alignment approach and departure tapers – follow TAC guidelines in designing approach and departure tapers, with taper ratios calculated based on the upper-range value of the design domain (TAC Section 2.3.8)
 - Transition between 2-Lane / 4-Lane Roadways at Intersections – follow TAC guidelines in designing 2-lane / 4-lane transitions, with the parallel lane length calculated based on the upper-range value of the design domain (TAC Section 2.3.9)
 - Turn Bay Length at Intersection – The length of a Left or Right Turn Bay shall satisfy both deceleration and storage requirements below:
 - Measurement of turn bay length is from the point where the turn bay lane width is 3.0 m to the stopline at the end of the turn bay

▪ Deceleration requirements:

Design Speed of Roadway	Length of Deceleration Lane including Taper, L_d
60 km/h	90 m
70 km/h	110 m
80 km/h	130 m
90 km/h	150 m
100 km/h	170 m

- Storage requirements – to be determined based on results of simulation analysis. The length of the turn bay shall be designed so that either the queue in the through lane will not block the turn bays, or the queue in the turn bays will not spill out of the turn bay and block the adjacent through lane.

- Turn Bay / Taper Length Leading into a Loop Ramp or Free-Flow Right Turn Roadway – The length of a Turn Bay / Taper shall satisfy both deceleration and storage requirements below:

- Measurement of turn bay length is from the point where the turn bay lane width is 3.0 m to the start of the controlling radius of the turning roadway
- Deceleration requirements:

Design Speed of Roadway	Length of Deceleration Lane including Taper, L_d				
	Design Speed of Turning Roadway Curve (km/h)				
	40	45	50	55	60
60 km/h	70 m	65 m	55 m	50 m	n/a
70 km/h	90 m	85 m	75 m	70 m	60 m
80 km/h	105 m	100 m	95 m	90 m	80 m
90 km/h	125 m	120 m	115 m	110 m	100 m
100 km/h	145 m	140 m	135 m	130 m	120 m

- Storage requirements – to be determined based on results of simulation analysis. The length of the turn bay shall be designed so that either the queue in the through lane will not block the turn bays, or the queue in the turn bays will not spill out of the turn bay and block the adjacent through lane.

- Curves shall be introduced at all through-lane deflections in the vicinity of ramp intersections along crossroads (deflections exceeding one degree). Curves shall be long enough to avoid the appearance of a kink but not so long as to require superelevation.

• Number of Ramp Approach Lanes at Intersection:

- For crossroads with cross-section of 4 lanes or more, the ramp intersection approach shall have 2 lanes to permit double left turn movements from the ramp.

• Medians

- The Contractor shall design the roadway to ensure median barriers are not required on the mainline. Medians on crossroads shall be raised type.
- All bridge piers located in the medians of 16 Avenue, Stoney Trail and Deerfoot Trail shall be centered in the median.

- Intersections

At-grade intersections shall be designed to accommodate a Turnpike Double design vehicle except for the design of the Service Roads intersections, in which case the WB21 shall be the design vehicle. Intersection design shall use *desirable* standards from design guides and bulletins as an absolute minimum.

200.2.3 DESIGN SPECIFICS

Additional location specific guidelines have been developed to provide additional directions for Stage 1 construction. These guidelines are intended to ensure specific key elements are addressed in the New Infrastructure.

200.2.3.1 City of Calgary Responsibility

The City is responsible for the design and construction of all roadway connections of the crossroads that are outside of the TUC. The Contractor shall be responsible for the coordination of the design requirements and construction phasing with the City. The Contractor is also responsible for removal, and coordination of any required road removals and closures in the TUC with the City.

200.2.3.2 Intentionally deleted

200.2.3.3 Roadway Mainline

Stage 1 construction shall include Ultimate Stage subgrade for the mainline and auxiliary lanes, bridge structure fills, and associated loops and ramps, unless noted otherwise in this Section 200.2.3. Stage 1 paving shall include lane configuration as shown on Drawings 18-A-08 to 18-A-13 inclusive in Appendix A.

200.2.3.4 Crossroads

Roadways crossing Northeast Stoney Trail shall be designed and constructed to be consistent with the City roadway standards for the Calgary Transportation System Bylaw network. The New Infrastructure shall include crossroads to the edge of the TUC. Crossroads shall be constructed to the TUC boundary where shown on Drawings 18-A-02, 18-A-03 and 18-A-04 in Appendix A. Crossroads to be constructed in Stage 1 are:

- Métis Trail NE;
- Country Hills Boulevard NE;

- Airport Trail (west side connection); and
- McKnight Boulevard.

All crossroads shall be graded to Ultimate Stage and paved to Stage 1 configuration unless noted otherwise in this Section 200.2.3.

The Contractor shall consult with and coordinate its work with the City and the MD, as appropriate, regarding timing and tie-ins of the crossroads at the boundaries of the TUC.

City of Calgary Standard Drawing Sheet 14 included in Appendix A shows requirements for major arterial roadways. Sidewalk requirements shall be as shown on the bridge cross-sections for individual crossroads (i.e. one side only). Sidewalks off bridge structures shall extend to the edge of the TUC in the location shown on the Bridge Information Drawings 18-A-15 to 18-A-32 inclusive in Appendix A.

Para curb ramps shall be constructed at all pedestrian crossings. These ramps shall be in accordance with the standards required by the City for the design and construction of roads within the City.

Approach nose treatments for islands and medians shall be in accordance with the standards required by the City for the design and construction of roads within the City.

200.2.3.5 Bridge Sections

Bridge Information Drawings 18-A-15 to 18-A-32 inclusive in Appendix A, show required elevation, profiles, cross-section, lane, shoulder and walkway configurations, and plan view for Stage 1 and Ultimate Stage, for all New Infrastructure bridge structures .

200.2.3.6 Deerfoot Trail/Stoney Trail Interchange

Some elements of the interchange at Deerfoot Trail/Stoney Trail have been designed and construction is underway as part of the Existing Infrastructure. Specifically, these elements are:

- Barlow Trail detour construction;
- Bridge construction for Deerfoot Trail (realigned to shift Deerfoot Trail roadways eastward); and
- Grading and drainage for some roadways and ramps west of Deerfoot Trail.

The Deerfoot Trail/Stoney Trail interchange site is to be shared by the contractors responsible for the Existing Infrastructure and the Contractor. Project limits for each contract are identified on Drawing 18-A-01 in Appendix A.

- Grading and Drainage

The required horizontal and vertical geometry of this interchange and cross-sections are set out in the Functional Plan. No changes to the geometry at this interchange will be permitted during design of the New Infrastructure, except minor changes required by design detailing.

All grading and drainage for New Infrastructure shall convey runoff to locations established, and in regulated quantities as established by the Northwest Stoney Trail design. Runoff from this interchange outfalls to Nose Creek through facilities designed and constructed in the Northwest Stoney Trail project. The Contractor shall be responsible for complying with Northwest design criteria and for design of bridge structure drainage connections including special requirements to collect and dispose of anti-icing chemicals if needed. All grading shall be constructed to Ultimate Stage.

- Paving

The Contractor shall design and construct pavement structures in the New Infrastructure to tie to the Existing Infrastructure at all project limits shown on Drawing 18-A-01 in Appendix A. In the event that the pavement structure for the New Infrastructure differs from that of the Existing Infrastructure, grading surfaces shall be transitioned to match seamlessly at project limits.

- Retaining Structures

The Contractor is responsible for all retaining structures necessary for grading of all New Infrastructure within the project limits, including those associated with the Contractor's bridge design.

- Bridges

All bridge structures at this interchange shall be designed and constructed to Ultimate Stage. New Infrastructure bridges at this interchange include:

- SB-EB Structures:
 - over WB-SB loop
 - over Deerfoot Trail NB and SB
- EB-NB Structures:
 - over NB and SB Deerfoot Trail
 - over Stoney Trail EB and SB-EB directional ramp
 - over WB Stoney Trail and C-D road.

- Hazard Protection

The Contractor is responsible for the design and construction of all required hazard protection for the Contractor's constructed roadway and bridge structure elements.

- Signage

The Contractor is responsible for the design, supply, and installation of all required signage for the Contractor's constructed roadway and bridge structure elements. Note that some overhead sign bridge structures will be installed by others for the Existing Infrastructure. This may require the Contractor to design and install sign panels on sign structures designed and constructed by others, or to design and construct sign structures to accommodate sign panels designed and erected by others.

- **Roadway Lighting**
The Contractor is responsible for design and installation of all required roadway lighting for the Contractor’s constructed roadway and bridge structure elements.
- **Pavement Markings**
The Contractor is responsible for design and construction of all required pavement markings for the New Infrastructure roadway and bridge structure elements.
- **Fencing**
The Contractor shall install fences to enclose New Infrastructure roads and drainage ponds between Deerfoot Trail and 17th Avenue SE. Fencing west of Deerfoot Trail will be completed by others.
- **Schedule**
The East approach fill construction for the EB-NB directional ramp bridge over Deerfoot Trail must be coordinated with removal of the Barlow Trail detour by the applicable Northwest Stoney Trail contractor. The diversion of Barlow trail traffic to 36 Street is the responsibility of the Contractor prior to the removal of the Barlow Trail detour constructed by the Northwest Stoney Trail contractor. A minimum of 90 days notice shall be provided to both the City and the MD prior to diversion of Barlow Trail traffic.

Project limits for Northeast Stoney Trail project shall be:

- SB-EB Station 60+287
- EB-NB Station 80+366
- NB-EB Station 10+060
- EB Mainline Station 133+080
- WB Mainline Station 232+980
- NB-WB Station 21+162
- WB-NB Station 31+320
- WB C-D Road 35+650

200.2.3.7 36th Street NE

This rural road must remain in service until the Métis Trail NE interchange is opened to traffic. The Contractor is advised that traffic on 36th Street NE will increase due to diversion of Barlow Trail traffic to 36th Street NE by the applicable Northwest Stoney Trail contractor, to facilitate completion of the Existing Infrastructure at Deerfoot Trail/Stoney Trail Interchange.

The Contractor shall coordinate and realign 36th Street NE to connect to Métis Trail NE as a two-lane gravel surface service road prior to closure of 36th Street NE. Alignment of the two-lane road shall be in accordance with Drawing 18-A-08 in Appendix A and cross-section in accordance with Drawing 18-A-14 in Appendix A.

200.2.3.8 Métis Trail NE Interchange

- **Grading**
All grading for Ultimate Stage roadways is to be performed within the project limits in Stage 1. Stage 1 construction will extend to 144th Avenue NE, terminating as a Tee Intersection. Métis Trail, south of the TUC will be constructed by the City at an unscheduled date. At that time, the connector road from 36th Street NE to Métis Trail NE shall be disconnected at the TUC boundary on 36th Street NE and at Métis Trail NE and the service road within the TUC obliterated and the surface restored by the Contractor.
- **Drainage**
Runoff to Nose Creek watershed shall be regulated to not exceed 1.257 l/s/ha (City of Calgary, Water Resources).
- **Traffic**
Synchro Traffic Simulation analysis shall be performed for ultimate conditions which include connection of Métis Trail southward by the City and northward into the MD beyond 144th Avenue. The Synchro model and all assumptions, inputs and conditions provided by the Department shall be used by the Contractor for this analysis.
- **Paving**
Métis Trail shall be paved to meet the requirements of the Synchro analysis with the number of lanes as shown on Drawing 18-A-08 in Appendix A.
- Bridge requirements are shown on Drawing 18-A-20 in Appendix A.
- Traffic signals shall be operating on opening day at both at-grade intersections at this interchange.
- There will be no sidewalk required across the TUC at this Interchange in either Stage 1 or Ultimate Stage.
- Both the east and west bridge barriers shall be combination traffic/bicycle barriers with a minimum height of 1.4 metres.

200.2.3.9 60th Street NE Interchange

The Contractor shall complete the Ultimate Stage grading and drainage of this interchange in Stage 1. No paving or bridge shall be constructed at this location in Stage 1. All graded surfaces shall be top soiled and seeded in accordance with Section 200.2.9 (Topsoil and Seeding). The location and configuration of the Ultimate interchange at this location, as described in the Functional Plan, has been chosen to provide acceptable weaving distances to adjacent

interchanges. Any changes to either the location or configuration of the 60th Street NE Interchange or the Métis Trail NE Interchange which would adversely affect the weaving distances or operations would require analysis by Synchro Traffic Simulation.

An Ultimate Stage interchange design submission will be required to support the grading design. The Ultimate Stage interchange design submission shall include bridge Design Data drawings as defined in Appendix J1 of the Department's *Engineering Consultant Guidelines for Highway and Bridge Projects*.

If the northern grading limits of 60 Street conflict with the Service Road access to be constructed to the well site, the Contractor shall stockpile the remaining fill material required to complete the grading in the immediate vicinity of the practical construction limit. The stockpile shall be constructed in dimensions reasonable for future construction access. The stockpile shall be top soiled and seeded.

200.2.3.10 Future System Interchange in Sec 36-25-29-4

No grading for a future interchange at this location shall be required in Stage 1 beyond that required for Ultimate Stage lanes of Stoney Trail (widening on median side).

200.2.3.11 Country Hills Boulevard Interchange

Stage 1 at this location consists of:

- Country Hills Boulevard is a future major street in the City network, but as of May 1, 2006 exists as a rural two-lane road. The Contractor shall construct an interchange in Stage 1 with ramps tied in to the existing road by the TUC boundaries. Grading and drainage shall be constructed for the Ultimate Stage interchange shown in the Functional Plan. Stage 1 laning will be as shown on Drawing 18-A-10 in Appendix A. Synchro Traffic Simulation analysis must be conducted by the Contractor to confirm Stage 1 and Ultimate laning, and geometry. The Stage 1 road shall be paved, urban standard. Country Hills Boulevard has been designated as a high load corridor and therefore the Contractor shall ensure that all installations at this interchange accommodate load heights as high as 9.14m. Traffic signals shall be installed when warranted or five years prior to the end of the Term, whichever occurs first.

The completion of the new 84th Street NE service road connection to Country Hills Boulevard must be completed and open prior to the removal of the existing 84th Street NE and Country Hills Boulevard intersection.

The south bridge barrier shall be a combination traffic/bicycle barrier with a minimum height of 1.4 metres.

200.2.3.12 Airport Trail NE Interchange

Ultimately, the Airport Trail Interchange will connect to a major City road for access to the Calgary International Airport. Initially, in Stage 1, only partial movements are to be constructed, for north to west and return movements (no east leg) at a jug handle interchange. The grading and drainage shall be completed in Stage 1 at this location for the Ultimate full movement interchange. Traffic simulation modelling for Stage 1 and Ultimate Stage interchanges is required if alternative Ultimate Stage interchange configurations are proposed for review by the Department to assess the impact of the proposal on ultimate traffic operations. Four lanes will be paved in Stage 1 to the west TUC boundary. No sidewalk is required in Stage 1. Lighting shall be designed with provision for conversion for the Ultimate Stage interchange.

200.2.3.13 McKnight Boulevard Interchange

All grading for the Parclo Interchange is to be performed in Stage 1 at this location. Stage 1 paving and bridge will be for a diamond interchange. In the Ultimate Stage, the bridge is to be widened on the south side and loop ramps added in the northwest and southeast quadrants to convert to a Parclo A4 Interchange. Parclo A2 or Parclo B2 Interchange configurations are not acceptable to the Department at this location.

All grading and drainage for the Ultimate Interchange is to be performed in Stage 1, to meet requirements determined by Synchro Traffic Simulation. Stage 1 paving shall conform to the laning identified on Drawing 18-A-12 in Appendix A. Stage 1 bridge shall be as shown on Drawing 18-A-23 in Appendix A.

The Service Road on 100th Street NE from McKnight Boulevard to Country Hills Boulevard must be completed and open prior to the removal of the existing 84th Street NE and McKnight Boulevard intersection.

Traffic signals shall be operating on opening day at both at-grade intersections at this interchange.

The south bridge barrier shall be a combination traffic/bicycle barrier with a minimum height of 1.4 metres.

200.2.3.14 16th Avenue/Stoney Trail Interchange

Stage 1 consists of all grading and all Stage 1 bridges for the Ultimate Stage interchange. No paving of the NB to WB directional ramp or return movement (EB to SB) or SB to WB ramp will be constructed until the traffic signals are removed at 68th Street NE at 16th Avenue NE by the City and freeflow is available in the E-W direction.

In Stage 1, the Contractor shall construct two lanes in each direction on 16th Avenue, and two lanes in each direction along Stoney Trail. Two-lane directional ramps are required for both SB

to EB and NB to WB traffic movements. The two lanes of the SB to EB ramp may be tapered to one lane, in advance of the terminus with the NB to EB ramp, commencing east of the future NB to WB directional ramp structure. The SB/NB to EB entrance ramp terminal shall be constructed as a parallel lane entrance with merge and taper lengths conforming to *Transportation Association of Canada (TAC) Geometric Design Guide for Canadian Roads*, including *Alberta Transportation Supplements* to this TAC Design Guide and *Alberta Transportation Highway Geometric Design Guide* associated *Design Bulletins*. The parallel lane shall be carried across the EB CN Railway structure and tapered out beyond the structure. Successive entrance ramp terminals for SB to EB and NB to EB shall conform to *TAC Geometric Design Guide for Canadian Roads* (Figure 2.4.6.5) to provide appropriate acceleration and merge lengths between successive gore points. Single lane ramps and loops are required for all other elements except EB to SB, which shall be two lanes. Stoney Trail main lane bridges shall be constructed with three lanes in each direction. Stage 1 paving shall conform with Drawing 18-A-13 in Appendix A.

The Contractor shall as set out in the Functional Plan and Technical Requirements construct base and pavement and all lighting, signing and markings required on NB to WB and EB to SB and SB to WB ramps (the “Future 16 Avenue Construction”) no later than the earlier of (the “Future 16 Avenue Construction Deadline”) the following:

- the date the City completes construction of an interchange at 68th Street NE and removes the signals; or
- October 15, 2017.

If the Contractor fails to complete the Future 16 Avenue Construction on or before the Future 16 Avenue Construction Deadline, the Payment Adjustments set out in Section 400.1.6 (Lane Closure) shall apply as if the Future 16 Avenue Construction had been completed but the would be constructed lanes were subject to a Lane Closure (as defined in Section 400.1.6) for 24 hours per day. The foregoing Payment Adjustments shall continue to accrue and be payable until such time as the Contractor completes the Future 16 Avenue Construction.

Prior to removal of the 16th Avenue NE and 84th Street NE intersection, the following roads must be completed and open to traffic:

- 32nd Street NE from 84th Street NE to 100th Street NE;
- Memorial Drive from 84th Street NE to 100th Street NE;
- Emergency access from 16th Avenue NE onto 84th Street NE; and
- Emergency access gate(s) shall be provided to allow access for emergency vehicles from the northbound to eastbound ramp and from eastbound 16 Avenue to 84 Street. Return movements for the emergency vehicles shall be southbound along 84 Street to 17 Avenue. Gates shall conform to City of Calgary standards. Refer to City of Calgary – Standard Emergency Vehicle Gate for Roads Sheet 93. Details of the emergency access can be found on Drawing 18-A-13 in Appendix A. The emergency access gate shall conform to The City of Calgary’s *Standard Emergency Vehicle Gate for Roads*.

200.2.3.15 Stoney Trail Grade Separating Bridges over CN

Twin 4-lane bridges carrying Northeast Stoney Trail over CN Railway shall be constructed in Stage 1. In the Ultimate Stage, each of these structures will be widened one lane (on median side). Clearance envelope shall conform with CN requirements for single track railway.

200.2.3.16 17th Avenue SE

17 Avenue SE is the south terminal of the New Infrastructure. The Stoney Trail mainlines shall be combined to a single approach roadway in Stage 1 at 17 Avenue, as shown on Drawing 18-A-33 in Appendix A. No Ultimate Stage grading for the 17 Avenue SE Interchange is to be performed in Stage 1.

17 Avenue SE shall be widened to a four lane undivided cross-section from the east TUC boundary to the point where the roadway connects to the City roadway near the west TUC boundary. Turn lanes shall be constructed at both the intersection at Stoney Trail and at the intersection at 84 Street SE. Turn lane dimensions at each intersection shall comply with that shown on Drawing 18-A-33. The cross-section of 17 Avenue shall be adapted to meet the City's Four-Lane Major Street cross-section as constructed by the City in conjunction with construction of an intersection at 70 Street NE near the west TUC boundary. The Contractor shall also construct intersection improvements at the intersection of 17 Avenue and 84 Street, including additional lanes both north and south of 17 Avenue.

The Contractor shall design and install traffic signals at the intersection of 17 Avenue and Stoney Trail and at the intersection of 17 Avenue and 84 Street. All existing traffic signal components and equipment shall be removed from the 84 Street location and shall be returned to the City. The new traffic signal installation at Stoney Trail and the replacement traffic signals at 84 Street shall be coordinated with the City and all equipment shall be compatible with City signal equipment and specifications. All new signal components required for this modification shall be supplied and installed by the Contractor.

The signals at 84 Street and at 17 Avenue shall be coordinated between each other and with signals west of Stoney Trail in consultation with the City.

Traffic signals at 17 Avenue SE and Stoney Trail intersection shall provide signal phases for SB, WB and EB traffic as well as “protected only” left turn phase for EB left turns. Advance warning indicators are required for the southbound approach to this intersection.

Traffic signals at 17 Avenue and 84 Street intersection shall provide signal phases for each approach direction, as well as “protected only” left turn phases for NB left turn and SB left turn, and “protected-permissive” left turns for WB left turns and EB left turns. Advance warning indicators are required for the westbound approach to this intersection.

The pavement on 17 Avenue shall be widened with ACP pavement structure consisting of 140mm of ACP (HI with 150-200 A binder) 300mm of D2C20 GBC matched to the existing 280mm to 350mm Full Depth ACP.

The widening of 17 Avenue and associated improvements on 84 Street are not components of either the New Infrastructure or the Existing Infrastructure; rather they shall be subject to the same handback and warranty requirements as the Service Roads. The Contractor shall operate and maintain the signals at Stoney Trail and at 84 Street until Stoney Trail is extended south of 17 Avenue SE.

200.2.3.17 Highway 1 (Trans Canada Highway) Bridges over CN Railway

The eastbound Highway 1 bridge over CN Railway east of Northeast Stoney Trail will require widening to the outside to accommodate an additional 3.7 metre wide lane. The westbound Highway 1 bridge at this location may also require widening in order to meet the design speed requirements for the 16 Avenue NE and Stoney Trail Interchange. Trans Canada Highway traffic must be maintained at all times. Detours shall be a minimum of three lanes, with two lanes available in the peak direction (reversing lane/signal controlled arrangement). Detour lane widths shall be a minimum of 3.5 metres; shoulder widths shall be a minimum of 0.8 metre.

Both the existing and new portions of the bridges will be considered to be Existing Infrastructure for the purposes of operations, maintenance and holdback. The Contractor shall however warranty for two years all new construction and rehabilitation carried out on the bridges.

The following exceptions to Section 300.5.2.7 (Durability) will be allowed for future widening of the existing bridges:

- the bridge superstructure need not be continuous for live load over the piers; and
- the widened bridge deck shall be protected from de-icing salts with a Class HPC with Steel Fibres concrete overlay.

The following exception to Section 300.5.2.4 (Geotechnical) will be allowed for future widening of the existing bridges:

- the east abutments need not be supported on pile foundations.

Regardless of whether or not widening is undertaken, the following rehabilitation measures shall be taken on both the eastbound and westbound structures:

- replacement of the existing deck joints at the piers and abutments with new Type 1 strip seal deck joints as shown on the Department's Standard Drawing S-1626-98 published on the Department's website;
- replacement of the existing asphalt wearing surface and polymer membrane with a Class HPC with Steel Fibres concrete overlay;

- application of silane sealer to existing concrete surfaces in accordance with Section 300.5.7.17 (Sealer); and
- placement of crash protection walls meeting CN Railway requirements on both the existing and widened portions of the piers.

200.2.3.18 Service Roads

In some locations, access to properties and/or businesses will be severed by construction of the New Infrastructure and associated road closures. All access road replacement required shall be included in the Project. Design and construction shall be the responsibility of the Contractor. The Contractor shall design and construct the following new service/access roads as detailed on Drawings 18-A-08 to 18-A-13 (paved or gravel as indicated below):

- A paved connector of 84 Street NE east of the TUC to reconnect the road closure on the south side of Country Hills Boulevard*;
- A paved connector road along 100 Street NE from 200 metres north of Country Hills Boulevard to McKnight Boulevard. The right-of-way for this connector road is 28.0m, including a widening of 8.0m along the west side of the existing road allowance*;
- A paved connector road from 84 Street NE to 100 Street NE along 32 Avenue NE. The right-of-way for this service road is 36.0m*;
- A paved connector road from 84 Street NE to 100 Street NE along Memorial Drive. The right-of-way for this service road is 36.0m*;
- A gravel connector of 84 Street NE east of the TUC to reconnect the road closures on the north side of Country Hills Boulevard*;
- A gravel connector road from 36 Street NE to Métis Trail NE along the south edge of the TUC*;
- A gravel gas well access road from 52 Street NE to the gas well sough of the TUC adjacent to the Métis Trail NE**;
- A replacement gravel access road to reconnect to a gas well located north of the TUC and east of the fill for the future 60 Street NE interchange**;
- A replacement gravel access road to a gas well located south of McKnight Boulevard in the TUC from 84 Street SE**.

* Public Road

** Private Road

Grading and paving shall comply with the cross section for Paved Service Roads (Public) shown on Drawing 18-A-14 in Appendix A. All of the Service Roads shall be designed and constructed to standards identified on the Typical Cross-Section Drawing No. 18-A-14 in Appendix A. Design speed shall be 90 km/h for the public roads and 50 km/h for the private access roads to gas wells. The Contractor is responsible for coordination of design requirements and construction phasing with the MD for the applicable Service Roads.

The Contractor shall construct up to two field approaches with culverts per quarter section on those Service Roads designated as Public Roads above. Specific locations for the field

approaches shall be identified by the Department by June 30, 2007. Field approaches shall satisfy the *Municipal District of Rocky View No. 44 Servicing Standards – Section 400 Road Design Guidelines*, excepting that the surface width of all single approaches shall be 6.1 metres.

No existing road shall be taken out of service until its replacement Service Road has been completed and concurrently opened to traffic. The Contractor is also responsible for removal, and coordination of any required road removals and closures in the TUC with the MD. The Contractor is responsible for all necessary signing for the Service Roads. The Local Authority or oil/gas company, as applicable, is responsible for operating and maintaining the Service Roads from the time of opening to the public (or oil company as applicable) for use by vehicular traffic. Section 5.18 of the DBFO Agreement deals with the Service Roads.

200.2.3.19 Intentionally Deleted

200.2.3.20 Road Closures

The Contractor shall be responsible for the physical closure of existing roads at locations shown on Drawings 18-A-08 to 18-A-13 inclusive in Appendix A.

The Contractor is responsible for all permits and approvals for the physical road closures and removals, construction of the required turnarounds, installation of appropriate signing regarding “no exit”, installation of barricades and disposal of all materials and restoration of the closed road to a natural landscaped area. The roadway structure shall be removed then top soiled and seeded in accordance with Section 200.2.9 (Topsoil and Seeding).

The Contractor is responsible for coordination of all removals and closures with the relevant Local Authority. The Department will be responsible for obtaining legal road closure and the Contractor shall cooperate with the Department in the supply of information for legal road closure.

Design vehicle for turnarounds shall be B-12 (as defined in the *Alberta Transportation Highway Geometric Design Guide*).

200.2.3.21 Closure of Highway 1 & 84 Street NE Intersection and Signalization of Highway 1 & 100 Street NE Intersection

Prior to the closure of 84 Street NE at Highway 1, new traffic signals shall be installed at the Highway 1 & 100 Street NE intersection. Requirements for the new traffic signals are:

- (a) Traffic signals shall be installed in accordance with Section 300.4.1.9.2;
- (b) The signals shall be fully actuated with video detection for all traffic movements. Video detection camera used shall be compatible with The City of Calgary standards;

- (c) The design vehicle shall be the turnpike-double;
- (d) Advance warning signals and the associated speed reduction zones are required for both eastbound and westbound traffic movements. Posted speeds for these speed reduction zones on Highway 1 shall be 70 km/h. A Ministerial Order is required to implement this reduced speed zone on Highway 1, therefore six weeks prior to closure of 84 Street, the Contractor shall provide written notice to the Department advising of the request for the speed reduction. The request shall include a scaled drawing showing the intersection details, advanced warning signals, beginning and end points of speed zones, and any other details relevant to describing this newly signalized intersection. The Department will finalize the Ministerial Order. The signals shall not be put into operation until the Ministerial Order has been issued;
- (e) Slotted left turn lanes shall be constructed for eastbound-to-northbound and westbound-to-southbound traffic movements. The traffic signal shall be designed in such a way to accommodate slotted left turn bays;
- (f) Protected left turn signal phases are required for the westbound and eastbound left turn movements;
- (g) Illumination at this intersection shall be in accordance with Section 200.2.6 (Roadway Lighting); and
- (h) The Contractor is advised that 100 Street may become an alternate high load corridor and therefore shall ensure that all installations at this intersection accommodate load heights as high as 9.14m.

The Contractor shall conduct representative traffic counts at the Highway 1 & 100 Street intersection immediately after the 84 Street closure and undertake all necessary adjustments to the signal timing based on this traffic data for proper operation of this intersection. The Contractor shall undertake continued monitoring of traffic, particularly upon Traffic Availability, and implement further adjustments to the signal timing as required.

Signal hardware salvaged from the Highway 1 & 84 Street intersection belongs to the City and therefore shall not be transferred to other parts of the Project. The Contractor shall coordinate the removal of these signals and their return to the City in accordance with Section 200.2.3.20 (Road Closures).

All improvements undertaken by the Contractor for the Highway 1 & 100 Street NE intersection, including but not limited to the additional turning lanes and signal hardware, shall form part of the New Infrastructure.

200.2.3.22 Intentionally Deleted

200.2.3.23 Detours

The Contractor is responsible for maintaining existing traffic and access on all roadways and for all properties affected by the construction.

Detours for all crossroads, if required, shall maintain safe passage of traffic, and shall allow for one open lane in each direction at all times. All such detours must be constructed with a surface type equal to or better than the surface on the connecting roadways on either end of the detour, and shall have a minimum design speed of 60 km/hr and posted at 50 km/hr. Specified detours are as follows:

- Country Hills Boulevard minimum of one lane in each direction shall have a minimum design speed of 70 km/hr and posted at 60 km/hr.
- McKnight Boulevard minimum of one lane in each direction and shall have a minimum design speed of 70 km/hr and posted at 60 km/hr.
- 16th Avenue NE shall be a minimum two lanes of traffic in both directions and have a minimum design speed of 80 km/hr and posted at 70 km/hr. The detour at the CNR bridges east of 16th Avenue NE shall be as stated in Section 200.2.3.17.
- Deerfoot Trail shall have a minimum of two lanes in either direction and have a minimum design speed of 80 km/h and posted at 70 km/h.

The Department may permit short term local detours to reroute traffic at crossroads or system interchanges at Deerfoot Trail/Northeast Stoney Trail and at 16 Avenue/Northeast Stoney Trail to accommodate construction operations such as girder erection. Prior to the implementation of short term local detours the Contractor shall submit to the Department for review a detailed detour plan and, pursuant to Section 11.2.5 (Traffic Management Plan), an updated Traffic Management Plan identifying the number of lanes, all horizontal and vertical detour geometry, anticipated traffic volumes relative to peak traffic volumes, traffic management and traffic control devices, and hours of operation. A single lane detour may be used for short term, local detours wherever the traffic can be safely accommodated on a single lane. The Contractor shall notify the Local Authority and emergency service providers a minimum of one week prior to all proposed short term traffic interruptions. Short term detours shall be limited to the hours of 10:00 pm to 6:00 am local time.

The City will perform winter maintenance (snow and ice control) of crossroads and detours during the Construction Period. The Department has no agreement with the City to perform summer operation and maintenance for the cross roads or detours. Summer operation and maintenance shall be the Contractor's responsibility.

Section 400.1.5 (Imminent Danger Repairs) shall apply to all detours as if all detours were New Infrastructure. Lane Closure Payment Adjustments as set out below in Sections 400.1.6 (Lane Closure) shall be applied to any reduction of the minimum lane requirements for detours. Detours shall be designed to accommodate the anticipated traffic and to meet the requirements of the Isolated Deficiency Column of Section 400.4.4 (Rutting Performance Requirement) and Section 400.4.6 (General Pavement Maintenance Requirements). The localized roughness maximum allowable will be twice the amount listed in Section 400.4.6 (General Pavement

Maintenance Requirements). The Payment Adjustments as set out in Sections 400.4.4 (Rutting Performance Requirement) and 400.4.6 (General Pavement Maintenance Requirements) shall apply to all detours.

200.2.3.24 Demolition

The Contractor shall demolish, remove and dispose (the “Demolition”) of all buildings, associated works (wells, poles, etc.), other structures or installations located on the Affected Areas (as defined below). The Contractor shall obtain all required permits and approvals for the Demolition. The Contractor shall restore the Affected Areas after the Demolition to a landscaped state consistent with the surrounding area. Burial of the demolition materials shall not be allowed. The “Affected Areas” means those lease areas with File #916G and 926P as set out in Appendix G (Alberta Infrastructure and Transportation Land Lease Summary and Drawings).

200.2.4 MISCELLANEOUS DESIGN REQUIREMENTS

The Contractor shall meet or exceed the following miscellaneous design requirements:

- Design Vehicles - At-grade intersections shall be designed to accommodate Turnpike Double vehicles as defined in the *Alberta Transportation Highway Geometric Design Guide*;
- Rumble Strips - Longitudinal rumble strips on either shoulder or centreline shall not be used;
- Barrier - Unless noted otherwise in this Section, barriers used on mainline, connectors, ramps and C-D roads shall be modified three beam guardrail using steel posts, (Type SGR09B as defined in “*A Guide to Standardized Highway Barrier Hardware*” by the Joint AASHTO-AGC-ARTBA Committee, May 1995). The minimum length of the steel posts shall be 2.06 m. Post spacing shall be 1.905 metres. Steel offset blocks shall be used. Concrete barriers may be used at bridge locations on crossroads. Barriers that are supported on top of a retaining wall or are located closer than one-half the wall height from the top of the retaining wall shall be rigid barriers and shall meet, as a minimum, the requirements of Performance Level 2 as defined by the Canadian Highway Bridge Design Code (CSA S6-00);
- Energy Attenuator System - The energy attenuator systems for guardrail approach terminals shall pass all required tests for a Test Level 3 (TL-3) for terminals and redirective crash cushions of the *National Cooperative Highway Research Program (NCHRP) Report 350*;
- Transitions to Bridge Parapets - The transitions to bridge parapets shall pass all required tests for a Test Level 4 (TL-4) of *NCHRP Report 350*;
- Bridge Barrier - Bridge barriers shall meet, as a minimum, the requirements of Performance Level 2 as defined by the *Canadian Highway Bridge Design Code (CSA S6-00)*;
- Signals - All signal systems shall be reasonably similar to those used by the Local Authority. The signal timing shall be coordinated with the Local Authority. The signal electronics shall meet NEMA standards. All poles and hardware shall be galvanized;
- Maintenance cross-overs in the median of the mainline or between the mainline, C-D roads or ramps shall not be allowed;

- Highway accessory supports mounted on bridges or retaining walls shall be set back a minimum of 1.2 m behind the traffic barrier; and
- Roadway set-back distances from abandoned oil and gas wells shall be compliant with Alberta Energy and Utilities Board (EUB) regulations and guidelines.

200.2.5 DRAINAGE

The basis for drainage design shall be as outlined in the Functional Plan. Drainage works shall be designed in accordance with *Alberta Transportation's Drainage Guide for Highways Under Provincial Jurisdiction in Urban Areas*, as documented in the *Alberta Transportation Design Bulletins*, *Alberta Transportation's Best Practice Guidelines for Culvert Selection* and in accordance with the requirements of the Local Authority. Contrary to Page 3 of 7 of Alberta Infrastructure and Transportation's *Design Bulletin #16/2003 – Drainage Guidelines for Highways Under Provincial Jurisdiction in Urban Areas*, highway ditches should maintain a minimum slope of 0.1% to prevent standing water and also be designed to minimize velocities to avoid excessive erosion. Runoff from the New Infrastructure north of 80th Avenue NE flows into the Nose Creek watershed and the City limits discharge volumes to 1.257 l/s/ha for this watershed. Runoff from the New Infrastructure south of 80th Avenue NE must be controlled to predevelopment flow volumes of 2.5 l/s/ha.

Stormwater management facilities shall be sized to accommodate stormwater from within the Road Right of Way, remaining areas of the TUC, and pre-development flow volumes from areas outside the TUC within the natural drainage basin. The facilities shall be designed and operated to regulate all runoff discharge to receiving bodies at the prescribed locations and in quantities outlined in the Functional Plan.

Stormwater management facility locations shall be determined by the Contractor. Any proposed use of lands outside the Road Right of Way and within the TUC for stormwater management facilities shall require the Contractor to obtain prior written agreement from the Department. Stormwater management facilities in which hydro towers exist shall be shaped to allow overland access to the tower and a surrounding work area for hydro maintenance equipment at the time water levels in the pond are at design high water levels. Specific details of the access and work area requirements will be made known through the required Ministerial Consent process. The stormwater facilities shall be enclosed by fence. The stormwater facilities and fence shall be maintained by the Contractor.

If the Contractor makes an agreement to handle stormwater from outside the TUC with any party, then the Contractor shall ensure such agreements shall indemnify the Department from any future liability. Any such agreements shall require prior written approval of the Department.

Agreements for stormwater management facilities, ditch easements or other agreements which the Contractor may enter into, shall not provide for any payments from the Department without the Department's prior written consent. Such agreements must transfer to the Department at the end of the Term, at no cost to the Department, and must be enforceable in perpetuity.

The Contractor shall not sell drainage capacity in the stormwater management facilities to any third party.

The following miscellaneous drainage requirements shall be met:

- Use of smooth wall steel pipes shall require prior written agreement with the Department for the intended use;
- Manholes shall not be located within the paved area of the roadway, except for catch basin/manholes in the urban section of the crossroads; and
- All manholes in excess of 1.0 m depth shall have galvanized metal ladder rungs.

200.2.6 ROADWAY LIGHTING

The roadway lighting system shall seamlessly tie into other adjacent Provincial or Local Authority systems. Transitions shall be gradual, in both colour and intensity. The lighting system shall meet or exceed the following requirements:

- *Alberta Transportation Highway Lighting Guide Specifications*;
- Light standards shall be set back to meet clear zone requirements for the Ultimate Stage roadway;
- The lighting system shall be low or medium light pole systems. High mast system may be used in areas located 600 m or more away from existing or future residential areas;
- Light standards shall be located in the median or off the right side of the roadways for the mainline illumination and off the right side of the roadway for illumination of connectors, ramps, C-D roads and crossroads;
- The level of illumination shall meet Table 5.1 of the *Alberta Transportation Highway Lighting Guide* utilizing high pressure sodium lamps except that Deerfoot Trail and Stoney Trail Interchange (including ramps and crossroads) shall match the existing Northwest Stoney Trail design, the system interchange at 16 Avenue (including ramps and crossroads) shall be 0.6 cd/m², and all service interchanges (including crossroads) shall be 1.2 cd/m²;
- Stoney Trail shall be considered an urban freeway for the purposes of the application of Table 5.1 in the *Alberta Transportation Highway Lighting Guide*;
- Median light poles shall have breakaway bases;
- Cross roads shall be considered urban arterial for the purposes of the application of Table 5.1 in the *Alberta Transportation Highway Lighting Guide*;
- Electrical Cables - All electrical cables and communications/signals wiring shall be underground;
- Continuous lighting is required on the Northeast Stoney Trail mainline, including all ramps, connector roads, cross roads, and C-D roads;
- *The Alberta Transportation Highway Lighting Guide Specifications* shall govern when determining clear zone requirements for lighting;
- If the median clear zone exceeds 10.5m, pole heights of up to 20m may be permitted on break-away bases;

- Luminaires and poles at the Deerfoot Trail and Stoney Trail Interchange are to match existing parameters, utilizing high mast poles;
- Luminaires are to be “semi-cutoff”; and
- Lighting requirements for Service Roads shall be governed by the Local Authority in which the Service Roads exist.

The *TAC Guide for the Design of Roadway Lighting (2006)* will be incorporated into updated provincial *Highway Lighting Guide*. The *TAC Guide for the Design of Roadway Lighting (2006)* shall be a source for lighting design parameters (i.e. lighting levels and warrants). The general design guidelines from the provincial *Highway Lighting Guide* (including a general design requirements, constructing and maintenance) are still the primary guidelines to be used.

200.2.7 GUIDE SIGNING (OVERHEAD)

Guide signing for the New Infrastructure shall be designed, installed and maintained by the Contractor. The guide signing shall conform to the philosophy outlined in the Functional Plan; however, the guide signs as included in Schedule E are to be reissued to reflect specific requirements related to the staged delivery of the Functional Plan.

Location, messaging and sizing for all overhead and cantilever mounted guide signs are defined and details are included in Appendix E. The Contractor shall install and maintain all overhead and cantilever mounted signs as required by the Technical Requirements, including without limitation as set out in Appendix E. The Contractor acknowledges that certain overhead and cantilever mounted signs set out in Appendix E are located outside the TUC (the “Signs Outside the TUC”). For the Signs Outside the TUC, the Contractor shall obtain all necessary permits and approvals to install and maintain the Signs Outside the TUC.

The Clearview Highway font shall be used on all guide signing as per Design Bulletin #36, which can be found on Alberta Infrastructure and Transportation’s Web site.

The following font sizes and letter heights shall be used for the Project:

- Mainline Overhead Signage – 406 mm (16 inch) EM font.
- Mainline Shoulder Mounted Signage – 330 mm (13 inch) EM font. In cases where the street name is very long, the letter height may be reduced to 305 mm (12 inch).
- Non Mainline Overhead Signage – 330 mm (13 inch) EM font.
- Non Mainline Shoulder Mounted Signage – 254 mm (10 inch) EM font.

Overhead directional signs shall have reflective sheeting as specified under Section 300.4.2.11.1 (Reflective Sheeting).

The Contractor shall submit shop drawings using the “Clearviewhwy font software” package for the message content and layout on the major guide signs prior to manufacturing. The Contractor shall obtain the Department’s final approval of all guide sign message content prior to manufacturing.

200.2.8 LANDSCAPING

The relocation of trees impacted by the Project shall be done within the New Infrastructure Road Right of Way and/or drainage facilities if it is safe and technically feasible. These trees shall be relocated where traffic operations, safety, and drainage are not compromised.

The Province shall have the right to allow third parties, such as the Local Authority or community groups, to carry out supplemental planting or enhanced formal landscape plantings (the “Third Party Landscaping”) on lands in the TUC but outside the Road Right of Way. The Third Party Landscaping shall be on the following conditions:

- The proposed Third Party Landscaping shall not negatively impact the safety of the roadway or of the O&M;
- The Province shall own the Third Party Landscaping and the applicable third party shall maintain the Third Party Landscaping, and the Province and the applicable third party shall enter into an agreement addressing such ownership, such maintenance and any potential relocation of the Third Party Landscaping; and
- The Third Party Landscaping shall not be used for paid advertising.

Stormwater management facility wet ponds shall have vegetation for water quality enhancement, and erosion control.

200.2.9 TOPSOIL AND SEEDING

Topsoil material shall be uniformly spread to a depth of 200 mm over the prepared areas to facilitate the required seeding and landscaping. Under no circumstances shall any topsoil be buried, wasted or otherwise disposed of. In the case of large amounts of surplus topsoil, the Contractor shall indicate how the material shall be handled and stored in a manner applicable to relevant regulatory requirements. The handling and storage of topsoil is to be included in the Contractor’s Environmental Management System (Section 100.2.2) operational procedures.

Conventional seeding and/or hydro-seeding shall be carried out at the Contractor’s discretion to meet the requirements of these specifications related to drainage and erosion.

Seeded areas shall show a uniform stand of grass during the calendar year following the year of initial seeding. Areas which do not show a uniform stand of grass shall be reseeded. A uniform stand of grass will show no bare spots greater than 1 square metre in size and provide a minimum of 80% ground cover.

All seed supplied by the Contractor shall be certified free of all noxious weed varieties identified in the *Weed Control Act* (Alberta) and the City of Calgary Community Standards Bylaw.

Schedule 18 (Technical Requirements) – DBFO
Agreement

In order to maintain consistency in vegetation within the TUC, seeding of the New Infrastructure shall be the same as for the Existing Infrastructure. The following seed mixes have been used on the Existing Infrastructure:

Areas within the Road Right of Way:

Hard fescue	<i>Festuca ovina</i>	25%
Streambank wheatgrass	<i>Agropyron riparium</i>	25%
Slender wheatgrass	<i>Agropyron trachycaulum</i>	20%
Foul bluegrass	<i>Poa palustris</i>	10%
Alkali grass	<i>Puccinellia distans</i>	10%
Red top	<i>Agrostis stolonifera (alba)</i>	10%

In Stormwater Ponds (between low water level and high water level):

Northern Wheatgrass	<i>Agropyron dasystachyum</i>	20%
Western Wheatgrass	<i>Agropyron smithii</i>	15%
Slough Grass	<i>Beckmannia syzigachne</i>	15%
Tall Manna Grass	<i>Glyceria grandis</i>	15%
Canada Wild Rye	<i>Elymus Canadensis</i>	10%
Fowl Bluegrass	<i>Poa palustris</i>	9%
Annual Rye	<i>Lolium multiflorum</i>	5%
American Milkvetch	<i>Vicia Americana</i>	5%
Tufted Hairgrass	<i>Deschampsia caespitosa</i>	4%
Rough Hairgrass	<i>Agrostis scabra</i>	2%

In Stormwater Ponds above high water level:

Northern Wheatgrass	<i>Agropyron dasystachyum</i>	21%
Indian Ricegrass	<i>Oryzopsis hymenoides</i>	21%
Western Wheatgrass	<i>Agropyron smithii</i>	17%
Canada Wild Rye	<i>Elymus Canadensis</i>	10%
Fowl Bluegrass	<i>Poa palustris</i>	9%
Sandberg's Bluegrass	<i>Poa sandbergii</i>	6%
American Milkvetch	<i>Vicia americana</i>	5%
Annual Rye	<i>Lolium multiflorum</i>	5%
Tufted Hairgrass	<i>Deschampsia caespitose</i>	4%
Rough Hairgrass	<i>Agrostis scabra</i>	2%

In Dry Pond Areas:

Foothills Rough Fescue	<i>Festuca scabrella</i>	23%
Porcupine Grass	<i>Stipa curtisetata</i>	13%

Blue Grama	<i>Bouteloua gracilis</i>	13%
Western Wheatgrass	<i>Agropyron smithii</i>	10%
Northern Wheatgrass	<i>Agropyron dasystachyum</i>	10%
Indian Ricegrass	<i>Oryzopsis hymenoides</i>	9%
Sand Grass	<i>Calamovifa</i>	8%
Green Needle Grass	<i>Stipa viridula</i>	8%
Oats	<i>Avium sp.</i>	3%
June Grass	<i>Koeleria macrantha</i>	2%
Sand Dropseed	<i>Sporoboulus cryptandrus</i>	1%

200.2.10 UTILITIES

This Section 200.2.10 is subject to Section 4.8 of the DBFO Agreement. The Contractor shall locate all utility rights of way, easements, or similar interests (whether registered against title to the land or not) affected by the New Infrastructure. The Contractor shall deal with existing utilities in a manner that is consistent with the Department’s approach throughout the Province. The Contractor shall apply the information outlined in the “*Alberta Transportation Utility Guidance Manual*” when entering into an agreement with a utility company on behalf of the Department. The Contractor shall use one of the sample agreements provided in Appendix H of the “*Engineering Consultant Guidelines for Highway and Bridge Projects - Volume 1, Design and Tender, 2002*”. Prior to the agreements being signed by the utility company and the Contractor, they are to be sent to the Department for review. In the event that changes to the wording of the standard agreements are required, the changes will require prior written approval by the Department. A period of two weeks will be required to review new agreement formats after which the Department will provide comments on the suitability.

The Department has established utility contacts with the following utility companies, which are not all the relevant utility companies:

ALTALINK PO Box 20, Station M, 1035-7 Avenue SW Calgary AB T2P 2G9

Gerry McNabb T.403-267-3480 F.267-2124 gerry.mcnabb@altalink.ca
 John Rohrich T.403-267-2143 F.267-3425 john.rohrich@altalink.ca

ATCO Gas 5th Floor, 909-11 Avenue SW Calgary AB

Jeff Burton T.403-245-7406 F.245-7405 jeff.burton@atcogas.com
 Pam Smith T.403-245-7687 F.245-7405 pam.smith@atcogas.com

ATCO Pipelines 9th Floor, 10035-105 Street Edmonton AB T5J 2V6

Dale Lesik T.780-420-5482 F.420-7411 dale.lesik@atcopipelines.com

Bell Canada #2100, 111-5 Avenue SW Calgary AB T2P 3Y6

Al Glen T.403-410-8477 F.410-4018 al.glen@bell.ca
 Bill McCormack T.403-410-8276 Cell 827-2146

Calpine Canada Natural Gas Co. 2800, 111-5 Avenue SW Calgary AB T2P 3Y6

Bert Adam T.403-567-5155 F.567-5137 berta@calpinecanada.com
Ricky Leung T.403-567-5139 F.567-5137 rickyl@calpinecanada.com

The City of Calgary **PO Box 2100, Station M Calgary AB T2P 2M5**
Alex Broda T.403-268-1632 F.268-1874 alex.broda@calgary.ca

The City of Calgary-water **PO Box 2100, Station M Calgary AB T2P 2M5**
Hugh Costello T.403-268-2414 F.268-5709 hugh.costello@calgary.ca
Tanner Fellingner T.403-268-3814 F.268-5709 tanner.fellinger@calgary.ca
Trevor Moore T.403-268-5704 F.268-5709 trevor.moore@calgary.ca

CNR **CN Western Region, Box 13, 10229-127 Avenue, Edmonton AB T5E 0B9**
Tom Edwards T.780-472-4083 F.472-3725 tom.edwards@cn.ca
Al Erickson T.780-472-4093 F.472-3725 al.erickson@cn.ca

ENMAX **8820-52 Street SE Calgary AB T2C 4E7**
Barry Fraser T.403-560-0809 F.514-3954 bafraser@enmax.com

Imperial Oil **2002-4 Street Nisku AB T9E 7W4**
(Note: Includes Alberta Products Pipeline)
Rich Lamont T.780-955-6178 F.955-6139 rich.m.lamont@esso.ca
Chris McDaniel T.403-279-4493 F.279-4733 chris.s.mcdaniel@esso.ca

Municipal District of Rocky View No. 44 **911-32 Avenue NE Calgary AB T2E 6X6**
Rick Wiljamaa T.403-520-7282 rwiljamaa@rockyview.ca
Jorie McKenzie T.403-520-7294 F.277-5977 jmckenzie@rockyview.ca

Nexen Inc. **801-7 Avenue SW Calgary AB T2P 3P7**
Ray MacEachern T.403-699-5657 F.232-1676 ray_maceachern@nexeninc.com
Cell 403-860-6153

Pembina Pipeline Corp **2000, 700-9 Avenue SW Calgary AB T2P 3V4**
Les Swelin T.403-638-3852 F.638-3488 lswelin@pembina.com
Aceneth Ospina T.403-231-7434 F.231-7507 aospina@pembina.com

Shaw Cablesystems GP **2400-32 Avenue NE Calgary AB T2E 9A7**
Dana Prediger T.403-539-6769 F.539-6777 dana.prediger@sjrb.ca
Randy McKay T.403-539-6682

TELUS **TELUS Communications Inc., National Access Network Design**
715-41 Avenue NE Calgary AB T2E 3P8
Wayne Secord T.403-530-3528 F.530-4720 wayne.secord@telus.com
Steve Hall T.403-530-3470 Cell 816-3062

Zapata Energy Corporation **435-4 Avenue SW Calgary AB T2P 3A8**
Laurie McLeod T.403-294-7878 F.294-7877 lmcleod@zapata.ca

Lynda Radcliff T.403-294-7884

The Contractor shall pay all costs associated with design, utility protection, relocation, damage to or other costs with respect to all utility rights of way, easements, or similar interests (whether registered against title to the land or not) affected by the New Infrastructure.

The Contractor shall locate any abandoned utilities which impact construction of the New Infrastructure, including without limitation any abandoned Nexen Inc. waterlines and pipelines. The Contractor shall remove and decommission any such abandoned utilities in accordance with industry practice and in accordance with any applicable laws.

The Contractor shall accommodate future utility rights of way, easements, or similar interests (the “Future Utility”) on, under or above the Lands when requested by the Department. All costs associated with the installation, maintenance and operation of the Future Utility shall be the responsibility of the applicable Future Utility owner.

The Contractor shall recognize the authority of the Department to manage the TUC at all times (including both during the Construction Period and the Operating Period). The Contractor shall follow the *Transportation/Utility Corridor (TUC) Program Policy*, as may be amended from time to time, at all times when processing requests for Future Utility. For the purposes of the *Transportation/Utility Corridor (TUC) Program Policy*, the Contractor shall be considered a “stakeholder” in the TUC.

Applications for Ministerial Consent will be referred to the Contractor for comments who shall return such comments to the Department (Land Planning South) for further review. The Contractor recognizes that its comments will not be binding. In its response, the Contractor shall identify commercially reasonable steps to accommodate any proposal forwarded to it by the Department. The Contractor must be prepared (at minimum) to identify standard crossing requirements to proposed Future Utility providers at all time. The Contractor will take an open and cooperative approach in its dealings with existing and future TUC-housed utility suppliers at all times.

At the end of the Term, the Contractor shall return any and all utility as-built drawings and utility agreements to the Department.

During the Operating Period, a Future Utility may need to be removed or relocated to facilitate major maintenance or rehabilitation by the Contractor. Relocation or removal of any Future Utility, including all associated costs, shall be borne by the owner of the applicable Future Utility.

In the event that a Future Utility line is no longer required, the applicable Future Utility owner shall advise the Department and the Contractor and such owner shall arrange for the applicable Future Utility to be removed and, when applicable, for the Lands to be restored to the condition commensurate with that prior to the installation of the applicable Future Utility.

200.2.11 RAILWAYS

This Section 200.2.11 is subject to Section 4.8 of the DBFO Agreement. The Contractor shall obtain the Department's prior written approval to all railway agreements. Once approved all railway agreements are to be signed by the railway company and then sent to the Department for final execution. A period of two weeks will be required to review the agreements, after which the Department will provide comments on the suitability.

The Department has established contacts with the following railway company:

- CN (technical matters)
Contact: Tom Edwards, P.Eng., Technical Services Engineer
Telephone: 780-472-4083
Fax: 780-472-3725
Pager: 780-491-8902
E-mail: tom.edwards@cn.ca
Address: Canadian National, Operations Building, 5th Floor, Box 13, 10229 - 127 Avenue, Edmonton, AB T5E 0B9
- CN (regulatory matters)
Contact: Al Erickson, Public Works Officer
Telephone: 780-472-4093
Fax: 780-472-3725
E-mail: al.erickson@cn.ca
Address: Canadian National, Operations Building, 5th Floor, Box 13, 10229 – 127 Avenue, Edmonton, AB T5E 0B9

It shall be the Contractor's responsibility to pay all costs associated with design, railway protection and relocation associated with railway requirements.

It is the responsibility of the Contractor to conduct the work and adhere to the railway company's specifications and requirements.

200.2.12 MUNICIPAL AUTHORITIES

The Department has established contacts with the following municipality authorities or Local Authorities:

- The City of Calgary
Contact: Alex Broda, P.Eng., Director, Transportation Planning #8124
City of Calgary, Transportation
Telephone: 403-268-1632
Fax: 403-268-1874
E-mail: abroda@calgary.ca

- Municipal District of Rocky View No. 44
Contact: Rick Wiljamaa
Telephone: 403-520-7282
E-mail: rwiljamaa@gov.mdrockyview.ab.ca
Address: 911 - 32 Avenue NE, Calgary, AB T2E 6X6

200.2.13 ENVIRONMENTAL

An environmental assessment (the “Environmental Assessment”) study has been undertaken as part of the Functional Plan. All requirements identified in the Environmental Assessment including design, construction, operation, monitoring, maintenance and/or reporting, shall be the responsibility of the Contractor. The Contractor shall be responsible for obtaining and complying with all required environmental approvals, authorizations, and permits

200.2.14 NOISE ATTENUATION

The Contractor is responsible for all noise attenuation for the New Infrastructure.

The Contractor shall ensure that the maximum noise level of 65 dBA Leq₂₄ (A-weighted 24 hour equivalent sound level) measured 2 metres inside the affected property line is adhered to. If the threshold is exceeded, the Contractor shall implement noise mitigation measures. The mitigation of noise issues could include constructing noise walls or berms. The mitigation must be broadly supported by the affected residents.

In areas where a residential subdivision is constructed adjacent to an existing roadway, the development proponent will be responsible for noise attenuation.

The Contractor’s responsibility for noise mitigation applies up to and including mainline AADT volumes of 75,000, to be determined in accordance with Section 200.3.1 (Traffic Volume Payment Adjustments).

200.2.15 FENCING

Fencing shall be installed along the boundary of the Road Right of Way and extend to the TUC boundaries at the crossroads. In locations where the constructed footprint of the New Infrastructure extends beyond the Road Right of Way and for which Ministerial Consent has been granted, the fence shall follow the footprint. The fencing shall separate the Lands from the rest of the TUC. The fence shall be the Department’s Class E Standard as shown on Standard Drawing CB6-2.12M5 in Alberta Transportation’s CB-6 Manual (Highway Standard Plate) on the west side of Stoney Trail from 17th Avenue to Airport Road. The fence shall be the Department’s Class B fence in all other locations. Any stormwater management facilities shall also be fenced (see also Section 200.2.5 (Drainage)).

The Contractor must obtain approval from the Department for the proposed fence lines. The fenced areas must be of a practical size and dimension with free and clear access so that lease potential or other future uses of the rest of the TUC have not been compromised.

Access to the utility components shall be controlled by gates. The Contractor shall install gates at various locations throughout the fence line so as to permit ease of access to the utility components, ensuring that no area is inaccessible. Gates shall be large enough to accommodate passage of vehicles, equipment, utility vehicles and farm equipment. The Contractor shall obtain prior written approval from the Department for gate types, sizes and locations. TUC access will be permitted from the crossroads only. No access points will be permitted from the mainline or its associated entrance and exit ramps.

200.2.16 PREFERENTIAL BRIDGE DECK ICING

The Contractor shall address the prevention of preferential bridge deck icing on the following bridges (the “PBD Bridges”) in the Preferential Bridge Deck Icing Plan (as defined in Section 100.2.9):

PBD Bridges (New Infrastructure)

- Bridges on eastbound Stoney Trail to northbound Deerfoot Trail loop ramp;
- Bridges on southbound Deerfoot Trail to eastbound Stoney Trail loop ramp;
- Bridges on southbound Northeast Stoney Trail to eastbound Highway 1 loop ramp;
- Bridges on northbound Northeast Stoney Trail to westbound Highway 1 loop ramp;

PBD Bridges (Existing Infrastructure)

- Bow River Bridge;
- CP Railway crossing north of the Bow River Bridge;
- Highway 1 and Northwest Stoney Trail Interchange – eastbound to northbound ramp over southbound to eastbound ramp; and
- Highway 1 and Northwest Stoney Trail Interchange – eastbound to northbound ramp over Highway 1.

The PBD Bridges that are part of the New Infrastructure (the “PBD Bridges (NI)”) will be fitted with the Road Weather Information Systems (“RWIS”) by the Department’s contractor, Telvent Canada Ltd. (“Telvent”) pursuant to an agreement dated April 11, 2005 between the Department and Telvent (the “RWIS Contract”). The Contractor acknowledges having been provided with and having reviewed a copy of the RWIS Contract without the bid prices.

The Contractor shall permit Telvent to complete, prior to Traffic Availability, the installation and commissioning of RWIS on the PBD Bridges (NI).

For each of the PBD Bridges (NI), the RWIS Contractor shall be permitted by the Contractor to install sensors in the pavement approaching the applicable bridge and on the bridge itself and

install RWIS tower structures in the Road Right of Way, in locations determined by the RWIS Contractor, acting reasonably.

Once the RWIS on the PBD Bridges (NI) is commissioned and operational, the Contractor shall be entitled to receive weather forecasts from Telvent on the same terms and conditions as the Department's other highway maintenance contractors do under the RWIS Contract. The Department assumes no responsibility for the Contractor's use of such weather forecasts. The Department contact for information about the weather forecasts is:

Allan Lo, P.Eng.
Intelligent Transportation Systems Engineer
Alberta Infrastructure and Transportation
(780) 415-1021.

The Contractor shall:

- (a) provide all reasonable cooperation with Telvent, or any replacement RWIS contractor of the Department's, (the "RWIS Contractor") in respect of the installation, operation, maintenance, or rehabilitation of the RWIS for the New Infrastructure and Existing Infrastructure (the "RWIS Work");
- (b) coordinate and schedule the Project or the O&M, as applicable, in such manner as will facilitate the RWIS Work;
- (c) if and as often as it becomes aware of deficiencies in the RWIS Work as will materially adversely affect or interfere with the Project or the O&M, as applicable, or the obligations of the Contractor under the DBFO Agreement, immediately provide the Department with notice, including reasonable details, of those deficiencies;
- (d) without limiting (a) and (b) above, design, build and rehabilitate the New Infrastructure to accommodate the RWIS as set out in Drawing 18-I-01 in Appendix I.
- (e) without limiting (a) and (b) above, complete grading and landscaping to enable the installation of the RWIS tower structures for the PBD Bridges (NI) prior to Traffic Availability;
- (f) without limiting (a) and (b) above, permit the RWIS Contractor to obtain power from the power source used for the interchange lighting, provided the RWIS Contractor provides a separate power feed and meter and separately pays the power costs for the RWIS Work; and
- (g) without limiting (a) and (b) above, provide traffic accommodation services to the RWIS Contractor, as reasonably requested by the RWIS Contractor, but at the cost of the RWIS Contractor, such cost as determined by the Contractor acting reasonably.

The Department shall arrange the reciprocal reasonable cooperation of the RWIS Contractor.

For the PBD Bridges that are part of the Existing Infrastructure ("PBD Bridges (EI)"), the RWIS has been or will be installed on the following bridges:

- Bow River Bridge;
- Highway 1 and Northwest Stoney Trail Interchange – eastbound to northbound ramp over southbound to eastbound ramp; and

- Highway 1 and Northwest Stoney Trail Interchange – eastbound to northbound ramp over Highway 1.

200.2.17 INTENTIONALLY DELETED

200.2.18 MISCELLANEOUS ENVIRONMENTAL CONCERNS

200.2.18.1 Wetland Compensation

The Contractor is responsible for wetland replacement, compensation and management activities during the Project and until the end of the Term. All regulatory requirements including design, construction, maintenance, monitoring and/or reporting shall be the responsibility of the Contractor. The Department must be kept apprised of all discussions and agreements respecting wetland replacement and compensation.

200.2.18.2 Campsites

No campsites or sleeping trailers shall be allowed within the TUC.

200.2.18.3 Burning

No burning will be allowed within the TUC.

200.2.18.4 Historical Resources

A copy of the March 2, 2006 *Historical Resources Act* clearance letter is attached as Appendix “D”.

Pursuant to Section 31 of the *Historical Resources Act*, should any paleontological or historical resources be discovered during the conduct of construction activities, the Contractor shall inform the Department in writing immediately.

200.2.18.5 Pollutants

The Contractor shall ensure that no pollutant occasioned by the construction of the Project or the O&M, including debris from clearing operations, petroleum products from equipment operations and construction refuse, is allowed to enter any water body whether flowing or static.

200.2.18.6 Topsoil

Topsoil, salvaged during the Project or the O&M, shall be maintained free of deleterious material and subsoil and shall be distributed evenly over designated areas once embankment construction and excavation have been completed. No burial, removal and/or sale of topsoil materials

salvaged during the Project or the O&M is allowed without the prior written approval of the Department.

200.2.18.7 Organic Materials

Organic materials from wetland excavation shall be salvaged and stockpiled in separate stockpiles prior to reuse in accordance with environmental requirements. No burial, removal and/or sale of organic materials salvaged during the Project or the O&M is allowed without the prior written approval of the Department.

200.2.19 AESTHETICS

The aesthetics of the New Infrastructure shall be generally compatible with the northwest leg of Stoney Trail (the “Northwest Leg”). In particular, the following specific aesthetic features of the Northwest Leg shall be incorporated into the New Infrastructure:

- the “wild rose” emblem on abutment wing walls facing traffic;
- the aesthetic treatment of pier shapes for roadway grade separation bridges;
- the aesthetic treatment of concrete slope protection surfaces; and
- the use of pigmented sealers (three colours) on exposed concrete surfaces.

In addition, artistic renderings that cover a minimum of 25% of the exposed surface area shall be provided on all retaining walls except for retaining walls at railway overpasses.

The Contractor acknowledges having reviewed the plans and specifications for the Northwest Leg and acknowledges having inspected the condition of the Northwest Leg just prior to the signing of the DBFO Agreement.

Round bridge pier columns for roadway grade separation bridges shall have a minimum diameter of 1.5 metres.

The fascia surfaces of concrete bridge barriers shall have the shape shown on Alberta Infrastructure and Transportation Standard Drawing S-1700-06. Bicycle rails on top of concrete bridge barriers shall be in accordance with Alberta Infrastructure and Transportation Standard Drawings S-1700-06 and S-1701-06 published on the Department’s website.

200.3 OPERATION AND MAINTENANCE OF THE INFRASTRUCTURE

200.3.1 TRAFFIC VOLUME PAYMENT ADJUSTMENTS

The New O&M Payments and Existing O&M Payments shall be adjusted, in accordance with this Section, effective each April 1st of the Operating Period based upon changes in traffic volume calculated during the previous calendar year.

The Department shall provide automatic traffic recorder (“ATR”) devices and all connections, to the Contractor for installation by the Contractor at the Contractor’s expense on the New Infrastructure. Thereafter, the Department shall, at its own expense, operate and maintain the ATRs throughout the Operating Period on the New Infrastructure and the Existing Infrastructure.

The detailed ATR specifications are contained in Appendix H – Automatic Traffic Recorder (ATR) Specifications.

The ATRs are to be installed at or near the following locations on the Infrastructure:

- Stoney Trail mainline between Deerfoot Trail and Métis Trail NE; and
- Stoney Trail mainline between Beddington Trail and Deerfoot Trail.

No other location or measurement shall be considered for the determination of traffic volume payment adjustments.

No payment adjustments shall be made based on partial years or for changes in traffic volume within the current year.

There shall be no traffic volume payment adjustment for the first April 1st of the Operating Period.

The Department shall count the total number of vehicles to cross a point in both directions during a calendar year and shall divide this total by the number of days in that calendar year to determine the average annual daily traffic (the “AADT”). For the partial year between Traffic Availability and the subsequent April 1st, the Annual Average Daily Traffic (AADT) shall be considered equivalent to the average daily traffic measured in that partial year. The AADT shall be calculated by the Department’s traffic statistics consultant. In the event that the ATR is not recording for a given period of time, the Department’s traffic statistics consultant shall make an estimate of AADT. Weather conditions permitting, the Department shall repair the ATR to bring it into operation within four weeks of the time that the Department first becomes aware that the ATR is not functioning.

If the AADT for any calendar year exceeds 75,000 vehicles/day for the location identified on the New Infrastructure (Stoney Trail mainline between Deerfoot Trail (Highway 2) and 17th Avenue SE), a onetime supplement of 5% of a the New O&M Payment for such calendar year (before

any traffic volume payment adjustment) shall be added to each of the New O&M Payments for the 12 month period starting April 1st after such calendar year.

If the AADT for any calendar year exceeds 75,000 vehicles/day for the location identified on the Existing Infrastructure (Stoney Trail mainline between Highway 1 (West) and Deerfoot Trail), a onetime supplement of 5% of an Existing O&M Payment for such calendar year (before any traffic volume payment adjustment) shall be added to each of the Existing O&M Payments for the 12 month period starting April 1 after such calendar year.

In the event that unusual conditions, such as construction in the City, result in a temporary change in traffic volume on the mainline of Stoney Trail, the Department, in the interest of both parties avoiding unnecessary costs, will advise the Contractor that the Department wishes to negotiate with the Contractor with respect to a temporary full or partial waiver of the Traffic Volume Payment Adjustment and a corresponding temporary full or partial waiver of certain requirements under Sections 400.3 and 500.3 (Winter Maintenance Operation Requirements).

200.3.2 SNOW AND ICE CONTROL

The Contractor shall be responsible for the snow and ice control of the road surfaces as shown on Drawings 18-A-01 to 18-A-04 inclusive in Appendix A, except for the Service Roads. The Contractor shall be responsible for the co-ordination with the Local Authority to ensure all roadway surfaces are properly cleared of snow and ice during the Construction Period.

200.3.3 INTENTIONALLY DELETED

200.3.4 WEED CONTROL AND LANDSCAPE MAINTENANCE

200.3.4.1 General

All areas within the TUC east of Deerfoot Trail and north of 17 Avenue SE, except for the Privately-Owned TUC Land (as defined in section 2 of Schedule 12 of the DBFO Agreement) and the Third Party Leased Lands, shall be maintained in a weed free condition by the Contractor until Construction Completion. The “Third Party Leased Lands” are those lands as set out in Appendix G (Alberta Infrastructure and Transportation Land Lease Summary and Drawings). Thereafter, all areas within the Road Right of Way and/or stormwater management facilities of the Infrastructure shall be maintained in a weed free condition by the Contractor until the end of the Term.

Weeds to be eradicated include all species identified under the *Weed Control Act* (Alberta) and the City of Calgary Community Standards Bylaw, or species which interfere or compete with the seeded varieties. Volunteer crops from previous land use will be considered as weeds.

The Contractor shall be responsible for any fines or weed control notices issued for the TUC (between Deerfoot Trail and 17 Avenue SE), except for the Privately-Owned TUC Land (as defined in section 2 of Schedule 12 to the DBFO Agreement) and the Third Party Leased Lands, until Construction Completion and then for the Road Right of Way and/or any stormwater management facilities outside the Road Right of Way but inside the TUC until the end of the Term. All notices shall be dealt with in a timely fashion. Copies of all fines and notices shall be provided to the Department.

200.3.4.2 Method

Weed control shall be carried out by cultivation, seeding, and spraying. The areas (as set out in the first sentence of Section 200.3.4.1) not affected by the construction of the New Infrastructure as determined by the Contractor shall be tilled to ensure that all nuisance weeds are controlled. In addition, the tilled areas shall be seeded in the Spring of 2009 using the seed mixes in Section 200.2.9 (Topsoil and Seeding).

Any method of weed control adopted by the Contractor shall take into account wind directions and velocities. The Contractor shall ensure that residents located near the Infrastructure are not subjected to dust and/or spray drift resulting from its weed control operations. Natural areas shall not be subjected to spray drift. The Contractor shall be responsible for all costs associated with any damage to residential property, natural areas or retained plant materials resulting from spray drift or poor agricultural or weed control practices carried out by or for the Contractor.

In the event the Contractor chooses seeding with commercial crops as a method of weed control, any crops harvested shall become the property of the Contractor. The use of commercial crops as a method of weed control shall only be allowed during the Construction Period, not the Operating Period.

Pesticide applicators must meet all requirements in the *Code of Practice for Pesticides* (applicable by regulation under *Section 36* of the *Environmental Protection and Enhancement Act* (Alberta)). Pesticide applicators must also comply with all requirements of the *Environmental Protection and Enhancement Act* (Alberta), its associated regulations and all other applicable laws. The Contractor or any subcontractor that the Contractor hires for herbicide application must hold a valid Pesticide Service Registration with Alberta Environment, or its successor.

200.3.4.3 Weed Control Signage and Notification

The Contractor shall provide signs and notices to residents affected by the work prior to commencement of chemical applications. Signage and notification shall follow policies and procedures set by the relevant Local Authority. The Contractor shall become familiar with the policies and procedures by contacting the Local Authority for the affected area.

The Contractor shall notify the Local Authority a minimum of 48 hours prior to spraying with information including the following: location, target weeds, chemicals to be used and date and time of application.

Prior to spraying, the Contractor shall purchase all necessary signage from the Local Authority to assist in identifying spray areas. Signage shall be installed at a minimum 100 m interval and at all entry points, corridors and walkways adjacent to the TUC or as directed by the Local Authority. The Contractor shall be responsible for displaying and removing signs in accordance with the time frame required for public notification and re-entry intervals. The Contractor is to ensure that signs refer project inquires to the Contractor's contact number.

The Contractor shall be responsible for obtaining information from the relevant Local Authority regarding citizens in the vicinity of the TUC with medical sensitivities or other concerns related to spraying. The Contractor shall be responsible for determining if any such area residents are affected and then take appropriate measures to meet their specific needs.

200.3.4.4 Mowing and Fence Trimming

The Contractor shall carry out mowing and trimming around fences, as part of weed control in the following instances:

- as an emergency procedure in response to weed notices;
- to control weeds that are not effectively responding to the weed management program;
- as a clean up procedure at the end of the growing season; and
- in areas adjacent to residences where spraying is not feasible.

The trimming of weeds around fences shall be conducted as reasonably required and in any event at least once every 60 days during the period April 1 to October 31 each year.

200.3.4.5 Seed Establishment and Maintenance of Seeded Areas

Any area of unsatisfactory seed establishment shall be top dressed and reseeded by the Contractor. The acceptable minimum number of plants of all seeded species per square metre shall be 150.

The seeded areas shall be mowed/cut to 100 millimetre height a minimum of twice during the growing season. Baling and/or raking of the mowed/cut plant material shall be performed upon completion of the mowing/cutting operation in order to prevent accumulation of mulch. Bales and raked material shall be removed from site immediately upon completion of the baling/raking operation. All bales and raked material shall become the property of the Contractor.

Weeds that emerge during the one year establishment period are to be controlled as per the requirements and methods described in the Section 200.3.4.2 (Method).

200.3.5 MAINTENANCE OF DRAINAGE SYSTEMS

In addition to maintenance of the New Infrastructure drainage system, the Contractor is responsible for the maintenance of previously installed drainage systems on other portions of the Road Right of Way and the TUC as set out in Drawings 18-A-05, 18-A-06 and 18-A-07 of Appendix A. This includes the entire drainage network from the source points to the various outfalls and all features in between. The Contractor shall ensure that the design hydraulic capacity of the network as a whole and each of its elements is maintained at all times. The Contractor acknowledges as having reviewed the agreements describing the shared systems. The Contractor shall not be permitted to interfere with the function of any shared system without the permission of both the Department and the affected communities.

In the event of a roadway spill that impacts the drainage system, the Contractor shall be responsible for managing the clean up. This shall include but not be limited to implementing any safeguards to prevent contaminants from entering adjacent water bodies or the groundwater system.

200.3.6 LEVEL 2 BRIDGE DECK INSPECTIONS

Initial Level 2 Bridge Deck Inspections (as defined by *Alberta Transportation's Bridge Inspection and Maintenance System (BIM)*) shall be carried out by the Contractor in 2013 for the following bridges in the Existing Infrastructure:

- Highway 1 over Valley Ridge Boulevard (BF9467);
- Stoney Trail over Bow River (BF78812);
- Stoney Trail over CPR Tracks (BF79097); and
- Highway 1 over CNR Tracks (westbound only) (BF77090W).

Initial Level 2 Bridge Deck Inspections (as defined by *Alberta Transportation's Bridge Inspection and Maintenance System (BIM)*) shall be carried out by the Contractor in 2022 for the following bridges in the Existing Infrastructure:

- Stoney Trail over Highway 1 (BF82018);
- Highway 1 (eastbound) to Stoney Trail (northbound) over Stoney Trail (southbound) to Highway 1 (eastbound) (BF82018);
- Highway 1 (eastbound) to Stoney Trail (northbound) over Highway 1 (BF82018);
- Stoney Trail over Scenic Acres Drive (BF82403);
- Crowchild Trail over Stoney Trail (BF82405);
- Country Hills Boulevard over Stoney Trail (BF82406);
- Sarcee Trail over Stoney Trail (BF82407);
- Stoney Trail over CPR Tracks (BF82413);
- Stoney Trail over Nose Creek (BF82414);
- Deerfoot Trail over Stoney Trail (westbound) (BF82401); and
- Deerfoot Trail over Stoney Trail (eastbound) (BF82401).

Subsequent Level 2 Bridge Deck Inspections for the bridges in the Existing Infrastructure shall be carried out by the Contractor at an interval of every five years after 2013 or 2022, as applicable, until the end of the Operating Period.

200.3.7 PREVENTATIVE BRIDGE MAINTENANCE

Sealing of the bridges in the Existing Infrastructure shall initially be carried out by the Contractor in 2012 and at an interval of every four years thereafter until the end of the Operating Period.

200.3.8 INTENTIONALLY DELETED

200.3.9 SPECIAL EVENTS

There will be occasions where the Department requires the cooperation and coordination of the Contractor for special operations. Any work required by the Contractor under this Section 200.3.9 (Special Events) shall require a Change Order.

200.3.9.1 Full Lane Availability Events

Sometimes special events will be approved by the Department in the area which will generate extra traffic in the Infrastructure. Some events that generate extra traffic in the Infrastructure will occur independently of approval by the Department.

Such events may require:

- Installation of special banners or special signs;
- Adjustment of traffic signals; and
- Additional traffic management or traffic accommodation measures.

200.3.9.2 Partial or Full Closure Events

There will be times when the Infrastructure is utilized for special events (“Approved Special Events”), approved by the Department that may require closure or partial closure of the Infrastructure. The following measures may be required:

- Installation of special signs; and
- Additional traffic management or traffic accommodation measures.

The Contractor is required to develop a communications and operations plan to accommodate Approved Special Events when so notified by the Department. The Department shall approve such plan and the Contractor shall implement the approved plan.

Lane Closure Payment Adjustments shall not apply to lane closures required for Approved Special Events.

200.4 MISCELLANEOUS

200.4.1 CITY OF CALGARY

The Contractor acknowledges having reviewed a copy of a draft highway transfer agreement with the City (the “City Agreement”). The Contractor shall take all such actions, or refrain from such actions, as are necessary so as to enable the Province to comply with the Province’s obligations under the City Agreement in respect of the Project, the O&M, the New Infrastructure, and the Existing Infrastructure.

200.4.2 HOURS OF WORK / WORK RESTRICTIONS

The Contractor shall comply with the City bylaws. Work shall be restricted to the hours between 0700 and 2200, Monday to Saturday, and between 0900 and 1900 on Sundays and statutory holidays, unless the Contractor obtains a noise bylaw waiver from the City.

For work in or adjacent to the MD the Contractor shall comply with all relevant MD bylaws.

200.4.3 COORDINATION WITH LOCAL AUTHORITIES

The Contractor is responsible for coordinating all operations on crossroads with the City during construction. Should the City initiate lane rental policy for operations on City streets, the policy will not apply on New Infrastructure crossroads.

The Contractor shall contact Rick Wiljamaa, (403) 520-7282 at least 48 hours prior to commencing work on or adjacent to the MD roads.

200.4.4 POLICE AND FIRE SERVICES

Police and fire services for any area of the Infrastructure within the City will be provided by and under the jurisdiction of the City. Police and fire service for any area of the Infrastructure within the MD will be provided by and under the jurisdiction of the MD.

The Contractor shall take all such actions, or refrain from all such actions, as are necessary to enable the police, Local Authorities, and others with statutory duties or functions in relation to the Infrastructure or adjoining roads to fulfil those duties and functions. Without limiting the generality of the foregoing, the Contractor shall permit the police, Local Authority, and others with statutory duties or functions in relation to the Infrastructure, to carry out “Check Stops” and speed enforcement activities.

For any follow-up response necessary as a direct result of the emergency, the Contractor shall be responsible for all costs for such follow-up responses incurred as a direct result of the emergency including the placement and removal of barricades and timely removal of debris, which may be deposited on the Infrastructure.

200.4.5 LAND ISSUES

Administration of the TUC is undertaken by the Department on behalf of the Province. Any individual or organization proposing to enter the TUC outside the Road Right of Way to undertake an activity or use requires at least one authorization from the Department. The document entitled “*Transportation/Utility Corridor (TUC) Program Policy*” published by the Department, as may be amended from time to time, explains in detail the objectives of the TUC program. Steps for obtaining Ministerial Consent and other related authorizations from the Department are included in this policy.

200.4.6 LAND REQUIREMENTS IN THE EXISTING TUC

By Construction Completion, the Contractor shall have installed a fence separating the Road Right of Way from the remaining utility components of the TUC (the “TUC Outside the ROW”). At that time, the Department will desire to reassign the TUC Outside the ROW as lease areas. The Contractor will be relieved of its maintenance responsibility for those portions of the TUC Outside the ROW that the Contractor had responsibility, if the state of this land is acceptable to the Department. Conditions for the handover back to the Department shall require that these areas are fully vegetated and in a healthy and vigorous weed-free growing condition in accordance with the Contractor’s Environmental Management System.

Any features or appurtenances related to the roadway, such as stormwater management facilities, that may fall within the TUC Outside the ROW shall remain the responsibility of the Contractor. The Contractor shall make specific arrangements with the Department to ensure that the Contractor’s maintenance of these features does not interfere with any future tenants or other land uses.

200.4.7 INTENTIONALLY DELETED

200.4.8 WORK BY OTHER FORCES

The Contractor acknowledges it has been advised that the Existing Infrastructure work in the vicinity of the Project will be contracted by the Department and is to be completed prior to October 2009. Several contracts will be awarded to other forces before October 2009 at the Deerfoot Trail interchange. The Contractor shall coordinate all construction activities with the Existing Infrastructure contractors at the Deerfoot Trail interchange, as well as any work which

may be undertaken by utility stakeholders on their plants within the TUC or by Local Authorities at or beyond project limits.

The Contractor shall co-ordinate all construction activities with the Existing Infrastructure contractors in the area of the Highway 2 interchange.

200.4.9 VEHICLE INSPECTION SERVICES

Commercial vehicles travelling on the Alberta provincial highway system are randomly inspected and weighed by officials from the Department (currently the Vehicle Inspection Services Branch of the Department). Commercial vehicles travelling on the Infrastructure will be inspected and weighed in a similar manner and frequency as on the rest of the provincial highway system.

The Contractor may purchase at agreed upon rates additional inspection services from the Department should the Contractor wish to increase the inspection frequency to reduce the potential for overload commercial vehicles travelling on the Infrastructure.

200.4.10 SURVEY

The Contractor shall, as soon as reasonably practical after Construction Completion, obtain at its cost but on the Department's behalf, a survey (the "Survey") of the Lands. The Contractor shall provide the Department with copies of the Survey. The Contractor and the Department shall in good faith negotiate an amendment to the DBFO Agreement to describe the Lands by referencing the Survey.

300.0 DESIGN AND CONSTRUCTION - NEW INFRASTRUCTURE

300.1 INTRODUCTION

This Section covers the design and construction requirements applicable to roadways and bridge structures in the New Infrastructure.

300.2 DESIGN - GENERAL

300.2.1 GENERAL DESIGN REQUIREMENTS

The performance requirements to be met in the design of all roadways, bridge structures and other appurtenances include requirements in the areas of safety, functionality/serviceability, durability/maintainability and aesthetics. The standards to which these performance requirements are to be met are generally specified in this Schedule 18 (Technical Requirements). If a performance requirement is not specified in this Schedule 18 (Technical Requirements), the performance requirement shall be set to a standard generally being met on new roadways and bridge structures of similar type on the Provincial highway system.

Bridge structures must be designed to be structurally and operationally safe in terms of accommodation of traffic, operations and maintenance activities for the duration of the 75 year service life.

All designs shall incorporate the appropriate selection of design concepts, design details, specifications, materials and construction methods and techniques.

300.2.2 RESPONSIBILITY FOR DESIGN

The Contractor is responsible for the design of all elements of the New Infrastructure including, but not limited to, all geotechnical investigations, environmental considerations and permits, topographic surveys, in-stream watercourse surveys, approvals and permits, other field investigations and technical analysis required to complete the designs in a professional and competent manner.

300.2.3 DESIGN DOCUMENTATION

Detailed design documents shall cover the full range of infrastructure required in the Project. Design documentation shall include, but not be limited to:

- Design reports for all aspects of the work that include the design decision process, criteria and assumptions used for each aspect of the design, agreements, permits, authorizations and special construction requirements.
- Detailed design drawings prepared in accordance with the Department's *Engineering Drafting Guidelines*, including availability in electronic format.
- Comprehensive construction specifications sufficiently detailed to describe the process or end result requirements.

As a basis for this documentation, the Contractor shall further develop and finalize, as required, the design reports, plans and specifications in the Contractor's Designs, including, but not limited to:

- Design plans and profiles;
- Design cross-sections;
- Design appurtenances;
- Signing;
- Lighting;
- Roadside hazards;
- Pavement Design Report (Section 300.4.1.8.1);
- Bridge Structures Design Report (Sections 300.5.3 and 300.5.4); and
- Drainage Design Report (found in the Contractor's Designs or in the Contractor's Management Systems and Plans).

Details of design documentation requirements for these and other design issues are further expanded in this Schedule 18 (Technical Requirements).

Complete design document packages must be available prior to starting construction of the elements designed in any specific package. Any non-conformance with the Technical Requirements shall be rectified by the Contractor, whether the work has been constructed or not.

300.2.4 AESTHETICS

The Contractor is advised that the Department supports and encourages the inclusion of cost effective features to improve the overall roadway and bridge structure aesthetics.

The Contractor shall develop and incorporate in its design an aesthetic theme throughout the New Infrastructure that shall complement the surrounding environment and generally be compatible with similar features and structures located in the general vicinity, as indicated in Section 200 (Project Specifics).

Aesthetics shall be considered in the layout and design of all roadway elements. The aesthetic principles outlined in the Department's Bridge Aesthetics Study manual shall be considered in the layout, shapes, details, finishes and architectural features of all bridge structures. Any proposed aesthetic features shall take into consideration routine and long-term maintenance costs and not lead to potential maintenance and rehabilitation problems in the future.

Proposed twin bridge structures shall be aesthetically similar and constructed of the same material type. Twin bridge structures are structures spanning a common opening and close enough to be located on the same bridge approach fills. Twin bridge structures shall have similar head slopes and openings.

Bridge headslopes are typically incapable of supporting vegetation due to the shadow created by the bridge structure. On railway overpass and grade separation bridge structures, the bridge headslope shall be covered with concrete slope protection that prevents erosion and enhances the appearance of the headslopes.

All electrical and communications wiring for the New Infrastructure shall be underground.

300.2.5 PROVISIONS FOR FUTURE STAGES

During design of the roadway elements, the Contractor shall be cognizant of the requirement for future expansion through the addition of lanes or other elements as detailed in Section 200 (Project Specifics). Design and construction must feasibly allow for future economical expansion through addition of lanes and other elements.

During design of the bridge structures, the Contractor shall be cognizant of the potential requirement for future widening and/or lengthening of the bridge structures. When required, the initial design and construction of the bridge structures shall consider provisions that feasibly allow for future economical bridge structure widening and/or lengthening.

Vertical grade lines shall be set so that all vertical clearance requirements are met after any anticipated bridge structure widening and/or lengthening or roadway rehabilitation has occurred.

300.2.6 ROADWAY SAFETY AUDITS

Roadway safety audits shall be performed pursuant to the DBFO Agreement and the Contractor's Management Systems and Plans. Roadway safety audits shall follow the Transportation Association of Canada ("TAC") work scope detailed in the *Canadian Road Safety Audit Guide*, for both design and pre-opening stages. The pre-opening safety audit must be conducted after the roadway is paved and all signage and pavement markings are complete. Roadway safety audits shall be an integral part of the QMS.

The Contractor shall provide the Department as soon as practicable with a copy of the Contractor's Response Report to each of the design and pre-opening safety audits. The Contractor shall implement, at its cost, those recommendations or suggestions in the design and pre-opening safety audits as determined by the Contractor, acting reasonably. The Contractor shall provide the Department with a written explanation as to those recommendations or suggestions in the design and pre-opening safety audits that the Contractor has decided not to implement. The Contractor shall implement or shall refrain from implementing, at its costs, those recommendations or suggestions in the design and pre-opening safety audits as directed in writing by the Department.

300.3 CONSTRUCTION - GENERAL

300.3.1 RESPONSIBILITY FOR CONSTRUCTION

The Contractor is responsible for the supply of all management, professional and technical services, supervision services, construction quality control and quality assurance services, labour, materials, and equipment for performing all of the duties and obligations necessary for delivering all of the requirements of the Project. The Contractor is responsible for obtaining and complying with requirements of all permits and other authorizations required for the construction of the New Infrastructure.

The Contractor shall ensure that construction conforms to the requirements of the design. All construction is to reflect a high degree of workmanship and all materials incorporated into the New Infrastructure shall meet long-term safety, durability and functionality requirements.

Changes to the design documents during construction shall be submitted to the Department for review purposes. Any changes to the design requirements will be subject to the Change Order requirements detailed in the DBFO Agreement.

The Contractor is responsible for reclaiming all areas of the Road Right of Way and/or drainage system that have been disturbed during construction of the Project and shall obtain any required Reclamation Certificates related to these activities within 12 months of completing the reclamation activity.

300.3.2 TRAFFIC MANAGEMENT

The Contractor shall maintain the safe and efficient passage of traffic on existing roadways within the Road Right of Way. All detours required to meet this requirement shall be paved.

Requirements for the accommodation of traffic during construction and operation until the end of the Term are set out in Section 200 (Project Specifics) and Sections 400.1 (Operations – General) and 500.1 (Operations – General).

300.3.3 AS-BUILT INFORMATION

The Contractor shall compile and record information on the dimensions and physical characteristics of the New Infrastructure. The Contractor shall compile and retain the As-Built Roadway Construction Report, As-Built Surfacing Information, As-Built Pavement Structural Information, and As-Built Construction Report – Bridge Structures, As-Built Drawings, all as described below (the “As-Built Construction Reports”) that include full descriptions of each phase of the work, including, but not limited to, as-built drawings, and inspection and test reports.

The maximum time for completion and the providing of the As-Built Construction Reports to the Department shall be six months after Traffic Availability.

If the As-Built Construction Reports are not available to the Department within the specified time, a Payment Adjustment of \$10,000/month or any partial month, for every month in excess of the specified time shall apply until available.

300.3.3.1 As-Built Roadway Construction Report

The As-Built Roadway Construction Report means an as-built report that contains sufficient detail so that an independent reviewer can gain a clear understanding of the Project. The report must be in an electronic PDF format and in hard copy. The As-Built Roadway Construction Report shall contain, but not be limited to the following:

- Project title;
- Scope of the Project, Project description and site plan;
- Project staff, subcontractors, equipment and suppliers;
- Project schedule and key dates;
- Work progress, problems and solutions;
- Innovative and unique aspects of the Project;
- Safety, traffic accommodation and utility relocation;
- DBFO Agreement extensions, Change Orders, or supplemental work;
- Environmental issues;
- Photographs of key activities;
- Commentary on the materials testing results; and
- Copies of all correspondence to the Department and to the Contractor from the Department including minutes of meetings.

300.3.3.2 As-Built Surfacing Information

The Contractor shall prepare an as-built report known as the “As-Built Surfacing Information” which shall include but not be limited to the following:

Project Description - A complete description of the Project, including, but not limited to, the following:

- Highway control section number (e.g. 2:02);
- Project title;
- Project description and site plan;
- Project staff, subcontractors, equipment and suppliers;
- Surfacing schedule and key dates;
- Work progress, problems and solutions;

- Innovative and unique aspects of the surfacing;
- Safety, traffic accommodation and utility relocation;
- All concrete and asphalt mix designs;
- Change Orders;
- Environmental issues;
- Width and thickness charts;
- Photographs of key activities;
- Commentary on the materials testing results for grading and granular base course; and
- Commentary and summary of asphalt pavement and Portland cement concrete testing results.

300.3.3.3 As-Built Pavement Structural Information

The Contractor shall prepare an as-built report known as the “As-Built Structural Information” which shall include, but not be limited to:

Width and thickness diagrams - for each homogeneous section greater than 200 m in length, containing:

- Soil classifications;
- Subgrade additives used, if any (e.g. lime);
- The applicable plans, annotated to show any deviation from the original design;
- The results of any coring or drilling undertaken on the Project;
- The finished surface width (rounded to the nearest 100 mm);
- The constructed sideslope ratios of pavement structure and subgrade as applicable; and
- The constructed pavement structure thickness (rounded to the nearest 5 mm) including:
 - The thickness of each layer; and
 - The type and grade of asphalt cement and/or type and classification of Portland Cement concrete used.

300.3.3.4 As-Built Construction Report - Bridge Structures

The Contractor shall prepare an as-built report known as the “As-Built Construction Report – Bridge Structures” which shall contain, but not be limited to the following:

- Shop drawings for bridge material fabrication;
- Weld procedures;
- Mill reports for stressing strand;
- Stress-strain curves for stressing strand;
- Stressing calculations;
- Camber records;
- Construction Data Sheets for precast concrete girders;
- Mill certificates;

- Test reports for Charpy impact, hardness, radiography, ultrasonic, magnetic particle, and dye penetrant;
- Heat treatment records;
- Concrete and asphalt mix designs;
- Pile driving, pile drilling, foundation records;
- Concrete test results;
- Post-tensioning and stressing records;
- Material testing results including gradation analysis for backfill materials, clay seal, etc.; and
- Any other information recorded as part of the QMS and required to document material properties or construction details.

The documents listed in Section 300.5.4 (Final Design Report Requirements), shall also be submitted as part of the As-Built Construction Report - Bridge Structures.

300.3.3.5 As-Built Drawings

As-Built drawings are to be stamped and signed by a Professional Engineer.

As-Built drawings shall be in the same format as design drawings. The Contractor shall supply 3 mil matte finish mylar film drawings and digital copies in Microstation.dgn format of all As-Built drawings for the Department's record purposes.

The As-Built drawings shall show all relevant details of the New Infrastructure including, but not limited to, bridge structures, horizontal alignment, vertical alignment, cross-section elements, intersection layouts, interchanges, etc. Details of signing and pavement markings shall be described through reference to standard plans where possible. A detailed description and location of all underground utilities and conduits, showing horizontal locations, elevations, size and type of utility, etc., shall be shown on As-Built drawings.

300.4 ROADWAYS

300.4.1 DESIGN REQUIREMENTS

300.4.1.1 Geometric Design

The design shall be undertaken in accordance with the latest edition of *Alberta Transportation's Highway Geometric Design Guide* and applicable *Design Bulletins*, Section 200 (Project Specifics) and where noted, associated reference manuals or guidelines. Where specific design elements are not included in the *Alberta Transportation's Highway Geometric Design Guide* and applicable *Design Bulletins*, the design shall be undertaken to conform to the *TAC Geometric Design Guide for Canadian Roads*.

The design shall utilize, as a minimum, the design criteria stipulated in Section 200 (Project Specifics). Where design criteria are not specified, desirable design criteria shall be utilized, except where minimum design criteria are acceptable to the safety auditor. In no circumstance will the use of combinations of inter-related minimum design criteria be accepted.

The Contractor shall consider the ultimate design identified in the Functional Plan, or as detailed in Section 200 (Project Specifics), in all design decisions in order to facilitate any additions to the New Infrastructure within the Term or later. The design shall consider future costs, throwaway costs, user costs, safety, and identify an optimal design within such constraints. Life cycle cost considerations shall be documented in the design report to support the design decisions. The Project mainline, ramps and crossroads shall be designed for the design speeds identified in Section 200 (Project Specifics).

300.4.1.2 Intersections and Interchanges

The design of at-grade intersections shall be in accordance with *Alberta Transportation's Highway Geometric Design Guide* and any applicable *Alberta Transportation Design Bulletins*.

Interchanges shall be designed to the configurations established in the Functional Plan, to Section 200 (Project Specifics), or to equivalent alternative configurations accepted by the Department.

300.4.1.3 Soils

The Contractor shall undertake the grading design with due consideration for the soil types encountered. A geotechnical investigation shall be carried out by the Contractor in sufficient detail to allow for the identification of all soils issues.

The Contractor shall prepare detailed geotechnical reports for the entire Project for the purpose of documenting soil conditions and the engineering recommendations for all soils issues. The reports shall be completed in accordance with the *Canadian Foundation Manual* and the Department's *Engineering Consultant Guidelines for Highway and Bridge Projects*.

300.4.1.4 Drainage

The drainage design shall prevent damage to the Road Right of Way, the TUC and the lands adjacent the TUC, caused by flooding or drainage problems.

The Contractor shall be responsible for obtaining all necessary permits and authorizations from, but not limited to, Alberta Environment, the Department, Department of Fisheries and Oceans, and the Local Authority, as applicable.

The drainage design shall include erosion control installations necessary for the in-situ conditions of the drainage works. The Department's *Design Guidelines for Erosion and Sediment Control for Highways* may be considered for such designs.

300.4.1.5 Hazard Protection

The use of barriers shall be limited to those areas where it is necessary to protect the travelling public from roadside hazards. All grade line design shall be such as to minimize the need for barriers.

The Contractor shall utilize the appropriate barrier configuration for providing protection for roadside hazards based on safety considerations. For drainage obstructions, the Contractor shall undertake the design to minimize the need for protection. In any special circumstance where protection is required, the Contractor shall protect the public from the hazard using a barrier that has passed all required tests for *NCHRP Report 350*, Test Level 3, unless otherwise specified in Section 200 (Project Specifics).

The Contractor shall use barrier end treatments that have passed all required tests for *NCHRP Report 350*, Test Level 3.

Where barriers are required and cannot be avoided by altering design characteristics of the roadway, thrie beam rail shall be used. The rail, support posts, and ancillary hardware shall be specified to meet the performance requirements described in *NCHRP Report 350*, Test Level 3 and Section 200 (Project Specifics).

300.4.1.6 Roadway Lighting

The Contractor shall design the roadway lighting in accordance with the requirements of the *Alberta Transportation Highway Lighting Guide*. The design shall result in lighting to levels

identified in Section 200 (Project Specifics) for the full length of all roadways. The poles and bases shall meet the requirements of the *Alberta Transportation Highway Lighting Guide*.

All designed systems shall be in accordance with the *Canadian Electrical Code* and the regulations of the electrical inspection department having jurisdiction. The Contractor shall prepare shop drawings of all electrical components as part of the design. The drawings shall include poles, luminaires, distribution enclosures and bases. Shop drawings shall be stamped and signed by a Professional Engineer.

300.4.1.7 Landscaping

All non-hard surfaced areas within the Road Right of Way and other disturbed areas within the TUC shall be topsoiled and seeded to grass as noted in Section 200 (Project Specifics).

300.4.1.8 Pavement Structure

The Contractor shall design the pavement structures in accordance with recognized design procedures on the basis of actual soil parameters for the roadway subgrade. The pavement structures for all roadways within the New Infrastructure shall be designed with no reduction of or restrictions to allowable legal load(s), during spring time thawing conditions or at any other time. For pavement designs such as final-stage paving and rehabilitation, the method shall utilize back-calculated moduli values that the Contractor shall determine based on non-destructive testing.

Materials for the roadway surface may be asphalt concrete pavement or Portland cement concrete pavement. All travelled lanes and full shoulder widths shall be paved. Shoulder and lane materials do not have to be the same, however the potential for future widening must be addressed in the design such that increased cost does not result at the time of any future widening. The subgrade widening at tie-ins to existing roadways shall be constructed to avoid disruption of drainage along the subgrade surface and protect the integrity of the existing pavement structure. Pavement structure variation for New Infrastructure shall be introduced beyond the tie-in point to preserve subgrade drainage and structural integrity of existing roads.

The pavement structure design shall account for future widening as stipulated in the Functional Plan and Section 200 (Project Specifics). The design shall identify how the future expansion will be accomplished in a cost effective manner. The pavement design shall provide for the shoulder thickness on the side(s) proposed for future widening to provide structural capacity for use as a portion of the future lane(s).

300.4.1.8.1 Pavement Design Report

The Contractor shall prepare a pavement design report, for both new construction and subsequent preservation and rehabilitation strategies that shall include, as a minimum:

- All pertinent design inputs such as traffic, soils characteristics, characteristics of the proposed construction materials, environmental inputs to the design and for rehabilitation designs, the existing pavement structure;
- Site plan showing the limits of the roadway covered by the design report;
- Discussion of the inputs used to arrive at design recommendations and the rationale used in selecting the recommended design strategy;
- Typical cross section drawings for the recommended pavement design strategy; and
- For rehabilitation designs, graphical presentation of calculated moduli, overlay needs, and existing cross sections.

300.4.1.9 Traffic Control Devices

300.4.1.9.1 Signs

Sign patterns for standard signs shall conform to the *Alberta Transportation Sign Pattern Manual*. For signing not addressed by the *Alberta Transportation Sign Pattern Manual*, sign patterns shall conform to the *TAC Uniform Traffic Control Devices of Canada Sign Pattern Manual*. All lettering on signs shall conform to the series Type Highway Font from the *Standard Alphabet for Highway Signs*, available from the Federal Highway Administration (CHTO-20), Washington, D.C., 20590, unless otherwise specified by the *Alberta Transportation Sign Pattern Manual* or the *TAC Uniform Traffic Control Devices of Canada Sign Pattern Manual* for the applicable signs.

300.4.1.9.2 Traffic Signals

All traffic signal installations, including pedestrian controls, shall be designed in accordance with the current edition of the *TAC Manual of Uniform Traffic Control Devices for Canada*, and the *Canadian Capacity Guide for Signalized Intersections*. The Contractor shall identify as part of the Contractor's Designs any planned staging of signal installations (the "Planned Future Signal Installations") based on traffic volumes at other locations on the New Infrastructure. The Contractor shall verify annually the signal warrants for any unsignalized intersection within the Road Right of Way using the procedures set out in Section B.2 of the *TAC Manual of Uniform Traffic Control Devices for Canada*, and shall submit the warrant calculations to the Department as soon as practicable after verification. If the Total Priority Points (as defined in the *TAC Manual of Uniform Traffic Control Devices for Canada*) is equal to or greater than 80 and if instructed to do so in writing (the "Notice") by the Department, the Contractor shall install traffic signals at such applicable intersection(s) within 12 weeks after the Notice (the "Installation Deadline").

If the Contractor fails to complete the Planned Future Signal Installations on or before the Installation Deadline, the "first occurrence of a non-functioning signal location" of the Payment Adjustments set out in Section 400.4.8.2.3 (Traffic Signals – Payment Adjustments) at an amended rate of \$500/day or any partial day, until rectified shall apply as if the Planned Future Signal Installations had been completed but for 24 hours per day the deemed installed signals

were not at all operational. For the purpose of applying such Payment Adjustment, the time stipulated for completing repairs as set out in Section 400.4.8.2.2 (Traffic Signal – Completing Repairs) shall be deemed to have expired on the Installation Deadline. The foregoing Payment Adjustment shall continue to accrue and be payable until such time as the Contractor completes the Planned Future Signal Installations.

The Contractor shall design all signalization to interface with the Local Authority signal system. The Contractor shall cooperate with the Local Authority to meet all of the requirements of the Local Authority's control system and have the ability to be controlled by the Local Authority's system.

Changes to signal timing may be initiated by the Contractor, the Local Authority or the Department. Such changes shall be accommodated at the cost of the Contractor over the Term.

All electronics shall be NEMA approved electronics. LED lights shall be implemented as per Alberta Infrastructure and Transportation's Design Bulletin #32 "LED Lamp Usage in Traffic Signals, Pedestrian Signals and Beacons". All signals shall be mounted on cantilever style poles and no alternative mounting systems will be allowed at any time. All poles and associated hardware shall be galvanized. All signal systems shall be similar in appearance to those used by the Local Authority on roadways of the same standard in adjacent areas.

300.4.1.9.3 Pavement Markings

The Contractor shall design, install and maintain painted or durable pavement markings with or without "cat eye reflectors" in conformance with the *Alberta Transportation Pavement Marking Guide* and the *Alberta Transportation Highway Geometric Design Guide*.

300.4.1.10 Miscellaneous

300.4.1.10.1 Fencing

Fencing shall be designed and installed along the entire length of the Lands and around any stormwater management facilities related to the New Infrastructure outside the Lands but inside the TUC, as specified in Section 200 (Project Specifics).

300.4.2 MATERIALS

The Contractor shall select the materials to be used for construction and ongoing maintenance to meet the Technical Requirements. Where materials, such as culverts and ducting, have an expected life of greater than 30 years, the selection of the appropriate materials shall be based on a minimum of a 50 year life for the material.

Except for reclaimed asphalt pavement ("RAP") materials, all construction materials shall be new materials.

300.4.2.1 Topsoil

Topsoil shall consist of a natural, friable surface soil of organic character, suitable for agricultural purposes.

300.4.2.2 Aggregates

Aggregates for Portland cement concrete shall be suitable for use in concrete, shall exhibit suitable long term performance characteristics and shall conform to the requirements of CSA Standard 3-A23.1. Specifically, aggregates for use in concrete pavements or appurtenances shall exhibit suitable resistance to alkali-aggregate reactivity.

Aggregates for use in asphalt concrete shall be selected to provide suitable long term performance.

300.4.2.3 Portland Cement Concrete

Portland cement concrete for use in roadway elements including pavements, curbs, gutters, sidewalks, barriers or other appurtenances shall consist of a mixture of Portland cement, supplementary cementing materials, fine aggregate, coarse aggregate, water and admixtures where required, in proportions to meet the requirements of the design.

Portland cement concrete designed for any application that will be in contact with winter maintenance materials shall consist of materials shown to provide adequate resistance to scaling and other freeze thaw damage.

The Portland cement used shall meet the requirements of CSA Standard 3-A5, Portland Cement, for the type of cement specified. The Portland cement concrete shall meet all the requirements of CSA Standard A23.1. For CSA A23.1 Section 17.4.2, Air Content of Hardened Concrete, the confirmation of the air-void system shall be on drilled cores obtained from the in-place concrete.

300.4.2.4 Asphalt

Asphalt binders shall meet the requirements of the Canadian General Standards Board CAN/CGSB-16.3-M90 and/or AASHTO requirements for Performance Graded (PG) asphalts or their equivalent for the type(s) of asphalt binders used. The use of non-standard PG grades, e.g. split grades, is acceptable.

300.4.2.5 Fencing Materials

Fencing materials are defined in Section 200.2.15 (Fencing).

300.4.2.6 Reinforced Concrete Pipe

Reinforced concrete pipe for storm sewers or culvert applications shall conform to the material and fabrication requirements of CSA Standard A257.2. Concrete manhole risers and tops shall conform to all the material and fabrication requirements of CSA Standard A257.4.

Joints for circular concrete and culvert pipe using flexible rubber-type gaskets shall conform to all the material and fabrication requirements of CSA Standard A257.3.

300.4.2.7 Polyvinyl Chloride Pipe

Polyvinyl chloride (“PVC”) pipe shall be made of virgin PVC plastic as defined in CSA Standard C22.2 No. 211.1. Gaskets for PVC pipe shall conform to the requirements of CSA Standard B182.2.

300.4.2.8 Smooth Walled Steel Pipes

Smooth walled steel pipe materials are described in Section 200 (Project Specifics).

300.4.2.9 Corrugated Metal Pipe And Pipe Arches

Corrugated metal pipe and pipe arches (less than 1.5 m diameter) shall be selected to insure a minimum design life of 50 years for the soil conditions in which they are to be installed. Any pipe 1.5 m or larger is considered a bridge structure.

Corrugated steel pipe (“CSP”) and pipe arches including couplers and appurtenances shall be galvanized, polymer coated or aluminum coated in accordance with the latest edition of CSA Standard G401.

Corrugated aluminum pipe (“CAP”) and pipe arches including couplers and appurtenances shall be manufactured to meet the requirements of AASHTO M196 and M197 and shall be marked with the manufacturer’s name or trade mark and the date of manufacture.

During installation, any damaged coating shall be reinstated with the appropriate material in accordance with CSA Standard G401.

300.4.2.10 Curbs, Gutters, Medians, Traffic Islands, Sidewalks and Other Appurtenances

All curbs, gutters, raised medians, traffic islands, sidewalks and other appurtenances shall be constructed with Portland cement concrete.

300.4.2.11 Permanent Highway Signs, Posts and Bases

300.4.2.11.1 Reflective Sheeting

Reflective sheeting shall meet or exceed the minimum requirements as specified in ASTM D4956 for Type III Retro-Reflective Sheeting Material and Section 200 (Project Specifics).

For installations of the following signs:

- RA-1 "Stop";
- RA-2 "Yield";
- RB-22 "Wrong Way"; and
- RB-23 "Do Not Enter".

The Contractor shall supply reflective sheeting complying with the minimum coefficient of retroreflectivity (R_A (cd/lux/m²)) as shown in the following table:

Observation Angle	Entrance Angle	White	Red
0.2°	-4°	370	98
0.2°	+30°	225	65
0.5°	-4°	275	70
0.5°	+30°	125	32

300.4.2.11.2 Sign Posts

Sign post material shall be consistent throughout the New Infrastructure excepting that the Contractor may elect to use either metal or wooden posts for single post installations, provided all single posts are of the same material.

300.4.2.12 Pavement Marking Materials

The Contractor shall supply pavement marking materials that will meet the requirements of the design and the performance requirements in Section 400.4.8.3 (Pavement Markings). Re-application shall meet the same performance requirements.

300.4.2.13 Guardrail and Posts

Guardrail and post materials are described in Section 200 (Project Specifics).

300.4.2.14 Intentionally Blank

300.4.2.15 Flexible Guide Post Traffic Delineators

Material for flexible guide post traffic delineators shall meet the requirements of *Alberta Transportation Standard Specifications for Highway Construction*, Specification 5.28, Supply Flexible Guide Post Traffic Delineators.

300.4.2.16 Intentionally Blank

300.4.2.17 Underground Electrical Conduit and Cable Ducts

Underground electrical conduit utilities shall meet the requirements of the *Alberta Electrical and Communication Utility Code* and *CSA Standard C223 No. 7-94 “Underground Systems”*, with amendments as listed in the *Alberta Electrical and Communications Utility Code* and *CSA Standard B196.3 “PVC Underground Telecommunication Cable Ducting and Fittings”*. All underground utility work shall be coordinated with the appropriate utility and shall follow the requirements of the *Canadian Electrical Code, Part 1, C22.1*.

300.5 BRIDGE STRUCTURES

300.5.1 GENERAL

300.5.1.1 Existing Reference Documents

The Contractor is advised that the Department has an existing “*Bridge Structures Design Criteria*” document that outlines the requirements for the design of bridge structures. While the provisions of the document are not directly binding for the Project, it is based on the Department’s past experience and best practices and will provide some guidance and assistance during the detailed design of the bridge structures.

Additionally, the Department has a number of existing standard drawings that address bridge rails, approach rail, deck joints and other elements. While these standard drawings are not directly binding for the Project they are based on the Department’s past experience and best practices and will provide some guidance and assistance in the design of the bridge structures.

Documents that are binding to the Project are noted below.

- *Bridge Welding Code (AWS D1.5);*
- *Canadian Highway Bridge Design Code (CSA Standard S6-00);*
- *Alberta Transportation’s Engineering Drafting Guidelines for Highway and Bridge Projects;*
and
- *Alberta Transportation’s Navigable Waters Protection Act Procedure Manual.*

300.5.2 DESIGN CRITERIA

300.5.2.1 Design Codes

The Contractor shall complete all bridge structure design in accordance with *CAN/CSA-S6-00 (Canadian Highway Bridge Design Code)* (the “Bridge Design Code”) or in accordance with other standards with the prior written approval of the Department, and in accordance with other relevant codes and recognized current engineering practices and specifications, unless noted otherwise.

A new edition of CAN/CSA S6 is expected to be published in 2006. When this new edition of CAN/CSA S6 is published it is anticipated that it will be adopted as the Bridge Design Code provided that this is mutually agreeable to the Department and Contractor.

Unless otherwise noted, all provisions of the Bridge Design Code shall be incorporated in the design of the bridge structures except as follows:

- Live load distribution factors used for girder design shall not be less than the empirical factors specified in the Bridge Design Code unless specifically agreed to in writing by the Department. If a bridge does not satisfy the criteria that allow the empirical factors to be used, the live load distribution factors used for girder design shall not be less than the empirical factors that would have been used if the bridge had met these criteria;
- Intermediate diaphragms are required in bridge structures with concrete beam and slab superstructures unless their omission is agreed to in writing by the Department. Intermediate diaphragms in bridge structures with steel beam and slab superstructures shall have a maximum spacing of 8.0 m. Intermediate diaphragms in bridge structures with precast concrete beam and slab superstructures shall have a maximum spacing of 12.0 m;
- Stiffened plate girder webs shall in no case have intermediate transverse stiffeners spaced at greater than 1.5 times the girder depth unless specifically agreed to in writing by the Department;
- Diaphragms shall be at least $\frac{1}{3}$ and preferably $\frac{1}{2}$ the girder depth;
- Notwithstanding Section 1.5.2.5 of the Bridge Design Code, approval will not be given for the use of single load path structures. Slab and girder bridge structures shall have a minimum of four girder lines;
- Notwithstanding Section 8.8.4.6 of the Bridge Design Code, no tension is allowed in concrete at the top of deck level in post-tensioned superstructures at serviceability limit states. Tension is also to be limited to the minimum of 0.8 fcr or 2.0 MPa at the bottom flange level for pre-tensioned or post-tensioned superstructures;
- Clear cover to reinforcing steel shall be in accordance with Section 8.11.2.2 of the Bridge Design Code except as follows:
 - clear cover from the roadway face of curbs, barriers, medians and sidewalks shall be 100 mm, with a tolerance of +10 mm, -0 mm;
- Approach slabs shall have sufficient length to limit their rotation due to settlement to 1.0%. Notwithstanding Section 1.8.2 of the Bridge Design Code, they shall have a minimum length of 3.6 m;
- Notwithstanding Section 1.8.3.2 of the Bridge Design Code, utilities may be placed in voids of up to 300 mm diameter even though the voids are not accessible for inspection and maintenance;
- In Section 5.7.1.3 of the Bridge Design Code the width (B) of the bridge may be assumed to be reduced to a width that provides a value of $\Xi < 10$. The number of design lanes (n) shall be reduced as required to be consistent with the assumed bridge width (B);
- Notwithstanding Sections 8.4.1.2, 8.11.2.1 and 8.23.2 of the Bridge Design Code minimum concrete compressive strengths shall be 25 MPa for piles, 35 MPa for substructure components and 45 MPa for superstructure components;
- Notwithstanding Section 8.11.2.5 of the Bridge Design Code, aggregates for concrete may be assumed to be moderately reactive in the absence of testing for alkali-aggregate reactivity;
- Notwithstanding Section 8.18.4.1 (b) of the Bridge Design Code, the maximum girder spacing to slab depth ratio shall be 15.0;
- Notwithstanding Section 10.6.3 of the Bridge Design Code, all superstructure steel shall meet the requirements of CSA Standard G40.21M, Type AT, Category 3 steel, except that secondary members not welded to the primary load carrying members may meet the requirements of CSA Standard G40.21M, Type A;

- In Section 10.17.2.6 of the Bridge Design Code the formula for Z_{sr} shall be changed from “ $Z_{sr} = (238 - 29.5 \log N_c) d^2 > 38d^2$ ” to “ $Z_{sr} = (238 - 29.5 \log N_c) d^2 > 38d^2/2$ ”;
- All superstructure steel surfaces shall be uncoated with the exception of exposed surfaces of steel girders within 2.0 m of an integral abutment which shall be coated with Termarust Series 2100 paint. The colour of the coating shall match the colour of the weathering steel;
- Notwithstanding Sections 10.23 (Fracture Control) and 10.24 (Construction Requirements for Structural Steel) of the Bridge Design Code, the supply, fabrication, delivery and erection of structural steel shall be in accordance with Section 300.5.8 (Structural Steel);
- Notwithstanding Section 11.5.1.1 of the Bridge Design Code, deck joints shall be recessed 5 mm below riding surfaces and 8 mm behind the vertical traffic faces of curbs, sidewalks, medians and barriers. The free ends of any cover plates shall be pointed towards the bridge abutments;
- Notwithstanding Section 11.5.3.1 of the Bridge Design Code, the maximum opening for a single deck joint opening shall be 115 mm. Slope movement bars that maintain a minimum joint opening of 60 mm for seal replacement shall be provided;
- Notwithstanding Section 11.6.1 of the Bridge Design Code, a grout pad with a 40 mm deep grout pocket shall be used under bearings. The grout pocket shall extend 75 mm beyond the edges of the base plate;
- The requirement in Section 11.6.1 of the Bridge Design Code for one extra degree of rotational capacity may be waived for elastomer bearings if the base plate under the bearing is self-levelling;
- Notwithstanding Section 11.6.3.3 of the Bridge Design Code stainless steel used in sliding surfaces of bridge bearings shall be AISI Standard Type 304 with a No. 8 mirror finish;
- Elastomeric bearings shall be held in position by keeper bars on all sides of the bearing. The keeper bars on one side of the bearing shall be removable;
- Bearings shall not be subjected to uplift at the Serviceability Limit State or Ultimate Limit State;
- Notwithstanding Section 11.6.3.4.1 of the Bridge Design Code unconfined sheet PTFE may be bonded to an elastomeric bearing with a Shore A durometer hardness of 60;
- Notwithstanding Section 11.6.6.2.2 of the Bridge Design Code elastomeric bearings shall conform to Section 18 “Bearing Devices” Division II of AASHTO. The elastomer shall meet the requirements of AASHTO Grade 5; and
- Notwithstanding Section 3.15 of the Bridge Design Code, bridge structure supports, e.g. piers, abutments, retaining walls, located within 10 metres of the Ultimate Stage pavement of a roadway with a design speed greater than or equal to 80 km/h shall be designed for an equivalent static vehicle collision force of 1800 kN, assumed to act in any direction in a horizontal plane, at a distance of 1.2 metres above ground level at the pier.

300.5.2.2 Design Load

Bridge structures shall be designed for a minimum highway live load of *CAN/CSA-S6-00* CL 800 plus dynamic load allowance. Any pedestrian bridge structures or pedestrian elements shall be designed in accordance with *CAN/CSA-S6-00* Clause 3.8.9.

All bridge structures shall be designed to comply with Class A Highway Requirements of *CAN/CSA-S6-00*.

Additionally, bridge structures that are designed and constructed without any initial asphaltic wearing surface shall be designed for the provision of a future 50 mm thick wearing surface.

300.5.2.3 Hydrotechnical

Unless otherwise noted, the provisions of *CAN/CSA-S6-00* with reference to Section 1.2.3 Hydraulic Definitions and 1.10 Hydraulic Design shall NOT apply to the Project.

For proposed bridge structures over watercourses, including bridge size culverts (1.5 m diameter or larger), the Department will evaluate the proponent's hydrotechnical design using the Department's current "*Hydrotechnical Design Guidelines*" document.

Bridge structure openings on watercourses shall be sized and protected so that over the 75 year service life of the structure they do not:

- Cause an unacceptable level of flooding on neighbouring flood sensitive lands and developments;
- Cause any flooding of the highway road surface;
- Have a negative impact on local channel stability; and
- Cause erosion affecting the stability of the bridge structure or roadway fills.

300.5.2.3.1 Minimum Freeboard for Stream Crossings

Bridges shall be designed to have a minimum 1.0 m freeboard.

Bridge size culverts shall be designed to have a minimum freeboard of one-sixth the culvert diameter (to a maximum of 1.0 m) and a minimum invert burial depth of one-quarter the culvert diameter (to a maximum of 1.0 m).

300.5.2.4 Geotechnical

Bridge structure foundations shall be designed in accordance with *CAN/CSA-S6-00* (*Canadian Highway Bridge Design Code*). Bridge substructure elements shall be supported on pile foundations.

Silt material shall not be used in the design and construction of headslopes and approach fills for the bridge structures. The headslopes and approach fills, including the effects of retaining walls, shall be designed for a minimum factor of safety of 1.3 at the time of construction completion.

The design of the bridge approach fills shall account for long-term settlement. Any differential settlement between the bridge structure and approach fills shall not cause a deviation of more than 1% from the roadway design grade.

300.5.2.5 Geometrics

The Contractor shall design a roadway grade line that optimizes the location and length of the bridge structures. Where practical, bridges shall be located on tangent horizontal alignments.

In addition to and notwithstanding the geometric design requirements stated in Section 200 (Project Specifics), bridge decks shall have a maximum grade of 3%.

For deck drainage purposes, the Department considers a minimum grade of 1% to be desirable. However, the Department recognizes that grade line constraints for grade separation structures may require crest curves that result in portions of the bridge deck having a grade of less than 1%.

Bridge deck widths shall as a minimum have the same width as the clear roadway on the bridge approaches. The bridge deck shall also have a 2% crown unless the grade line over the bridge structure is superelevated.

Bridge structure support locations, e.g. piers, abutments, retaining walls, shall not be located within the underpassing roadway's clear recovery zone and shall allow all required sight distances to be met.

The vertical clearance posting (as determined below) for any grade separation bridge structures shall be a minimum of 5.4 m for the duration of the Operating Period. Future overlays on the mainline roadway under the grade separation bridge structure shall not result in a vertical clearance posting (as determined below) below 5.4 m at any time during the Operating Period.

The minimum vertical clearance for any sign structures over the roadway shall be the greater of 6.0 m or 300 mm higher than the lowest grade separation structure in the vicinity.

The Department's process for determining the vertical clearance posting is as follows:

- Measure minimum vertical clearance between the roadway surface and lower bottom edge of the girder within roadway width including shoulders to the nearest centimetre (i.e. 5.74 m);
- Round down to the nearest decimetre (i.e. 5.7 m); then
- Subtract one decimetre for tolerance (i.e. Post vertical clearance as 5.6 m)

300.5.2.6 Preferential Bridge Deck Icing

Bridge decks that are on a resultant slope of 4% or greater due to roadway grade and cross-slope or are located in areas where changes in traffic speed are required, shall be designed with systems that can either prevent preferential bridge deck icing or predict its occurrence in advance so that preventative measures can be taken.

300.5.2.7 Durability

Bridge structures shall be designed for a service life of 75 years. The designs shall recognize the need for ease of replacement of components whose service life is expected to be less than 75 years and the provision of access for inspection and maintenance. The level of maintenance, rehabilitation and/or repair required during the service life of the bridge structures shall be consistent with or better than that generally anticipated to be required for other bridge structures of similar age and type on the Provincial highway system.

The Department's standard system for protecting a bridge deck from deterioration due to de-icing salts and rebar corrosion consists of a combination of:

- A silica fume concrete deck;
- Epoxy-coated deck rebar; and
- A waterproofing membrane on the deck riding surface.

The Department has had successful experience with this deck protection system and is satisfied with its performance. Alternative deck protection systems shall not result in a higher level of maintenance, rehabilitation and/or replacement over the last 45 years of the bridge's service life than the Department's standard system.

The number of deck joints shall be kept to a minimum and bridge superstructures shall be continuous for live load over the piers. All deck joints shall include provision to capture and manage deck drainage such that it does not come into contact with other concrete and steel surfaces of other bridge elements.

Silica fume concrete shall be used for all bridge decks, curbs, sidewalks, medians, roof slabs, approach slabs, concrete overlays and any other bridge components that will come into direct contact with de-icing salts.

An approved Type 1c sealer shall be applied to all concrete surfaces which are susceptible to deterioration by water and de-icing salts.

The Department standard deck waterproofing system as shown on the Department's Standard Drawing S-1443-98 (see Section 300.5.15.2) shall be used on all bridge decks that come into direct contact with de-icing salts.

Uncoated black steel rebar shall not be used in any bridge deck, curb, sidewalk, median, roof slab, approach, concrete overlay or any other bridge component that will come into direct contact with de-icing salts.

300.5.2.8 Pier Foundations

The Contractor is advised that spread footings shall not be accepted for:

- Piers within stream beds;
- Land-based piers at the outside edge of river bends; or
- Any pier on the banks of highly mobile streams.

300.5.2.9 Sign Structures

Overhead and cantilevered sign structures shall be designed in accordance with the requirements of AASHTO “*Standard Specifications for Structural Supports for Highway Signs, Luminaires and Traffic Signals*” (the “AASHTO Standard Specs”), latest edition plus interims and the following additional criteria:

- Equation 3-1 of AASHTO Clause 3.8.1 shall be modified as follows:

$$P_z = 2.7 q K_z C_d$$

- where q shall be taken from *CAN/CSA S6-00*, Table A3.1.7 for a return period of 50 years;
- The design ice thickness for ice accretion shall be the value given in *CAN/CSA S6-00*, Figure A3.1.4;
- For the design of all cantilevered sign structures, the Fatigue Importance Factors in Table 11-1 of the AASHTO Standard Specs shall be based on Fatigue Category I. The deflection for cantilevered sign structures, as specified in Clause 11.8 of the AASHTO Standard Specs shall not exceed 200 mm;
- Stresses for anchor bolts shall be limited to $0.50F_{pu}$ applied to the root tensile stress area at the Group Load Combination I, II and III. Stress range for Group IV shall be in accordance with Section 11 of the AASHTO Standard Specs. The design shall allow for the failure of one anchor at any one location for each pile foundation. After such failure, the remaining anchors shall still be capable of meeting the above design requirements;
- Anchor bolts shall be pre-tensioned to $0.70 F_{pu}$;
- Design sign panel area shall be taken as the largest of:
 - a) Initial stage sign panels;
 - b) Ultimate Stage sign panels (Ultimate Stage shall consider any potential changes due to safety audits, which changes and audits are the Contractor’s responsibility); and
 - c) Area of 3.5 m x 60% of horizontal span length, placed in any position along the span;
- Sign structures shall have a permanent vertical camber of $L \div 200$ where L is the span of the horizontal arm of the sign structure;

- The tops of the concrete foundations shall project from 700 mm to 850 mm above the adjacent ground surface on the traffic side. The exposed portion of the concrete foundation shall be of circular cross-section; and
- The minimum vertical clearance below the sign panels shall be 6.0 metres.

300.5.2.10 Retaining Wall Structures

Non-mechanically stabilized earth retaining walls shall be designed in accordance with the provisions of *CAN/CSA-S6-00*.

Mechanically stabilized earth (“MSE”) retaining walls shall be designed in accordance with the provisions of *AASHTO LRFD Bridge Design Specifications*, 3rd Edition . However, the load effects applied to the mechanically stabilized walls shall be determined in accordance with *CAN/CSA-S6-00*.

300.5.2.11 Bridge Plaques

Bridge plaques meeting the Department’s requirements shall be attached to all bridge structures.

300.5.2.12 Utility Accommodation

The Contractor shall provide one 100 mm diameter duct in each side of the bridge deck for the future accommodation of utilities. Attachment of utilities to bridge girders or other primary load carrying members shall not be permitted.

300.5.2.13 Clearance Signs

Clearance signs shall be provided on all bridge structures at the locations of underpassing roadways and shall be attached to the upstream fascia girder.

300.5.3 DESIGN REPORT REQUIREMENTS

Prior to initiating construction of a bridge structure, the Contractor shall submit a complete design package for the bridge structure, including *Canada Transportation Act* (“CTA”) applications, approvals and agreements, *Navigable Waters Protection Act* (“NWPA”) drawings, permit applications, approvals, and proof of advertising, Department of Fisheries and Oceans (“DFO”) applications, approvals and orders, design drawings and construction specifications, to the Department. The completed design packages may be submitted in a manner suiting the Contractor’s proposed design and construction schedule. They may also be submitted individually by bridge component, substructure, superstructure or for the complete bridge structure.

Unless otherwise noted, the design package for each bridge structure shall have the following design drawings:

- Design Data (“DD”) Drawings as defined in Appendix J1 of the Department’s *Engineering Consultant Guidelines for Highway and Bridge Projects*.
- Site specific design (P) drawings ⁽¹⁾.
- Applicable standard Department drawings.

Design Data (“DD”) Drawings, including hydrotechnical and geotechnical reports, shall be submitted prior to submission of the site specific Design Drawings. Design Data (“DD”) Drawings are not required for bridge size culverts less than 4.5 m in diameter and for sign structures.

⁽¹⁾ ‘P’ is the designation used in the Department’s bridge drawing record system for all bridge drawings relating to site specific projects. (i.e. 16523-P). These drawing numbers will be assigned by the Department. The ‘P’ designation is changed to a ‘C’ for the as-constructed drawings.

300.5.4 FINAL DESIGN REPORT REQUIREMENTS

Following final completion of the detailed design of a bridge structure, the Contractor shall submit copies of the following documents for the bridge structure, if applicable, to the Department for its bridge structure records system.

- Hydrotechnical report;
- Design notes;
- Design check notes;
- Geotechnical report;
- Corrosion survey report;
- *Canada Transportation Act* (“CTA”) applications, approvals and agreements;
- *Navigable Waters Protection Act* (“NWPA”) drawings, permit applications, approvals, and proof of advertising;
- Department of Fisheries and Oceans (“DFO”) applications, approvals and orders;
- Design Data (“DD”) Drawings, hardcopy and electronic Microstation.dgn format;
- Site specific (P) drawings, hardcopy and electronic Microstation.dgn format; and
- Construction specifications.

300.5.5 CONSTRUCTION REQUIREMENTS

300.5.5.1 General

300.5.5.1.1 Materials

All materials incorporated into the bridge structures for the Project shall be new. Timber materials shall only be used for approach guardrail posts and blocking.

300.5.5.1.2 Existing Reference Documents

The Contractor is advised that the Department has an existing “*Specifications for Bridge Construction*” document that outlines the requirements for the construction of bridge structures. While the provisions of the document are not directly binding for the Project, unless noted otherwise, it is based on the Department’s past experience and best practices and will provide guidance and assistance for the construction of the bridge structures.

300.5.6 CONSTRUCTION CRITERIA

300.5.6.1 Specifications For Bridge Construction

The specifications for bridge structures shall incorporate the following supplemental specifications for bridge structures that incorporate cast-in-place concrete, structural steel, precast concrete units, CSP and SPCSP culverts, post-tensioning and overhead and cantilever sign structures:

300.5.6.1.1 Cast-In-Place Concrete

All cast-in-place concrete proposed for the bridge structures in the Project shall be in accordance with Section 300.5.7 (Cast-In-Place Concrete).

300.5.6.1.2 Structural Steel

All structural steel proposed for the bridge structures in the Project shall be in accordance with Section 300.5.8 (Structural Steel).

300.5.6.1.3 Precast Concrete Units

All precast concrete units proposed for the bridge structures in the Project shall be in accordance with Section 300.5.9 (Precast Concrete Units).

300.5.6.1.4 CSP and SPCSP Structures

All proposed CSP and SPCSP bridge sized culverts in the Project shall be in accordance with Section 300.5.10 (Construction of CSP and SPCSP Structures).

300.5.6.1.5 Intentionally Deleted

300.5.6.1.6 Sign Structures

All proposed overhead and cantilevered sign structures in the Project shall be in accordance with Section 300.5.12 (Sign Structures).

300.5.6.1.7 Piling

All piling proposed for the bridge structures in the Project shall be in accordance with Section 300.5.13 (Piling).

300.5.6.1.8 Reinforcing Steel

All reinforcing steel proposed for the bridge structures in the Project shall be in accordance with Section 300.5.14 (Reinforcing Steel).

300.5.6.1.9 Waterproofing Membrane

All waterproofing membrane proposed for the bridge structures in the Project shall be in accordance with Section 300.5.15 (Waterproofing Membrane).

300.5.6.1.10 Alternatives to Supplemental Specifications

The Department will consider proposed alternatives to the supplemental specifications, in whole or in part, subject to the proposed alternatives being equal to or better than the supplemental specifications in the judgement of the Department.

300.5.7 CAST-IN-PLACE CONCRETE

300.5.7.1 General

This specification includes the quality requirements, the sampling and testing of the materials and concrete, the methods of producing and handling the constituent materials, and the batching, mixing, handling, transporting, placing and curing as outlined, and which constitute good and acceptable construction practice in structural and similar work.

Metric versions are inferred, when available and relevant.

300.5.7.2 Submissions

The following information shall be submitted to the Department by a date that is reasonable having regard to the design and construction process and in any event no later than 21 days after request by the Department, acting reasonably:

- Data showing conformance of the fly ash to the requirements of CSA Standard A23.5 for Type “F” or “CI” fly ash;
- Aluminum content of steel fibres used in Class SF or Modified Class SF concrete;
- Concrete mix design for each type of concrete proposed;
- Concrete trial batch results;
- Concrete cylinder strength test results;
- Concrete placing schedule. The Department shall be advised a minimum of two days prior to placing any concrete;
- Type of machine proposed for grinding of deck, if required;
- Concrete crack measurements in concrete containing silica fume; and
- Concrete core strength results, if required.

300.5.7.3 Reference Drawings (as attached after Section 300.5.7.18.6)

- Standard Concrete Joints S-1411-87
- Standard Construction Joints S-1412-99

300.5.7.4 Materials For Concrete

Concrete shall consist of Portland cement, aggregates, water and admixtures or additives which shall conform to the requirements as specified.

Cement - Normal Portland cement, Type 10, or Sulphate Resistant, Type HS, shall be supplied unless otherwise specified. Cement shall conform to the requirements of CSA Standard A3001-03, Portland Cements.

Water - Water to be used for mixing concrete or mortar shall conform to the requirements of CSA Standard A23.1 and shall be free from injurious amounts of alkali, organic materials or deleterious substances. The Contractor shall not use water from shallow, stagnant or marshy sources.

Aggregates - Fine and coarse aggregates shall conform to the requirements of CSA Standard A23.1 and shall be stockpiled separately.

Admixtures - All admixtures, such as water reducing agents, air entraining agents and superplasticizers shall conform to ASTM C494 and be compatible with all other constituents. The addition of calcium chloride, accelerators and air-reducing agents, will not be permitted. Retarders or set controlling admixtures may be used for concrete specified with corrosion inhibitor.

Silica Fume - Condensed silica fume shall conform to CSA Standard A3000-03 - Cementitious Material Compendium, Type SF, with a SiO₂ content of at least 85%, of a maximum of 10% ignition loss, and no more than 1% SO₃ content.

Air Entraining Agent - Air entraining agent shall be added to all concrete and shall conform to the requirements of ASTM C260.

Steel Fibres - When specified, steel fibres shall be Xorex 1, Wire Mix or equivalent. The fibres shall conform to ASTM A820/A820M-04, Type 1 or 5 and be 50 mm in length with the aluminum content no more than 0.020% by mass when tested in accordance with test method Environmental Protection Agency (EPA) 3050B.

Fly Ash - Concrete containing fly ash as a supplementary cementing material may be used in pipe piles, spread footings, solid pier shafts for river bridges, concretes containing silica fume and when aggregate is assessed to be potentially alkali-silica reactive. The fly ash shall not exceed 30% by mass of cementing materials, however, for High Performance Concrete (HPC) it shall be in accordance with Section 300.5.7.5.2 (e) and (g). All fly ash shall conform to the requirements of CSA Standard A23.5 for Type “F” or “CI” fly ash. Only compatible superplasticizing admixtures and air entraining agents shall be used with the fly ash.

300.5.7.5 Class and Composition Of Concrete

300.5.7.5.1 Class of Concrete

Class of Concrete	Minimum Specified Compressive Strength at 28 Days MPa	Size of Coarse Aggregate mm	Range of Slump mm	Total Air Cont. %	Max. Water/ Cementing materials Ratio
B	25	28 to 5	50 to 70	5 - 8	0.45
Modified C	35	20 to 5	60 to 80	5 - 8	0.42
HPC SF	45	20 to 5	90 to 150	5 - 8	0.38
D	30	14 to 5	50 to 70	5 - 8	0.42
S	20	28 to 5	50 to 70	5 - 8	0.50
Pile	25	28 to 5	100 to 140	5 - 8	0.45

Note:

- The size of coarse aggregate shall be 28 to 5 mm for Modified Class C concrete when used in mass pours such as piers and abutments.
- The requirements for Class SF concrete with steel fibres are the same as for Class SF concrete. Additional requirements are listed in Section 300.5.7.5.2 (Class HPC and Class HPC with Steel Fibres).
- When the thickness of deck overlay concrete is specified as 50 mm or less, the nominal maximum top size of aggregate shall be 14 mm.

300.5.7.5.2 Class HPC and Class HPC with Steel Fibres

- (a) mix shall include silica fume and fly ash as supplementary cementing materials in

- combination with compatible air entraining, water reducing and/or superplasticizing admixtures, as required.
- (b) the gradation limits for the fine aggregate shall conform to CSA Standard A23.1, except that the amount of material finer than 160 μm shall not exceed 5%.
 - (c) coarse aggregate shall conform to CSA Standard A23.1 and the maximum combination of flat and elongated particles (3:1 ratio), as determined by CSA Standard A23.2-13A, shall not exceed 10% of the mass of coarse aggregate.
 - (d) minimum cement content (excluding supplementary cementing materials) shall be 335 kg/m^3 .
 - (e) sum of silica fume and fly ash by mass of cementing materials shall be 17% to 20%.
 - (f) silica fume by mass of cementing materials shall be from 6% to 8%.
 - (g) fly ash by mass of cementing materials shall be 11% to 15%.
 - (h) slump retention of test mix after 45 minutes of batching shall be at least 50% of initial slump. The initial slump of the trial mix shall be measured after an elapsed time from batching of not more than 15 minutes.
 - (i) rapid chloride permeability shall be determined in accordance with ASTM C1202 on laboratory moist cured samples at 28 days. Rapid chloride permeability shall be less than 1000 coulombs for concrete without steel fibres or concrete containing corrosion inhibiting admixtures.
 - (j) an air-void spacing factor shall be determined in accordance with ASTM C457 modified point-count method at 100 times magnification. The average of all tests shall not exceed 230 μm with no single test greater than 260 μm .
 - (k) when Class HPC with steel fibres is specified, it shall contain 60 kg of 50 mm long Xorex 1, or equivalent steel fibre, per cubic metre.
 - (l) the temperature of the centre of the in-situ concrete shall not fall below 10°C or exceed 60°C and the temperature difference between the centre and the surface shall be controlled to within 20°C. In addition, the requirements of Table 18 of CSA A23.1 shall apply.
 - (m) trial batch(es) shall be performed prior to placement of concrete at site to verify that requirements pertaining to compressive strengths at seven and 28 days, rapid chloride permeability at 28 days and air void system parameters of hardened concrete have all been met. The Contractor shall also measure the shrinkage of the trial batch concrete in accordance with ASTM C157 and submit the data to the Department for information purposes.

300.5.7.5.3 Temperature

The temperature of all classes of concrete not containing silica fume shall be between 10°C and 25°C at discharge. Temperature requirements for Class HPC and Class HPC with steel fibres shall be between 10°C and 20°C at discharge.

300.5.7.5.4 Aggregate Tests and Concrete Mix Design

The Contractor shall prepare a concrete mix design for each class of concrete the Contractor proposes. Each mix design shall include the following aggregate analysis:

- Fine and coarse aggregate sieve (CSA 23.2-2A);
- Amount of material finer than 80 µm in aggregate (CSA 23.2-5A);
- Organic impurities in sands for concrete;
- Results of deleterious substances and physical properties of aggregates included in Table 12, CSA Standard A23.1-04;
- Assessment of potential for deleterious alkali-aggregate reactivity (“AAR”) (CSA A23.2-27A);
- Petrographic examination of coarse aggregate for concrete shall be required for Class HPC and Class HPC with steel fibres; and
- Sources of proposed aggregates.

The analysis of the aggregates shall be current and fully represent the material to be used in production. Sampling and testing shall have been done no more than 90 days prior to concrete production. Additional analyses of more recent sampling shall be provided periodically to confirm that the aggregates continue to meet requirements. A break in production of a particular class of concrete shall not constitute the need for additional testing when the Contractor provides conclusive evidence that the material initially tested is still representative.

If the fine aggregate consists of a blend from more than one source, the "Fine Aggregate Sieve" analysis shall show the gradation of the blended fine aggregates. Similarly in the case of blended coarse aggregates, the "Coarse Aggregate Sieve" analysis shall indicate the gradation of the blended coarse aggregates.

Fine aggregate, tested in accordance with CSA Standard A23.2-7A, “*Organic Impurities in Sands for Concrete*”, shall produce a colour not darker than the Standard colour (Organic Plate Number 3). Aggregate producing a colour darker than the Standard colour will be rejected in the absence of a satisfactory record of performance of a similar class of concrete (minimum 30 tests over the last 12 months); provisions 4.2.3.3.2 (a) and (b) of CSA Standard CAN3-A23.1-04 shall not apply.

The potential for deleterious alkali-aggregate reactivity shall be assessed in accordance with CSA Standard A23.2-27A. This assessment shall include the risk level associated with structure size and environment, the level of prevention related to service life requirements and the determination of the appropriate preventative measures. Current (less than 18 months old) test data evaluating the potential alkali-silica reactivity of aggregates tested in accordance with CSA

Standard A23.2-14A or CSA Standard A23.2-25A is required. In the absence of current test data and outside of areas of known highly reactive aggregate, the aggregate shall be presumed to be moderately reactive.

Petrographic analysis shall be performed by an experienced qualified petrographer of a CSA certified laboratory in accordance with CSA A23.2-15A. The (weighted) petrographic number shall not exceed 130, and the ironstone content shall not exceed 0.8%. The results shall be certified by a professional geologist, or a geological engineer and indicate that the aggregate is suitable for the intended use.

Concrete mixes that will be placed by concrete pump shall be designed for pumping.

The sampling and testing of aggregates, and the concrete mix design shall be completed by an independent CSA certified and qualified concrete testing laboratory which shall have a permit to practice in the Province of Alberta. Concrete mix designs including sampling and testing of aggregates may be completed and stamped by a Professional Engineer; however for these situations, the mix design shall be reviewed and stamped by an independent CSA certified and qualified concrete testing laboratory having a permit to practice in the Province of Alberta. For either case, the testing laboratory shall provide an engineering opinion that the concrete aggregate and mix designs are suitable for the intended use and are expected to perform to specified standards.

For Class HPC and Class HPC with steel fibres the Contractor shall produce evidence that the proportions selected will produce concrete of the quality specified. This shall include the preparation of satisfactory trial mixes before the concrete is used. The trial mix shall be a minimum of 3 m³ or 50% of the rated mixer capacity (whichever is greater) and simulate the anticipated placing procedures at site. In preparing the trial mixes, the workability and slump retention characteristics shall be assessed at 30, 45 and 60 minute intervals. In addition the concrete from the trial mixes shall also satisfy the rapid chloride permeability requirements in accordance with Section 300.5.7.5.2 (Class HPC and Class HPC with Steel Fibres).

300.5.7.5.5 Initial Mixes and Adjustments

For all classes of concrete other than HPC and HPC with steel fibres, in cases of initial mixing operations or changes in source of water or aggregate, the mix adopted shall be designed for an excess compressive strength of 10% above the specified 28 day nominal compressive strength. After the mix has been adequately proven as to strength and performance, adjustment may be undertaken, but only with the acceptance of the Department. If, during the progress of the work, the mix design is found to be unsatisfactory for any reason including poor workability, the Contractor shall make the necessary adjustments. Notwithstanding the Department's review of the mix design, it remains the Contractor's responsibility that the concrete meets all the requirements of the Technical Requirements.

300.5.7.6 Mixing Concrete

Mobile continuous mixers or other such concrete supply equipment will not be accepted for use.

300.5.7.6.1 Truck Mixing

Truck mixers shall be of the revolving drum type, watertight, and so constructed that the concrete can be mixed to ensure uniform distribution of materials throughout the mass. All materials for the concrete shall be accurately measured and charged concurrently at the proportions which satisfy the approved mix design into the drum at the production plant. Increases in water-cement ratio will not be permitted.

The maximum size of batch in truck mixers shall not exceed the maximum rated capacity of the mixer as stated by the manufacturer and stamped in metal on the mixer. Truck mixing shall commence immediately upon introduction of ingredients into the drum and be continued for not less than 50 revolutions, with the mixing rate being in accordance with the manufacturer's recommended rate, and shall be such as to thoroughly mix the concrete.

When adjustment to the mix by adding air entraining agent or superplasticizer at the site is made, the mixer shall be run for a minimum of 20 additional revolutions to ensure homogeneity of the concrete before discharge. Discharge chutes shall be kept clean and free from hardened concrete and shall be wetted down prior to use.

300.5.7.6.2 Time of Hauling

The maximum time allowed for all classes of concrete other than Class HPC and Class HPC with steel fibres including delivery to the site of the work and discharge shall not exceed 90 minutes after batching. Batching of all classes of concrete is considered to occur when any of the mix ingredients are introduced into the truck mixer drum, regardless of whether or not the drum is revolved. For Class HPC and Class HPC with steel fibres this requirement is reduced to 70 minutes. In hot weather, or under conditions contributing to quick setting of the concrete, a reduction in these times may be required.

300.5.7.6.3 Delivery

The concrete supplier shall have sufficient plant capacity and satisfactory transporting equipment to ensure continuous delivery at the rate required. The rate of delivery of concrete during concreting operations shall be such that cold joints will not develop. The methods of delivering and handling the concrete shall facilitate placing with a minimum of rehandling, and without damage to the structure or the concrete.

300.5.7.7 Inspection and Testing

The Department shall be afforded full access for any inspections that it may carry out relative to the concrete itself and/or the constituent materials. This includes at the worksite and any plant

used for the manufacture of concrete wherever this may be situated. The access shall be adequate to permit proper sampling of concrete, making of test cylinders and testing slump and air content. The proper storage of all site cast concrete cylinders, including cylinders cast by the Department, in accordance with the relevant specifications is the responsibility of the Contractor and shall be provided prior to any concrete pour.

The results of the testing carried out by the Department will serve to monitor the quality assurance and quality control program of the Contractor.

The Contractor shall utilize ACI or CSA certified testers with extensive related experience to test at site, the air content, slump and temperature of each batch. Additional tests will be required if the results are borderline or widely variable. In case of an unacceptable result, one check test will be permitted. The certified testers shall also cast the test cylinders as specified in Section 300.5.7.7.3 (Test Cylinders).

300.5.7.7.1 Strength Tests

A “Strength Test” shall consist of the compression tests of four standard test specimens, sampled, made, cured, and tested in accordance with CSA Standard Specifications as referenced with modifications as indicated. One cylinder shall be tested at seven days. The 28 day test result shall be the average of the strengths of the remaining three specimens, except that if any specimens in a test showing distinct evidence of improper sampling, molding or testing, shall be discarded and the remaining strengths averaged. Additional cylinders may be cast, at the discretion of the Contractor.

For Class HPC and Class HPC with steel fibres the Contractor shall take a strength test to represent each approximate 10 m³ portion of the concrete pour. For all other concrete, the Contractor shall take a strength test to represent each bridge element or portion of the element (i.e. abutment seat, abutment backwall, pier footing, pier cap), except on larger pours a strength test will be taken to represent each approximately 30 m³ portion of the concrete pour. Such tests shall be taken from representative batches.

300.5.7.7.2 Sampling

Sampling of concrete shall be carried out in accordance with CSA Standard A23.2-1C.

When a concrete pump is used to place concrete, sampling shall be at the end of the discharge hose.

300.5.7.7.3 Test Cylinders

Making and curing concrete test cylinders shall be carried out in accordance with CSA Standard A23.2-3C, except that the time for cylinders to reach the testing laboratory shall be between 20 and 48 hours. The test cylinders shall be cast by the Contractor in standard CSA approved moulds. The Contractor shall provide properly designed temperature-controlled storage boxes for test cylinders, as specified in Section 5.3.2.1 of CSA Standard A23.2-3C for a period of at

least 24 hours and further protection, from adverse weather and mishandling until removed from the site. The Contractor shall provide a max-min thermometer for each storage box and record site curing temperatures for all test cylinders. Storage in a portable building which will be used by Contractor's personnel or the Department during the first 24 hour storage period will not be permitted. Storage facilities shall be provided, installed, and approved before any concrete is placed. The Contractor shall be responsible to deliver the test cylinders to an independent CSA certified testing laboratory.

Handling and transporting of the cylinders shall be in accordance with CSA Standard 23.2-3C. No extra laboratory curing time will be allowed for cylinders that are delivered late to the laboratory.

If the test cylinders exhibit frozen conditions or are otherwise mishandled resulting in unreliable strength test results, the Department may reject these portions of the work unless core-testing, at the Contractor's expense confirms the in-situ strength of the concrete.

Testing carried out by the Department including costs for breaking and provision of concrete test cylinder reports will be paid for by the Department.

300.5.7.7.4 Slump

Slump tests shall be made in accordance with CSA Standard A23.2-5C.

300.5.7.7.5 Air Content

Air content tests shall be made in accordance with CSA Standard A23.2- 4C.

300.5.7.7.6 Testing Cylinders

Test cylinders will be tested in compression in accordance with CSA Standard A23.2 by an independent CSA certified testing laboratory engaged by the Contractor.

300.5.7.7.7 Failure to Meet Slump or Air Content Specifications

The Contractor will be allowed to adjust only the quantities of superplasticizer and air entraining agent at site. The Department reserves the right to reject any batch in the event of confirmed unacceptability, and to require immediate removal of any concrete from this batch which may have already been placed in the structure.

300.5.7.8 Falsework and Formwork

300.5.7.8.1 General

All falsework and formwork drawings shall be prepared and sealed by a Professional Engineer. After installation the engineer shall inspect the falsework and/or formwork to confirm that it is in

conformance with the design and drawings. All formwork shall be removed from the completed structure.

300.5.7.8.2 Standard Details

Refer to Standard Drawing S-1411-87 “Standard Concrete Joints” and Standard Drawing S-1412-99 “Standard Construction Joints,” attached after Section 300.5.7.18.6, for details of joints.

300.5.7.8.3 Deck Formwork

Prior to commencing deck formwork, the Contractor shall profile all the girders and determine the deck concrete thickness values required to achieve the specified grade line.

In the event that actual girder camber values vary significantly from the estimated values indicated on the drawings, the Contractor may raise or lower the grade line accordingly.

300.5.7.9 Handling and Placing Concrete

300.5.7.9.1 General

All the necessary equipment for any particular pour shall be on site and proven to be in working condition before the pour commences, with backup equipment on site. The equipment shall be well maintained, suitable in kind and adequate in capacity for the work.

In preparation for the placing of concrete, all sawdust, chips and other construction debris and extraneous matter shall be removed from the interior of forms. Struts, stays, and braces, serving temporarily to hold the forms in correct shape and alignment, pending the placing of concrete at their locations, shall be removed when the concrete placing has reached an elevation rendering their service unnecessary. These temporary members shall be entirely removed from the forms and not buried in the concrete.

300.5.7.9.2 Consolidation

Concrete, during and immediately after depositing, shall be thoroughly consolidated. The consolidation shall be done by mechanical vibration.

300.5.7.9.3 Additional Requirements

When concrete placing is discontinued, for whatever reason, all accumulations of mortar splashed on the reinforcing steel and the form surfaces shall be removed. Dried mortar chips and dust shall not be puddled into the unset concrete. If the accumulations are not removed prior to the concrete becoming set, care shall be exercised not to injure or break the concrete-steel bond at and near the surface of the concrete, while cleaning the reinforcing steel.

Concrete shall be placed while fresh and before it has taken its initial set. Retempering of partially hardened concrete with additional water will not be permitted. No concrete shall be used which does not reach its final position in the forms within the time stipulated under Section 300.5.7.6.2 (Time of Hauling) above.

After initial set of the concrete, the forms shall not be jarred and no strain shall be placed on the ends of reinforcing bars which project.

Concrete which would be adversely affected by the presence of freestanding water shall be protected to prevent its occurrence, and the Contractor shall take whatever steps may be necessary to prevent free water build-up in the event of unexpected rainfall or similar occurrences for the first 24 hours.

Water used to keep equipment clean during the pour, or to clean equipment at the end of the pour, shall be discharged clear of the structure.

300.5.7.9.4 Pumping

The operation of the pump shall produce a continuous flow of concrete without air pockets. The equipment shall be so arranged that no vibrations result which might damage freshly placed concrete. When pumping is completed, the concrete remaining in the pipeline, if it is to be used, shall be ejected in such a manner that there will be no contamination of the concrete or separation of the ingredients.

300.5.7.10 Placing Pile Concrete

300.5.7.10.1 General

The Contractor shall make every attempt to obtain a “Dry” pile hole prior to placing pile concrete. The placement of pile concrete under water will only be permitted in the event that all reasonable attempts at obtaining a dry hole fail.

300.5.7.10.2 Concrete Placed in the Dry

Pile concrete shall be placed by means of a hopper equipped with a centre pipe drop tube. The pipe drop tube shall be a minimum of 200 mm in diameter and 2 m long. Concrete may be placed free fall, providing the fall is vertically down the centre of the casing or drilled hole and there are no transverse ties or spacers. Pile concrete shall have a slump range of 100 - 140 mm at time of discharge. Concrete in the upper 3 m of the piles shall be consolidated by the use of an approved concrete vibrator.

300.5.7.10.3 Concrete Placed Under Water

Placement of pile concrete under water shall be in accordance with Section 300.5.7.14 (Depositing Concrete Under Water) of this specification.

300.5.7.11 Placing Deck, Curb and Deck Overlay Concrete

300.5.7.11.1 General

Concrete placing will not be permitted when the air temperature is below +5°C or above 22°C, nor in the event of rain or excessive wind or dust, nor when there are other conditions detrimental to the concrete. Deck concrete placing shall normally be between the hours of 1800 and 1000 the following day. Night pours shall require proper lighting. The temperature of the concrete during discharge shall be between 10°C and 20°C. The temperature of the mix shall be maintained below the 20°C maximum temperature by the inclusion of ice to the mix which shall not alter the design water-cement ratio. Immediately prior to placing concrete, the substrates shall be thoroughly wetted down with clean water.

All deck concrete and deck overlay concrete shall be consolidated in accordance with Section 300.5.7.9.2 (Consolidation) even when vibratory drum type finishing machines are used.

300.5.7.11.2 Placing/Finishing Machines

For all deck concrete and deck overlay concrete, screeding shall be by concrete placing/finishing machines as follows or equivalents:

- Bidwell Model RF200 or Model 364;
- Gomaco Model C450.

The Contractor shall provide two work bridges, separate from the placing/finishing machine, of adequate length to completely span the width of the pour. The work bridges will facilitate the operations of concrete finishing and placing of wet burlap, and shall also be made available to the Department for review. The work bridges shall be supported essentially parallel to the concrete surface, between 250 mm and 600 mm above the concrete surface, and shall be at least 800 mm wide to permit diverse uses concurrently, and be rigid enough that dynamic deflections are insignificant.

300.5.7.11.3 Screed Guide Rails

Steel screed guide rails shall be installed to suit the profile of the required surface and to ensure a smooth and continuous surface from end to end of the bridge. Guide rails must be located outside of the finished surface of the pour for overlay concrete and also for deck concrete, unless specified otherwise in the design drawings. All rails and supports shall be removed with minimum disturbance to the concrete.

300.5.7.11.4 Dry-Run

The finishing machine shall be set-up to match the skew angle of the bridge, when the skew angle exceeds 15 °. For skewed bridge structures on vertical curves, this requirement may be altered to suit actual site conditions.

The finishing machine and guide rails shall be adjusted so that the height of the screed will finish the concrete to the design grade line and crown. To confirm the adjustment of the machine and guiderails, the screed shall be dry-run prior to the pour and clearance measurements taken at each of the girder tenth points. Re-setting of the machine and/or screed rails shall be done as necessary, to obtain an acceptable dry-run. Adjustments to the machine or screed rails will not be permitted after an acceptable dry-run has been completed.

Where screed rails are supported on cantilevered formwork that could deflect under the weight of the fresh concrete and the deck finishing machine, the Contractor shall pre-load a section of the cantilevered formwork on each side of the bridge to determine deflections that will occur during concrete placement. The formwork, machine and/or screed rails shall be adjusted to compensate for the expected formwork deflection.

300.5.7.11.5 Fog Misting and Wet Cure Systems

The Contractor shall prepare details of the fog misting and wet cure systems. Details shall include information with regards to the type and description of equipment and materials being used and work method/techniques employed to satisfactorily carry out the work.

300.5.7.11.6 Surface Defects and Tolerances

The finished surface of the concrete shall conform to the design grade line profiles as indicated on the drawings and/or as determined on site.

The surface shall be free from open texturing, plucked aggregate and local projections.

Except across the crown, the surface shall be such that when tested with a 3 m long straight edge placed anywhere in any direction on the surface, there shall not be a gap greater than 3 mm between the bottom of the straight edge and the surface of the deck anywhere below the straight edge.

The surface shall be checked by the Contractor, as described above, immediately after final bull floating and before texturing.

The surface shall again be checked by the Contractor at the end of the curing period in the same manner and to the same tolerance.

Areas that do not meet the required surface accuracy shall be clearly marked out and the Contractor shall:

- (a) Grind down any areas higher than 3 mm but not higher than 10 mm above the correct surface.
- (b) Correct any areas lower than 3 mm but not lower than 10 mm below the correct surface, by grinding down the adjacent high areas.
- (c) When the deviation exceeds 10 mm from the correct surface, the deck slab shall be replaced for a length, width and depth which will allow the formation of a new slab, of the required quality, in no way inferior to the adjacent undisturbed slab.

Grinding shall be carried out by a machine, of a type and capacity suitable for the total area of grinding involved, until the surface meets the specified requirements.

300.5.7.12 Construction Joints

300.5.7.12.1 General

Construction joints shall be made only where indicated on the drawings or shown in the pouring schedule.

If not detailed on the drawings, or in the case of emergency, construction joints shall be placed according to the standard drawing. Shear keys or inclined reinforcement shall be used where necessary to transmit shear, or to bond the two sections together. Construction joints should be located to allow a minimum of 50 mm minimum concrete cover on reinforcing steel running parallel to the joint. Refer to Standard Drawing S-1412-99 “Standard Construction Joints” attached after Section 300.5.7.18.6.

300.5.7.13 Concreting In Cold Weather

The Contractor shall accept full responsibility for the protection of concrete during adverse weather conditions.

When the ambient air temperature is, or is expected to be, below 5°C the following provisions for cold weather concreting shall be put in place:

- (1) All aggregate and mixing water shall be heated to a temperature of at least 20°C but not more than 65°C. The aggregates may be heated by either dry heat or steam; in the latter case the quantity of mixing water may need to be reduced. The temperature of the concrete shall be between 10°C and 25°C at the time of placing in the forms.
- (2) The Contractor shall enclose the structure in such a way that the concrete and air within the enclosure can be kept above 15°C for a period of seven days after placing the concrete. The enclosure shall be constructed so that a minimum 300 mm clearance exists

between the enclosure and the concrete. To prevent overheating, the air temperature within the enclosure shall be monitored frequently, especially during the first 24 hours.

The system of heating, and positioning of steam outlets, heaters, and fans, is to be designed to give the most uniform distribution of heat possible.

- (3) Before placing concrete, adequate pre-heat shall be provided to raise the temperature of formwork, reinforcing steel, previously-placed concrete, and/or soil to at least 10°C. The Contractor shall be responsible to make all arrangements for heating, and to ensure continuous protection from unsatisfactory temperature and moisture conditions during the curing period. The pre-heat shall be adequate to ensure that no portion of the fresh concrete is damaged by freezing, or curing retarded by cold temperatures.
- (4) Protection and heating, where used, shall be withdrawn in such a manner so as not to induce thermal shock stresses in the concrete. The temperature of the concrete shall be gradually reduced at a rate not exceeding 10°C per day to that of the surrounding air. To achieve this, in a heated housing, the heat shall be slowly reduced and then shut off, and the whole housing allowed to cool to air temperature before the housing itself is removed. However, the protection shall not be removed until the temperature of the concrete has fallen to within 10°C of the temperature of the outside air.

300.5.7.14 Depositing Concrete Under Water

Concrete shall not be deposited in water except as specified, in which case anti-washout admixtures incorporating viscosity modifiers (whelan gum, etc.) may be used.

Concrete to be deposited in water shall be of the specified class, with mix design modified to yield 150 mm to 175 mm slump, and with an excess of 15% of the cement quantity added beyond its normal designed amount. The mix should contain an approved “anti-washout” admixture to enhance the performance of the mix. The concrete temperature shall be between 10°C and 25°C.

Concrete shall not be placed in water which is below 4°C.

The surface of the concrete shall be kept as nearly horizontal as is practicable at all times. The discharge end of the tremie shall be kept buried at least 0.3 m in previously placed concrete.

Dewatering will not be permitted while concrete is being placed. Dewatering may proceed when the concrete seal is sufficiently hard and strong. All laitance or other unsatisfactory material shall be removed from the exposed surface by scraping, chipping or other means which will not injure the surface of the concrete.

300.5.7.15 Curing Concrete

300.5.7.15.1 General

Freshly deposited concrete shall be protected from freezing, abnormally high temperatures or temperature differentials, premature drying, excessive moisture, and moisture loss for the period of time necessary to develop the desired properties of the concrete.

All exposed concrete surfaces, other than Class HPC and Class HPC with steel fibres, which are to receive a Class 2 or 3 finish, shall be moist cured. The Contractor shall cover the concrete surface(s) with a single layer of clean, soaking wet burlap or light coloured filter fabric as soon as the surface will not be marred by so doing. The burlap or light coloured filter fabric shall be kept continuously wet for 72 hours.

All unexposed concrete surfaces not requiring the application of silane sealer shall receive two applications of a curing compound. The rate of each application shall not be less than the rate specified by the manufacturer of the compound. Curing compound shall not be used on any construction joints or when cold weather concreting is in effect.

Where the formwork is left in place for 72 hours or more, no additional curing will be required for either exposed or unexposed concrete surfaces.

300.5.7.15.2 Curing Requirements for Concrete Slope Protection

Concrete slope protection shall receive two coats of a curing compound. The first coat is to be applied immediately after the concrete has been satisfactorily finished, and the second coat is to be applied within three hours after the application of the first coat. In cases where premature drying is severe or is anticipated to be severe, then moist curing, as specified in Section 300.5.7.15.1 (Curing Concrete – General), will also be required.

300.5.7.15.3 Curing Requirements for Class HPC and Class HPC with Steel Fibres

For Class HPC or Class HPC with steel fibres, fog mist shall be applied continuously from the time of screeding until concrete is covered with filter fabric or burlap, in such a way as to maintain high relative humidity above the concrete and prevent drying of the concrete surface. Water shall not be allowed to drip, flow or puddle on the concrete surface during fog misting, when placing the filter fabric or burlap or at any time before the concrete has achieved final set. Equipment and materials necessary for the fog mist system shall be acceptably demonstrated prior to scheduling and placing of Class HPC concrete.

Two layers of light coloured filter fabric (Nilex C-14 or equivalent) or burlap shall be placed on the fresh concrete surface as soon as the surface will not be marred as a result of this placement. A fine spray of water shall be immediately applied to the filter fabric or burlap. Edges of the filter fabric or burlap shall overlap a minimum of 150 mm and shall be held in place without marring the surface of the concrete.

The filter fabric or burlap shall be in a continuously wet condition throughout the curing period, by means of a soaker hose or other means. Curing with filter fabric or burlap and water shall be maintained for a minimum period of 14 days, with the exception of concrete for blockouts adjacent to deck joints, where the wet cure period is reduced to three days followed by the application of a chlorinated rubber curing compound.

During the cure period for Class HPC and Class HPC with steel fibres, the Contractor shall provide protection to ensure that the concrete temperature and the temperature differences remain within the limits specified in Sections 300.5.7.5.2(1) or 300.5.7.5.3 respectively. The Contractor shall supply and install two thermocouplers, in the centre and at the surface of the concrete, for every 100 m² of deck. The Contractor shall monitor and record the temperatures every four hours for the first three days after concrete placement and every 12 hours thereafter during remaining curing period.

300.5.7.15.4 Class HPC and Class HPC with Steel Fibres

After the curing period and before Traffic Availability, the Contractor shall inspect the dry concrete surface(s) to identify all cracks. The width in millimetre and length in linear metres of cracks per square metre will be plotted by the Contractor. The Contractor shall repair the cracks at its own expense if crack width exceeds 0.2 mm. The following procedure shall be used in the treatment of same:

- (a) Blow out cracks clean and dry with a jet of oil-free compressed air.
- (b) Seal cracks with a gravity feed epoxy in accordance with the manufacturer's instructions. The gravity feed epoxy shall maximize the penetration by taking into consideration the ambient temperature, the substrate temperature, the viscosity and pot life of the material being used. Gravity feed epoxy material shall be reviewed by the Department prior to its usage.
- (c) When cracks extend the full depth of the deck slab or to the top layer of reinforcement of decks that are cast to grade, epoxy injection will be required. The epoxy material and injection procedure shall be submitted by the Contractor to the Department for prior written approval.

300.5.7.16 Concrete Surface Finish

300.5.7.16.1 General

Surfaces requiring concrete finishing, shall conform to the requirements of Section 300.5.7.11.6 (Surface Defects and Tolerances). All mortar patches shall be cured as specified in Section 300.5.7.15 (Curing Concrete).

On unexposed concrete surfaces all cavities, honeycomb, and other deficiencies shall be thoroughly chipped out, cleaned, and after having been kept saturated with water for a period of not less than 30 minutes, shall be filled with cement mortar.

On exposed concrete surfaces to 600 mm below grade or, in the case of river piers, 600 mm below lowest water level, surface finishes shall be applied as follows:

Class 1 Ordinary Finish

- all exposed concrete surfaces unless other finishes are specified.

Class 2 Rubbed Finish

- solid shaft river piers;
- inside surfaces of curb, parapet and sidewalk; and
- median vertical faces.

Class 3 Bonded Concrete Finish

- abutment seats except top surface;
- pier caps except top surface;
- exterior faces of curtain walls/wingwalls;
- grade separation piers except top surfaces;
- exterior concrete girder faces;
- exposed end surfaces of cast-in-place concrete diaphragms;
- underside of the deck overhang to top flange of girder; and
- exterior surfaces of curb, parapet and sidewalk.

Class 4 Floated Finish

- top surfaces of concrete deck and roof slabs which are to receive waterproofing membranes and wearing surfaces.

Class 5 Floated Surface Finish, Broomed Texture

- top surfaces of curbs, sidewalks, and medians;
- approach slab concrete which will be covered by a wearing surface only (without waterproofing membrane); and
- concrete slope protection.

Class 6 Floated Finish, Surface Textured

- top surfaces of deck, roof and approach slabs which will not be covered with either waterproofing membrane or wearing surface.

Only approved wood or magnesium floats shall be used for finishing concrete.

300.5.7.16.2 Class 1. Ordinary Surface Finish

Unformed Surfaces - Immediately following placing and compacting, the concrete shall be screeded to conform to the required surface elevations, and then trowelled to ensure that the surface is free from open texturing, plucked aggregate, and local projections or depressions.

Formed Surfaces - Immediately following the removal of forms, all fins and irregular projections shall be removed from all surfaces. On all surfaces the cavities produced by form ties, and all other holes, honeycomb areas, broken corners or edges and other defects, shall be thoroughly chipped out, cleaned, and after having been kept saturated with water for a period of not less than 30 minutes, shall be filled with cement mortar. Mortar shall be not more than one hour old. The mortar patches shall be cured as specified under Section 300.5.7.15 (Curing Concrete). All concrete joints in the completed work shall be left carefully tooled and free of all mortar and concrete. The joint filler shall be left exposed for its full length with clean and true edges.

300.5.7.16.3 Class 2. Rubbed Finish

Immediately following the removal of forms, all fins and irregular projections shall be removed from all surfaces. All lines that are not true must be corrected by chipping, grinding or patching as necessary. Parging to correct irregularities will not be permitted. On all surfaces, the cavities produced by form ties, air bubbles and all other holes, honeycomb areas, broken corners or edges and other defects, shall be thoroughly exposed by wire brushing with a stiff bristled, powered, wire brush. The cleaned surface, after having been kept saturated with water for a period of not less than 30 minutes, shall be filled with cement mortar. Mortar shall be not more than one hour old. The mortar patches shall be cured as specified under Section 300.5.7.15 (Curing Concrete). All concrete joints in the completed work shall be left carefully tooled and free of all mortar and concrete. The joint filler shall be left exposed for its full length with clean and true edges. The small surface voids formed by air bubbles must be filled by rubbing a thin grout composed of bonding agent, water, clean fine sand and cement into the moistened surface. When the patching and filling have adequately hardened, a carborundum stone shall be used to finish the surface to a smooth, uniform and closed texture. Any voids opened during the stone rubbing process shall be refilled.

It is essential that the prepared concrete surface, including all patching and filling be uniform in colour and texture. All portions of bridge elements, including those cast in more than one pour, shall be of the same colour and texture. Any staining caused by cement, water, weather, or other conditions shall be prevented, removed, or covered. After the surface preparation has been completed the Contractor shall apply sealer as specified in Section 300.5.7.17 (Sealer).

If uniformity of colour is not achieved the Contractor, rather than applying the sealer as specified in Section 300.5.7.17 (Sealer), shall supply and apply an approved pigmented concrete sealer as specified for Section 300.5.7.16.4 (Class 3. Bonded Concrete Surface Finish).

300.5.7.16.4 Class 3. Bonded Concrete Surface Finish

Surface preparation shall be done as is specified for Section 300.5.7.16.3 (Class 2. Rubbed Finish), except that uniformity in colour is not required.

After the surface preparation has been completed the Contractor shall then supply and apply a pigmented concrete sealer, which meets the requirements for a Type 3 sealer in Alberta Transportation's "*Specifications for Concrete Sealers*" (B388).

The pigmented concrete sealer shall be applied in accordance with the manufacturer's specifications. The colour of the proposed coating shall be as specified in the design. A minimum of two applications of the pigmented sealer are required. The Contractor shall ensure that no colour variation is visible, and shall match the colour of any previously painted adjoining surfaces.

300.5.7.16.5 Class 4. Floated Surface Finish

Unless otherwise noted on the drawings, concrete which is to receive a waterproofing membrane and a final wearing surface, shall be floated and trowelled as necessary to provide a smoothly textured surface.

300.5.7.16.6 Class 5. Floated Surface Finish, Broomed Texture

The concrete surface shall be floated and trowelled as necessary to produce a smooth surface. The surface shall not vary more than 3 mm under a 3 m long straightedge.

After the concrete has set sufficiently, the surface shall be given a transversely broomed finish using a coarse broom to produce regular corrugations to a maximum depth of 3 mm. An edging tool shall be used at all edges and expansion joints. Where indicated on the drawing, sidewalk surfaces shall be laid out in blocks using an approved grooving tool.

300.5.7.16.7 Class 6. Floated Finish, Surface Textured

After the concrete has been bull floated, it shall be given a suitable texture with a “flat wire” texture broom having a single row of tines. The desired texture is transverse grooving which may vary from 1.5 mm width at 10 mm centres to 5 mm width at 20 mm centres, and the groove depth shall be 3 mm to 5 mm. This operation shall be done at such time and in such manner that the desired texture will be achieved while minimizing the displacement of the larger aggregate particles or steel fibres. The textured surface shall be uniform and consistent.

Following the surface texturing, a strip of the concrete along the inside curb line, shall be trowelled smooth and the surface left closed.

300.5.7.17 Sealer

An approved Type 1c sealer shall be applied to all concrete surfaces which are susceptible to deterioration by water and de-icing salts. This shall include all concrete surfaces to 600 mm below grade, or in the case of river piers 600 mm below lowest water level, or as specified and shall include all surfaces which are to receive a Class 2, Class 5 and Class 6 Finish. This does not apply to surfaces covered with waterproofing membrane and ACP wearing surface, drain troughs and concrete slope protection. Sealer will not be required on the underside of bridge decks and on concrete diaphragms in the interior bay areas, however the faces of the end diaphragms

nearest the abutment backwalls, inside faces of backwalls, top surface of abutment seats, excluding bearing recess pockets, and the deck and curb overhangs shall be sealed.

Type 1c sealers shall meet Alberta Transportation’s current “*Specifications for the Supply of Concrete Sealers - Evaluation Procedures for Sealers Used on Concrete Bridge Elements*” (B388).

The sealer shall be applied in accordance with the manufacturer's recommendations, however, the application rate shall be increased by 30% from that indicated on the approval list. Before applying the sealer the concrete shall be cured for at least 14 days. Mortar patches shall be cured for at least two days. The concrete surface shall be dry, and air blasted to remove all dust prior to applying sealer. In order to ensure uniform and sufficient coverage rates the Contractor shall apply measured volumes of sealing compound to appropriately dimensioned areas of concrete surface, using a minimum of two coats.

300.5.7.18 Concrete Strength Requirements

The Department reserves the right to reject any concrete whatsoever which does not meet all the requirements for that class of concrete as stated in Section 300.5.7.5 (Class and Composition Of Concrete). However, provided that the Contractor’s Engineer is of the opinion that the low strength concrete will meet all performance requirements throughout the life of the New Infrastructure, the Department may, in its sole discretion, accept concrete the strength of which falls below the specified strength requirements.

Payment Adjustments will be made in accordance with the following:

300.5.7.18.1 Class B Concrete, Pile Concrete, 25 MPa

Strength Test Results

24 MPa to 25 MPa	\$15 per cubic metre
23 MPa to 24 MPa	\$30 per cubic metre
22 MPa to 23 MPa	\$45 per cubic metre
21 MPa to 22 MPa	\$60 per cubic metre
20 MPa to 21 MPa	\$80 per cubic metre

300.5.7.18.2 Class D Concrete, 30 MPa

Strength Test Results

29 MPa to 30 MPa	\$15 per cubic metre
28 MPa to 29 MPa	\$30 per cubic metre
27 MPa to 28 MPa	\$45 per cubic metre
26 MPa to 27 MPa	\$60 per cubic metre

25 MPa to 26 MPa	\$80 per cubic metre
24 MPa to 25 MPa	\$110 per cubic metre

300.5.7.18.3 Modified Class C Concrete, 35 MPa

Strength Test Results

34 MPa to 35 MPa	\$15 per cubic metre
33 MPa to 34 MPa	\$30 per cubic metre
32 MPa to 33 MPa	\$45 per cubic metre
31 MPa to 32 MPa	\$ 60 per cubic metre
30 MPa to 31 MPa	\$80 per cubic metre
29 MPa to 30 MPa	\$110 per cubic metre
28 MPa to 29 MPa	\$150 per cubic metre
27 MPa to 28 MPa	\$200 per cubic metre

300.5.7.18.4 Class HPC Concrete, 45 MPa

Strength Test Results

44 MPa to 45 MPa	\$20 per cubic metre
43 MPa to 44 MPa	\$40 per cubic metre
42 MPa to 43 MPa	\$60 per cubic metre
41 MPa to 42 MPa	\$80 per cubic metre
40 MPa to 41 MPa	\$100 per cubic metre
39 MPa to 40 MPa	\$130 per cubic metre
38 MPa to 39 MPa	\$180 per cubic metre
37 MPa to 38 MPa	\$240 per cubic metre

300.5.7.18.5 Class S Concrete, 20 MPa

Strength Test Results

18 MPa to 20 MPa	\$15 per cubic metre
16 MPa to 18 MPa	\$35 per cubic metre

The Payment Adjustments shall apply to the volume of concrete represented by the Strength Test as defined in Section 300.5.7.7.1 (Strength Tests).

Concrete with strengths below the scales shown;

- i.e.
- Class B and Pile concrete below 20 MPa
 - Class D concrete below 24 MPa
 - Modified Class C concrete below 27 MPa
 - Class HPC concrete below 37 MPa
 - Class S concrete below 16 MPa

are not acceptable to the Department.

If the minimum specified design strength for a class of concrete is increased above the design strength shown in Section 300.5.7.5 (Class and Composition Of Concrete) then the Payment Adjustment strength ranges shown in this Section 300.5.7.18 shall be increased by the same amount.

300.5.7.18.6 Coring for Compressive Strength Testing

Coring to confirm or contest low concrete Strength Test results shall be subject to approval by the Department. When coring is approved, arrangements shall be made by the Contractor, to employ a CSA Category 1 or higher level certified testing laboratory, all at the expense of the Contractor. The cores shall be taken and tested within seven days of the testing of the 28 day cylinders representing the concrete in question. Where practical, three 100 mm diameter cores shall be taken for each non-compliant Strength Test previously taken, and there shall be no doubt that the cores taken and the cylinders under consideration, represent the same batch of concrete. Cores may not be taken unless the Department is present. Cores shall be tested by an independent CSA certified Category 1 or higher level testing laboratory and in accordance with the requirements of CSA Standard A23.2-14C. The average strength of the cores as reported by the testing service shall constitute a test.

The acceptability of the as-delivered concrete shall be determined using the concrete cylinders, with the modifications set out in the next two sentences. In cases where the concrete strength, as indicated by the cores, is higher than the strength based on the concrete cylinder results, the core results shall be used as the basis for acceptance of the concrete. If the core strengths are lower than the strength from the concrete cylinder tests, the cylinder tests shall govern.

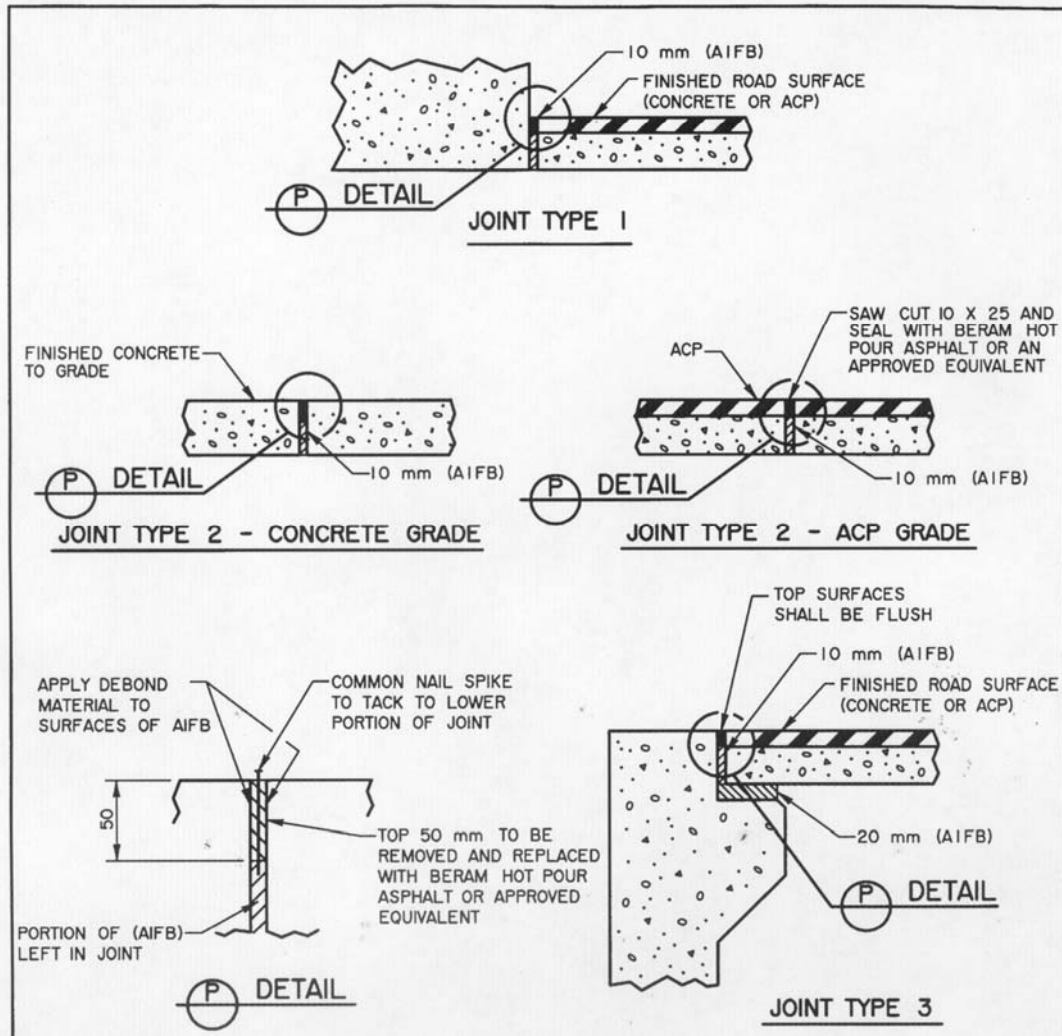

GENERAL NOTES

- DIMENSIONS ARE GIVEN IN mm. DETAILS ARE NOT TO SCALE.
- ASPHALT IMPREGNATED FIBREBOARD (AIFB) SHALL CONFORM TO THE CURRENT ASTM SPECIFICATION D1751 FOR PREFORMED EXPANSION JOINT FILLERS.

5	2003-04-17	REVISED JOINTS TO INCLUDE ACP SURFACE	RY
4	99-04-14	REVISED JOINT 3	RY
3	99-03-29	BEB CHANGED TO TSB	RY
2	94-11-30	PAGE NUMBER	RJR
1	87-03-04	REDRAWN FROM S-1411	DHQ
NO	DATE	REVISIONS	BY

Alberta TRANSPORTATION AND UTILITIES
TECHNICAL STANDARDS BRANCH

**STANDARD
CONCRETE JOINTS**

DESIGNED DHQ	DRAWN MIK	DATE 87-03-04	APPROVED EXECUTIVE DIRECTOR	SIGNATURE <i>[Signature]</i>	DATE 11/9/87	PAGE 4.33	DRAWING S-1411-87
-----------------	--------------	------------------	--------------------------------	---------------------------------	-----------------	--------------	----------------------

PLOTTED APR 17, 2003 51411X87.RVS

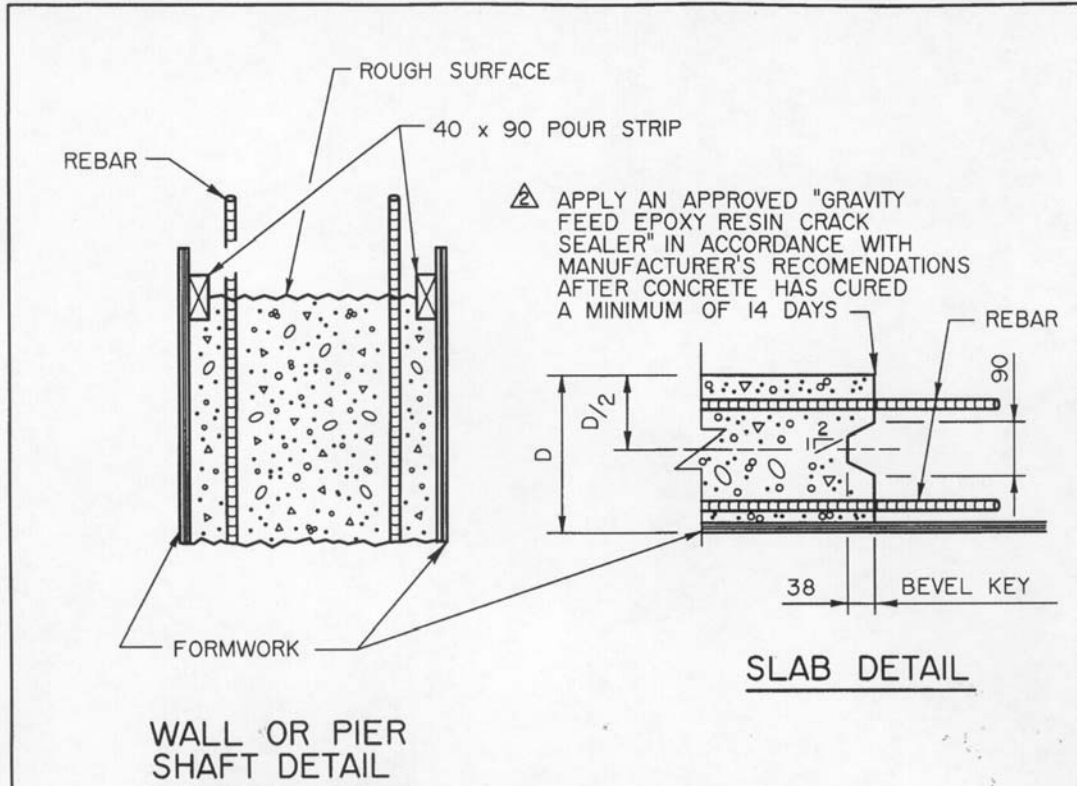

GENERAL NOTES

- DIMENSIONS ARE GIVEN IN mm. DETAILS ARE NOT TO SCALE.
- SURFACES OF HORIZONTAL JOINTS SHALL BE THOROUGHLY CONSOLIDATED AND INTENTIONALLY LEFT IN A ROUGHENED CONDITION.
- JOINTS SHALL BE CLEANED OF SURFACE LAITANCE AND OTHER FOREIGN MATERIALS PRIOR TO PLACING NEW CONCRETE.

⑧

DRAFTING STANDARDS PAGE: 6.3

				Alberta TRANSPORTATION AND UTILITIES TECHNICAL STANDARDS BRANCH	
				STANDARD CONSTRUCTION JOINTS	
DESIGNED	DRAWN	DATE	APPROVED	SIGNATURE	DATE
RY	WS	99-04-12	EXECUTIVE DIRECTOR	<i>[Signature]</i>	11/08/87
NO	DATE	REVISIONS	BY		
④					
③					
②	01-06-06	SLAB DETAIL JOINT REVISED	RY		
①	99-04-12	REDRAWN FROM S-1412-98 REV ①	RY		
PAGE		DRAWING			
4.35		S-1412-99			

PLOTTED JUNE 06, 2001 S1412X99.RW

300.5.8 STRUCTURAL STEEL

300.5.8.1 General

This specification in Section 300.5.8 is for the supply, fabrication, delivery and erection of structural steel. Structural steel shall include steel girders, trusses, diaphragms, bracing, splice plates, deck drains, structural bearings, anchor bolts, dowels, deck joint assemblies, buffer angles, connector angles, anchor bolt sleeves, curb and median cover and trough plates, pier nose plates, pier bracing, bridge rails and miscellaneous components.

300.5.8.2 Submissions

The following information shall be submitted to the Department by a date that is reasonable having regard to the design and construction process and in any event no later than 21 days after request by the Department, acting reasonably:

- Proposed fabrication sequences. The Department shall be advised a minimum of two days prior to a component being ready for inspection at an inspection station;
- Web and flange plate arrangements for welded plate girders;
- Welding procedures for all welds;
- Shop drawings (two copies);
- Mill certificates for all material;
- Repair procedures for excessive girder camber, if required;
- Repair procedures for unsatisfactory weldments and accidental arc strikes, if required;
- Repair procedures for flame straightening of members, if required;
- Product data sheets for coatings required between galvanized steel and concrete;
- Repair procedures for galvanizing, if required;
- Erection procedures, including drawings for falsework, berms and traffic accommodation (two copies); and
- Procedures for straightening bent material during erection, if required.

300.5.8.3 Supply and Fabrication

300.5.8.3.1 Standards

Fabrication of structural steel shall conform to “*The American Association of State Highway and Transport Officials (AASHTO), Standard Specifications for Highway Bridges*” and the *American Welding Society (AWS) - Bridge Welding Code, D1.5*.

All welding, cutting and preparation shall be in accordance with the *AWS - Bridge Welding Code, D1.5*.

300.5.8.3.2 Qualification

The Contractor shall be responsible for the work of all subcontractors.

The fabricator shall operate a recognized steel fabricating shop and be fully approved by the CWB as per Canadian Standards Association (“CSA”) Standard W47.1.

Only welders, welding operators and tackers approved by the CWB in the particular category shall be permitted to perform weldments. Their qualifications shall be current and available for auditing by the Department.

300.5.8.3.3 Engineering Data

(1) Approval of Plate Arrangement for Welded Plate Girders

Prior to the placing of material orders, the Contractor shall prepare sketch drawings showing the general description of the proposed fabrication scheme. This shall include the general arrangement of plates or shapes, including the location of all shop and field splices.

(2) Welding Procedures

Welding procedures shall be prepared for each type of weld used in the structure. The procedures shall bear the approval of the CWB and shall also be submitted to be reviewed by the Department prior to use on the structure.

(3) Shop Drawings

Shop drawings showing all details shall be prepared by the Contractor. The shop drawings shall be legible and of adequate quality to be reproduced and microfilmed.

In addition to specific details, the shop drawings shall include the following:

- (a) Drawings showing details of connections not shown on the design drawings shall bear the signature and stamp of a Professional Engineer;
- (b) All dimensions shall be correct at 20°C unless otherwise noted;
- (c) Weld procedure identification shall be shown on the shop drawings in the tail of the weld symbols;
- (d) All material splice locations shall be shown on the drawings;
- (e) Bearings shall be centered at -5°C;
- (f) Shop assembly drawings shall indicate camber and splice joint offsets measured to the top of top flange; and
- (g) The Department’s bridge file number and project name shall be shown on all the shop drawings.

(4) Proposed Fabrication Sequence

Prior to commencement of fabrication, the Contractor shall prepare an outline of the fabrication sequence that clearly describes the order of make-up and assembly of all the component parts, as well as shop assembly, inspection stations, and surface preparation.

(5) **Mill Certificates**

Mill certificates shall be obtained for all material before fabrication commences.

300.5.8.4 **Materials**

(1) **Structural Steel**

Structural steel shall conform to the standard noted on the Detailed Designs. Interpretation of equivalent steels will be as per Appendix “A” of the CSA Standard G40.21 (1976 only). Mill certificate data and results of impact tests shall be obtained prior to shipment of material from the mill to provide sufficient time for replacement or for heat treating of material that does not meet the Technical Requirements.

The silicon equivalent of structural tubing used for bridgerail tubing shall be less than 0.04%.

(2) **Bolts**

All bolts, nuts and washers shall conform to ASTM Standard A325 or shall meet property class 8.8 of the Industrial Fasteners Institute for metric high strength structural bolts, nuts and washers. Metric bolts shall be marked with the symbol A325M and those of a “weathering” steel shall have the A325M symbol underlined. Metric nuts shall be marked with three circumferential lines with an “M” between two of them or shall be marked with a “3” if made of a weathering grade. Washers shall be identified as metric preferably by having an “M” indented in the surface or a “3” for weathering grades. Certified mill test reports for the fastener material shall be obtained.

(3) **Stud Shear Connectors**

All stud shear connectors shall conform to the chemical requirements of ASTM Standard A108, Grades 1015, 1018 or 1020. In addition they shall meet the mechanical properties specified in AWS D1.5, Table 7.1 for Type B studs. Certified mill test reports for the stud material shall be obtained.

(4) **Bearings**

(a) Stainless Steel

Stainless Steel shall conform to the requirements of American Iron and Steel Institute (“AISI”) Standard Type 304, No. 4 Polished Finish with the grain parallel to the length of the girder.

(b) Neoprene/Natural Rubber

Neoprene/natural rubber shall conform to Grade 5 of Section 18 “Bearing Devices” Division II of AASHTO. Hardness shall conform as specified.

(c) Teflon

Teflon shall be unfilled, 100% virgin polymer.

(d) Base Plate Corrosion Protection

The bottom face of each base plate shall be protected by a medium grey colour barrier coating, to prevent contact between the zinc and the concrete. The galvanized surface must be roughened prior to application of barrier coating. The surface preparation of the galvanized surface and the dry film thickness (DFT) of the coating shall be in accordance with the coating manufacturer's recommendations. The Contractor shall test the adhesion of fully cured coating as per ASTM D3359 A Standard Test Methods for Measuring Adhesion by Tape Test. The method selected for testing (Method A or B) shall depend on the dry film thickness of the coating. The coating manufacturer's product data sheets shall be obtained prior to the application of the coating. The adhesion test result shall meet a minimum of A4B classification i.e. a maximum allowable flaking of 5%.

300.5.8.4.1 Welding

(1) Filler Metals

Low hydrogen filler, fluxes and low hydrogen welding practices shall be used throughout. The low hydrogen covering and flux shall be protected and stored as specified by AWS Standard D1.5. Flux cored welding or use of cored filler wires in the submerged arc process or shielding gas processes, are not considered as conforming to low hydrogen practice, and will not be permitted.

(2) Cleaning Prior to Welding

Weld areas must be clean, free of mill scale, dirt, grease and other contaminants prior to welding.

(3) Submerged Arc Process

All flange and web butt joints and all stiffener to web fillet welds shall be made by an approved semi or fully automatic submerged arc process. All web to flange fillet welds shall be made by an approved fully automatic submerged arc process.

(4) Tack and Temporary Welds

Tack and temporary welds shall not be allowed unless they are to be incorporated in the final weld. Tack welds, where allowed, shall be of a minimum length of four times the nominal size of the weld and length shall not exceed 15 times the weld size, and shall be subject to the same quality requirements as the final welds. Cracked tack welds shall be completely removed prior to welding over.

(5) Run-off Tabs

Run-off tabs shall be used at the ends of all welds that terminate at the edge of a member. They shall be tack welded only to that portion of the material that will not remain a part of the structure, or where the tack will be welded over and fused into the final joint. After welding, the tabs are to be removed by flame cutting, not by breaking off.

(6) Preheat

Preheat requirements shall be performed and maintained as per AWS D1.5, except that all welds on girder flanges shall be preheated to a minimum temperature of 100° C unless a higher temperature is required by AWS D1.5 for the flange thickness. The preheat temperature of the web to

flange joint shall be measured 75 mm from the point of welding on the side of the flange opposite to the side where the weld is being applied.

(7) Welding at Stiffener Ends

To prevent notching effects, stiffeners and attachments fillet welded to structural members shall have the fillet welds terminate 15 mm short of edges.

(8) Methods of Weldment Repair

Repair procedures for unsatisfactory weldments shall be prepared by an experienced welding engineer registered as a Professional Engineer prior to repair work commencing.

(9) Arc Strikes

Arc strikes will not be permitted. In the event of accidental arc strikes a repair procedure shall be prepared by an experienced welding engineer registered as a Professional Engineer. The repair procedure shall include the complete grinding out of the crater produced by the arc strike.

(10) Grinding of Welds

Flange butt welds shall be ground flush or to a specified slope on both sides. Web butt welds which are sufficiently smooth with a neat appearance and uniform profile will not require grinding. Fillet welds not conforming to acceptable profile shall be ground to the proper profile without substantial removal of the base metal. Grinding shall be smooth and parallel to the line of stress. Caution shall be exercised to prevent over grinding.

(11) Plug and Slot Welds

Plug welds or slot welds shall not be permitted.

300.5.8.4.2 Fabrication

Fabrication shall be performed in an enclosed area which is adequately heated.

(1) Heat Number Transfer

As the plate is subdivided for webs and flanges, all heat numbers shall be transferred to each individual section. The numbers shall remain legible until such time as the material location in the final assembly has been recorded. Mill identification numbers stamped into the material shall be removed by grinding at an appropriate time.

(2) Marking Systems

Steel stamps shall not be used. The only exception is the match marking of splice plates which may be steel stamped using low stress stamps. The stamps and specific locations of such stamps must be shown on the drawings.

(3) Cutting of Plate

All plate material for main members, splice plates and any plate material welded to the main member shall be flame cut using an automatic cutting machine. Shearing is not allowed.

(4) Flange Stripping

All flange material shall be cut so that the direction of the applied stress will be parallel to the direction of the plate rolling.

(5) Flame Cut Edges

The flame cut edges of girder flanges shall have a maximum Brinell hardness as stated by Section 300.5.8.4.4(10) (Hardness Test). The surface roughness of the flame cut edge shall not be greater than ANSI B46.1 500 $\mu\text{in.}$ (12.5 μm) and be such that to allow Brinell hardness testing without spot grinding. The Contractor shall report all blow backs or signs of lamination observed during the cutting of the material. The Contractor will perform Brinell hardness tests on the as is flame cut edge. If the hardness exceeds the requirements, the edges shall be repaired so that they meet the requirements.

The surface of flame cut apertures shall be finished by grinding and shall be free of nicks and gouges.

(6) Vertical Alignment

The structure shall be fabricated to conform to the requirements of the deflection and vertical curve, as noted on the drawings. For rolled shapes, advantage shall be taken of mill camber that may be inherent in the material.

(7) Shop Assembly

(a) Plate Girders

Shop assembly of girders shall be by the progressive assembly method according to AASHTO, except that only two, instead of three, sections need to be assembled. The detailed method of assembly, including points of support, dimensional checks, method of trimming to length, drilling and marking of splices, shall be to the procedure prepared as per Section 300.5.8.3.3(4) (Proposed Fabrication Sequence). Each individual girder section shall meet the camber requirements for that particular length, with the splices between these sections falling on the theoretical camber line for the entire span. Correction for variation in flange thickness must be considered. When the camber of the girder fails to meet the required tolerance, the Contractor shall develop a method of repair prior to commencement of repair. The camber of each individual girder section must be known for the next two girder sections in the girder line prior to shop assembly of any particular girder section. This is to allow the use of a best fit line to reduce the effect of any camber differences should it be deemed necessary. Camber for plate girders will be measured on the top of the top flange.

(b) Box Girders

The progressive shop assembly for box girders shall be as per Section 300.5.8.4.2(7)(a) (Plate Girders); items described in this section are specific to box girders.

The camber of box girders shall be measured on the top of the top flange, and each top flange of a box shall individually meet the required camber. Girder sections assembled for splicing shall be supported within 2 m of the end of each section. Girder sections shall be supported in such a manner as to provide the correct angular relationship at the splice between girder sections while the splices are being reamed or drilled. Shop drawings shall clearly indicate the expected dead

load deflection of each section and the elevations of the sections while supported for the drilling or reaming of each splice.

(c) Drilling

All splices shall be drilled from solid material while assembled or shall be sub-punched or sub-drilled and then reamed to full size while in the shop assembly position.

(8) Splice Plates

After shop assembly, splice plates and girders shall be clearly match marked to assure proper orientation and location of splice material for erection. All holes shall align with holes in the attached member. Splice plates shall then be removed, de-burred, solvent cleaned to remove all oil and sandblasted to remove all mill scale in order to provide a suitable faying surface. These plates shall then be securely ship-bolted to the girders. The match marking system shall be shown on the drawings.

(9) Bolt Holes

Clause 11.4.8 in Division II of AASHTO shall apply except that all bolt holes in load carrying segments of main members and any material welded to main members shall be drilled full size or sub-punched and reamed to full size. All holes in girder splices shall be circular and perpendicular to the member and shall be deburred to ensure a proper faying surface.

(10) Dimensional Tolerances

Normal tolerance for structural steel fabrication and fitting between hole groups will be ± 3 mm unless specified otherwise. The dimensional tolerances for structural members shall be within the AWS Standard D1.5, Section 3.5, except as otherwise noted below:

(a) Girder Camber

Camber of beams and girders shall be uniform, true and accurate to the centreline of the top flange. Permissible variation in camber shall be within $\pm (0.2L_t + 3)$ mm; where L_t is the test length in metres. This applies to fabricated pieces only, prior to shop assembly. During shop assembly, splice points shall be located on the theoretical camber line or at a specified amount from the line.

Where field splices are eliminated by combining girder segments into longer girder lengths, the cambers of the girders at the eliminated splice points shall be within ± 3 mm.

(b) Box Girders

Tolerances for box girder camber, sweep and depth shall be measured relative to two imaginary surfaces: a vertical plane passing through the centre line of the girder; and a surface located at the theoretical underside of the top flanges following the theoretical camber of the girder.

(c) Splices

Fill plates shall not be permitted at main girder field splices unless specified. The tolerance for girder depth or box girder geometry shall be as specified by AWS D1.5, except that the difference between similar dimensions of the adjoining sections being spliced shall not exceed ± 3 mm.

(d) Fitted Stiffeners

The bearing ends of bearing stiffeners shall be flush and square with the web and shall have at least 75% of this area in contact with the flanges, whereas fitted stiffeners may have a gap of up to 1 mm between stiffener and flange.

(e) Bearing to Bearing Dimension

Bearing to bearing distance is a set dimension and therefore has no tolerance.

(f) Deck Joint Assemblies

Deck joint assemblies shall be assembled for inspection in a relaxed condition with erection angles removed. Approval of the assembly is required prior to application of the erection angles. Tolerances for straightness shall be considered over the length of the assembly between the crown and gutter line both before and after galvanizing. Deviation from straightness in a vertical plane shall not exceed ± 6 mm. Horizontal sweep or variations in gap setting shall not be greater than 3 mm.

(11) Flange Corner Chamfer

Corners of all flanges shall be ground to a 2 mm chamfer.

(12) Milling Tolerances

Tolerance for milled to bear stiffeners shall be 0.05 mm with at least 75% of the area in bearing.

(13) Web Panning

The maximum variation from flatness for webs shall be $0.01d$ where d is the least dimension of the panel formed by the girder flanges and/or stiffeners. Should the panning in one panel be convex and the panning in the adjacent panel be concave then the sum of the panning in the two adjacent sections shall not exceed that allowed for one panel.

(14) Flame Straightening

Flame straightening shall not be performed on any material or member without the development of a repair procedure by a Professional Engineer. The repair procedure shall address locations, temperatures and cooling rates.

(15) Stress Relieving

When stress relieving is specified, it shall be performed in accordance with AWS D1.5. Copies of the furnace charts shall be supplied to the Department.

(16) Handling and Storage

All lifting and handling shall be done using devices that do not mark, damage, or distort the assemblies or members in any way. Girders shall be stored upright, supported on sufficient skids

and safely shored to maintain the proper section without buckling, twisting or in any way damaging or mis-aligning the material.

300.5.8.4.3 Surface Preparation

(1) Blast Cleaning

Unless otherwise noted, all steel components shall be blast cleaned after fabrication in accordance with the *Society for Protective Coating Standard (SSPC) No. SP6*. Essentially this is a surface from which all oil, grease, dirt, rust, scale and foreign matter have been completely removed, and all rust, mill scale and old paint have been removed except for slight shadows, streaks or discolourations caused by rust stain or mill scale oxide binder.

(2) Galvanizing

Galvanizing shall be by the hot dip method, after fabrication, in accordance with the current edition of CSA Standard G164 with additions and exceptions as described in this specification. The fabricator shall provide a smooth finish on all edges and surfaces, and remove all weld spatter and all welding flux residue from the steel components prior to galvanizing.

The bottom face of each base plate shall be protected by a medium grey colour barrier coating to prevent contact between the zinc and the concrete. The galvanized surface must be roughened prior to application of barrier coating. The surface preparation of the galvanized surface and the dry film thickness (“DFT”) of the coating shall be in accordance with the coating manufacturer’s recommendations. The Contractor shall test the adhesion of fully cured coating as per ASTM D3359. The method selected for testing (Method A or B) shall depend on the dry film thickness of the coating. The coating manufacturer’s product data sheets shall be obtained prior to the application of the coating. The adhesion test result shall meet a minimum of “4B” classification i.e. a maximum allowable flaking of 5%.

Repair of galvanizing shall only be done if bare areas are infrequent, small, and suitable for repair. A detailed repair procedure shall be prepared by a Professional Engineer prior to its use. It should be noted that repairs may require complete removal of the galvanized coating and regalvanizing. Repair shall be in compliance with ASTM A780, Method A3 Metallizing. The thickness of the metallizing shall be 180 µm, and the repair tested for adhesion. The finished appearance shall be similar to the adjacent galvanizing.

300.5.8.4.4 Testing and Inspection

(1) Access

The Contractor shall provide full access for the inspection of material and workmanship by the Department. Free access shall be allowed to the Department to all parts of the works. When required by the Department, the Contractor shall provide needed manpower for assistance in inspection duties.

(2) Testing by the Department

The Department may perform visual, radiographic, ultrasonic, magnetic particle and any other inspection that may be required at its own expense.

(3) Testing by the Contractor

Any test records made by the fabricating shop in the course of normal quality control shall be open to the Department for inspection.

(4) Inspection Station

To ensure that each stage of inspection is performed in an orderly manner, during the fabrication of major structures, inspection stations shall be set up at specific points. Certain items of the work will then be checked, and deficiencies shall be corrected, prior to the work being sent to the next stage of fabrication. These check points are to be identified prior to commencement of fabrication.

(5) Non-destructive Methods of Examination

The methods of non-destructive examination shall be in accordance with the following standards:

- Radiography - AWS Standard D1.5
- Ultrasonic - AWS Standard D1.5
- Magnetic Particle - ASTM Standard E-709
- Dye-Penetrant - ASTM Standard E-165
- Hardness tests - ASTM Standard E-103

(6) Radiographic Inspection Schedule

Unless otherwise noted, radiographic inspection of welded plate girders shall be performed in accordance with the following schedule:

- (a) 100% of all tension flange butt welds, all stiffener butt welds and all diaphragm butt welds, and any groove welded attachments to flange plates.
- (b) 25% of all other flange butt welds.
- (c) All web butt welds in tension zone plus additional 300 mm of web butt weld in compression zone at the end of the web.

(7) Radiographic Inspection of Miscellaneous Material

Unless otherwise noted, radiographic inspection of miscellaneous material shall be performed in accordance with the following schedule:

- (a) 100% of all tension members.
- (b) 50% of all other members.

(8) Magnetic Particle Inspection Schedule

Unless otherwise noted, magnetic particle inspection of welded plate girders shall be performed in accordance with the following schedule:

- (a) 50% of the web to flange welds or any fillet welds placed on flange plates.
- (b) 10% of the web to stiffener welds.
- (c) 100% of the stiffeners to flange welds.
- (d) 100% of the bearing sole plate to flange welds.

(e) 20% of the diaphragm connector plate welds.

(9) Dye Penetrant Inspection

Dye penetrant inspection shall be performed at the ends of the weld metal of all flange butt welds after the removal of run-off tabs. Defects discovered by this inspection shall be repaired by the Contractor, and the suspect area re-inspected.

(10) Hardness Tests

Hardness tests shall be performed by the Contractor on the flame cut edges of the girder flange prior to assembly. Unless otherwise noted, the hardness of the flame cut edges shall not exceed a maximum Brinell as noted below:

- (a) For carbon steels with a yield strength less than and including 300 MPa, the maximum Brinell shall be 200 BHN.
- (b) For carbon steels with a yield strength greater than 300 MPa, the maximum Brinell shall be 220 BHN.

Remedial work to the edges which exceed the specified hardness shall be performed and re-inspected prior to assembly.

(11) Testing Stud Shear Connectors

Stud shear connectors shall meet all requirements as outlined by AWS D1.5. When bend testing, the studs shall be bent towards the centre of the girder.

(12) Testing of Deck Joint Strip Seal

The installation of strip seals in deck joints shall be tested by the Contractor for leakage. The failed areas shall be corrected and retested. The defective or torn seal shall be replaced at the Contractor's expense.

300.5.8.5 Structural Steel Erection

The Contractor shall erect the structural steel, remove any temporary construction, and do all work required to complete the erection in accordance with the Detailed Designs and the Technical Requirements. No field welding, drilling or any other field modifications shall be made to steel elements other than deck joints. The Contractor shall not erect the structural steel until the substructure concrete has been cured a minimum of three days and achieved 80% of the 28 day specified concrete strength requirement. Without restricting generality, erection includes:

- placing of anchor bolts and bearings;
- erection of temporary supporting structures;
- erection of structural steel;
- placing of expansion assemblies;
- grouting of anchor bolts;
- placing and sealing of grout pads; and

- touch-up painting as required.

300.5.8.5.1 Handling and Storing Materials

Material to be stored shall be placed on timber blocking. It shall be kept clean and stored in a properly drained area. Girders and beams shall be placed upright and shored. Long members, such as deck joint assemblies, buffer angles, columns and chords, shall be supported on timber blocking to prevent damage from deflection.

300.5.8.5.2 Bridge Girders

(1) Temporary Supporting Structures and Berms

The temporary supporting structures and berms shall be designed, constructed and maintained to safely support all loads. Berms shall be constructed in a manner and of such materials that they will not be eroded by stream flow nor introduce silt into the water. The Contractor shall prepare drawings for temporary supporting structures, berms, and for traffic control and accommodation where applicable. All drawings shall bear the seal of a Professional Engineer.

Temporary supporting structures and/or berms will not be permitted to remain in any stream channel during spring break-up or run-off periods, unless all necessary approvals have been obtained from pertinent agencies.

Incidental damage to other property, such as earth fills and stream banks, resulting from the existence of berms, shall be the responsibility of the Contractor.

(2) Erection Procedure

The Contractor shall prepare a detailed erection procedure in advance of the scheduled start of erection. The erection procedure shall include all drawings and documents necessary to describe the following:

- (a) Traffic accommodation strategy, as applicable.
- (b) Access to work, earth berms and work bridges.
- (c) Type and capacity of equipment.
- (d) Sequence of operation including position of cranes and trucks with members.
- (e) Position of cranes relative to substructure elements such as abutment backwalls, with details of load distribution of wheels and outriggers.
- (f) Lifting devices and lifting points.
- (g) Details of temporary works, supporting structures drawings, including proposed methods to be used to ensure the required splice elevations and structure shape prior to bolt torquing.

Method of providing temporary supports for stability. Top of girder elevations at each bearing and each slice location where appropriate.

- (h) Bolt tightening sequence.
- (i) Grout Pad Construction (refer to Section 300.5.8.5.2 (10) (Grout Pockets and Grout Pads)).
- (j) Details of release of temporary supporting structures.
- (k) Provide an “As-Constructed” detailed survey of the substructure showing the following:
 - location and elevation of all bearing grout pad recesses,
 - shim height at each bearing location,
 - top of girder elevations at each bearing (and each splice location where appropriate),
 - longitudinal measurements between centrelines of bearings of all substructure units.

The erection procedure shall be stamped by a Professional Engineer, who shall assume full responsibility to ensure that its erection procedure is being followed. Safety and compliance with the *Occupational Health and Safety Act* (Alberta) and regulations thereunder, shall be an integral part of the design.

Before erection begins the Contractor shall do a complete superstructure layout by means of chalk lines and markings applied to all substructure units, showing bearing and girder positions in accordance with the layout plan.

(3) **Fall Protection for Girder Erection and Deck Forming**

In order to provide a safe working area for girder erection and deck formwork, the Contractor shall provide 100% fall protection and a safe work procedure.

(4) **Bearings and Anchorage**

Masonry bearing plates shall not be placed upon bridge seat bearing areas which are improperly finished, deformed or irregular. Bearing plates shall be set level in their exact position.

The Contractor shall remove anchor bolt void forming materials, and accurately set the anchor bolts, except where the bolts were cast into the concrete. Any residues on the concrete surfaces, such as oils, grease or other contaminants, shall be removed by sandblasting. All methods and materials for setting anchor bolts and constructing bearing pads shall be subject to the Department’s prior review and acceptance. The location of the anchor bolts, in relation to the slotted holes in the expansion shoes, shall correspond with the temperature at the time of erection. The nuts on the anchor bolts, at the expansion ends of spans, shall be adjusted to permit free movement of the spans.

When steel bearings are employed in conjunction with grout pockets in the substructure, the bearings shall be set accurately on galvanized steel shims, and grouted as detailed on the drawings, after the erection has been completed. The shims must be located so that a minimum 75 mm grout coverage is provided. When grout pockets are not detailed, the bearing plates shall

be set on the properly finished bearing areas in exact position and shall have a full and even bearing on the concrete.

(5) Straightening Bent Material

Straightening of plates, angles or other shapes will not be permitted without a detailed procedure prepared by a Professional Engineer prior to any straightening being undertaken.

Following the straightening of a bend or buckle, the surface of the metal shall be carefully inspected for evidence of fractures, which may include non-destructive testing.

(6) Assembly

The parts shall be accurately assembled as shown on the drawings and all match-marks shall be followed. The material shall be carefully handled to avoid damage. Hammering, which will injure or distort the members, shall not be permitted. Bearing surfaces and surfaces to be in permanent contact shall be clean before the members are assembled.

Splices and field connections shall have one half of the holes filled with bolts and cylindrical erection pins (half bolts and half pins evenly distributed throughout the splice or connection) before bolting. Splices and connections carrying traffic during erection shall have three-fourths of the holes filled.

Fitting-up bolts shall be of the same nominal diameter as the bolts, and cylindrical erection pins shall be sized to accurately fit the holes.

Should adjustments in elevation of the girder splices become necessary, only enough pins or bolts shall be removed to allow free rotation of the joints.

(7) High-Tensile-Strength Bolted Connections

(a) General

Bolted parts shall fit solidly together when assembled. Contact surfaces, including those adjacent to the washers, shall be descaled or carry the normal tight mill scale. Contact surfaces shall be free of dirt, paint, oil, loose scale, burrs, pits and other defects that would prevent solid seating of the parts. Bolts in exterior girders shall be installed with the heads on the outside face of the girder web unless otherwise noted.

Connections shall be assembled with a hardened washer under the bolt head or nut, whichever is the element turned in tightening. Surfaces of bolted parts in contact with the bolt head and nut shall be parallel.

For sloped surfaces, bevelled washers shall be used. The bevelled washers shall be designed to produce a bearing surface normal to the bolt axis.

Bolts shall be of new quality and stored in weatherproof containers to prevent loss of lubrication or accumulation of dirt.

All girders shall be erected with elevations and alignments checked prior to any bolt tightening.

(b) Bolt Tension

Tightening of all high strength bolts shall be by the turn-of-nut method. Before final tightening there shall be a sufficient number of bolts brought to a “snug tight” condition to ensure that the parts of the joint are brought into full contact with each other. “Snug tight” is defined as the tightness attained by a few impacts of an impact wrench or the full effort of a man using an ordinary spud wrench. Following this initial operation, bolts shall be placed in any remaining holes in the connection and brought to snug tightness. After all bolts have been taken to the snug tight condition, the Contractor shall match mark the outer face of each nut and protruding end of bolt to have a common reference line to determine the relative rotation. All bolts in the joint shall then be tightened additionally by the applicable amount of nut rotation specified below, with tightening progressing systematically from the most rigid part of the joint to its free edges. During this operation there shall be no rotation of the part not turned by the wrench.

Amount of rotation of nut relative to bolt, regardless of which is turned:

- 1/3 turn where bolt length is 4 bolt diameters or less
- 1/2 turn where bolt length is over 4 bolt diameters and not exceeding 8 bolt diameters
- 2/3 turn where bolt length exceeds 8 bolt diameters

Notes:

- tolerance 1/6 turn (60°) over, nothing under
- length of bolt measured from underside of head

(c) Department Inspection

The Contractor shall provide safe and adequate access meeting *Occupational Health and Safety Act* (Alberta) requirements to all working areas, including all necessary scaffolding to enable the Department to carry out its inspection. The Contractor shall provide a competent workman to assist the Department in the inspection of bolt tightening work.

(8) Misfits

The correction of minor misfits involving reasonable amounts of reaming, cold cutting and chipping will be considered incidental to the work of erection. However, any deformation which prevents the proper assembling and fitting up of parts by the moderate use of drift pins, or by a moderate amount of reaming and slight chipping or cutting, shall be reported immediately to the Contractor’s Engineer.

(9) Girder Adjustment

It is essential that the girders are erected with utmost attention being given to girder positioning, alignment, and elevation. Adjustment to girder position, bearing location and bearing elevation shall be done in order to achieve as closely as possible the lines and grades shown on the drawings.

The Contractor shall ensure that the structural steel is maintained in correct alignment until the adjoining or encasing concrete components have been completed.

(10) Grout Pockets and Grout Pads

The Contractor shall fill the grout pockets and construct the grout pads using Sika 212 flowable grout or equivalent. Filling of grout pockets and construction of grout pads shall be done by workers competent in this work.

Grout shall be packaged in waterproof containers with the production date and shelf life of the material shown. It shall be mixed, placed, and cured in strict accordance with the manufacturer's recommendations.

Sealer shall be supplied and applied to the exposed grout pad surfaces in accordance with Section 300.5.7 (Cast-In-Place Concrete).

(11) Grouting in Cold Weather

When the daily minimum air temperature, or the temperature of the girders, bearings or substructure concrete, in the immediate area of the grouting, falls below 5°C, the following provisions for cold weather grouting shall be effected:

- (a) Before grouting, adequate preheat shall be provided to raise the temperature of the adjacent areas of the girders, bearings and substructure concrete to at least 10°C.
- (b) Temperature of the grout during placing shall be between 10°C and 25°C .
- (c) The grout pads (or girders where appropriate) shall be enclosed and kept at 10°C to 25°C for at least five days. The system of heating shall be designed to prevent excessive drying-out of the grout.

(12) Removal of Falsework, Berms, and Clean-Up

Upon completion of the erection the Contractor shall remove all earth material or falsework placed in the stream channel or elsewhere during construction. The Contractor shall remove all piling, excavated or surplus materials, rubbish and temporary buildings, replace or renew any damaged fences, and restore in an acceptable manner all property damaged during the execution of its work.

The Contractor shall leave the bridge site, roadway and adjacent property in a neat restored, and presentable condition. When required, the Contractor shall provide written evidence that affected property owners or regulatory agencies have been satisfied.

All steel shall be left clean and free of oil, grease, mud, dust, road spray or other foreign matter.

300.5.9 PRECAST CONCRETE UNITS

300.5.9.1 General

This specification in Section 300.5.9 is for the supply, manufacture, delivery and erection of prestressed and precast concrete bridge units and miscellaneous precast components.

300.5.9.2 Submissions

The following information shall be submitted to the Department by a date that is reasonable having regard to the design and construction process and in any event no later than 21 days after request by the Department, acting reasonably:

- Shop drawings (two copies);
- Stressing calculations including jack calibration data (two copies);
- Load/elongation curve for prestressing strand;
- Concrete and grout mix designs, including test data showing conformance of cement, silica fume, aggregate and admixtures to required standards;
- Mill certificates for miscellaneous steel;
- Repair procedures for galvanizing, if required;
- Repair procedures, if required, for repair of casting defects or other damage to precast concrete units;
- Concrete cylinder strength results;
- Concrete core strength results, if required; and
- Erection procedures, including drawings for falsework, berms and traffic accommodation (two copies).

300.5.9.3 Reference Drawing (attached after Section 300.5.9.10.13)

Type 1c Sealer for Precast Girders S-1637-97

300.5.9.4 Supply and Manufacture

300.5.9.4.1 Standards

The manufacture of prestressed and precast concrete bridge units shall be in accordance CSA A23.4.

Where imperial/metric conversions are necessary, The National Standard of Canada, CAN3-Z234.1-79 shall be used as the basis of conversion.

300.5.9.4.2 Qualification

The manufacturer shall operate a plant that is certified by the Canadian Standards Association in the appropriate category(ies) according to CSA A251, *Qualification Code for Manufacturers of Architectural and Structural Concrete*.

300.5.9.5 Engineering Data

(1) Shop Drawings

Shop drawings showing all necessary fabrication details of the precast units, such as reinforcing steel, blockouts, stressing system, anchorage devices, void support system and screed rail shall be prepared. The shop drawings shall be legible and of adequate quality to be reproduced and microfilmed.

The Department's bridge file number and project name shall be shown on shop drawings.

(2) Stressing Calculations

Stressing calculations showing elongations and gauge pressures as well as the strand release sequence data shall be prepared. Jack calibrations, performed within the previous six months, shall be obtained.

(3) Stressing Steel Certificate

A copy of the load/elongation curve for each lot of stressing steel shall be obtained.

(4) Concrete and Grout Mix Design

A concrete mix design and grouting mortar mix design shall be prepared by the Contractor. The mix design shall indicate the design strength, proportions of the constituent materials, type and brand of cement, type and brand of silica fume, origin of aggregates and brand names of all admixtures.

The concrete mix design information shall include one microscopic air-void analysis performed by an independent testing laboratory in order to determine the spacing factor of the hardened concrete. The test sample shall be made from a trial concrete batch, vibrated into a cylinder mould so as to represent the level of vibration of the production concrete in the forms. If adjustments to the mix design are necessary, the air-void analysis shall be repeated.

Only the prepared mix design shall be used to cast units. Changes in cement type, and/or decreasing cement content shall be construed as a change in mix design and will not be allowed.

(5) Other Data

Test data to prove conformance to the standards for other materials including cement, silica fume, aggregate and admixtures shall be obtained.

(6) **Construction Data Sheets**

During manufacture, the construction data sheets shall be kept up to date and available for the Department's review.

300.5.9.6 **Materials**

(1) **Cement**

Portland cement conforming to the requirements of CSA A5 shall be used.

(2) **Water**

Water to be used for mixing concrete or mortar shall conform to the requirements of CSA Standard A23.1 and shall be free from injurious amount of alkali, organic materials or deleterious substances. The Contractor shall not use water from shallow, stagnant or marshy sources.

(3) **Silica Fume**

Ten percent condensed silica fume by weight of cement (plus or minus 0.5%) shall be used in all precast concrete. Condensed silica fume shall conform to Tables 5 and 6 of CSA Standard A3000-03 - Cementitious Material Compendium, Type SF, with a SiO₂ content of at least 85%, of a maximum of 10% ignition loss, and no more than 1% SO₃ content. An acceptable compatible superplasticizing admixture shall be used together with the silica fume.

(4) **Aggregates**

(a) Normal Weight Aggregates

Fine and coarse normal weight aggregates shall conform to the requirements of CSA A23.1, with maximum aggregate size of 14 mm.

(b) Lightweight Aggregates

Fine and coarse lightweight aggregates shall conform to the requirements of the ASTM C330, with maximum aggregate size of 14 mm.

(5) **Air Entraining Agent**

Air entraining agent shall conform to the requirements of the ASTM C260.

(6) **Chemical Admixtures**

Chemical admixtures shall conform to the requirements of ASTM C494. All chemical admixtures must be suitable for use in precast concrete, be supplied by the same manufacturer as the air entrainment agent, and be compatible with each other.

(7) **Concrete**

Concrete shall consist of Portland cement, condensed silica fume, aggregates, water and acceptable admixtures. The type of concrete to be used will be specified on the Detailed Designs.

The unit weight, entrained air and air void spacing requirements for the various types of concrete are specified in Table 300.5.9.6 below.

Table 300.5.9.6

TYPE OF CONCRETE	Aggregates	Concrete Unit Weight, Plastic State kg/m ³	Minimum Total Air Content %	Maximum Air Void Spacing Factor (hardened concrete) mm
Standard Weight	Fine and Coarse Standard Weight	--	5	0.23
Lightweight	Fine and Coarse Lightweight	1680 ± 5%	6	0.23
Semi-Lightweight	Fine Standard Weight & Coarse Lightweight	1920 ± 5%	6	0.23

(8) Reinforcing Steel

Plain and epoxy coated reinforcing steel shall conform to Section 300.5.14 (Reinforcing Steel).

(9) Prestressing Strand

Prestressing strand and wire shall conform to the requirements of the ASTM A416 or A421, as specified. Shop drawings and stressing calculations shall clearly show the type of strand to be used, and changes will not be allowed during production.

(10) Lifting Hooks

Lifting hooks made of prestressing strand shall conform to the requirements of ASTM A416, and shall be fabricated in a manner that distributes the load evenly to all strands.

(11) Miscellaneous Steel

Miscellaneous steel shall conform to the requirements of the CSA *CAN/CSA G40.21M-300W* or *ASTM A36* or as specified on the drawings. The Contractor shall obtain mill certificates to prove conformance to the standard. Fabrication shall conform to Section 300.5.8 (Structural Steel).

(12) Bridgerail and Anchor Bolts

The assemblies shall be hot dip galvanized after fabrication. All nuts and washers shall be shop assembled on the anchor bolts.

(13) Voids and Ducts

All void and duct material must remain dimensionally stable during the casting and steaming of the units. Voids shorter than 400 mm shall be eliminated except when noted otherwise on the drawings.

(14) Bearings

(a) Stainless Steel

Stainless Steel shall conform to the requirements of AISI Type 304, No. 4 Polished Finish with the grain parallel to the length of the girder.

(b) Elastomer

Elastomer shall conform to Section 18 “Bearing Devices” Division II of AASHTO. Hardness shall conform as specified.

(c) Teflon

Teflon shall be unfilled, 100% virgin polymer.

(15) Base Plate Corrosion Protection

The bottom face of each base plate shall be protected by a medium grey colour barrier coating, to prevent contact between the zinc and the concrete. The galvanized surface must be roughened prior to application of barrier coating. The surface preparation of the galvanized surface and the dry film thickness (DFT) of the coating shall be in accordance with the coating manufacturer=s recommendations. The Contractor shall test the adhesion of fully cured coating as per ASTM D3359 AStandard Test Methods for Measuring Adhesion by Tape Test@. The method selected for testing (Method A or B) shall depend on the dry film thickness of the coating. The coating manufacturer=s product data sheets shall be obtained prior to the application of the coating. The adhesion test result shall meet a minimum of A4B@ classification i.e. a maximum allowable flaking of 5%.

(16) Galvanizing

Galvanizing shall be by the hot dip method, after fabrication, in accordance with the current edition of CSA Standard G164 with additions and exceptions as described in this specification. The Contractor shall provide a smooth finish on all edges and surfaces, and remove all weld spatter and all welding flux residue from the steel components prior to galvanizing.

Repair of galvanizing shall only be done if bare areas are infrequent, small and suitable for repair. A detailed repair procedure shall be prepared by a Professional Engineer prior to its use. It should be noted that repairs may require complete removal of the galvanized coating and regalvanizing. Repair shall be in compliance with ASTM A780, Method A3 Metallizing. The thickness of the metallizing shall be 180 µm, and the repair tested for adhesion. The finished appearance shall be similar to the adjacent galvanizing.

300.5.9.7 Manufacture

(1) Girder Forms

The girders are to be manufactured in steel forms.

(2) **Reinforcing Steel**

Fabrication, handling, storage, placement and fastening of all steel reinforcement shall conform to Section 300.5.14 (Reinforcing Steel).

(3) **Stressing Strand**

Stressing strand shall be free from corrosion, dirt, grease, rust, oil or other foreign material that may impede bond between the steel and the concrete. Stressing strand shall be protected at all times from manufacture to encasing concrete or grouting. Stressing strand that has sustained physical damage at any time shall be rejected.

The girder ends shall have 15 mm deep strand termination recesses formed around the strands. All strands shall be cut flush with the bottom of the recesses, and the recesses shall then be cement mortar grouted flush with the ends of the girders. An approved Type 1C sealer shall be applied over the patched recessed areas prior to steam curing, except when girder ends are designed to be encased in field cast concrete.

The Contractor shall be responsible for recording and reporting the elongation, or tension of each strand during the stressing operation.

(4) **Void and Duct Placement**

Voids and ducts shall be placed as shown on the drawings and must be tied and securely held in the required positions to prevent movement. Continuous ducts shall align precisely. The ends of the voids shall be sealed. Voids found to be distorted, damaged or of insufficient strength will be rejected. Blow holes caused by air expanding within the voids and rising to the surface, shall be repaired when the concrete is in the plastic state.

(5) **Concrete Measuring, Mixing and Placing**

The procedures outlined in ACI 304 shall be followed. The time from initial mixing of the concrete until placing the concrete in the forms shall not exceed one hour.

(6) **Concrete Temperature**

The concrete temperature shall be not less than 10 °C nor greater than 30 °C at the time of placing in the forms.

(7) **Finished Riding Surface**

Where the top surface of the girder is designed to be the riding surface, the use of a continuous screed rail, independent of the top of the grout keys, shall be employed. The top surface shall follow a smooth profile, which incorporates the required camber adjustments.

(8) **Camber Hubs**

Three camber hubs shall be placed in each girder, located along the centreline of the girder at the midpoint and 150 mm from each end. The camber hubs shall consist of 10 mm galvanized bars, of sufficient length to project vertically 10 mm above the riding surface.

The Contractor shall store the members in such a manner as to provide access for measuring camber.

(9) Concrete Finish

The concrete surfaces of units shall be finished as specified.

(a) Class 1 Form Surface Finish

This finish is essentially that obtained when concrete has been cast and adequately compacted in a properly oiled steel form. All fins, honeycomb, irregularities, cavities over 10 mm diameter or other similar defects shall be thoroughly chipped out. These areas shall be saturated with water for a period of not less than 30 minutes, carefully pointed and trued with mortar of a colour which will match the existing concrete. Mortar used for pointing shall be less than one hour old. The patches shall be properly cured by placing the repaired unit in the steam cure for a period of four days immediately after patching.

The finished surfaces shall be true and uniform. All surfaces which cannot be repaired satisfactorily shall be finished as specified for Class 2.

(b) Class 2 Rubbed Finish

Class 2 finish shall be essentially the same as Class 1 except that all holes, cavities and defects shall be repaired so that the finished surface presents a smooth, true, dense, uniformly coloured, and non-stained appearance. The concrete surfaces shall be thoroughly wire brushed to expose any hole or cavity prior to repairs. All residue of form oil shall be removed from the surface.

(c) Class 3 Bonded Concrete Surface Finish

The surface shall be prepared in accordance with the requirements of Class 2 except that it need not be of uniform colour. When surface preparation has been completed the Contractor shall then apply a pigmented concrete sealer such as Capseal A50 or equivalent, which meets the requirements for a Type 3 sealer of the Alberta Transportation's "*Concrete Test Procedure - B388*".

The pigmented sealer shall be applied in accordance with the manufacturer's specifications. At least two applications of the coating are required, and the Contractor shall ensure that no colour variation will be visible. The Contractor assumes full responsibility for the acceptable performance and appearance of the pigmented sealer.

(d) Class 4 Floated Surface Finish

After the concrete has been consolidated and the surface carefully screeded to the cross section and profile shown on the drawings, it shall be floated and trowelled as necessary to provide a closed, uniformly textured surface without brooming.

(e) Class 5 Floated Surface Finish, Broomed Texture

After the concrete has been consolidated, the surface shall be carefully screeded to the cross section and profile shown on the drawings. When the concrete has hardened sufficiently, the surface shall be finished with a broom of an accepted type. The broom strokes shall be perpendicular to the edge of the unit, and extended from edge to edge, with adjacent strokes

slightly overlapped producing corrugations of 2 to 3 mm in depth. Brooming shall be done when the concrete has set sufficiently to produce clear, crisp brooming marks which do not sag or slump, without tearing the surface or disturbing coarse aggregate particles. After final brooming the surface finish shall be free of porous spots, irregularities, depressions, pockets and rough spots and must not vary more than 5 mm when measured using a 3 m straight edge.

Accepted finishing and edging tools shall be used on all edges and expansion joints after brooming.

(10) Curing

All concrete units shall be cured at an elevated temperature. The curing of concrete units shall essentially be in accordance with ACI 517 unless otherwise specified. The ambient curing temperature shall be increased at a rate not exceeding 20°C per hour until a maximum ambient temperature of not less than 50°C nor more than 60°C is attained. During cooling, the units shall not be subjected to a rapid temperature decrease.

(a) Curing in the Form

The initial application of heat shall commence only after the last of the freshly placed concrete has attained its initial set, normally two to four hours after casting, or longer if normal cement or retarder type admixtures have been used. Heat shall not be applied directly to the concrete, but by a method that will produce a consistent ambient temperature throughout the entire form and enclosure. The increase in temperature and the holding temperature shall be monitored and permanently recorded on a chart at a minimum of 3 quarter points along the form.

(b) Steam Curing After Removal From the Form

Upon removal from the forms the units shall be cleaned, patched and finished within a period not exceeding 12 hours. The units shall be placed in a manner that will facilitate any clean up or repair work, and that will allow full inspection of all surfaces. Within 24 hours of removal from the form, the units shall be placed within a suitable enclosure, maintaining an atmosphere of 100% relative humidity and a uniform ambient temperature of 50°C - 60°C for a period of four days. The concrete units shall not be exposed to temperatures below freezing until the steam curing process has been fully completed.

(11) Release of Stressing Strand

The stressing strand shall not be released until the specified concrete release strength is attained, and the release shall be in accordance with the accepted sequence.

Evidence of casting defects shall be repaired prior to release of the strands.

(12) Repairing Damaged Concrete

Serious damage, honeycomb and other casting defects shall be repaired using repair procedures developed by a Professional Engineer prior to the commencement of the repair. All repairs shall be completed prior to curing of the unit.

(13) Sealer

The Contractor shall supply and install an approved Type 1c sealer to the girder surfaces as shown on Standard Drawing S-1637 “Type 1c Sealer for Precast Girders”. Type 1c sealers shall be in accordance with Section 300.5.7.17 (Sealer). The sealer shall be applied on clean dry surfaces free of form oil, and in accordance with the manufacturer's recommendations.

Sealer shall be uniformly applied at the manufacturer’s specified coverage rate.

It shall be applied in two coats on vertical surfaces while one coat should be adequate on horizontal surfaces in order to obtain uniform coverage.

The Contractor shall ensure that the sealer is not applied in the grout pockets, lifting hook pockets or areas of the girders that will have field concrete cast against them.

The Department reserves the right to sample and test the sealer supplied by the Contractor.

(14) Sandblasting

The concrete surfaces in shear key, block out, diaphragm and girder end void locations shall be sandblast roughened. The blasting shall be sufficient to remove all laitance and uniformly expose the aggregate particles.

(15) Dimensional Tolerances of Cast Units

The maximum dimensional deviation in mm, of cast units from that as detailed on the Detailed Designs shall not exceed the following:

Length	-	$\pm 20 \text{ mm} \times \text{length (m)} \div 50$
Width	-	$\pm 3 \text{ mm}$
Depth	-	$\pm 5 \text{ mm}$
Camber	-	$\pm 20 \text{ mm} \times \text{length (m)} \div 50$
Sweep (NU Girders)	-	1 mm/m
Sweep (Other Girders)-	-	deviation from true, $20 \text{ mm} \times \text{length (m)} \div 50$
Projection of Stirrups		
Top of Girder	-	$\pm 12 \text{ mm}$
Bearing Areas	-	out of flatness of bearing areas, 3 mm
Bulkheads	-	warpage or tilt of ends, 5 mm
Rail Anchor Bolts	-	out of line, 5 mm
	-	in spacing, 5 mm
	-	in projection, 5 mm
Dowel Holes	-	out of plumb, 5 mm
Void Location	-	surface to void dimension, $\pm 15 \text{ mm}$ after casting

(16) Handling and Storage

Precast units shall be handled by means of accepted lifting devices at designated locations. Units shall be maintained in an upright position, supported near the ends and on stable foundations.

300.5.9.8 Testing and Inspection

(1) Access

The Contractor shall provide the Department with suitable and safe access to the works for the purposes of testing and inspection of the precast concrete units. The Contractor shall provide the following:

- (a) Cylinder storage box with temperature control and a max./min. thermometer, as per CSA A23.2-3C.
- (b) A calibrated weigh scale.

(2) Inspection

The Contractor shall be responsible for all quality control and relevant testing. Inspection of the units by the Department will not relieve the Contractor of its responsibility for quality control.

(3) Test Methods

Sampling, making, curing and testing concrete specimens shall be in accordance with the requirements of the following CSA standards:

- Sampling - A23.2-1C
- Concrete Test Cylinders - A23.2-3C
- Testing Concrete Cylinders - A23.2 - 9C
- Air Content - A23.2-4C
- Unit Weight of Concrete - A23.2-6C
- Air Void Determination – A23.2-17C

(4) Testing by the Contractor

The Contractor shall engage a CSA certified testing laboratory to conduct all the required concrete testing and ensure that the concrete supply meets all requirements of the Technical Requirements. The Contractor shall maintain the required air entrainment by testing and making adjustments to the mix prior to and during the placing of concrete in the forms.

The Contractor's testing agency shall make and test concrete cylinders to determine the 28-day compressive strength. Samples for testing shall be taken from the fresh concrete being placed in the forms at the rate of one set of cylinders for every three bridge units cast continuously. A set shall consist of a minimum of three cylinders. A strength test will be the average of the 28-day strengths of the three cylinders (one set). Continuous casting shall mean no break in the casting longer than one hour.

(5) Release Strength Test Cylinders

The Contractor shall arrange to make and test concrete cylinders to prove that the required release strength as stated on the drawing has been attained prior to release of the stressing strand. When one or more units are cast continuously, at least two cylinders shall be taken from the concrete of the last unit poured to represent the release strength for all units. These cylinders shall be cured with the bridge unit. Only testing of the first cylinder will be necessary if the

required release strength is obtained. In the event all cylinders are tested without the required strength being obtained, the Contractor's Engineer shall be contacted.

300.5.9.9 Failure To Meet Strength Requirements

(1) Right of Rejection

The Department reserves the right to reject any concrete whatsoever which does not meet the specified strength determined in accordance with this Section 300.5.9.

In the event that the concrete tested is more than 4 MPa below the specified 28-day compressive strength, the bridge units fabricated from the concrete represented by the test specimens shall be rejected. In the event that the unit has been delivered and/or erected in the field, it shall be removed and returned to the Contractor's plant for replacement.

(2) Coring

If any concrete tested fails to meet the specified strength, the Contractor may request permission to core. If the coring is accepted by the Department, the Contractor shall make arrangements, to employ a CSA certified, Category 1 or higher level qualified testing laboratory, at the Contractor's expense.

The Contractor's Engineer will specify the location of the coring to ensure that the cores represent the same concrete as the cylinders. The average of three adjacent cores taken from one bridge unit shall constitute a test. The cores shall be taken and tested in accordance with CSA Standard A23.2-14C within seven days of the date of testing the 28-day cylinders. The core test will represent all bridge units represented by the strength test. Alternatively, the Contractor may choose to take a core test from each of the other units in question, in which case each of these core tests will then represent a bridge unit.

The acceptability of the as-delivered concrete shall be determined using the concrete cylinders, with the modification set out in the next two sentences. In cases where the concrete strength, as indicated by the cores, is higher than the strength based on the concrete cylinder results, the core results shall be used as the basis for acceptance of the concrete. If the core strengths are lower than the strength from the concrete cylinder tests, the cylinder tests shall govern.

300.5.9.10 Erection of Precast Concrete Girders

300.5.9.10.1 General

The Contractor shall erect the girders, remove any temporary construction, and do all work required to complete the erection in accordance with the Detailed Designs and the Technical Requirements. The Contractor shall not erect the precast concrete girders until the substructure concrete has been cured a minimum of three days and achieved 80% of the 28-day specified concrete strength requirements.

Without restricting generality, erection includes:

- Removing anchor bolt grout can lids;
- Placing and grouting anchor bolts and bearings;
- Erecting the girders;
- Placing and grouting of connector bolts and diaphragms;
- Post-tensioning;
- Placing and sealing grout bearing pads; and
- Cutting-off lifting hooks and grouting lifting holes on exterior girders and all lifting hook pockets.

300.5.9.10.2 Handling And Storing Materials

Girders to be stored shall be placed upright and shored on timber blocking and kept clean and properly drained.

300.5.9.10.3 Temporary Supporting Structures And Berms

The temporary supporting structures and berms shall be properly designed and substantially constructed and maintained for the forces which may come upon them. Berms shall be constructed in a manner and of such materials that they will not be eroded by stream flow nor introduce silt into the water. The Contractor shall prepare drawings for temporary supporting structures and berms, and for traffic control and accommodation where applicable. All drawings shall bear the seal of a Professional Engineer.

Temporary supporting structures and/or berms will not be permitted to remain in any stream channel during spring break-up or run-off periods, unless all necessary approvals have been obtained by the Contractor from pertinent agencies.

Incidental damage to other property, such as fills and stream banks, resulting from the existence of berms, shall be the responsibility of the Contractor.

300.5.9.10.4 Erection Procedure

The Contractor shall prepare a detailed erection procedure in advance of the scheduled start of erection. The erection procedure shall include all drawings and documents necessary to describe the following:

- (a) Access to work, earth berms and work bridges.
- (b) Type and capacity of equipment.
- (c) Sequence of operation, including position of cranes, trucks with girders, and traffic accommodation.

- (d) Detailed crane position on the ground, particularly adjacent to substructure elements, such as abutment backwalls, with details of load distribution on wheels and outriggers.
- (e) Details of crane position on the structure, showing wheel loads and axle spacing of equipment moving on structure.
- (f) Loads and their position from crane wheels and outriggers during all positions of lifting when crane is on structure.
- (g) Details of temporary works, supporting structure drawings, including proposed methods to be used to ensure the required splice elevations and structure shape prior to placing concrete, and/or post-tensioning and method of providing temporary supports for stability.
- (h) Details of lifting of units, showing vertical forces at lifting hooks.
- (i) Provisions for control and adjustment of errors for width and positioning of curbs or exterior units.
- (j) Complete details of blocking for bearings where necessary to constrain movements due to horizontal forces and/or gravity effects.
- (k) Details of post-tensioning procedures, including strand specifications, jack dimensions, pressures, forces and elongations, and grouting.
- (l) Grout pad construction (refer to Section 300.5.9.10.6 (Grout Pockets and Grout Pads)).
- (m) Details of release of temporary supporting structures.
- (n) Provide an “As Constructed” detailed survey of the substructure showing the following:
 - location and elevation of all bearing grout pad recesses;
 - shim height at each bearing location; and
 - top of girder elevations at each bearing (and each splice location where appropriate).

The erection procedure shall bear the seal of a Professional Engineer, who shall assume full responsibility to ensure that its design is being followed. Safety and compliance with the *Occupational Health and Safety Act* (Alberta) and regulations thereunder, shall be integral parts of the design.

The Contractor shall continue to be fully responsible for the results obtained by the use of these sealed drawings, with the Professional Engineer also assuming responsibility, as the Contractor’s agent, for the results obtained.

Before erection begins the Contractor shall do a complete superstructure layout by means of chalk lines and markings applied to all substructure units, showing bearing and girder positions in accordance with the approved layout plan.

300.5.9.10.5 Girder Adjustments

It is essential that the girders be erected with utmost attention being given to girder positioning, alignment, and elevation. The Contractor shall adjust girder position, bearing location and bearing elevation in order to achieve as closely as possible the lines and grades shown on the drawings. The Contractor shall minimize any differential camber (girder to girder), and the sweep of the girders, by jacking, loading of girders, winching, or whatever means are necessary, and shall provide the necessary temporary attachments to hold the girders in position.

The maximum dimensional deviation in mm, of erected precast concrete units from that as detailed on the drawings shall not exceed the following:

- Sweep (NU Girders) - 1 mm/m
- Sweep (Other Units) - deviation from true, $20 \text{ mm} \times \text{length (m)} \div 50$

300.5.9.10.6 Grout Pockets And Grout Pads

The Contractor shall construct grout pads using Sika 212 flowable grout or equivalent. Filling of grout pockets and construction of grout pads shall be done by workers competent in this work.

Grout shall be packaged in waterproof containers with the production date and shelf life of the material shown. It shall be mixed, placed, and cured in strict accordance with the manufacturer's recommendations.

Dry pack methods of constructing grout pads will not be accepted.

Sealer shall be applied to the exposed grout pad surfaces in accordance with Section 300.5.7.17 (Sealer).

300.5.9.10.7 Grouting In Cold Weather

When the daily minimum air temperature, or the temperature of the girders, bearings or substructure concrete, in the immediate area of the grouting, falls below 5°C, the following provisions for cold weather grouting shall be effected:

- (a) Before grouting, adequate preheat shall be provided to raise the temperature of the adjacent areas of the girders, bearings, and substructure concrete to at least 10°C.
- (b) Temperature of the grout during placing shall be between 10°C and 25°C.
- (c) The grout pads (or girders where appropriate) shall be enclosed and kept at 10°C to 25°C for at least five days. The system of heating shall be designed to prevent excessive drying-out of the grout.

300.5.9.10.8 Bearings and Anchorage

The Contractor shall remove anchor bolt void forming materials prior to grouting. Any residues on the concrete surface, such as oils, grease or other contaminants that can reduce bonding characteristics, shall be removed by sandblasting.

Anchor bolts shall be set accurately and grouted with a non-shrink cement grout. The location of the anchor bolts, in relation to the slotted holes in the expansion shoes, shall correspond with the temperature at the time of erection. The nuts on the anchor bolts, at the expansion ends of spans, shall be adjusted to permit free movement of the spans.

When steel bearings are employed in conjunction with grout pockets in the substructure, the bearings shall be set accurately on galvanized steel shims, and grouted as detailed on the drawings, after the erection has been completed. The shims must be located so that minimum 75 mm grout coverage is provided. When grout pockets are not detailed, the bearing plates shall be set on the properly finished bearing areas in exact position and shall have a full and even bearing on the concrete.

Where the design requires that the girders bear on neoprene pads placed directly on pier or abutment seat concrete, the Contractor shall supply and install shims cut from lead sheeting to ensure full and uniform bearing.

300.5.9.10.9 Assembly

The parts shall be accurately assembled as shown on the drawings. The material shall be carefully handled so that no parts will be distorted, broken or otherwise damaged. Bearing surfaces, and surfaces to be in permanent contact, shall be cleaned before the members are assembled. Diaphragms shall be erected as indicated on the drawings.

300.5.9.10.10 Lifting Hooks and Lifting Holes

After the girders are properly erected and positioned, all lifting holes on exterior girders shall be filled with an accepted grout; all lifting hooks shall be cut off 50 mm below surface, and all lifting hook pockets shall be filled with grout.

300.5.9.10.11 Painting of Metal Parts

All non-galvanized metal parts, including bearing surfaces not in contact, shall be painted two field coats of paint.

300.5.9.10.12 Post-Tensioning

300.5.9.10.12.1 General

This work consists of post-tensioning and grouting of cable ducts for cast-in-place and precast concrete.

300.5.9.10.12.2 Submissions

The following information shall be submitted to the Department:

- Post-tensioning drawings illustrating the stressing system and, where appropriate, design details and sequence of stressing (two copies);
- Stressing calculations taking into account all applicable losses (two copies);
- Load/elongation curves for the prestressing strand;
- Mill certificates for the prestressing strand; and
- Details of permanent anchoring devices.

300.5.9.10.12.3 Standards

Applicable requirements of the current edition of the following standards shall be followed:

- *CSA A23.1/23.2 – Concrete Materials and Method of Concrete Construction.*
- *CSA A23.4 – Precast Concrete Materials and Construction.*
- *Section 300.5.7 (Cast-in-Place Concrete).*
- *Guide Specification Acceptance Standards for Post Tensioning Systems – PTI*
- *Specifications for Grouting of Post Tensioned Structures - PTI*
- *AASHTO LRFD Bridge Construction Specifications*

300.5.9.10.12.4 Qualification

The Contractor, or its subcontractor, shall have extensive experience in this work and shall utilize only fully trained, competent and experienced operators. The Contractor shall ensure that the site supervisor responsible for the tensioning and grouting operations is at the site whenever these operations are being carried out.

300.5.9.10.12.5 Materials

(1) Prestressing Strand

Stressing strand shall conform to the requirements of Sections 300.5.9.6(9) (Prestressing Strand) and 300.5.9.7(3) (Stressing Strand).

Corrosion inhibitor is required when the stressing and grouting operations are not completed within 20 calendar days of the installation of the stressing steel. The corrosion inhibitor, when required, shall be water-soluble and shall have no deleterious effect on the steel, grout or concrete; or bond strength of steel to concrete.

(2) Anchorages And Distribution

All stressing steel shall be secured at the ends by means of permanent anchoring devices. These devices shall comply with *CAN/CSA S6-00* Clause 8.4.4.1.

Steel distribution plates or assemblies may be omitted when the anchoring devices are sufficiently large and used in conjunction with an embedded steel grillage that effectively distributes the compressive stresses to the concrete.

(3) Ducts

Ducts shall be corrugated, semi-rigid galvanized metal tubes and be capable of withstanding concrete pressures without excessive deformation or permitting the entrance of cement paste during the placement of concrete. The ducts shall have sufficient rigidity to maintain the required profile between points of supports. The interval between supports shall not exceed 1.0 m.

The Contractor shall provide mortar tight inlets and outlets in all ducts with a nominal diameter of 20 mm in the following locations:

- The anchorage area;
- All high points of the duct, when the vertical distance between the highest and lowest point is more than 500 mm;
- Place an inlet at or near the lowest point; and
- Place a free draining outlet at all low points of duct.

The Contractor shall provide inlets and outlets with valves, caps or other devices capable of withstanding the grouting pressure. The ducts and vents shall be securely fastened in place to prevent movement. The Contractor shall provide details of inlets and outlets on the shop drawings.

(4) Concrete

Concrete shall be supplied in accordance with Section 300.5.7 (Cast-in-Place Concrete), however the maximum size of coarse aggregate shall be 10 mm and the 28-day compressive strength shall be a minimum of 50 MPa.

(5) Grout

Grout shall be Class “B” or Class “C” as described in Table 10.9.3-1 and the properties as described in Table 10.9.3-2 of the *2002 Interim AASHTO LRFD Bridge Construction Specification*. The average minimum compressive strength of 3 cubes at 28 days shall be a minimum of 35 MPa as per CSA A23.2-1B.

300.5.9.10.12.6 Equipment

(1) Stressing

- Hydraulic jacks and pumps of sufficient capacity shall be used for tensioning of strands;
- The force induced in the prestressing strand shall be measured using calibrated jacking gauges, load cells or a calibrated dynamometer;
- The pressure gauge shall have an accurate reading dial at least 150 mm in diameter;
- The forces to be measured shall be within 25 and 75% of the total graduated capacity of the gauge, unless calibration data clearly establishes consistent accuracy over a wider range; and
- The measuring devices shall be calibrated at least once every six months. The jack and the gauge shall be calibrated as a unit. A certified calibration chart shall be kept with each gauge.

(2) **Grouting**

- A high speed shear mixer shall be used that is capable of continuous mechanical mixing and producing grout that is free of lumps and undispersed cement. The water supply to the mixer shall be measured by an accurate gauge;
- The holding tank shall be capable of keeping the mixed grout in continuous motion until it is used. The outlet to the pump shall have a screen with 3 mm maximum clear opening;
- A positive displacement type pump shall be used which is capable of producing an outlet pressure of at least 1.0 MPa. A pressure gauge having a full-scale reading of no greater than 2 MPa shall be placed at some point in the grout line between the pump outlet and the duct inlet. A spare fully functional pump shall also be on site;
- Standby flushing equipment with water supply shall be available at the site prior to commencing grouting;
- The grouting equipment shall be of sufficient capacity to ensure that grouting of the longest duct can be completed within 30 minutes after mixing; and
- Grout hoses and their rated pressure capacity shall be compatible with the pump output and the maximum grout pressure. All connections from the grout pump to the duct shall be airtight so that air cannot be drawn into the duct.

300.5.9.10.12.7 Construction

(1) **CHECKING POST TENSIONING DUCTS**

Prior to placing post-tensioning steel, the Contractor shall verify that all ducts are unobstructed.

(2) **WELDING**

Welding of stressing tendons shall not be permitted. Stressing tendons shall not be used as an electrical “ground”. Where the ends of strands are welded together to form a tendon so that the tendon may be pulled through the ducts, the length of the strands used as an electrical “ground” or 1.0 m, whichever is greater, shall be cut off from the welded end prior to stressing.

(3) **TENSIONING**

Post-tensioning shall be carried out as per the engineering drawings and stressing calculations. The stressing and release of tendons shall be done in the sequence specified on the Detailed Designs. All strands in each tendon shall be stressed simultaneously with a multi-strand jack. The force in the tendons shall be measured by means of pressure gauge and shall be verified by means of tendon elongation. All tendons shall be tensioned to a preliminary force as necessary to eliminate any slack in the tensioning system before elongation readings are started. This preliminary force shall be between 15 and 25 percent of the final jacking force.

Stressing tails of post-tensioned tendons shall not be cut off until the record of gauge pressures and tendon elongations has been reviewed by a Professional Engineer. A record of the following post-tensioning operations shall be kept for each tendon installed:

- Project Name and File Number;
- Subcontractor;
- Tendon location and size;

- Date tendon installed;
- Tendon pack/heat number;
- Modulus of elasticity (E);
- Date stressed;
- Jack and gauge identifier;
- Required jacking force and gauge pressures;
- Elongation (anticipated and actual);
- Anchor set (anticipated and actual);
- Stressing sequence;
- Witnesses to stressing operation;
- Grout information (Brand Name);
- Time for grouting each tendon; and
- Date grouted.

(4) CONCRETING

The anchorage recesses shall be concreted after tensioning but before grouting the tendons.

The concrete surface of the anchorage recesses shall be abrasive blasted. The recesses shall be thoroughly wetted and covered with a thin cement paste coating immediately before placing fresh concrete.

(5) GROUTING

All ducts or openings shall be clean and free of all deleterious matter that would impair bonding of the grout to the ducts and stressing steel. All ducts shall be thoroughly flushed out with water and blown out with compressed oil free air. All inlets and outlets shall be checked for their capacity to accept injection of grout by blowing compressed oil free air through the system.

A thoroughly mixed grout, meeting all the requirements described in Section 300.5.9.10.12.5(5) (Grout) shall be passed through a screen with 3 mm maximum clear openings before entering the pump. All grout vents shall be opened prior to commencement of grouting. The duct shall be completely filled by injecting grout from the lowest end of the tendon in an uphill direction. Grout shall be pumped continuously through the duct until no visible signs of water or air are ejected at the outlet. A fully operational grout pump shall be on site for all pumping procedures. A continuous, one way flow of grout shall be maintained at a rate of 5 to 15 lineal metres of duct per minute. The grouting of a tendon shall be completed within 30 minutes of mixing.

The pumping pressure at the injection vent shall not exceed 1 MPa. If the actual pressure exceeds the maximum allowed, the injection vent shall be closed and the grout shall be injected at the next vent that has been or is ready to be closed as long as one-way flow is maintained. Grout shall not be injected into a succeeding vent from which grout has not yet flowed. A fluidity test shall be performed on each tendon from the discharge outlet. The measured grout efflux time shall not be faster than the efflux time measured at the inlet or the minimum efflux time established. If the grout efflux time is not acceptable, additional grout shall be discharged from the discharge outlet. Grout efflux time shall be tested. This cycle shall be continued until acceptable grout fluidity is achieved. To ensure the tendon remains filled with grout, the ejection

and injection vents shall be closed in sequence, respectively under pressure when the tendon duct is completely filled with grout. Valves and caps are not to be removed until the grout has set.

Grouting will not be permitted when the air temperature is below 5°C or above 25°C, nor when there are other conditions that would be detrimental to the grouting operations.

The Contractor shall provide 50 mm deep grout tube termination recesses formed around the tubes projecting from top of the deck. After grouting, all tubes shall be cut flush with the bottom of the recesses, and the recesses shall then be grouted flush with the top of the deck.

300.5.9.10.13 Removal of Falsework and Site Clean-Up

Upon completion of the erection the Contractor shall remove all earth material or temporary supporting structures placed in the stream channel or elsewhere during construction. The Contractor shall remove all piling, excavated or surplus materials, rubbish and temporary buildings, replace or renew any damaged fences, and restore in an acceptable manner all property damaged during the execution of its work.

The Contractor shall leave the bridge site, roadway and adjacent property in a neat restored, and presentable condition, and when required, the Contractor shall provide written evidence that affected property owners or regulatory agencies have been satisfied.

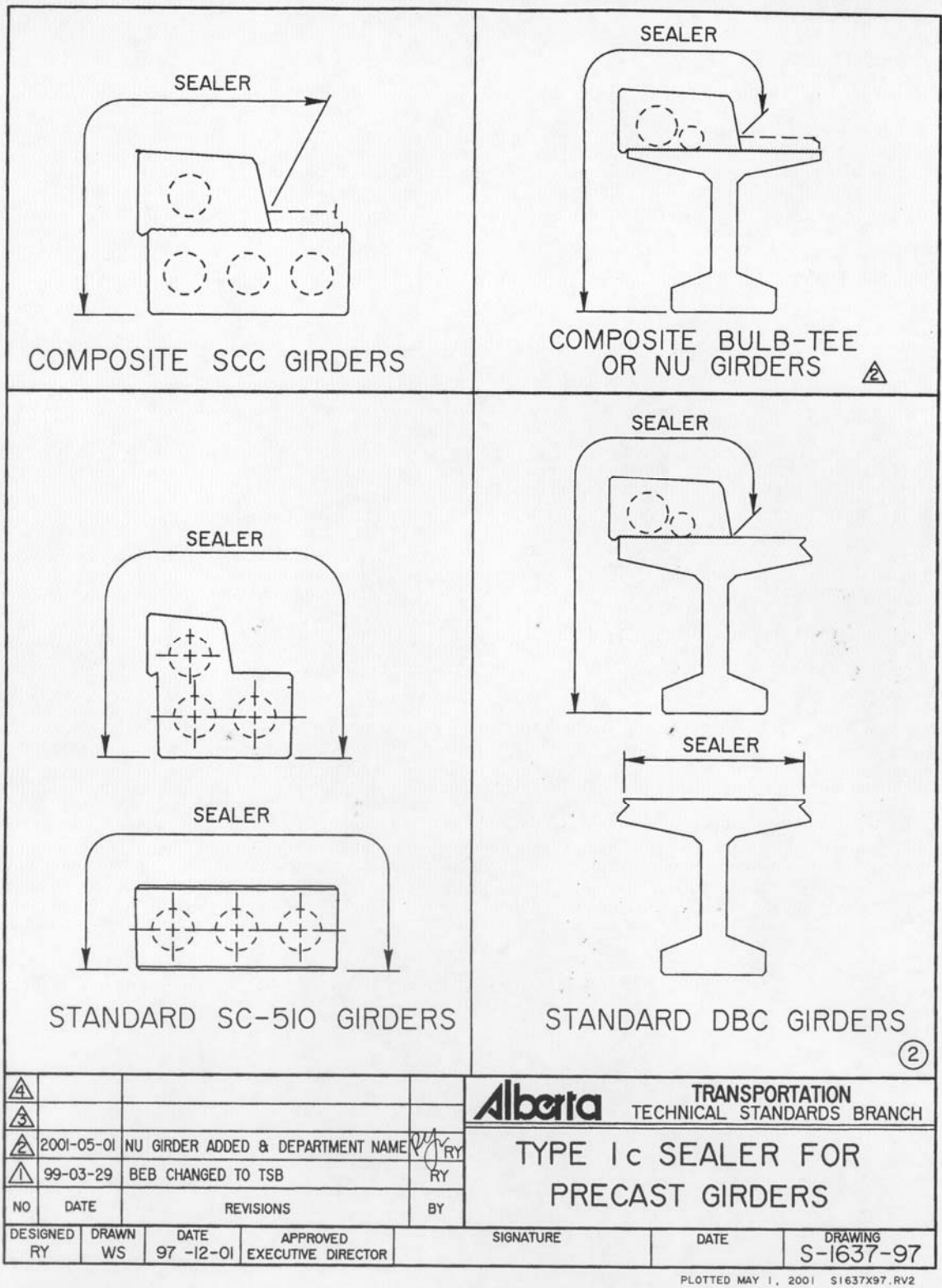

300.5.10 CONSTRUCTION OF CSP AND SPCSP STRUCTURES

300.5.10.1 General

This section describes the requirements for the supply, fabrication, delivery and installation of Corrugated Steel Pipe and Structural Plate Corrugated Steel Pipe with an equivalent diameter of 1.5 m or greater.

Abbreviations for the various types of metal pipe are as follows:

CSP	Corrugated Steel Pipe
CSP Arch	Corrugated Steel Pipe Arch
SPCSP	Structural Plate Corrugated Steel Pipe
SPCSP Arch	Structural Plate Corrugated Steel Pipe Arch

300.5.10.2 Submissions

The following information shall be submitted to the Department by the Contractor by a date that is reasonable having regard to the design and construction process and in any event no later than 21 days after request by the Department, acting reasonably:

- Shop drawings (two copies); and
- Dates fabricated materials are to be shipped from the fabricating plant. This information shall be provided to the Department a minimum of two days prior to shipping.

300.5.10.3 Reference Drawings (attached after Section 300.5.10.9)

Installation of Large Steel Pipes S1418-93

300.5.10.4 Reference Tables (attached after Section 300.5.10.9)

Details of Standard 2:1 Sloped End Sections for CSP Round Culverts	A
Details of Standard 2:1 Sloped End Sections for CSP Arch Culverts	B
Details of Standard 2:1 Sloped End Sections for SPCSP Round Culverts	C

300.5.10.5 Supply and Fabrication

300.5.10.5.1 Standards

The supply and fabrication of all galvanized, polymer coated and aluminium coated Corrugated Steel Pipe including couplers and appurtenances and Structural Plate Corrugated Steel Pipe shall

be in accordance with the current edition of CSA Standard G401 with additions and exceptions as described in this Section 300.5.10.

When specifying Double Zinc SPCSP & CSP, the zinc coating mass (total on both sides) shall be not less than $1,220 \text{ g/m}^2$ when tested by the triple spot test. The zinc coating mass shall be not less than $1,100 \text{ g/m}^2$ when tested by the single spot test.

300.5.10.5.2 Engineering Data

(1) Shop Drawings

Shop drawings for any non-standard materials (e.g. elbows, bottomless arch details, horizontal ellipses, etc.) as well as bevel end details for SPCSP shall be prepared.

(2) Plate Arrangement

The arrangement of the plates for SPCSP shall be shown so that the bolts in the valley of each longitudinal seam are nearer to the visible edge of the plate than the bolts in the crest, and in accordance with any plate combination and longitudinal seam stagger specified on the culvert order and/or construction drawings.

300.5.10.5.3 Materials

Previously installed pipe shall not be used. All pipe supplied shall be clearly marked with the following information at intervals of not less than 3 m.

- Manufacturer's Name or Trade Mark;
- Nominal Thickness and Type of Metal;
- Plate/Metal Coating (for non-standard coating);
- Specification Designation;
- Plant Designation Code; and
- Date of Manufacture.

300.5.10.5.4 Fabrication

(1) Fabrication of CSP

(a) Sloped Ends

Sloped end sections are required for each culvert unless otherwise shown in the Detailed Designs. When 2:1 sloped end sections are specified, the Reference Tables A and B (see Section 300.5.10.4) below will apply unless stated otherwise.

(b) Termination of Lockseams

On pipes 1.0 m diameter or larger all lockseams terminating at the cut edges of a sloped or square end section shall have a 75 mm length of fillet weld run along both sides of the lockseam (staggered 300 mm apart) at each cut edge. The weld and surrounding area shall be zinc coated in accordance with CSA G401.

(c) Cut Ends

All cut edges of a sloped or square end section shall be made smooth by grinding with all the burrs removed and the damaged zinc coating shall be repaired by application of a zinc-rich coating in accordance with CSA G401.

(d) Recorrugated Ends

All corrugated steel pipes shall have ends recorrugated to provide annular corrugations for couplers.

(e) Couplers

Only annular corrugated couplers will be accepted unless specified otherwise. The couplers for pipes 1.6 m and over in diameter shall be a minimum of 600 mm width. There shall be a minimum of five bolts per coupler.

(2) Fabrication of SPCSP

(a) Sloped Ends

Sloped end sections are required for each culvert unless otherwise noted on the Detailed Designs. When 2:1 sloped end sections are specified, the Reference Table C (see Section 300.5.10.4) below will apply unless stated otherwise.

300.5.10.5.5 Shop Inspection

(1) Inspection, Sampling and Testing

All materials shall be subject to inspection by the Department. The Contractor shall provide safe, convenient access acceptable to the Department for inspection and sampling of the materials, and shall cooperate in the inspection and sampling process when requested to do so.

(2) Notification

The Contractor shall contact the Department prior to contemplated shipment. This is to facilitate inspection of the materials at the plant.

300.5.10.5.6 Storage of Material

(1) Storage Stains

In addition to CSA G401, SPCSP material is to be stored concave down. This requirement is to reduce the occurrence of storage stain damage on plates that are not going to be assembled immediately.

300.5.10.5.7 Handling of Material

All culvert material shall be handled carefully and in such manner as to prevent bruising, scaling or breaking of the galvanized coating. Culvert material shall also be handled and unloaded without undue stress and in such a manner that the radii or dimensions of the pipes remain true. Coupling bands shall be shipped with all necessary hardware and fittings attached thereto, or in suitable shipping containers. All SPCSP bolts are to be shipped with plates. Where the material

supplied is damaged, the Contractor shall immediately separate nested sections of plate or pipe to facilitate more detailed inspection.

300.5.10.6 Installation

Metal pipes are flexible, and their resistance to deformation depends on careful bedding and backfilling. As they deflect under vertical load they must build up wide support and therefore, to obtain maximum load bearing capacity, it is essential that the material under and beside the pipe be of good quality, carefully placed and properly shaped and compacted as specified on the Detailed Designs. It is essential that the structure be kept dewatered to the bottom of the excavation until all backfilling is complete.

300.5.10.6.1 Bedding

Where the bottom of the excavation lies at 600 mm or less below the pipe invert the fill material shall be compacted by the Contractor to a minimum of 95% of Standard Proctor Density at optimum moisture content. Where the bottom of the excavation extends more than 600 mm below the pipe invert, the fill material shall be compacted at the 600 mm level to a minimum of 95% of Standard Proctor Density at optimum moisture content. The structural fill shall be placed in lifts not exceeding 150 mm when compacted. The Contractor shall use whatever materials, labour, equipment and incidentals necessary to achieve a stable bed.

When foundation conditions are considered soft and unstable, the Contractor shall supply and place woven geotextile filter fabric at the base of the excavation between the clay seals as shown on standard drawing S-1418-93 (see Section 300.5.10.3). The woven geotextile filter fabric shall be in accordance with the following table:

Woven Geotextile Filter Fabric	
Specifications and Physical Properties	
Grab Strength	1275N
Elongation (Failure)	15%
Puncture Strength	275 N
Burst Strength	3.6 MPa
Trapezoidal Tear	475 N
Minimum Fabric Lap to be 1.0 m	

The granular material within 150 mm of the bottom of pipe shall be placed in a loose uncompacted state. All other structural fill, including the clay seepage cutoffs, shall be compacted to a minimum of 95% of Standard Proctor Density at optimum moisture content.

The top of the bedding is that portion of the structural fill in contact with the bottom of the pipe and shall be constructed to the exact grade. Where camber is specified, the top of the bedding shall be constructed on a gradual crest curve with no sudden breaks in the grade. Where preshaping is specified, the top of the bedding shall be constructed to the exact curvature of the bottom plates. The top of the preshaping shall be 200 mm to 300 mm below the horizontal seam which joins the sidewall to the bottom plates, or as shown on the Detailed Designs.

300.5.10.6.2 Assembly

Assembly of CSP

CSP sections shall be laid so that the ends are in close contact. Couplers shall be well fitted and evenly tightened all around the pipe.

Assembly of SPCSP

SPCSP shall be assembled as shown on the drawings which will be provided by the pipe supplier and as outlined below:

- (a) All bolted seams shall be properly lapped and plates shall be in contact for the full width and length of the lap. The bolts in the valley of each longitudinal seam shall be nearer to the visible edge of the plate than the bolts in the crest.
- (b) After two complete rings have been loosely assembled, the vertical dimensions shall be checked and where necessary adjusted with horizontal cables and/or supports to obtain design rise dimensions.
- (c) Each adjacent ring shall then be assembled and adjusted in a similar manner until the entire structure is loosely assembled and conforms to design geometry with nested plates.
- (d) The vertical axis shall be upright and the longitudinal seams shall be straight. Rotation of the pipe and/or spiralling of the longitudinal seams shall not be permitted.
- (e) Adjustments shall be made to produce design dimensions with fully nested laps. When horizontal tie cables are used for shape adjustment, adequate means shall be taken to ensure distribution of concentrated forces at the pipe walls. Distortion of the pipe side walls at the cable points will not be tolerated.
- (f) Unless otherwise indicated by the manufacturer's specifications, bolts shall be torqued to not less than 200 Nm and not more than 340 Nm. This includes bolts which connect special features to the pipe.
- (g) Distortion of bolt holes caused by over-torquing, or poor assembly methods will not be permitted. Where additional holes are required they shall be drilled. Torch cutting of holes or welding on the pipe will not be permitted.
- (h) The shape of the pipe shall be maintained within two percent of design dimensions. This includes the rise, the span, and any chords or chord offsets.

300.5.10.6.3 Backfilling

When the assembly of the structure has been completed, backfilling with granular and or non-granular materials as specified on the drawings may proceed. In addition, the requirements set out in the four paragraphs below shall be met.

When the air temperature is below 0°C, no backfilling is allowed. All backfill materials shall be in a thawed state when placed and compacted. No backfill material will be permitted to be placed on frozen substrate.

The backfilling under the haunches shall be compacted in thin layers filling all corrugations and ensuring firm contact with the entire bottom surface of the pipe.

The backfilling shall fill each corrugation, be free of voids and provide uniform support to the pipe. The backfill shall be placed such that the level of fill on one side of the pipe does not exceed the level of fill on the other side of the pipe by more than 300 mm.

The Contractor shall supply suitable material for the compacted non-granular backfill. Generally the material shall consist of clay or till materials. Highly plastic clay material or material with a high silt content will not be permitted.

300.5.10.6.4 Strutting for Composite Concrete/SPCSP Structure

For composite concrete/SPCSP structures strutting and scaffolding shall be supplied and installed as shown on the Detailed Designs.

300.5.10.7 Concrete Work

Where detailed and specified, concrete work shall be constructed as shown on the Detailed Designs and in accordance with the relevant sections of Section 300.5 (Bridge Structures):

Section 300.5.7 - Cast-In-Place Concrete

Section 300.5.14 - Reinforcing Steel

300.5.10.8 Fish Baffles

Fish baffles shall be constructed as shown in the Detailed Designs.

300.5.10.9 Rock Riprap

Rock riprap shall be placed as shown in the Detailed Designs.

TABLE A
 DETAILS OF STANDARD 2:1 SLOPED END SECTIONS
 FOR CSP ROUND CULVERTS

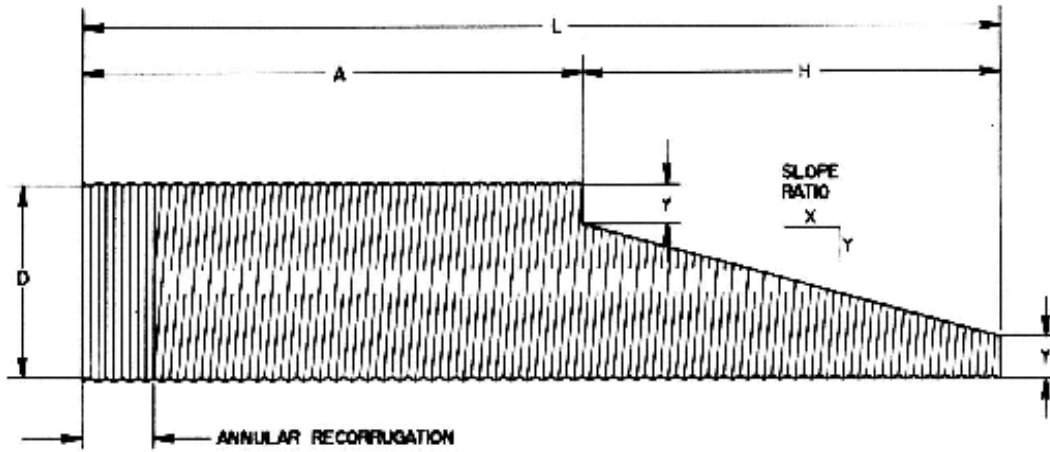

INSIDE DIAMETER D mm	SLOPE RATIO X:Y	Y mm	A m	H m	INVERT LENGTH OF SLOPED END SECTION L m
1200	2:1	150	4.2	1.800	6.0
1400	2:1	200	4.0	2.000	6.0
1600	2:1	200	3.6	2.400	6.0
1800	2:1	300	3.6	2.400	6.0
2000	2:1	300	5.2	2.800	8.0
2200	2:1	300	4.8	3.200	8.0
2400	2:1	400	4.8	3.200	8.0
2700	2:1	400	6.2	3.800	10.0
3000	2:1	500	6.0	4.000	10.0
3300	2:1	500	5.4	4.600	10.0
3600	2:1	600	5.2	4.800	10.0

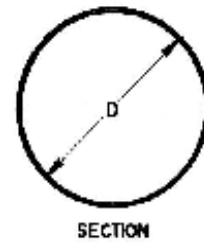
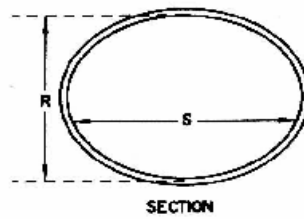
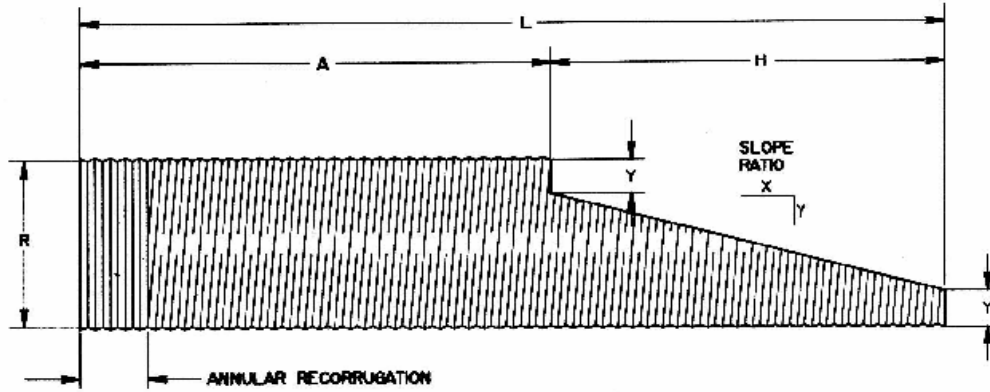

TABLE B
 DETAILS OF STANDARD 2:1 SLOPED END SECTIONS
 FOR CSP ARCH CULVERTS



EQUIVALENT INSIDE DIAMETER D* mm	SPAN S* mm	RISE R* mm	SLOPE RATIO X:Y	Y* mm	Z* m	Y* m	INVERT LENGTH OF SLOPED END SECTION L* m
1200	1390	970	2:1	150	4.660	1.340	6.0
1400	1630	1120	2:1	200	4.560	1.440	6.0
1600	1880	1260	2:1	250	4.480	1.520	6.0
1800	2130	1400	2:1	300	4.400	1.600	6.0

Graphics File: P:\web\manual\cb6\chape-515\revisions\cb6515ml.man

TABLE C
 DETAILS OF STANDARD 2:1 SLOPED END SECTIONS
 FOR SPCSP ROUND CULVERTS

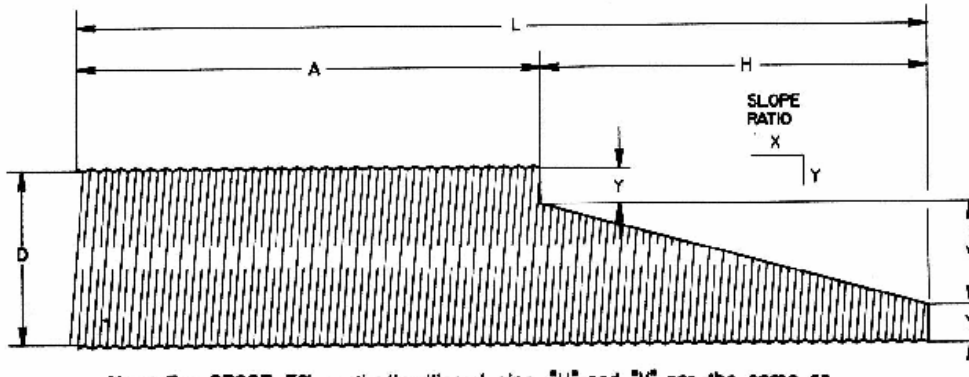

Note: For SPCSP 5% vertically ellipsed pipe; "H" and "Y" are the same as for a round pipe of equivalent diameter; "Y" is variable with the increase in rise.

INSIDE DIAMETER D - mm	SLOPE RATIO X:Y	Y - mm	Y - m
1500	2:1	293	1.928
1600	2:1	373	1.928
1810	2:1	295	2.440
1970	2:1	375	2.440
2120	2:1	298	3.048
2280	2:1	378	3.048
2430	2:1	453	3.048
2590	2:1	533	3.048
2740	2:1	455	3.658
3050	2:1	690	3.658
3360	2:1	765	3.658
3670	2:1	920	3.658
3990	2:1	1080	3.658
4300	2:1	1235	3.658
4610	2:1	1390	3.658
4920	2:1	936	6.096
5230	2:1	1091	6.096
5540	2:1	1246	6.096
5850	2:1	1095	7.320
6160	2:1	1250	7.320
6470	2:1	1405	7.320
6780	2:1	1560	7.320
7090	2:1	1715	7.320
7400	2:1	1870	7.320
7710	2:1	2025	7.320
8020	2:1	2180	7.320

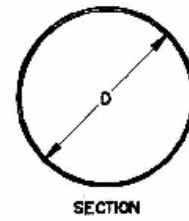

SECTION

Graphics File: P:\rep\manual\cb6\chapt - 5\5\revisions\cb65f5ml.mxd

300.5.11 INTENTIONALLY DELETED

300.5.12 SIGN STRUCTURES

300.5.12.1 General

This Section 300.5.12 is for the design, supply, fabrication, erection and all associated work pertaining to overhead and cantilevered sign structures and panels.

300.5.12.2 Submissions

The following information shall be submitted to the Department by a date that is reasonable having regard to the design and construction process and in any event no later than 21 days after request by the Department, acting reasonably:

- Shop drawings (two copies);
- Welding procedures for all welds;
- Proposed fabrication sequence and schedules. The Department shall be notified a minimum of two days prior to a component being ready for inspection at an inspection station;
- Mill certificates for all material;
- Repair procedures for unsatisfactory weldments and accidental arc strikes, if required;
- Product data sheets for coatings required between galvanized steel and concrete;
- Repair procedures for galvanizing, if required;
- The results of seam weld testing; and
- Method for forming and placing of grout.

300.5.12.3 Reference Drawings (attached after Section 300.5.12.7)

Sign Structure Steel Identification Plaque - S-1682-02

300.5.12.4 Engineering Data

(1) **Shop Drawings**

The shop drawings shall be legible and of adequate quality to be reproduced and microfilmed. All drawings shall be done on standard 11 x 17 or 22 x 34 sheet sizes. The shop drawings shall include the following:

- (a) The Department's Bridge File numbers, A-Ident numbers and project title, as provided by the Department, shall be shown on all the shop drawings.
- (b) Design criteria for each individual sign structure, including:
 - AASHTO Standard Specifications for Structural Supports for Highway Signs, Luminaires and Traffic Signals, 4th Edition and 2002 Interims;

- Initial sign panel area and/or minimum design sign panel areas;
 - Design wind pressure;
 - Fatigue category and fatigue loadings;
 - Design ice thickness;
 - Other dead loads;
 - Design temperature range;
 - Foundation soils parameters; and
 - Critical anchor bolt forces.
- (c) Each individual shop fabricated section or assembly shall be shown separately with complete and clearly identified welded or bolted details.
- (d) Weld procedure identification shall be shown on the shop drawings in the tail of the weld symbols.
- (e) All material splice locations shall be shown on the drawings.
- (f) Complete material list.
- (g) Erection procedure including tensioning procedure for anchor bolts.

300.5.12.5 Supply and Fabrication

300.5.12.5.1 Standards

Fabrication of sign structures shall conform to the *AASHTO Standard Specifications for Highway Bridges* and the *American Welding Society (“AWS”) - Bridge Welding Code, D1.5*.

Where imperial/metric conversions are necessary, The National Standard of Canada, CAN 3-Z234.1-79 shall be used as the basis of conversion.

All welding, cutting and preparation shall be in accordance with the American Welding Society (“AWS”) - *Bridge Welding Code, D1.5*, and D1.1 Section 10.

300.5.12.5.2 Qualification

The Contractor, or its subcontractor, shall operate a recognized steel fabricating shop and be fully approved by the CWB as per CSA W47.1.

Only welders, welding operators and tackers approved by the Canadian Welding Bureau in the particular category shall be permitted to perform weldments. Their qualifications shall be current and available for review by the Department.

300.5.12.5.3 Engineering Data

(1) **Welding Procedures**

Welding procedures shall be prepared for each type of weld used in the structure. The procedures shall bear the approval of the Canadian Welding Bureau.

(2) **Proposed Fabrication Sequence**

Prior to commencement of fabrication, the Contractor shall prepare an outline of the fabrication sequence that clearly describes the order of make-up and assembly of all the component parts, as well as shop assembly and inspection stations.

(3) **Mill Certificates**

Mill certificates shall be obtained for all material before fabrication commences.

(4) **Schedules**

The Contractor shall prepare and keep current a complete fabrication schedule.

300.5.12.5.4 Materials

- (a) All materials shall be new.
- (b) The use of aluminum is not acceptable.
- (c) Structural steel plate material shall conform to CSA -G40.21M 300W*
*Silicon content less than 0.04% for the shafts, whereas for flanges and base plates the silicon content shall be either less than 0.04% or between 0.15% to 0.25%.
- (d) All bolts, nuts and washers shall conform to ASTM A325 or shall meet property class 8.8 of the Industrial Fasteners Institute for metric high strength structural bolts, nuts and washers. Certified mill test reports for the fastener material shall be obtained.

Anchor bolts shall be fabricated from DYWIDAG thread bars conforming to the requirements of CSA G279.

All steel materials including all hardware and anchor bolts shall be hot-dip galvanized.

300.5.12.5.5 Welding

(1) **Filler Metals**

Low hydrogen filler, fluxes and low hydrogen welding practices shall be used throughout. The low hydrogen covering and flux shall be protected and stored as specified by AWS D1.5. Flux cored welding or use of cored filler wires in the submerged arc process or shielding gas processes are not considered as conforming to low hydrogen practice. These methods will not be permitted. However, metal core welding process utilizing low hydrogen electrodes with AWS designation of H4 will be allowed. The deposited weld metal shall provide strength, durability, impact toughness and corrosion resistance equivalent to base metal.

(2) **Cleaning Prior to Welding**

Weld areas must be clean, free of mill scale, dirt, grease, and other contaminants prior to welding.

(3) **Longitudinal Seams**

All longitudinal seams shall be made by a semi or fully automatic submerged arc or metal core welding process.

(4) Weld Penetration

The full penetration welds shall be completed using properly fitted backing bars or backgouged to sound metal. The longitudinal seams shall have a minimum 60% penetration; however if a backing bar is used for the longitudinal seam, the weld penetration shall be 90%. The following welds shall have 100% penetration:

- (a) Column to base plate.
- (b) Member to flange plate.
- (c) Flange plate to gusset plate.
- (d) Longitudinal seam welds within 150 mm of circumferential welds and 150 mm beyond hand holes (when provided) shall be full penetration groove welds. The transitions between full and partial penetration welds shall be ground smooth.
- (e) Backing bar splices.

The backing bars for full penetration welds shall be properly fitted and the member prepared to a sharp edged 45° chamfer. The groove weld shall be placed in a minimum of two passes by using 100°C of preheat (unless higher preheat is required as per AWS-D1.5) and maintain a root opening of 5 mm. A rod size no greater than 4.0 mm shall be used for the first pass. A reinforcing fillet weld shall be placed all around the joint.

(5) Tack and Temporary Welds

Tack and temporary welds shall not be allowed unless they are to be incorporated in the final weld. Tack welds, where allowed, shall be of a minimum length of four times the nominal size of the weld, and shall be subject to the same quality requirements as the final welds. Cracked tack welds shall be completely removed prior to welding over.

(6) Run-off Tabs

Run-off tabs shall be used at the ends of all welds that terminate at the edge of a member. They shall be tack welded only to that portion of the material that will not remain a part of the structure, or where the tack will be welded over and fused into the final joint. After welding, the tabs are to be removed by flame cutting, not by breaking off.

(7) Methods of Weldment Repair

Repair procedures for unsatisfactory weldments shall be prepared by a Professional Engineer experienced in welding prior to repair work commencing.

(8) Arc Strikes

Arc strikes will not be permitted. In the event of accidental arc strikes, the Contractor shall have a repair procedure prepared by a Professional Engineer. The repair procedure shall include the complete grinding out of the crater produced by the arc strike.

(9) Plug and Slot Welds

Plug welds or slot welds shall not be permitted.

300.5.12.5.6 Fabrication

Fabrication shall be performed in an enclosed area which is adequately heated. Field welding will not be allowed.

(1) Cutting of Plate

All plate material for main members and any plate material welded to the main member shall be flame cut using an automatic cutting machine. Shearing is not allowed.

(2) Additional Requirements

- (a) Each column, arm, extension, clamp and bracket shall be fabricated from one piece of sheet steel.
- (b) Intermediate circumferential butt welds will not be allowed, however horizontal members greater than 12 m span may have a bolted splice.
- (c) Columns, arms, extensions and clamps shall be brake press formed or roll formed. The brake press knife shall have a radius suitable for the thickness of the material and nature of the bend.
- (d) All plate edges shall be free of notches and gouges.
- (e) The depth or projection of any imperfections on the inner or outer surfaces shall not exceed 15% of wall thickness. Any depth or projection up to 33% of wall thickness may be repaired by welding. Any excessive projecting weld metal shall be removed.
- (f) The diameter of bolt holes in base plates shall be 10 mm larger than the bolt diameter.
- (g) Punching of full size holes will not be permitted. The holes shall be circular and perpendicular to the member and shall be deburred to ensure a proper faying surface.
- (h) Hand holes with cover plates are required on the top and bottom of columns of illuminated sign structures.
- (i) Hand hole (when required) shall be stiffened by providing a reinforcing rim with semi-circular ends. The rim shall be welded to the member with a full penetration groove weld supplemented with an all around fillet weld.
- (j) Only low stress stamps shall be used for identification marks. The stamps and specific location shall be shown on the shop drawings.

(3) Dimensional Tolerances

All fabrication shall meet the tolerances described below:

(a) Straightness

The straightness of any item shall not exceed the overall length divided by 300 from the surface at any point. This shall be measured with a straight line joining the surface at both ends. The difference between the straight line and the surface shall then be measured to determine the straightness.

(b) Twisting

The twist in the overall length of any column, arm, or extension shall not exceed 7°.

(c) Length

The specified length of any item shall be within 0 to 60 mm or -0 to +5% (whichever is less) with the exception of sign bridge spans which shall be within 5 mm of the specified dimensions in the unloaded condition. The tolerance for height shall be -0 to +60 mm.

(d) Across the Flat Dimensions

The average of all across the flats dimensions from a given cross section shall be within 1% of the specified dimension. In addition, the ratio of the maximum to minimum across the flats dimensions shall be less than or equal to 1.05.

(e) Tolerance for Flatness of Base Plates and Flange Plates

Surfaces of column base plates shall be flat to within 3 mm tolerance in 305 mm, and to within 5 mm tolerance overall. Faying surfaces of flange plates shall be flat to within 2 mm tolerance overall.

(f) Arm Rise

Arm rises apply to unloaded structure in the standing position.

(4) **Pre-Assembly**

After welding and fabrication but prior to galvanizing, the Contractor shall pre-assemble all structures complete with sign clamps to check the fit and geometry. Pre-assembled structures may be inspected by the Department.

The structures shall then be disassembled for galvanizing.

(5) **Galvanizing**

Galvanizing shall be by the hot dip method, after fabrication, in accordance with the current edition of CSA Standard G164 with additions and exceptions as described in this Section 300.5.12 (Sign Structures). The Contractor shall provide a smooth finish on all edges and surfaces, and remove all weld spatter and all welding flux residue from the steel components prior to galvanizing. Lumps, globules or heavy deposits of zinc will not be permitted. All threaded holes or threaded couplings shall be retapped after galvanizing.

Repair of galvanizing shall only be done if bare areas are infrequent, small, and suitable for repair. A detailed repair procedure shall be prepared by a Professional Engineer. It should be noted that repairs may require complete removal of the galvanized coating and regalvanizing. Repair shall be in compliance with ASTM A 780, Method A3 Metallizing. The thickness of the metallizing shall be 180 µm, and the repair tested for adhesion. The finished appearance shall be similar to the adjacent galvanizing.

(6) **Base Plate Corrosion Protection**

The bottom face of each base plate shall be protected by a medium grey colour barrier, to prevent contact between the zinc and the grout. The galvanized surface must be roughened prior to application of barrier coating. The surface preparation of the galvanized surface and the dry film thickness (“DFT”) of the coating shall be in accordance with the coating manufacturer’s recommendations. The Contractor shall test the adhesion of fully cured coating as per ASTM

D3359. The method selected for testing (Method A or B) shall depend on the dry film thickness of the coating. The coating manufacturer's product data sheets shall be obtained prior to the application of the coating. The adhesion test result shall meet a minimum of "4B" classification i.e. a maximum allowable flaking of 5%.

300.5.12.5.7 Testing and Inspection

(1) Access

The Contractor shall provide full facilities for the auditing of material and workmanship. Free access shall be allowed to the Department to all parts of the works. When required by the Department, the Contractor shall provide needed manpower for assistance in inspection duties.

(2) Testing by the Contractor

The Contractor shall provide quality control throughout the course of fabrication. All test records made by the fabricating shop in the course of normal quality control shall be open to the Department for inspection.

The Contractor shall arrange to have all full penetration welds inspected either by ultrasonic testing or radiographic inspection methods. Partial penetration seam welds shall be inspected by ultrasonic testing. The frequency of partial penetration weld inspections shall be three random locations per weld and the length of weld for ultrasonic inspection at each location shall be 200 mm. Calibration blocks for each thickness shall be prepared for ultrasonic testing to establish sensitivity levels and acceptance criteria. The NDT shall be done by a company certified to CAN/CSA W178.1. Ultrasonic and radiographic testing technicians shall be certified to Level II of CGSB.

(3) Testing by the Department

The Department may perform visual, radiographic, ultrasonic, magnetic particle and any other testing that may be required at its own expense.

(4) Inspection Station

To ensure that each stage of inspection is performed in an orderly manner, during the fabrication, inspection stations will be set up at specific points. Certain items of the work will then be checked, and deficiencies shall be corrected, prior to the work being sent to the next stage of fabrication. These check points shall be determined by the Contractor prior to commencement of fabrication.

(5) Non-destructive Methods of Examination

The methods of non-destructive examination shall be in accordance with the following standards:

- Radiography - AWS D1.5;
- Ultrasonic - AWS D1.5; and
- Magnetic Particle - ASTM E-709.

(6) Inspection Schedule

All welds will be visually inspected.

Ultrasonic inspection will be performed on full penetration welds.

300.5.12.5.8 Identification Tag

The Contractor shall supply and install an identification tag on one column of each structure at 2.4 m above base plate. The column shall be drilled and tapped for 2-10 mm diameter attachment bolts. The identification tag shall be fabricated as per Drawing S-1682-02 (see Section 300.5.12.3).

300.5.12.6 Erection

All product damaged in shipping shall be replaced.

The Contractor shall not erect the structural steel until the substructure concrete has been cured a minimum of three days and achieved 80% of the 28-day specified concrete strength requirement.

All components shall be handled with care to prevent stress to the components through bending or twisting. The use of steel chains as slings shall not be permitted. Any damage to the components through overstress, scratching or denting shall be repaired or replaced.

The structure shall be set accurately on galvanized shim plates. The shim plates must be located so that a minimum of 75 mm grout coverage is provided from shims to grout edge. The method of forming or pouring the grout shall be documented. Dry-pack methods of constructing grout pads will not be allowed.

Hand hole bolts shall be coated with anti-seize lubricant.

(1) High-Tensile-Strength Bolted Connections

Bolted parts shall fit solidly together when assembled. Contact surfaces shall be free of dirt, grease, burrs, pits and other defects that would prevent solid seating of the parts. Connections shall be assembled with a hardened washer under the bolt head or nut, whichever is the element turned in tightening. Surfaces of bolted parts in contact with the bolt head and nut shall be parallel.

(2) Bolt Tension

All structural bolts shall be tightened by using turn-of-nut method to provide bolt tension specified in Table 1 set out at the end of this Section 300.5.12.6. There shall first be enough bolts brought to a “snug tight” condition to ensure that the parts of the joint are brought into full contact with each other. Snug tight is defined as the tightness attained by a few impacts of an impact wrench or the full effort of a man using an ordinary spud wrench. Following this initial operation, bolts shall be placed in any remaining holes in the connection and brought to snug tightness. All bolts in the joint shall then be tightened additionally by the applicable amount of nut rotation specified below, with tightening progressing systematically from the most rigid part of the joint to its free edges. During this operation there shall be no rotation of the part not turned by the wrench.

Amount of rotation of nut relative to bolt, regardless of which is turned:

- 1/3 turn where bolt length is 4 bolt diameters or less;
- 1/2 turn where bolt length is over 4 bolt diameters and not exceeding 8 bolt diameters; and
- 2/3 turn where bolt length exceeds 8 bolt diameters.

Notes

- tolerance 1/6 turn (60°) over, nothing under; and
- length of bolt measured from underside of head.

Table 1 BOLT TENSION

Specified Bolt Size (A325M Bolts)	Minimum Bolt Tension		Commonly Supplied Equivalent Imperial Size (A325 Bolts)	Minimum Bolt Tension	
	Kilonewtons	pounds-force		Kilonewtons	pounds-force
M16X2	94	21,180	5/8	85	19,200
M20X2.5	147	33,050	3/4	126	28,400
M22X2.5	181	40,700	7/8	175	39,250
M24X3	212	47,660	1	227	51,500
--	--	--	1 1/8	251	56,450
M30X3.5	337	75,760	1 1/4	319	71,700
--	--	--	1 3/8	380	85,450
M36X4	490	110,160	1 1/2	463	104,000

300.5.12.7 Foundation

Where detailed and specified, concrete work shall be constructed as shown on the Detailed Designs and in accordance with the relevant sections of Section 300.5 (Bridge Structures):

Section 300.5.7 - Cast-In-Place Concrete

Section 300.5.13 - Piling

Section 300.5.14 - Reinforcing Steel

(1) Material

All reinforcing steel shall conform to CSA G30.18-M92 Grade 400.

All concrete shall be Modified Class C – 35 MPa, with type 50 sulphate resistance cement.

(2) Anchor Bolt Installation

Anchor bolt assemblies shall be supplied and installed in one complete assembly and consist of, but not be limited to, anchor bolts, c/w plate washers, full length sleeves filled with corrosion

inhibiting paste, top temporary templates, bottom anchor plates, bottom anchor nuts, thin clamping nuts, and all necessary hardware for post-tensioning and future de-tensioning. No welding of any component is allowed. Anchor bolts shall be true and plumb. Anchor bolts shall be post-tensioned to 70% of the ultimate strength after the grout pads have attained design strength. The top anchor nuts shall have plastic caps, and all voids including annular space in the base plate shall be filled with corrosion inhibiting paste. Sufficient anchor bolt projection shall remain for future work. All post-tensioning work and materials shall meet the requirements of Chapter 3 - Specifications of the PTI Post-Tensioning Manual.

(3) Grout Pockets and Grout Pads

The Contractor shall fill the grout pockets and construct the grout pads using Sika 212 flowable grout or equivalent. Filling of grout pockets and construction of grout pads shall be done by workers competent in this work. The grout pocket shall be 25 mm deep and the total grout thickness shall not be less than 75 mm.

Grout shall be packaged in waterproof containers with the production date and shelf life of the material shown. It shall be mixed, placed, and cured in strict accordance with the manufacturer's recommendations.

The method of forming and pouring the grout shall be documented. Dry-pack methods of constructing grout pads will not be allowed.

(4) Grouting in Cold Weather

When the daily minimum air temperature, or the temperature of the girders, bearings or substructure concrete, in the immediate area of the grouting, falls below 5°C, the following provisions for cold weather grouting shall be effected:

- (a) Before grouting, adequate preheat shall be provided to raise the temperature of the substructure concrete to at least 10°C.
- (b) Temperature of the grout during placing shall be between 10°C and 25°C.
- (c) The grout pads shall be enclosed and kept at 10°C to 25°C for at least five days. The system of heating shall be designed to prevent excessive drying-out of the grout.

(5) Clean-Up

All steel shall be left clean and free of oil, grease, mud, dust, road spray or other foreign matter.

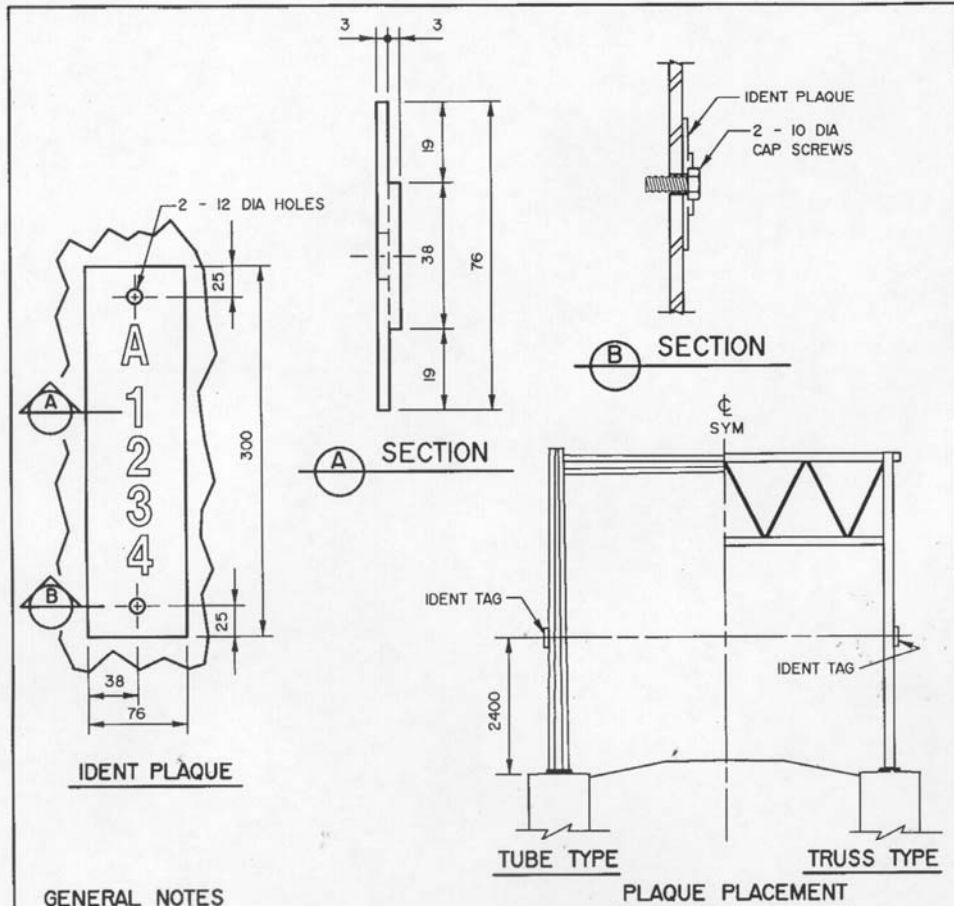

GENERAL NOTES

- DIMENSIONS ARE GIVEN IN mm. DETAILS ARE NOT TO SCALE. DIMENSIONS ARE TYPICAL UNLESS SHOWN OTHERWISE.
- THE A-IDENT NUMBER IS ISSUED BY ALBERTA TRANSPORTATION BRIDGE ENGINEERING SECTION, TECHNICAL STANDARDS BRANCH.
- PLAQUES SHALL BE CAST ALUMINUM. ALL SURFACES SHALL BE COVERED WITH BLACK BAKED ENAMEL EXCEPT FOR THE FULL FRONT BORDER & THE NUMERALS & LETTERS WHICH SHALL BE EXPOSED ALUMINUM.
- THE CONTRACTOR SHALL SUPPLY AND INSTALL AN IDENTIFICATION TAG ON ONE COLUMN OF EACH STRUCTURE AT 2.4 m ABOVE BASE PLATE. THE COLUMN SHALL BE DRILLED AND TAPPED FOR 2 - 10 mm DIAMETER CAP SCREWS.

				Alberta TRANSPORTATION TECHNICAL STANDARDS BRANCH			
				SIGN STRUCTURE STEEL IDENTIFICATION PLAQUE			
NO	DATE	REVISIONS	BY	SIGNATURE	DATE	PAGE	DRAWING
DESIGNED RY	DRAWN HW	DATE 2002-12-20	APPROVED EXECUTIVE DIRECTOR				S-1682-02

PLOTTED DECEMBER 20, 2002 51682x02.DGN

300.5.13 PILING

300.5.13.1 General

This Section 300.5.13 is for the supply and installation of steel H-piles, plain and galvanized steel pipe piles, precast concrete piles, and cast-in-place concrete piles. It includes driven bearing piles, drilled cast-in-place concrete bearing piles, and drilled cast-in-place concrete/steel pipe composite bearing piles.

300.5.13.2 Submittals

The following information shall be submitted to the Department by a date that is reasonable having regard to the design and construction process and in any event no later than 21 days after request by the Department, acting reasonably:

- Pile driving equipment and procedures to be used for the installation of driven piles; and
- Pile drilling equipment and procedures to be used for the installation of drilled piles.

300.5.13.3 Reference Drawings (attached after Section 300.5.13.7.8)

- Standard Pipe Pile Splice - S-1414-87
- Standard H-Pile Splice - S-1415-87
- Standard Closed Pipe Pile End Plate – S-1479

300.5.13.4 Materials

300.5.13.4.1 Steel "H" Piling

Steel "H" piling shall meet the requirements of Specification ASTM A36, CSA G40.21M 300W or better. Where piling is designated in metric dimensions, imperial equivalent piling will be acceptable. Mill certificates shall be obtained prior to pile installation.

Splice plates shall be fabricated to the dimensions shown on Standard Drawing S-1415-87 "Standard H-Pile Splice" (see Section 300.5.13.3).

300.5.13.4.2 Steel Pipe Piling

Steel pipe piling shall meet the requirements of Specification ASTM 252 Grade 2 or better, except that hydrostatic testing is not required. Although piling is designated in metric dimensions, imperial equivalent piling will be acceptable. Mill certificates shall be obtained

prior to pile installation. Some out-of-roundness of the pipe is acceptable provided an acceptable splice can be completed.

Galvanized piling shall be galvanized by the hot dip method, in accordance with CSA Standard G164.

Splice backup rings and closed pipe pile end plates shall be fabricated as shown on Standard Drawing S-1414-87 "Standard Pipe Pile Splice" and Standard Drawing 1479 "Standard Closed Pipe Pile End Plate" (see Section 300.5.13.3).

300.5.13.4.3 Timber Piling

The use of timber piling will not be permitted.

300.5.13.4.4 Pile Concrete

Concrete shall meet the requirements of Pile Concrete as specified in Section 300.5.7 (Cast-In-Place Concrete).

300.5.13.4.5 Reinforcing Steel

Steel reinforcement incorporated in the pile concrete shall meet the requirements specified in Section 300.5.14 (Reinforcing Steel).

300.5.13.5 Handling

Piling shall be handled, hauled and stored in a manner that avoids damage to the piling materials. Loading and unloading shall be by crane, loader or other appropriate hoisting equipment.

Care shall be taken in order to prevent damaging the galvanized surface on galvanized piling. Fabric slings, wood blocking or other approved methods shall be used to support and separate galvanized piling when handling, hauling or storing. Piling on which the galvanized coating has been damaged shall be replaced or repaired. Where repair of damaged galvanizing is required, the repair shall be by metallizing in conformance with ASTM A780, Method A3, to a thickness of 180 Φ m.

300.5.13.6 Driven Bearing Piles

300.5.13.6.1 Equipment and Driving Methods

Acceptable driving equipment is diesel hammers, vibratory hammers, or driving frames. The use of drop hammers will not be permitted under any circumstances.

The driving of piles with driving extensions shall be avoided if practicable. When driving extensions are used, one pile from each group of 10 shall be a long pile driven without extensions, and shall be used as a test pile to determine the average bearing power of the group. For the special types of piling, driving heads, mandrels, or other devices in accordance with the manufacturer's recommendations shall be provided so that the pile may be driven without damage and without unnecessary trimming.

Adequate precautions shall be taken to ensure that the piles are in proper alignment, including the use of such installation frames or other means as are necessary.

Piles shall be driven with a variation of not more than 20 mm per metre from the vertical or from the batter shown on the drawings, except that piles in exposed bents shall not be out of position at the ground line by more than 50 mm and shall not be out of position more than 25 mm in the pile cap. Foundation piles shall not be out of the position shown on the drawings more than 150 mm after driving.

300.5.13.6.2 Bearing Values

The piles shall all be driven to the tip elevations shown on the Detailed Designs, or lower, to achieve the required stability and specified minimum bearing capacity. The pile bearing capacities shall be estimated by the Bearing Formulas of this Section 300.5.13.6 (Driven Bearing Piles).

In the case of friction piles, the piles shall be driven to the tip elevations shown on the Detailed Designs, or lower, in order to achieve the required stability and design load carrying capacity.

Bearing Formulas

The safe bearing values for piles shall be determined by the following formulas:

For Diesel Hammers

$$P = \frac{165 \times E \times F}{S + 5}$$

Where P = safe bearing value (kilonewtons)
E = energy per blow (kilojoules)
F = efficiency factor

S = the average penetration per blow for the last 10 to 20 blows (mm per blow)

The efficiency factor of the hammer shall be determined at site, based on the performance of the hammer.

The above formula is applicable only when:

- (1) The head of the pile is not broomed, crushed, or deformed.
- (2) The penetration is reasonably quick and uniform.
- (3) A driving extension is not used.

300.5.13.6.3 Steel Piles

Steel piles shall consist of structural steel shapes or pipes of the section shown on the Detailed Designs or otherwise specified.

When pipe piles are to be driven closed-ended, one section of pipe for each proposed pile shall be supplied with the end-plate welded-on, in conformity with Standard Drawing S-1479 "Standard Closed Pipe Pile End Plate" (see Section 300.5.13.3).

When pipe piles are to be driven open-ended and the interiors cleaned out, a power screw rotary auger shall be used to remove the required material. All loose material and all material adhering to the walls of the piles shall be removed.

The total energy developed by the hammer shall be sufficient to achieve the required bearing value or tip elevation, but in no case shall the total energy developed be less than 35 kJ per blow.

The head shall be cut squarely and a driving cap or follower shall be provided to hold the axis of the pile in line with the axis of the hammer. The follower shall be of adequate dimensions to allow driving the pile without in any way trimming or reducing the cross-section of the pile. When end or tip damage or buckling is evident in obtaining the desired bearing capacity or penetration of the pile, the end or tip of the piling shall be reinforced, or, other suitable equipment or procedures provided, to prevent such damage.

Piles shall be cut off level at the required elevation. If capping is required, the connection shall be made according to details shown on the Detailed Designs.

When splicing, whatever means necessary shall be employed to match out-of-round piling. Exposed pile splices shall be avoided. Refer to Standard Drawing S-1415-87 "Standard H-Pile Splice" and Standard Drawing S-1414-87 "Standard Pipe Pile Splice" (see Section 300.5.13.3).

Where the upper portions of piling are specified to be galvanized, excess piling shall be removed from the ungalvanized portion of the piling to ensure that the galvanized portion extends to the elevation shown on the Detailed Designs. Splicing within the galvanized portion of the piling

shall be avoided; however if splicing becomes necessary due to unforeseen circumstances, the damage galvanized area shall be metallized.

Site welding personnel shall be advised of the hazardous fumes which are generated during welding or cutting of the galvanized steel.

Temporary caps shall be supplied and secured on all open pipe piles or drilled holes.

300.5.13.6.4 Defective Piles

The procedure incident to the driving of piles shall not subject them to excessive and undue abuse producing deformation of the steel, or crushing and spalling of the concrete. Piles damaged by improper driving, or driven out of proper location, or driven below the cut-off elevation, shall be corrected by one of the following methods:

- (a) The piles shall be withdrawn and replaced by new and, if necessary, longer piles, or
- (b) replacement piles shall be driven adjacent to defective or low piles, or
- (c) the piles shall be spliced or built up, as otherwise provided herein, or a sufficient portion of the footing extended to properly embed the piles. All piles, pushed up by the driving of adjacent piles or by any other cause, shall be driven down again.

In case the required penetration and bearing capacity are not obtained, the Contractor may provide a hammer of greater energy or resort to pre-drilling.

300.5.13.7 Drilled Cast-in-place Concrete Bearing Piles

300.5.13.7.1 General

In addition to drilled cast-in-place concrete bearing piles this Section 300.5.13.7 shall include drilled cast-in-place concrete/steel pipe composite bearing piles. The work shall include drilling and belling the holes, as required, supplying and placing the steel pipe and reinforcing steel, and supplying, placing, protecting and curing the concrete.

300.5.13.7.2 Equipment and Drilling Methods

Due to the nature of the work, the drilling subcontractor shall have adequate equipment and a proven record of competence in this work.

Only powered screw rotary type augers will be acceptable for drilling.

The installation of further piling shall not proceed if for any reason, the quality of the adjacent piling is compromised due to the effects of vibration or other reasons.

300.5.13.7.3 Drilling Pile Holes

The drilled pile holes shall be stabilized and sealed by means of temporary casings or other methods to prevent the possible collapse of the pile holes or ingress of water. Every attempt necessary shall be made to obtain "dry" pile holes prior to placing the pile concrete.

Temporary casing, if used in drilling operations, shall be removed from the hole as pile concrete is being poured. The bottom of the casing shall be maintained below the top of the concrete during withdrawal and pouring operations. Separation of the concrete during withdrawal operations shall be avoided by hammering or otherwise vibrating the casing.

The elevations shown on the Detailed Designs of the bottoms of the pile holes shall be considered approximate only, and further drilling may be required as necessary to secure satisfactory bearing of the piles.

Where bellling of the piles is specified, bellling shall proceed only after the pile hole has been drilled to the specified elevation.

The walls and bottoms of the pile holes shall be cleaned to remove all loose and extraneous material. The presence of any gas shall be determined and appropriate means and equipment shall be employed to ensure a safe work site. Pile reinforcement and pile concrete shall not be placed until the pile hole is deemed acceptable.

300.5.13.7.4 Open Drilled Holes

All open drilled holes on the site shall be covered until the time they are filled with concrete or otherwise properly backfilled. The covers shall be of adequate strength and securely fitted so that machinery and workmen are protected against cave-in and surface water is prevented from running into the pile hole.

300.5.13.7.5 Reinforcement

Steel reinforcement shall be fabricated in the sizes and to the dimensions shown on the Detailed Designs and shall be placed, centered and braced in the pile hole as detailed.

Particular care shall be taken in locating projecting "column dowel bars", to a tolerance not exceeding 10 mm in any direction, and pouring will not be permitted until provisions are made to confirm to this requirement.

Adequate "shoes" or spacers shall be firmly anchored to the reinforcement to ensure the reinforcement is kept centered in the concrete.

300.5.13.7.6 Concrete Placement

When the reinforcement has been acceptably placed, concrete shall be immediately deposited in the pile hole. The concrete shall be "Pile Concrete" and the provisions of Section 300.5.7 (Cast-In-Place Concrete) shall apply.

Suitable forms shall be used to maintain the specified dimensions of concrete piles above ground level.

300.5.13.7.7 Cold Weather Conditions

In cold weather, which shall be considered to exist if nighttime low temperatures are expected to be below 0EC, heated concrete shall be used. Such concrete shall have a temperature of between 15EC and 25EC when placed.

When the ground against which pile concrete is placed is below -5EC, the concrete shall be protected from heat loss. The pile boring shall be made oversize down to the depth of 2 m, and the concrete shall be poured in an insulated form. Concrete at the top of the pile is to be insulated. After four days the form and insulation may be removed, and the space is to be backfilled immediately with compacted non-granular fill or lean concrete to the elevation of top of pile.

In a region where the ground temperature is above -10EC but below -5EC, the hole may be bored 100 mm diameter oversize, and filled directly with pile concrete, as an alternative to the procedure described above. Concrete at the top of the pile is to be insulated.

If the top of the pile extends above the existing ground surface, in cold weather, it is to be adequately protected from the cold for a period long enough to ensure proper curing.

300.5.13.7.8 Pile Tolerance

Piles shall be accurately located, and shall be installed plumb or at the batter specified on the Detailed Designs. The maximum tolerance allowed shall be 50 mm for variation off the centre of any pile at the cut-off elevation, and no pile shall be out of plumb or specified batter by more than 20 mm per metre. Any pile out of centre or plumb beyond the tolerances specified shall be corrected.

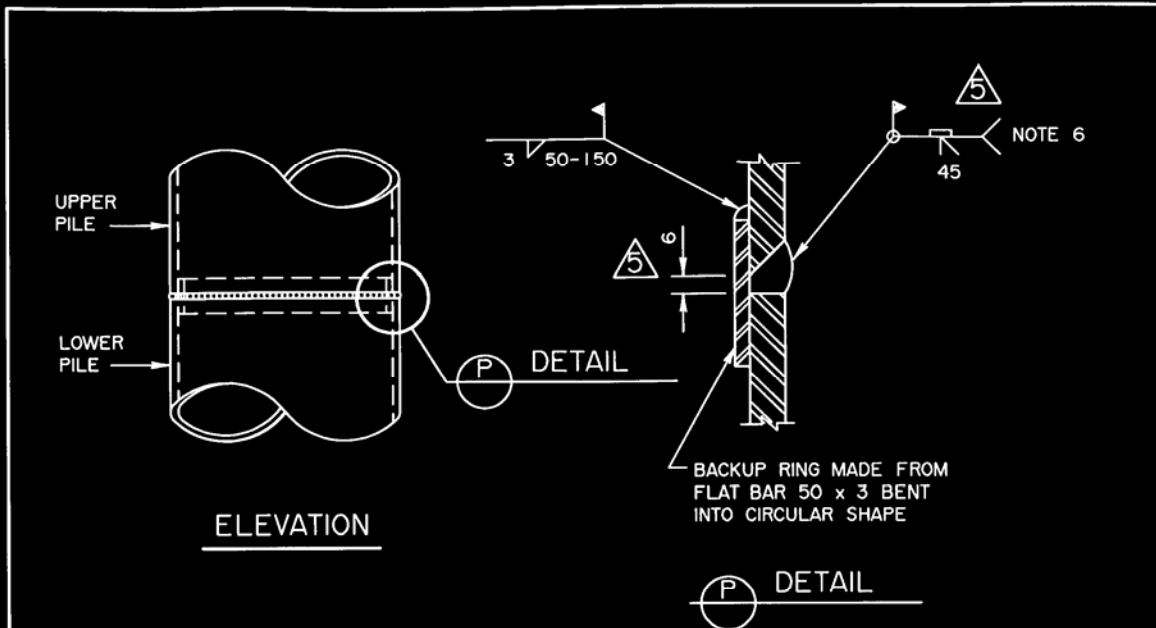

GENERAL NOTES

- DIMENSIONS ARE GIVEN IN mm. DETAILS ARE NOT TO SCALE

2

REQUIREMENTS AND PROCEDURE FOR SPLICING PIPE PILES

4

1. FIELD WELDING SHALL BE IN ACCORDANCE WITH SECTION 13.4
2. THE LOWER PILE SHALL BE TRIMMED TRUE AND SQUARE.
3. THE BEVEL ON THE UPPER PILE SHALL BE FLAME CUT USING A MECHANICAL PIPE BEVELLING MACHINE.
4. THE BACKUP PLATE SHALL BE WELDED TO THE UPPER PILE.
5. THE UPPER PILE SHALL BE POSITIONED WITH THE BACKUP RING FITTED INTO THE LOWER PILE.
6. SPLICE WELD SHALL PENETRATE BACKUP RING. TWO PASSES ARE REQUIRED IF THE PILE WALL IS GREATER THAN 8 mm. GRIND WELD SMOOTH IF THE SPLICE IS LOCATED ABOVE GROUND LEVEL.

2005-05-19	DETAIL "P" REVISED	AW					
2001-06-19	GENERAL NOTES	AW					
99-03-29	BEB CHANGED TO TSB	RY					
94-11-30	GENERAL NOTES	RJR					
87-03-09	REDRAWN FROM S-1414	DHQ					
NO	DATE	REVISIONS					
DESIGNED	DRAWN	DATE	APPROVED	SIGNATURE	DATE	PAGE	DRAWING
DHQ	MIK	87-03-09	EXECUTIVE DIRECTOR	<i>[Signature]</i>	11/18/87	3.15	S-1414-87

Alberta TRANSPORTATION AND UTILITIES
TECHNICAL STANDARDS BRANCH

**STANDARD
PIPE PILE SPLICE**

PLOTTED MAY 19, 2005 51414X87.RV5

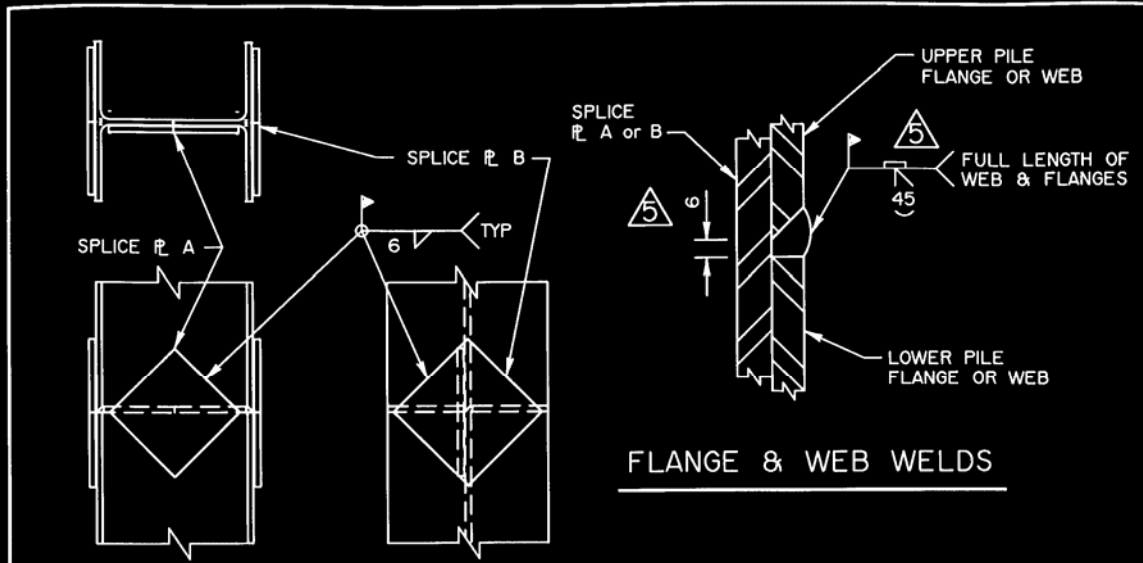

SPLICE DETAILS

PILE DESIGNATION	SPLICE PLATE DIMENSIONS	
	PLATE A (WEB)	PLATE B (FLANGE)
HP 250 x 62	140 x 10 x 140	170 x 10 x 170
HP 310 x 94	175 x 12 x 175	200 x 12 x 200
HP 360 x 132	200 x 16 x 200	250 x 16 x 250

GENERAL NOTES

- DIMENSIONS ARE GIVEN IN mm. DETAILS ARE NOT TO SCALE.
- ② • STEEL SHALL CONFORM TO ASTM A36 OR CSA G40.21M 300W.

REQUIREMENTS AND PROCEDURE FOR SPLICING H-PILES

- ④ 1. FIELD WELDING SHALL BE IN ACCORDANCE WITH SECTION I3.4
- 2. PILE ENDS TO BE SPLICED SHALL BE FLAME CUT USING A STEEL GUIDE TO OBTAIN A SQUARE AND EVEN CUT. BEVEL CUTS SHALL BE MADE AT 45°.
- 3. SPLICE PLATES A & B SHALL BE WELDED TO THE UPPER PILE BEFORE POSITIONING IT.
- 4. THE UPPER PILE SHALL BE POSITIONED ON AND THE SPLICE PLATES WELDED TO THE LOWER PILE; BUTT WELDS SHALL THEN BE MADE.

③	2005-05-19	FLANGE & WEB WELDS REVISED	AW
③	2001-06-19	GENERAL NOTES	AW
③	99-03-29	BEB CHANGED TO TSB	RY
③	94-11-30	GENERAL NOTES	RJR
③	87-03-11	REDRAWN FROM S-1415	DHQ
NO	DATE	REVISIONS	BY

Alberta TRANSPORTATION AND UTILITIES
TECHNICAL STANDARDS BRANCH

**STANDARD
H-PILE SPLICE**

DESIGNED DHQ	DRAWN MIK	DATE 87-03-11	APPROVED EXECUTIVE DIRECTOR	SIGNATURE <i>[Signature]</i>	DATE 11/4/87	PAGE 3.13	DRAWING S-1415-87
-----------------	--------------	------------------	--------------------------------	---------------------------------	-----------------	--------------	----------------------

PLOTTED MAY 19, 2005 S1415X87.RV4

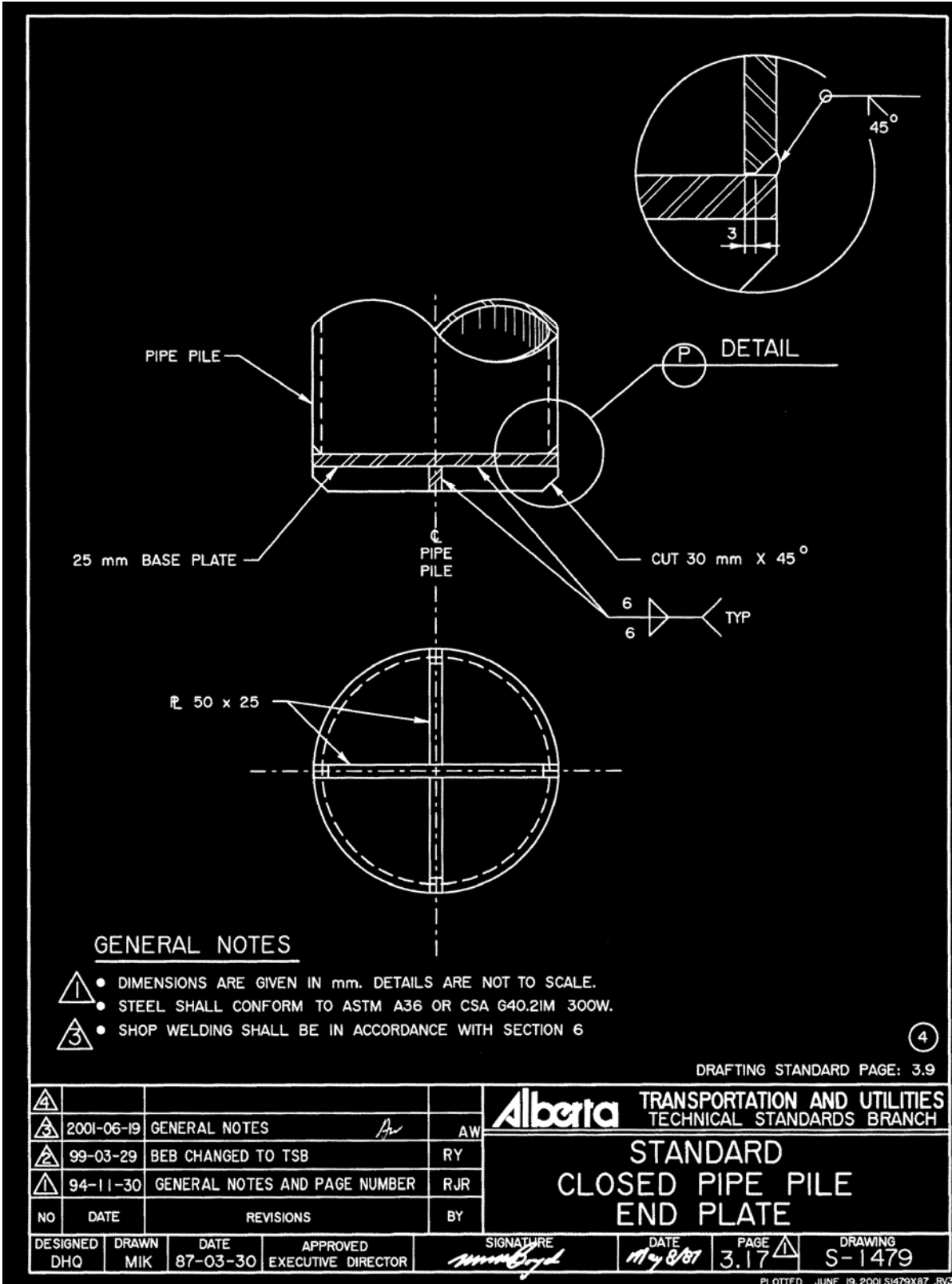

300.5.14 REINFORCING STEEL

300.5.14.1 General

This Section 300.5.14 is for the supply, fabrication, handling and placing of reinforcing steel. Reinforcement bars shall be supplied in the lengths and shapes, and installed as indicated on the Detailed Designs.

300.5.14.2 Certification

Epoxy-coated reinforcing steel shall be coated by a manufacturer certified under the Concrete Reinforcing Steel Institute (CRSI) Voluntary Certification program for Fusion-Bonded Epoxy Coating Applicator plants.

300.5.14.3 Fabrication

Reinforcing steel shall conform to the requirements of the CSA Standard G30.18M Grade 400. All hooks and bends shall be bent using the pin diameters and dimensions as recommended in The Reinforcing Steel Institute of Canada, (RSIC), Manual of Standard Practice, 1 Sparks Avenue, Willowdale, Ontario M2H 2W1, Phone: 416-499-4000, unless specified otherwise. Reinforcing bars shall conform accurately to the dimensions shown on the Detailed Designs and within the fabricating tolerance as shown in the RSIC, Manual of Standard Practice.

Epoxy-coated reinforcing steel shall be prepared and coated according to the requirements of ASTM A775 and the Ontario Provincial Standard Specification OPSS 1442, Material Specification for Epoxy-coated Steel Reinforcement for Concrete with additions and exceptions as described in this Section 300.5.14. Film thickness of the coating, after curing, shall be 175 Φ m to 300 Φ m (7 to 12 mils). The epoxy coating material shall conform to the requirements of OPSS 1443, Material Specification for Organic Coatings for Steel Reinforcement.

Mesh reinforcement shall be supplied in flat sheets only.

300.5.14.4 Handling and Storage

Steel reinforcement shall be stored above the surface of the ground, upon platforms, skids, or other supports, and protected from mechanical injury and surface deterioration caused by exposure to conditions producing rust. Steel reinforcement incorporated in the work shall be free from loose rust, scale, dirt, paint, oil, and other foreign material.

Special care shall be taken when handling epoxy-coated reinforcing steel to prevent damage to the epoxy coating. Epoxy-coated reinforcing bars shall not be dropped or dragged, and shall be lifted with non-metallic slings. Bar-to-bar abrasion and excessive sagging of bundles must be prevented, and bundles shall be handled with spreaders and non-metallic slings.

On site storage of the epoxy-coated reinforcing steel shall not exceed 120 days, and exposure to daylight shall not exceed 30 days. If the exposure time is expected to exceed 30 days, the reinforcing steel shall be protected by covering with opaque polyethylene sheeting or equivalent protective material.

300.5.14.5 Field Repair of Epoxy Coating

All damage to epoxy coating shall be field repaired up to the time the reinforcing steel is incorporated into the concrete structure, whether the damage is due to field cutting or handling damage. Where field cutting of the epoxy-coated reinforcing steel is necessary, it shall be either sheared or saw cut.

Repair of damaged coating, sheared or sawed ends shall be done using the epoxy coating supplier's approved patching material and in accordance with the patching material manufacturer's written recommendations regarding surface preparation and patching material application. At a minimum the areas to be repaired shall be cleaned by removing all surface contaminants and damaged coating before applying patching material. Where rust is present, it shall be entirely removed immediately before applying the patching material. The patching material shall be overlapped onto the original coating for 25 mm or as recommended by the manufacturer. The dry film thickness of the patched areas shall be between 175 Φ m to 300 Φ m. When the field repairs result in a total bar surface area covered by patching material that exceeds 5% of the bar surface area, the bar shall be replaced.

300.5.14.6 Placing and Fastening

All steel reinforcement shall be accurately placed in the positions shown on the Detailed Designs, and firmly tied and chaired before placing the concrete. When placed in the work it shall be free from dirt, detrimental rust, loose scale, paint, oil or other foreign material. Bars shall be tied at all intersections, except where spacing is less than 250 mm in each direction, when alternate intersections shall be tied. Tack welding of reinforcing steel shall not be allowed.

Distances from the forms shall be maintained by means of stays, spacers, or other approved supports. Spacers for securing reinforcement from contact with the forms or for separation between layers of bars shall be plastic chairs, precast concrete supports, galvanized metal or epoxy-coated metal, of acceptable shape and dimensions. Precast concrete supports shall have compressive strengths equal to or exceeding the placed

concrete. Tie-wire for epoxy coated reinforcing shall be plastic coated. Any metal chairs protruding through the surface of the hardened concrete shall be cut back at least 25 mm, and the holes filled in accordance with Section 300.5.7.16.2 (Class 1 Ordinary Surface Finish). Metal chairs shall not be used to support reinforcement on surfaces which are to be exposed or are to be finished; where possible, this reinforcement is to be supported entirely from above.

300.5.14.7 Splicing

Splices, where possible, shall be staggered.

For lapped splices, the bars shall be placed in contact and wired together in such a manner as to maintain a clearance of not less than the required minimum clear distance to other bars, and the required minimum distance to the surface of the concrete. In general, suitable lap lengths will be achieved by the placing of bars of the lengths as set out in the Detailed Designs.

Sheets of mesh or bar mat reinforcement shall overlap each other sufficiently to maintain a uniform strength and shall be securely fastened at the ends and edges. The edge lap shall not be less than one mesh in width.

300.5.15 WATERPROOFING MEMBRANE

300.5.15.1 General

This Section 300.5.15 shall include the supply and installation of an approved waterproof asphaltic membrane as shown on Standard Drawings S-1443-98 (see Section 300.5.15.2). The area to be covered by the waterproofing shall be as shown on the Detailed Designs.

300.5.15.2 Reference Drawings (as attached after Section 300.5.15.9.3.4)

- Deck Waterproofing System with 80 mm Two-Course Hot-Mix Asphalt Concrete Pavement S-1443-98.

300.5.15.3 Materials

All materials for this application shall be from the List of Approved Materials (see Section 300.5.15.7). No substitutions will be made without the prior approval of the Department.

Tack Coat

The tack coat used in conjunction with the asphalt membrane shall be primer, cut back with an equal volume of gasoline type solvent, or an acceptable alternative cut-back asphalt product and be compatible with the asphalt membrane.

Asphalt Membrane

Asphalt membrane shall be hot applied rubberized asphalt and shall be supplied in cakes ready for melting and application.

Rubber Membrane

The rubber membrane shall be 1.2 mm thick butyl rubber.

Waterproofing Protection Board

The protection board shall be a durable panel of 3 mm thickness specifically designed to provide a protective cushion between the hot mix asphaltic concrete pavement and the asphalt waterproofing membrane. It shall have a water absorption property of 5% or less and shall meet the Ontario Ministry of Transportation and Communications Material Specification for Protection Board.

300.5.15.4 Equipment

An acceptable heating and mixing kettle shall be used to heat the hot-applied rubberized asphalt membrane. The kettle shall be of the double boiler oil transfer type with a built-in agitator and equipped with permanently installed dial type thermometers to measure the temperature of the melted compound and the oil.

300.5.15.5 Installation

300.5.15.5.1 Traffic Restrictions

Traffic restrictions apply to all traffic other than the construction equipment directly associated with the waterproofing operations and the paving operations that follow.

After sandblasting operations have commenced, construction traffic will not be allowed on the sandblasted area until the ACP has been placed and cooled to ambient temperature.

300.5.15.5.2 Procedure

All of the operations involved in waterproofing shall be performed in sequential order, such that there are no delays between individual operations except those necessary to meet the requirements of this Section 300.5.15.

300.5.15.5.3 Surface Preparation

The deck concrete, including curbs, sidewalks and medians must be completely dry and cured at least 14 days before application of tack or membrane can proceed.

The existing surface of the concrete shall be completely sandblasted or shotblasted to expose sound, laitance-free concrete. All dirt and debris shall be removed and disposed of, leaving a prepared surface satisfactory for tack coating. Tack coating and waterproofing shall not commence until the concrete surface is fully cleaned.

Immediately prior to the application of the tack coat, the concrete surface shall be air blasted to remove all dust and any other foreign material. The tack coat shall be cut back 50% with gasoline solvent. The application rate shall be such that the tack material will be absorbed into the concrete, resulting in a surface that is dull and black in appearance. The application of an excessive amount of tack as indicated by a shiny black surface shall be avoided. Tack coat material shall be applied with approved equipment which will provide uniform application at the required rate. The tack coat shall be applied only when the concrete is dry and clean, and when the air and concrete surface temperatures are above 5EC. Waterproofing equipment or material shall not be permitted on the tack coat until it has fully cured and is completely tack-free.

300.5.15.5.4 Waterproofing of Joints and Cracks

Special attention shall be paid to waterproofing over all construction joints, and over any cracks that would not be bridged by the asphalt membrane.

Prior to the application of the asphalt membrane to the deck, a coat of hot asphalt membrane at least 4 mm thick and wide enough to extend 200 mm on either side of the joint or crack shall be applied in accordance with Section 300.5.15.5.7 (Application of Protection Board) to the tack-coated concrete surface. A strip of butyl rubber membrane material wide enough to extend 150 mm on either side of the joint or crack shall be applied while the asphalt membrane is still hot. Along all curbs, barrier walls, and deck drains the hot asphalt membrane shall be applied to the height of the top of the hot mix surface course, and 150 mm onto the deck. The rubber membrane shall extend 40 mm up the vertical faces, and 110 mm onto the deck surface.

300.5.15.5.5 Waterproofing Around Deck Drip Tubes

Special attention shall be paid to waterproofing around the deck drip tubes. The asphalt membrane shall be carefully applied around the drain tubes so that a positive seal is obtained. (It may be necessary to temporarily plug the tubes prior to waterproofing in order to prevent the entrance of hot membrane.) The tubes shall be trimmed flush with the top of the membrane to allow free drainage of water.

300.5.15.5.6 Application of Asphalt Membrane

Cakes of asphalt membrane shall be melted in the mechanically agitated heating and mixing unit specified. This unit shall keep the contents continuously agitated until the material can be drawn free flowing and lump-free from the mixing unit at a temperature not exceeding that recommended by the manufacturer.

Membrane shall not be applied until the tack coat has cured completely. The asphalt membrane shall be applied within the temperature range recommended by the manufacturer, to the clean, tack-coated concrete deck, to form a uniform film having a minimum thickness of 4 mm and a maximum thickness of 6 mm. The laying operation shall be such that discontinuities in the membrane are avoided and any joints lapped 150 mm. The membrane shall be applied over all waterproofed joints and cracks, and shall extend up the face of curbs, barrier walls, and deck drains, to the height of the top of the hot mix surface course. Deck drains and drainage tubes shall not be plugged.

300.5.15.5.7 Application of Protection Board

The asphalt membrane thickness shall be checked to ensure conformance to the Technical Requirements, prior to placing the protection board. Protection boards shall be laid on the asphalt membrane, while the membrane is still hot, with the length of the board running transversely, on the deck. The protection boards shall be placed with edges overlapping 25 mm both longitudinally and transversely. The protection board edge shall be within 5 mm of all curbs, drain verticals, and deck joint verticals.

Protection boards shall be placed such that the longitudinal (direction of traffic flow) joints are staggered at least 150 mm. It shall be rolled by means of a linoleum or lawn type roller while the membrane is still warm, in order to ensure good contact with the membrane. Holes shall be cut through the protection board to allow water to drain freely through the drainage tubes. In instances where edges of the protection board curl up, the edges shall be cemented down using hot membrane material. Protection boards that are warped, distorted or damaged in any way, by manufacture, storage, handling or exposure to weather, shall be rejected.

300.5.15.6 Sampling and Testing

Sufficient quantities of the asphalt membrane, rubber membrane, and protection board shall be supplied from the materials being used on the Project for immediate analysis, flow tests, water absorption, or for other future testing purposes.

300.5.15.7 List of Approved Materials

300.5.15.7.1 Hot Applied Rubberized Asphalt Membrane

- "Bakor" 790-11
- "Tremproof" 150
- "Permaquick 6100" W.I. 250
- "Hydrotech 6125"
- "Beamalastic 1213 BDM"

300.5.15.7.2 Rubber Membrane

- "Elastosheet 6147"
- ABP47 Elastometric Reinforcement@
- ABakor 990-25"

300.5.15.7.3 Waterproofing Protection Board

Test results and samples of proposed protection board shall be submitted to the Department for review.

Acceptable products of protection board shall consist of spun glass fibres and not cellulose reinforcing fibres. Products which currently meet the 5% or less water absorption requirement are:

- "Vibraflex MTO Protection Board"
- "Bakor Asphalt Protection Board"
- "IKO Protectboard"

300.5.15.8 Paving Equipment and Methods

300.5.15.8.1 General

Equipment and methods used for asphalt concrete pavement on bridge deck waterproofing membranes shall be adequate to produce and place the material as specified.

300.5.15.8.2 Paver

Pavers shall be self-propelled and operated to maintain required levels, cross-falls and joint matching.

300.5.15.8.3 Compaction Equipment

Sufficient self propelled equipment shall be provided to obtain the required degree of compaction of the asphalt concrete mixture. The compaction capability of the equipment used shall equal or exceed the placing rate of the spreading operations and shall be capable of obtaining the required compaction before the temperature of the mat falls below specified levels. Compaction equipment shall be of a suitable size, weight and type, such that displacement of the mat and/or disruption of underlying materials does not occur. Specialized equipment may be required to achieve adequate compaction and smoothness in tight corners, such as adjacent to expansion assemblies and deck joints.

A minimum of two pieces of compaction equipment shall be provided. They shall be rollers of at least 10 tonnes mass, one rubber tired and one smooth steel drum type. Vibrators on vibratory rollers shall not be activated.

The compaction equipment shall be in proper mechanical condition and shall be operated such that uniform and complete compaction is obtained throughout the entire width, depth and length of the pavement being constructed. Rollers provided shall leave a smooth, properly finished surface, true to grade and cross-section without ruts or other irregularities. All compaction equipment shall be equipped with methods of wetting the tires or drums to prevent adhesion or pickup of the asphalt mixture.

300.5.15.9 Placement of Asphalt Concrete Pavement

300.5.15.9.1 Protection of Adjacent Bridge Components

The Contractor must protect curbs, deck joints, and expansion assemblies to prevent splatter or spillage of asphaltic materials.

300.5.15.9.2 Tack Coat

Asphalt tack coat shall be applied to the existing protection board and between lifts of asphalt concrete pavement.

The surface to be tacked shall be dry and free of loose or deleterious material when the tack is applied.

The asphalt tack coat shall be applied in a uniform manner at an application rate of 0.5 ℓ/m^2 and suitable asphalt temperature. Air temperature in the shade at the time of application shall be 5EC or higher.

On areas where traffic is to be accommodated, the tack coat shall be applied in two operations. In the first operation one half of the width shall be tacked with the remaining half being tacked after the first half has cured.

The tack coat shall be protected from traffic or other damage. Areas on which the tack has been damaged by traffic shall be retacked.

300.5.15.9.3 Spreading and Compaction

300.5.15.9.3.1 General

The mixture shall be placed only upon a dry, unfrozen substrate on which the tack coat has cured, and under suitable weather and temperature conditions. Prior to the delivery of the mixture on the work, the base shall be cleaned of all loose or foreign material. The mixture shall be spread and compacted during daylight hours only, unless artificial light is provided.

During spreading and compaction operations, care shall be taken at all times to ensure that:

- Asphalt mixture is not wasted over the side or onto the adjacent surface mat.
- Damage is not done to the waterproofing membrane, curbs, manholes, drains or medians.
- Damage is not done to guide posts, guardrails, signs, power conduits or any other roadside installations.

Immediate and adequate repair shall be made of any damage resulting from construction activities.

300.5.15.9.3.2 Spreading

The mix shall be spread at a temperature sufficient for specified compaction and finishing at the final placement area.

The manner of placing shall ensure safe accommodation of traffic, quality control and drainage. The longitudinal and transverse edges of each lane shall be straight in alignment, uniform, and of the same thickness as the adjoining pavement layer. Adequate measures for the protection of the exposed edges shall be maintained throughout the work.

Each layer shall be placed, finished and compacted for the full width, and then allowed to cool down to 50EC or colder prior to commencing the subsequent layer.

In the placing of successive layers, the individual mixture spreads shall be aligned in a manner such that the longitudinal joints in successive layers do not coincide. Unless otherwise directed, the lateral distance between the longitudinal joints in the successive layers shall be not less than 0.30 m. The longitudinal joint of the final lift of asphalt concrete pavement shall not be located within the wheel path areas.

The surface of all lifts shall not exhibit evidence of segregation, such as pockets of fine and coarse material.

All longitudinal and transverse joints shall be of the vertical butt joint type, made in a careful manner, well bonded and sealed, and shall be finished to provide a continuous, smooth profile across the joints.

300.5.15.9.3.3 Compaction

The compaction process shall be monitored using a Control Strip Method. Control Strips are generally established on each mat placed.

The Control Strip lift shall be compacted using at least the following equipment:

- (a) One steel roller weighing not less than 10 t; and
- (b) One self-propelled pneumatic rollers, ballasted to its maximum capacity, weighing not less than 10 t.

Once the mix has been spread by the paver and the initial pass of the breakdown roller has been done, moisture and density measurements for determining the Control Density will commence at five locations within the Control Strip area, and will continue following repeated passes of the compaction equipment until the apparent maximum density is attained. These measurements will be taken using nuclear testing equipment.

The pavement shall be compacted to a minimum average density of 97% of Marshall Density, with no individual density less than 95%.

When the compaction methods and procedures are not achieving the desired compaction specifications, cores of the top lift pavement shall be taken. The number of cores will be determined by the Department. The cores will be tested by the Contractor and the results provided to the Department as they become available.

Percent compaction will be expressed in percent of Marshall Standard Density. The Marshall Standard Density used for determining pavement compaction shall be as follows:

- (a) Marshall Densities determined on field sampled mix, or if not available then;
- (b) Marshall Design Density as reported in the accepted mix design.

Coring shall be done using methods which will not damage the rubberized asphalt membrane or protection board. Core holes shall be completely de-watered and dried. A generous application of liquid asphalt shall be applied to the bottom and sides of the core hole and allowed to cure. Asphalt mix shall then be tamped in lifts into the core hole until flush with the surface of the surrounding pavement.

Coring shall not be undertaken without the approval of the Department.

In order to maintain the crown of the bridge deck and approaches, the Contractor shall avoid operating the compaction equipment on or across the crown. Compaction procedures and equipment shall be such that displacement of the mixture does not occur. Roller wheels shall be kept slightly moistened by water or oil to prevent picking up the mixture, but an excess of either water or oil will not be permitted.

In cases where the asphaltic mixture is placed under weather and temperature conditions which may be considered less than ideal, normal operations shall be modified to provide special attention to these situations such that specified compaction results are achieved.

300.5.15.9.3.4 Hot-Applied Rubberized Membrane Waterproofing

The first layer of the ACP Wearing Surface shall be spread by the asphalt paver moving with the laps in the protection board.

With the possibility of damage to the waterproofing membrane, the paver must not push the delivery trucks and all equipment must perform all turning movements off the bridge deck. Dumping of the asphalt mixture onto the protection board ahead of the paver will not be permitted.

The prepared material shall be placed and compacted in two nominal 40 mm layers.

To avoid displacement of the mixture the first lift shall be compacted only after the spread asphalt mixture has cooled to 105EC. The second lift shall be compacted when the spread asphalt mixture is within the following temperature ranges:

ASPHALT GRADE	COMPACTION TEMPERATURE RANGE	
	FIRST LIFT	SECOND LIFT
150 - 200 (A)	MAX. 105EC	128EC - 138EC
200 - 300 (A)	MAX. 105EC	123EC - 133EC

Due to the cooler compaction temperature (105EC) of the first lift, it may not be possible to achieve the 97 percent average density.

GENERAL NOTES
 1. ALL DIMENSIONS SHALL CONFORM TO THE REQUIREMENTS OF SECTION 14, BRIDGE DECK WATERPROOFING OF THE SPECIFICATIONS FOR BRIDGE CONSTRUCTION.

LEGEND
 80mm TWO-COURSE HOT-MIX ASPHALTIC CONCRETE PAVEMENT.
 3.2mm PROTECTION BOARD, OVERLAP PICES 120mm MIN. (SEE SECTION 14 FOR DETAILS OF JOINTS OF WICK DRAIN AND CONCRETE PAVING LIP EDGES).
 2mm ASPHALT MEMBRANE.
 1.2 mm RUBBER MEMBRANE CENTRED OVER CONSTRUCTION JOINTS & GROUDES OR POTENTIAL CRACKS. (SEE SECTION 14 FOR DETAILS OF JOINTS AND GROUDES).
 OVERLAP VERTICAL EXTENSION AT CORNERS AND OVERLAP HORIZONTAL EXTENSION AT CORNERS. APPLY RUBBER MEMBRANE WITH PASTE STREPS AND JOINTS. RUBBER MEMBRANE SHALL BE APPLIED TO BOTH SIDES OF THE JOINTS.
 2) WFT HOOK PROTECTS
 WICK DRAIN - WELY.M7/807 OR APPROVED EQUIVALENT (INSTALL WHEN MEMBRANE IS TACKY).

DECK BULB TEE GIRDER BRIDGES

DECK BULB TEE GIRDER BRIDGES WITH FIELD CAST CONCRETE DECK

SCC COMPOSITE BRIDGES

BULB TEE GIRDER BRIDGES WITH FIELD CAST CONCRETE DECK

MEDIAN ON DECK
 SEE SITE SPECIFIC DRAWING FOR CRACK DRAINS WHERE SPECIFIED.
 DECK WATERPROOFING TO BE APPLIED IN TWO LIFTS TO WATERPROOFING WITHOUT PROTECTION BOARD. MEDIAN CONCRETE SHALL BE CURED FOR COMPLETELY 7 DAYS PRIOR TO PLACING THE ROADWAY PORTION OF WATERPROOFING.

CAST-IN-PLACE GIRDER BRIDGES WITH FIELD CAST CONCRETE DECK

CAST-IN-PLACE PIER DIAPHRAGMS PRECAST GIRDERS

STEEL OR CONCRETE GIRDER BRIDGES WITH FIELD CAST DECK

CAST-IN-PLACE DECK CONSTRUCTION JOINTS

DETAILS AT BRIDGE ENDS WITH APPROACH SLABS

DETAILS AT BRIDGE ENDS WITHOUT APPROACH SLABS

EDGE DETAIL AND PVC DRAIN PIPE

DECK SIDE
ABUT SIDE
DETAILS AT DECK JOINTS

APPROVALS
 APPROVED BY: ALAN WAIN
 TECHNICAL MANAGER
 TECHNICAL STANDARDS BRANCH
 DATE: JANUARY 12, 2022

REVISIONS: 1, 2, 3, 4, 5, 6, 7, 8, 9, 10, 11, 12, 13, 14, 15, 16, 17, 18, 19, 20, 21, 22, 23, 24, 25, 26, 27, 28, 29, 30, 31, 32, 33, 34, 35, 36, 37, 38, 39, 40, 41, 42, 43, 44, 45, 46, 47, 48, 49, 50, 51, 52, 53, 54, 55, 56, 57, 58, 59, 60, 61, 62, 63, 64, 65, 66, 67, 68, 69, 70, 71, 72, 73, 74, 75, 76, 77, 78, 79, 80, 81, 82, 83, 84, 85, 86, 87, 88, 89, 90, 91, 92, 93, 94, 95, 96, 97, 98, 99, 100, 101, 102, 103, 104, 105, 106, 107, 108, 109, 110, 111, 112, 113, 114, 115, 116, 117, 118, 119, 120, 121, 122, 123, 124, 125, 126, 127, 128, 129, 130, 131, 132, 133, 134, 135, 136, 137, 138, 139, 140, 141, 142, 143, 144, 145, 146, 147, 148, 149, 150, 151, 152, 153, 154, 155, 156, 157, 158, 159, 160, 161, 162, 163, 164, 165, 166, 167, 168, 169, 170, 171, 172, 173, 174, 175, 176, 177, 178, 179, 180, 181, 182, 183, 184, 185, 186, 187, 188, 189, 190, 191, 192, 193, 194, 195, 196, 197, 198, 199, 200, 201, 202, 203, 204, 205, 206, 207, 208, 209, 210, 211, 212, 213, 214, 215, 216, 217, 218, 219, 220, 221, 222, 223, 224, 225, 226, 227, 228, 229, 230, 231, 232, 233, 234, 235, 236, 237, 238, 239, 240, 241, 242, 243, 244, 245, 246, 247, 248, 249, 250, 251, 252, 253, 254, 255, 256, 257, 258, 259, 260, 261, 262, 263, 264, 265, 266, 267, 268, 269, 270, 271, 272, 273, 274, 275, 276, 277, 278, 279, 280, 281, 282, 283, 284, 285, 286, 287, 288, 289, 290, 291, 292, 293, 294, 295, 296, 297, 298, 299, 300, 301, 302, 303, 304, 305, 306, 307, 308, 309, 310, 311, 312, 313, 314, 315, 316, 317, 318, 319, 320, 321, 322, 323, 324, 325, 326, 327, 328, 329, 330, 331, 332, 333, 334, 335, 336, 337, 338, 339, 340, 341, 342, 343, 344, 345, 346, 347, 348, 349, 350, 351, 352, 353, 354, 355, 356, 357, 358, 359, 360, 361, 362, 363, 364, 365, 366, 367, 368, 369, 370, 371, 372, 373, 374, 375, 376, 377, 378, 379, 380, 381, 382, 383, 384, 385, 386, 387, 388, 389, 390, 391, 392, 393, 394, 395, 396, 397, 398, 399, 400, 401, 402, 403, 404, 405, 406, 407, 408, 409, 410, 411, 412, 413, 414, 415, 416, 417, 418, 419, 420, 421, 422, 423, 424, 425, 426, 427, 428, 429, 430, 431, 432, 433, 434, 435, 436, 437, 438, 439, 440, 441, 442, 443, 444, 445, 446, 447, 448, 449, 450, 451, 452, 453, 454, 455, 456, 457, 458, 459, 460, 461, 462, 463, 464, 465, 466, 467, 468, 469, 470, 471, 472, 473, 474, 475, 476, 477, 478, 479, 480, 481, 482, 483, 484, 485, 486, 487, 488, 489, 490, 491, 492, 493, 494, 495, 496, 497, 498, 499, 500, 501, 502, 503, 504, 505, 506, 507, 508, 509, 510, 511, 512, 513, 514, 515, 516, 517, 518, 519, 520, 521, 522, 523, 524, 525, 526, 527, 528, 529, 530, 531, 532, 533, 534, 535, 536, 537, 538, 539, 540, 541, 542, 543, 544, 545, 546, 547, 548, 549, 550, 551, 552, 553, 554, 555, 556, 557, 558, 559, 560, 561, 562, 563, 564, 565, 566, 567, 568, 569, 570, 571, 572, 573, 574, 575, 576, 577, 578, 579, 580, 581, 582, 583, 584, 585, 586, 587, 588, 589, 590, 591, 592, 593, 594, 595, 596, 597, 598, 599, 600, 601, 602, 603, 604, 605, 606, 607, 608, 609, 610, 611, 612, 613, 614, 615, 616, 617, 618, 619, 620, 621, 622, 623, 624, 625, 626, 627, 628, 629, 630, 631, 632, 633, 634, 635, 636, 637, 638, 639, 640, 641, 642, 643, 644, 645, 646, 647, 648, 649, 650, 651, 652, 653, 654, 655, 656, 657, 658, 659, 660, 661, 662, 663, 664, 665, 666, 667, 668, 669, 670, 671, 672, 673, 674, 675, 676, 677, 678, 679, 680, 681, 682, 683, 684, 685, 686, 687, 688, 689, 690, 691, 692, 693, 694, 695, 696, 697, 698, 699, 700, 701, 702, 703, 704, 705, 706, 707, 708, 709, 710, 711, 712, 713, 714, 715, 716, 717, 718, 719, 720, 721, 722, 723, 724, 725, 726, 727, 728, 729, 730, 731, 732, 733, 734, 735, 736, 737, 738, 739, 740, 741, 742, 743, 744, 745, 746, 747, 748, 749, 750, 751, 752, 753, 754, 755, 756, 757, 758, 759, 760, 761, 762, 763, 764, 765, 766, 767, 768, 769, 770, 771, 772, 773, 774, 775, 776, 777, 778, 779, 780, 781, 782, 783, 784, 785, 786, 787, 788, 789, 790, 791, 792, 793, 794, 795, 796, 797, 798, 799, 800, 801, 802, 803, 804, 805, 806, 807, 808, 809, 810, 811, 812, 813, 814, 815, 816, 817, 818, 819, 820, 821, 822, 823, 824, 825, 826, 827, 828, 829, 830, 831, 832, 833, 834, 835, 836, 837, 838, 839, 840, 841, 842, 843, 844, 845, 846, 847, 848, 849, 850, 851, 852, 853, 854, 855, 856, 857, 858, 859, 860, 861, 862, 863, 864, 865, 866, 867, 868, 869, 870, 871, 872, 873, 874, 875, 876, 877, 878, 879, 880, 881, 882, 883, 884, 885, 886, 887, 888, 889, 890, 891, 892, 893, 894, 895, 896, 897, 898, 899, 900, 901, 902, 903, 904, 905, 906, 907, 908, 909, 910, 911, 912, 913, 914, 915, 916, 917, 918, 919, 920, 921, 922, 923, 924, 925, 926, 927, 928, 929, 930, 931, 932, 933, 934, 935, 936, 937, 938, 939, 940, 941, 942, 943, 944, 945, 946, 947, 948, 949, 950, 951, 952, 953, 954, 955, 956, 957, 958, 959, 960, 961, 962, 963, 964, 965, 966, 967, 968, 969, 970, 971, 972, 973, 974, 975, 976, 977, 978, 979, 980, 981, 982, 983, 984, 985, 986, 987, 988, 989, 990, 991, 992, 993, 994, 995, 996, 997, 998, 999, 1000.

400.0 OPERATIONS - NEW INFRASTRUCTURE

400.1 OPERATIONS - GENERAL

This Section 400.0 covers the operations, maintenance and rehabilitation requirements applicable to roadways and bridge structures in the New Infrastructure.

400.1.1 RESPONSIBILITY FOR OPERATIONS

The Contractor is responsible for the supply of all management, supervision, professional and technical services, quality control and assurance, labour, materials, utilities and equipment for performing all of the duties and obligations to operate, maintain and rehabilitate the New Infrastructure during the Operating Period.

These responsibilities include the supply and payment for electrical power for roadway lighting and signalization, and any other utilities required for the New Infrastructure. The Contractor is responsible for safe and efficient site traffic accommodation during the Operating Period.

The operational and performance requirements described in the Technical Requirements represent the requirements that shall be met throughout the Operating Period. The Contractor shall measure roadway and bridge structure conditions and assure compliance to the operational and performance requirements throughout the Operating Period. Where specific operational and performance requirements are not given, the Contractor is expected to operate and maintain roadway elements and bridge structures to a standard of safety, effectiveness and operation equal to, or better than, what is currently being provided on other roadway systems of similar age and type on the Provincial highway system.

Reduction of or restrictions to allowable legal load(s), during spring time thawing conditions or at any other time, is not permitted for any roadway within the New Infrastructure, during the Operating Period.

400.1.2 MAINTENANCE AND REHABILITATION REQUIREMENTS

The requirements to be met in the maintenance and rehabilitation of the New Infrastructure during the Operating Period shall conform to the requirements for design and construction of the New Infrastructure, as well as those of the Contractor's Operations and Maintenance Plan and the Contractor's Infrastructure Wholelife Management Plan (such Plans forming part of Schedule 4 (Contractor's Management Systems and Plans) to the DBFO Agreement).

As-Built Construction Reports shall be updated, as required, to reflect maintenance and rehabilitation activities that change the physical dimensions or characteristics of the Infrastructure. The maximum time for completion and the providing of the updated As-

Built Construction Reports to the Department shall be two months after completion of the maintenance or rehabilitation activity. If the updated As-Built Construction Reports are not available to the Department within the specified time, a Payment Adjustment of \$2,000/month or any partial month, for every month in excess of the specified time shall apply until available.

The Contractor is responsible for reclaiming all areas of the Road Right of Way and/or stormwater management facilities that have been disturbed during the Operating Period and shall obtain any required Reclamation Certificates related to these activities within 12 months of completing the reclamation activity.

400.1.3 COMPLIANCE WITH PERFORMANCE REQUIREMENTS

During the Operating Period, the New Infrastructure shall be maintained in conformance with any allowable tolerances as specified for individual performance requirements, subject to the following:

- If measurements indicate that the New Infrastructure no longer complies with the performance requirements but falls within the permitted tolerance(s), the Contractor will have the option of correcting the New Infrastructure such that it conforms to the performance requirements or foregoing the repairs and paying Payment Adjustments. The option of foregoing repairs shall not be allowed at the handback of the New Infrastructure to the Department at the end of the Term.
- If measurements indicate that the New Infrastructure no longer complies with the performance requirements and also exceeds any allowable tolerances, the Contractor shall repair the New Infrastructure so that it conforms to the performance requirements.

For performance requirements that do not include an allowable tolerance, the Contractor shall complete such work as required to achieve full compliance to the performance requirements.

In addition to the Contractor's regular inspection and measurements, the Department may undertake reviews and measurements of the New Infrastructure at any time and will advise the Contractor of non-compliance.

Where Payment Adjustments are described relative to a kilometre section of the roadway, the kilometre will be a continuous section of a single lane. Neither the requirement nor the Payment Adjustments will be pro-rated based on a partial kilometre length, but will be calculated for the next highest full kilometre length. Crossroads and individual ramps or loops will be considered as discrete sections and treated as one kilometre regardless of the actual length. Where Payment Adjustments are described relative to a period of time or a portion thereof, the Payment Adjustment shall not be prorated but shall be applied in full even if only a portion of the specified period of time has elapsed.

400.1.3.1 Alternative Inspection and Testing Methods

During the Operating Period, new technological developments may result in alternative inspection and testing methods and techniques that are more accurate, effective or economical. Mutually agreeable alternative inspection and testing methods and techniques may be introduced during the Operating Period. These new testing methods and techniques may also require new mutually agreeable performance requirements that are consistent with the intent of existing performance requirements.

400.1.4 APPEAL OF DEPARTMENT MEASUREMENTS

In any case where Department measurements have concluded that a deficiency exists, the Contractor may appeal within 30 days, the results of any measurement. Measurements made by the Contractor, using methods and equipment of equal or better accuracy to the Department's specified methods, which indicate the appealed component is not deficient, will be the only cause accepted for allowing an appeal.

The Department and the Contractor will mutually select an independent third party to undertake the appeal measurement(s).

The appeal measurements will be arranged for and paid by the Department and the new measurements shall be binding on the Contractor and the Department and shall not be subject to the Dispute Resolution Procedure. Notwithstanding the foregoing, the Department may, at its sole discretion, elect to accept the measurements submitted by the Contractor as cause for the appeal and forego further measurements.

If the independent third party's measurements verify the deficiency, the Contractor shall be invoiced by the Department, and shall reimburse the Department, for the third party appeal measurement costs plus an additional \$3,500 per appeal.

Any Payment Adjustments supported by the independent third party's measurements shall be upheld. If the independent third party's measurement(s) verify that no deficiency exists, such Payment Adjustments shall be reversed.

400.1.5 IMMINENT DANGER REPAIRS

In instances where the Contractor and/or the Department determines an Imminent Danger (as defined below) exists on the New Infrastructure, the Contractor shall have representation within the Road Right of Way, on route to the Imminent Danger, within 30 minutes of becoming aware of, or of the time the Contractor should have been aware of, the Imminent Danger and shall immediately initiate action to protect traffic and the public from the Imminent Danger and shall continue the action until the Imminent

Danger is eliminated. This action may take the form of a temporary solution, including the closing of traffic lanes, until permanent repairs are able to be undertaken or the Imminent Danger is removed. If protective action is not undertaken or traffic is not protected from the Imminent Danger immediately, the Department may elect to undertake such action as it determines necessary and the Contractor shall be responsible for the actual cost of the actions which may include the cost of accommodating traffic over, through or around portions of the Infrastructure, if necessary, plus a 25% administration fee. These costs shall be deducted from Payments to be made to the Contractor. In instances where the Contractor fails to meet the above timelines and/or the Department is forced to undertake action to protect any user from an Imminent Danger, the Contractor shall also be assessed a Payment Adjustment of \$10,000/occurrence. The third occurrence in any consecutive 12 month period anywhere on the Infrastructure shall be a potential Termination Event for the purposes of and having the consequences set out in Section 16.8(k) of the DBFO Agreement. The Department shall provide the Contractor with timely notice after the Department has considered it necessary to take action to protect a user from an Imminent Danger situation. The responsibility for the repair of the cause of the Imminent Danger shall be governed by the DBFO Agreement and the other applicable provisions of the Technical Requirements.

For the purposes of this section, “Imminent Danger” refers to a safety hazard that may be encountered by any user of the Infrastructure due to an accident, condition or any other abnormal occurrence on the Infrastructure.

400.1.6 LANE CLOSURE

Under no circumstance, except for an Excepted Lane Closure (as defined below), shall the Contractor close all lanes in either direction during the Operating Period nor implement measures to require or to seek to encourage the public to use an alternative route away from the Infrastructure.

If as a result of an Excepted Lane Closure the need arises to use signs or other measures to require the public to use an alternative route away from the Infrastructure, the Contractor may effect such measures, provided that the Contractor shall as soon as reasonably practicable advise the Department of such measures and the reasons therefore. The Contractor shall take all reasonable steps to minimize the duration of such measures.

Within 60 days after Construction Completion, the Contractor shall submit to the Department in accordance with the Review Procedure as set out in Schedule 5 (Design and Plan Certification and Review Procedure) to the DBFO Agreement (the “Review Procedure”), a schedule for Lane Closures (as defined below) in respect of the Infrastructure for the first 12 month period after Traffic Availability (the “Agreement Year”) and the next succeeding Agreement Year. No later than January 1 in each Agreement Year after the first Agreement Year the Contractor shall submit to the Department in accordance with the Review Procedure a schedule for Lane Closures in respect of the Infrastructure for the next succeeding Agreement Year. Each schedule of

Lane Closures (the “Schedule of Lane Closures”) shall give details of the proposed lanes of Lane Closure, start and end dates for each period of Lane Closure, and the work to be carried out.

The Contractor shall inform the Department of any changes to a Schedule of Lane Closures no later than 60 days prior to the commencement of the applicable Lane Closure.

The Department may raise comments in respect of any period of Lane Closure requested in a Schedule of Lane Closures. In such event, the Department shall notify the Contractor thereof with reasons and shall indicate, in the case of an objection, an appropriate duration for such Lane Closure and in any other case a period when the unacceptable period can be re-scheduled, on the basis that each such re-scheduled period shall be as close as reasonably practicable to the requested period of Lane Closure and of equal duration or, if the Contractor has indicated another period and/or duration that would be preferable to it and that is acceptable to the Department, such other period and/or duration. The Contractor shall thereupon amend the applicable Schedule of Lane Closures accordingly and re-submit the same to the Department in accordance with the Review Procedure.

The Department's approval of Lane Closures shall not be unreasonably withheld or delayed, having regard to the factors set out in the Review Procedure.

The Contractor shall not affect any Lane Closures save:

- in accordance with the Schedule of Lane Closures to which no objection has been made under the Review Procedure; or
- in an Excepted Lane Closure.

Notwithstanding that there has been no objection to the Schedule of Lane Closures in accordance with the Review Procedure, the Department may upon 60 days prior written notice require the Contractor to re-schedule a period of Lane Closure if due to a change in circumstances such re-scheduling is necessary.

The Department may not require:

- that such period of Lane Closure be brought forward by more than 60 days from the scheduled date of commencement of such period; or
- that a period of Lane Closure be deferred by more than 60 days from the scheduled date of commencement.

If as a result of an Excepted Lane Closure, the need arises for unscheduled maintenance or repair work requiring Lane Closures, the Contractor shall effect such Lane Closures provided that the Contractor shall as soon as reasonably practicable advise the Department of such closure and the reasons therefore and shall take all reasonable steps to minimize the duration of such Lane Closure.

All Lane Closures shall be subject to the Lane Closure Payment Adjustments except Lane Closures (the “Excepted Lane Closure”) arising, and without being caused by the negligence of the Contractor or those for whom the Contractor is responsible at law, from:

- an emergency, including without limitation clean-up of a motor vehicle accident;
- an order of the police;
- Approved Special Events as defined in Section 200.3.9.2 (Special Events – Partial or Full Closure Events);
- Severe Storm Events (as defined in Section 400.3.1 (Winter Maintenance Operation Requirements – General));
- Repairs to the New Infrastructure caused by the Province, its agents and employees and by third party damage provided all reasonable steps are being taken to complete the repairs in accordance with the Contractor’s obligations; or
- a direction of the Department or the performing of the Province’s obligations under the DBFO Agreement.

The Contractor shall provide to the Department such information (including without limitation details of proposed Lane Closures and information about its traffic safety and management measures on the Infrastructure) as may be required for purposes of any information service operated by or on behalf of the Department from time to time.

The Contractor shall operate during the Operating Period a telephone service answered by a knowledgeable person of the Contractor to respond to questions from the public in relation to the Infrastructure.

Subject to the Excepted Lane Closures, for every full or partial hour of Lane Closure (as defined below) occurrence anywhere on the Infrastructure, during the Operating Period, the Contractor shall be assessed a Payment Adjustment at the applicable lane closure rate. The length of the Lane Closure for determination of Lane Closure Payment Adjustments shall be rounded up to the next higher whole kilometre.

For planned maintenance and rehabilitation activities on two-lane roadways or bridge structures, the Contractor must have at least one lane open to traffic at all times.

For planned maintenance and rehabilitation activities on multi-lane roadways and bridge structures, the Contractor must have at least one lane open to traffic, in each direction, at all times.

Lane Closure Payment Adjustments are as follows:

Type	Timing/Duration	Rate
Peak Hours* - Weekdays	0600 to 0900 and 1530 to 1800 hrs	\$400/hr/lane-km
Day – Weekdays	0900 to 1530 hrs	\$150/hr/lane-km

Day - Weekends and Statutory Holidays	0600 to 1800 hrs	\$150/hr/lane-km
Evening	1800 to 2200 hrs	\$100/hr/lane-km
Night	2200 to 0600 hrs	No Charge

* A Lane Closure for planned operational purposes may not be started during Peak Hours.

A Lane Closure is defined as:

- Any partial or complete closure of a traffic lane; or
- Any reduction of posted speed to less than 75% of the normal posted speed prior to construction impacting any through lane, merge lane or ramp, collector-distributor (C-D) road, turn lane, crossroad, bridge structure, detour or other road forming a part of or connected to the Infrastructure.

Conclusion of Lane Closure is defined as:

- Continuous, smooth, paved intact travel surface;
- Traffic control removed and traffic fully restored; and
- Cause of closure has been removed and all safety requirements have been satisfied.

Also reference Section 400.5.1.3.7 (Traffic Accommodation).

400.1.7 IN-SERVICE SAFETY REVIEW

On an as-needed basis, the Department will compare the reported collision rates on roadway segments and interchanges on the New Infrastructure to rates recorded on similar segments of divided highways and interchanges in Alberta.

If the collision rate on any roadway segment or interchange on the New Infrastructure exceeds the benchmark by 10% or more, the Department may elect to conduct an In-Service Safety Review. If so elected, the review will be undertaken within three months of notification of the need for such a review. The In-Service Road Safety Review shall be undertaken following the Transportation Association of Canada’s current guidelines.

The Department will provide a copy of the In-Service Safety Review to the Contractor. The Contractor shall implement any minor operational recommendations at its cost within six months of the completion of the review. The minor operational recommendations shall include the following:

- Provision and installation of delineators;
- Revised snow clearing and ice control procedures;

- Bridge deck icing plan procedures;
- Revised pavement markings;
- Revised directional, regulatory and warning signing (does not include sign structures);
- Revised traffic signal timings; and
- Guardrail adjustment or installation of new guardrail.

If the minor operational recommendations from the In-Service Safety Review are not implemented within the specified time by the Contractor, a Payment Adjustment of \$1,000/week or any partial week, for the first four weeks and \$2,000/week or any partial week, thereafter shall apply until all of the minor operational recommendations are implemented.

400.2 INSPECTION, EMERGENCY AND ROUTINE MAINTENANCE REQUIREMENTS

400.2.1 ROADWAY INSPECTIONS REQUIREMENTS

The Contractor's Operation and Maintenance Plan (Section 100.2.9) shall include details on how roadway inspections will be carried out and shall as a minimum, meet the following requirements:

- Inspect the roadway at a minimum frequency of every two hours between 6:30 a.m. and 6:30 p.m., Monday to Friday with the exception of non-Business Days, and every four hours between 6:30 p.m. and 6:30 a.m., Monday to Friday with the exception of non-Business Days;
- Inspect the roadway a minimum of once every four hours (24 hours per day) on days other than Business Days;
- Observe road conditions, repair requirements, snow or weather issues, icing conditions on bridge decks, and sign conditions for each inspection; and
- Confirm the retroreflectivity of signs visually during dark (night time conditions) at least once every two months. Signs that are reasonably considered to be deficient shall be tested within 30 days of the visual inspection.

The Contractor shall provide sufficient resources to patrol the roadway, to observe, react to and report all circumstances or conditions affecting the travelling public or the future repair of the roadway or appurtenances. The Contractor shall investigate reports of adverse conditions from members of the public, regulatory agencies, police authorities or the Department, and perform the immediate repair of all hazardous conditions in accordance with Section 400.1.5 (Imminent Danger) and Section 400.2.2 (Emergency Maintenance).

400.2.1.1 Routine Observations

During the performance of roadway inspections, emergency maintenance, routine maintenance or at any other time the Contractor's personnel are travelling on the roadway, such personnel shall observe conditions of the roadway surface, appurtenances, and the Road Right of Way for the purpose of identifying any deficiencies and scheduling such work as required to maintain compliance to the Technical Requirements.

Items of work which would typically be identified during routine observations include but are not limited to the following:

- Damaged signs;

- Drainage problems including blockages, erosion or lack of capacity of ditches, culverts and drainage grates, particularly during spring thaw and run-off. The Contractor shall make interim repairs in these areas when possible;
- Any required cleaning, litter removal or snow removal;
- Damage to structures or appurtenances;
- Roadside or median barriers which have been damaged or moved from the original position, or any other condition that prevents, or reduces the effectiveness of the barrier from performing its intended function;
- Graffiti;
- Burned out lights on the roadway lighting systems;
- Non-functioning, malfunctioning or burned out lights on traffic control lighting systems; and
- Condition of bridge structure components, e.g. bridge rail, bridge deck and bridge deck joints.

400.2.1.2 Daily Road Reports

As part of normal winter duties or as otherwise required, the Contractor shall provide daily road reports in the Department's standard format to the Alberta Motor Association by 0600 hours. These reports shall detail driving conditions on the New Infrastructure and shall be updated as required, so that the travelling public is kept current with changing roadway or weather conditions. The Contractor shall provide the Department with a copy of all reports issued.

400.2.2 EMERGENCY MAINTENANCE

Any work identified which falls under the category of emergency maintenance or otherwise results in an unsafe condition shall be immediately addressed by the Contractor and, subject to the DBFO Agreement and the other applicable provisions of the Technical Requirements, at the Contractor's cost.

Emergency maintenance activities, requiring the Contractor's immediate response by having representation within the Road Right of Way, on route to the emergency, within 30 minutes of becoming aware of, or of the time the Contractor should have become aware of, include but are not limited to, the following:

- Repairing or replacing critical regulatory signs (STOP and YIELD) or performing temporary repairs of signs;
- Removing from the roadway surface, roadkill and debris of a size or type that may create a hazard;
- Report all incidences of roadkill to the appropriate authorities;
- If an animal is injured, the Contractor shall contact the police and/or fish and wildlife officials, who will determine and arrange for the action required;

- In cases involving livestock, the Contractor shall remove the carcass from the roadway surface and contact the owner of the animal to dispose of the carcass. If the owner cannot be contacted, the Contractor shall remove the carcass from the Road Right of Way, dispose of the carcass at an approved site and immediately notify the Department;
- Repairing traffic signals and advanced warning devices, including without limitation:
 - Resetting signals if the lights are in flash mode;
 - Replacing burned-out bulbs; or
 - When the lights are completely out of service, setting up portable STOP signs from all directions until permanent repairs occur;
- Responding to accidents or natural disasters, including without limitation:
 - Traffic control, including erecting detours or barricades in accordance with appropriate traffic control requirements;
 - Supply and erection of emergency signs;
 - Cleaning-up accident or disaster site;
 - Removing from the roadway surface, any material including damaged guardrail which presents a hazard to the travelling public;
 - Applying absorbent material to minor spills at accidents;
 - Placing “Police Emergency Ahead” signs at the scene of collisions, spills or obstructions on the roadway;
 - Providing emergency traffic control and arrowboards;
 - Reopening of the roadway within one hour of cleaning the accident or natural disaster; and
 - Communication with, coordinating with, and providing access for, emergency response services that may be required on the Infrastructure or be required to pass over the Infrastructure;
- Notification of and cooperation with the relevant emergency and/or regulatory authorities in the containment and clean-up of all spills, including those in ditches and ponds;
- Providing adequate marking of any conditions on the roadway surface or in the Road Right of Way which are a hazard to the travelling public, including:
 - Emergency repair and marking of unsafe or poor pavement conditions; and
 - Emergency repair and/or marking of unsafe or poor bridge structure conditions.

400.2.3 ROUTINE MAINTENANCE

The Contractor’s routine maintenance activities shall include, but not be limited to, the following:

- Removing and disposing of incidental refuse and litter from within the Road Right of Way;
- Straightening or reinstalling sign posts;
- Shimming and tightening connections on breakaway sign posts as required;

- Straightening or reinstalling delineator posts and replacing reflective strips on guardrails and delineator posts;
- “Summerize” signals and control boxes;
- “Winterizing” signals and control boxes;
- Washing signs, delineators and reflective strips on guardrail. If soap is used, it must be biodegradable;
- Removing graffiti from all sites;
- Removing non-conforming signs from within the Road Right of Way;
- Performing annual inspections of all drainage system components, scheduling required maintenance and draining, and completing such maintenance and draining prior to freeze-up each year;
- Removing minor blockages in the drainage system on a regular basis; and
- Removing, collecting and disposing of winter sand, tracked dirt and all other debris from the roadway.

400.2.4 MEASURING FOR COMPLIANCE

For all roadway inspection, emergency maintenance and routine maintenance requirements, the Contractor shall undertake the work within the time periods stipulated and in accordance with the Contractor’s Operations and Maintenance Plan (Section 100.2.9).

400.2.5 PAYMENT ADJUSTMENTS

If the roadway inspection, emergency maintenance and routine maintenance are not completed within the required time period on the Infrastructure, the Contractor shall be assessed the following Payment Adjustments.

In this section, “occurrence” refers to an occurrence anywhere on the Infrastructure.

If the Contractor fails to undertake the roadway inspections, Payment Adjustments shall be made as follows. The number of occurrences of non-conformance shall be determined for a consecutive 12 month period.

- \$2,000 for the first occurrence;
- \$4,000 for the second occurrence;
- \$8,000 for the third occurrence; and
- \$16,000 for the fourth occurrence and each occurrence thereafter.

If the Contractor fails to undertake routine maintenance in any consecutive 12 month period, Payment Adjustments shall be made as follows:

- \$4,000 for the first occurrence;

- \$8,000 for the second occurrence;
- \$16,000 for the third occurrence, and each occurrence thereafter.

If the Contractor fails to undertake emergency maintenance in any consecutive 12 month period, Payment Adjustments shall be made as follows:

- \$16,000 for the first occurrence;
- \$32,000 for the second occurrence; and
- The third occurrence shall be a potential Termination Event for the purposes of and having the consequences set out in Section 16.8(k) of the DBFO Agreement.

The Department shall notify the Contractor after the first and second occurrence of non-compliance with an emergency maintenance performance requirement in any consecutive 12 month period.

400.2.6 REPORTING PROCEDURES

All actions taken related to Section 400.2.2 (Emergency Maintenance), shall be reported immediately to the Department.

The Contractor shall record conditions identified during roadway inspections, and any work performed as a result of the observations. Such information shall be reported to the Department. The report shall make a distinction between conditions that required immediate response and those that could be scheduled as future work.

The Contractor shall record and report monthly, all routine maintenance performed, including segments worked and activities performed.

These reports shall include:

- Segment(s) worked; and
- Action(s) taken.

400.3 WINTER MAINTENANCE OPERATION REQUIREMENTS

400.3.1 GENERAL

When undertaking winter maintenance operations, the Contractor shall coordinate its operations to achieve Bare Pavement (as defined below) conditions on all driving lanes and pathways or walkways. “Bare Pavement” is defined as the travel lanes, and walkway/pathways being free of snow, packed snow, frost or ice. Gore areas may have accumulations of loose snow up to 100 mm and shoulders may have accumulations of loose snow up to 30 mm. Drainage points shall be kept free of snow and debris.

All roadways within the New Infrastructure shall have a class assigned to each segment, as described in the following table, on the basis of AADT for that segment. The AADT for all segments shall be determined in accordance with Section 200.3.1 (Traffic Volume Payment Adjustments).

Winter snow clearing and ice control traffic segments may change in length or class depending on the changes in traffic volume (AADT), throughout the Operating Period.

The following table defines the requirements for snow clearing and ice control for the New Infrastructure.

Should winter snow and ice conditions dictate, the “Max. Time to Bare Pavement” requirement may be waived by the Department if the temperature after the “Max. Time to Bare Pavement” is below the indicated value in the last column of the following table. During this time of cold temperatures, the Contractor shall apply winter abrasive material and attempt to physically remove ice and packed snow from the roadway surface. At all times, abrasives will be present on all slippery surfaces within the driving lanes, to ensure safety for the travelling public.

Once the temperature rises above the indicated value in the last column of the following table, the “Max. Time to Bare Pavement” requirement shall recommence, and the Contractor will have the full time to achieve Bare Pavement.

A “Severe Storm Event” is defined as:

- a. A combination of heavy snowfall over a short duration, accumulation of more than 2 cm/hr, or snowfall greater than five days duration, wetter snow, and high winds that results in visibility conditions such that snowplow operations become hazardous and such operations should reasonably cease for several hours;
- b. A wind event where the wind is greater than 60 kph for four consecutive hours; or

- c. A freezing rain or hail event where the accumulation on fixed objects is greater than 6 mm.

Winter Maintenance Standards							
Class	AADT Range	Max. Time to React (hrs)	Max. Time to Bare Pavement (hrs)	Clean Up (hrs)	Severe Storm Event		Max. Time to Bare Pavement Temperature Waiver (°C)
					Max. Time to Bare Pavement (hrs)	Clean Up (hrs)	
A	0 to 30 000	1.5	5	48	10	120	-10
AA	30 001 to 75 000	1.0	3	48	6	120	-15
AAA	75 001 to 125 000	0.5	2	24	4	96	-20
AAAA	125 001 and above	0.5	2	24	4	72	-30

Pathways and walkways shall be cleaned of snow within 48 hours of the end of the Storm Event (as defined below).

The reaction time shall be measured from the time that the Contractor is made aware or notified, or becomes aware or should have been aware of, the need to mobilize equipment, to the time the Contractor starts to engage in snow/ice removal activities with the appropriate equipment. The Contractor shall have engaged snow/ice control activities prior to an accumulation of 15 mm of loose snow. The Contractor may be made aware by its own forces, by the Department, Local Authorities or by police authorities.

The time to Bare Pavement shall be measured from the end of the Storm Event. “Storm Event” shall be defined as a period of time of continuous precipitation and/or condensation and/or wind causing the formation of snow and/or ice on the roadway surface. The end of a storm event shall be considered the last known time of precipitation, heavy snow drifting or condensation affecting the roadway.

Clean-up shall be undertaken after the Storm Event. Banks or drifts of snow greater than 0.5 m shall be removed to at least 2 m from all high speed (posted 100 km/hr or greater) driving surfaces. Intersection sight distance shall be restored on all ramps, intersections and crossroads. Time to complete clean-up is measured from the time precipitation or heavy snow drifting has stopped to the time all clean-up activities are complete.

The Contractor shall prepare an annual specific and updated Snow Clearing and Ice Control Operations Plan that meets the requirements of Section 400.3 (Winter Maintenance Operation Requirements). The plan must be acceptable to the Department and in place by September 15th of each year.

During a Major Snowfall Event (as defined below), the Contractor shall provide a minimum level of snow removal service that includes maintaining one driving lane open in both directions (including on/off ramps). The Contractor shall return to the snow removal effort required to achieve Bare Pavement conditions as soon as the snowfall begins to subside. A “Major Snowfall Event” is defined as one where there is heavy

snowfall over a short duration, accumulation of more than 2 cm/hour, or snowfall greater than five days in duration.

The Snow Clearing and Ice Control Operations Plan must provide for the deployment of snowplows and spreader equipment capable of meeting the following objectives:

- The New Infrastructure roadways must be open to the driving public at all times, unless the Department closes the road;
- All lanes remain operational during snow conditions;
- Plowing shall commence prior to snow accumulation reaching 15 mm on any roadway. The maximum allowable accumulation of loose snow on the roadway is to be 30 mm;
- The deployment of snowplows and spreader units shall be calculated based on these requirements and the locations of the Contractor’s sand and salt stockpiles;
- If required to meet labour and plowing standards and/or where storm intensities are beyond the capabilities of the normal snow removing equipment complement during storms which last more than 48 hours, identify a procedure for obtaining and deploying additional resources;
- Snowplows and spreader units shall respond within the applicable response times;
- Include a contingency plan to address storm conditions which may force the closure of the roadway facility or instances where traffic prevents the deployment of the standard snowplow/equipment complement;
- Plowing coverage shall provide for the continuous integrated plowing of both shoulder and surface of the roadway facility including interchange ramps, intersections and cross-roads;
- Snowplowing on bridges shall be done to prevent snow from being thrown onto underlying roadway or railways;
- A plan for meeting the Winter Maintenance Operation Requirements, in case of a winter storm or winter driving conditions, during the non-winter months;
- Address the cover-off of equipment operators who meet their “Hours of Service” limits or tire. Provide cover-off operators and ensure all equipment remains operational and operated, for the duration of the storm and for the clean-up periods;
- Provide for the provision of regular winter condition reporting to the Department and the Alberta Motor Association (“AMA”) or any other agency identified by the Department; and
- Coordinate winter maintenance with the Local Authority.

The accepted Snow Clearing and Ice Control Operations Plan shall be adhered to throughout the Operating Period.

400.3.2 EQUIPMENT AND MATERIALS

The Contractor’s Snow Clearing and Ice Control Operations Plan (see Section 400.3.1) shall include periods for which the level of equipment shall be available throughout the

winter months and identify levels of equipment that will be available during non-winter months to respond to snow falls during these periods.

Specifications for plow and sanding trucks shall, as a minimum, be in accordance with applicable law, including without limitation the *Traffic Safety Act* (Alberta) and any regulations thereunder and any replacement or successor legislation, and applicable Department standards, as identified in *Alberta Transportation Maintenance Contracts for Rural Highways*.

Sand and salt materials shall be stored in a manner identified in the EMS (Section 100.2.2). The TAC *Synthesis of Best Practices – Road Salt Management* shall be used as a guideline. The Contractor shall adjust the materials storage and handling practices as necessary to address changes or developments in the environmental concerns for any of the materials used.

400.3.3 SNOW CLEARING AND ICE CONTROL OPERATIONS

The Contractor shall conduct all winter maintenance activities with the objective of achieving Bare Pavement (as defined in Section 400.3.1) conditions as quickly as possible and in all cases within the stipulated time periods. Activities shall comply with the accepted Snow Clearing and Ice Control Operations Plan (see Section 400.3.1) and the following:

- The required complement of snowplows shall be deployed within the time limits identified;
- Emergency vehicles and equipment shall be deployed on the roadway system in the event that the standard equipment complement cannot meet Section 400.3 (Winter Maintenance Operation Requirements);
- Snowplows and sand/salt spreader trucks shall be operated in accordance with applicable laws and regulations;
- Snow/ice equipment shall be operable and operated on a 24 hour basis, throughout the Storm Events (as defined in Section 400.3.1) and subsequent clean up;
- All equipment shall be operated with due diligence to prevent damage to the New Infrastructure, and with due regard for the safety of the travelling public; and
- The Contractor shall be responsible for any and all damages.

400.3.3.1 Measuring for Compliance

The Contractor shall monitor its performance relative to Section 400.3 (Winter Maintenance Operation Requirements) and record all response times and snow and ice accumulations in a maintenance management record which shall be provided to the Department on a monthly basis.

400.3.3.2 Non-Compliance

If the Contractor fails to comply with any of Section 400.3 (Winter Maintenance Operation Requirements), despite such a failure, the Contractor shall immediately mobilize in order to minimize snow and ice accumulations.

If non-compliance is observed, Payment Adjustments will be assessed against the Contractor.

Non-compliance is defined as any one of the following:

- The Contractor fails to deploy equipment in accordance with the accepted Snow Clearing and Ice Control Operations Plan (see Section 400.3.1);
- The Contractor has failed to deploy additional resources in accordance with the Snow Clearing and Ice Control Operations Plan;
- The Contractor has failed to plow/remove and/or apply materials as identified in the accepted Snow Clearing and Ice Control Operations Plan;
- The Contractor failed to meet the deployment time frames;
- The Contractor fails to achieve Bare Pavement (as defined in Section 400.3.1) or no ice conditions within the specified time frames following the end of a Storm Event (as defined in Section 400.3.1); and
- The Contractor fails to supply any ice control materials.

400.3.3.3 Payment Adjustments

When the Contractor is non-compliant, Payment Adjustments shall be made as follows:

- \$10,000 for each occurrence of non-compliance during a Storm Event (to a maximum of \$60,000 total for the Infrastructure);
- \$20,000 for each occurrence of non-compliance during a subsequent Storm Event in any consecutive 12 month period (to a maximum of \$120,000 total for the Infrastructure); and
- The third occurrence of any non-compliance within a consecutive 12 month period but in a separate third Storm Event shall be a potential Termination Event for the purposes of and having the consequences set out in Section 16.8(k) of the DBFO Agreement.

The number of occurrences of non-conformance shall be determined for a consecutive 12 month period.

The Department shall notify the Contractor after the first and second occurrences of non-compliance in any consecutive 12 month period. In this section, “occurrence” refers to an occurrence anywhere on the Infrastructure.

400.3.4 PREFERENTIAL BRIDGE DECK ICING

The Contractor shall implement and carry out the Preferential Bridge Deck Icing Plan (see Section 100.2.9). For the purposes of the Technical Requirements, “preferential bridge deck icing” shall mean ice formation within the driving lanes of a bridge deck during a weather circumstance when ice formation within the driving lanes of the roadway leading to and from such bridge deck is not occurring.

400.3.4.1 Measuring for Compliance

The Contractor shall monitor its performance relative to the Preferential Bridge Deck Icing Plan and record all occurrences of preferential bridge deck icing and response times in a maintenance management record which shall be provided to the Department on a monthly basis.

400.3.4.2 Non-Compliance

The Contractor shall be in non-compliance under this Section 400.3.4.2 if preferential bridge deck icing is observed within any of the driving lanes on any of the PBD Bridges (as defined in Section 200.2.16) and either:

- such icing has occurred as the result of the Contractor’s failure to comply with the current Preferential Bridge Deck Icing Plan; or
- upon becoming aware of such preferential bridge deck icing, the Contractor fails to immediately mobilize in order to reasonably minimize such preferential bridge deck icing; or
- preferential bridge deck icing has previously occurred on any of the PBD Bridges under the same Preferential Bridge Deck Icing Plan during a prior distinct weather circumstance occurring in the prior 12 month period,

(each a “Preferential Bridge Deck Icing Non-Compliance Event”).

400.3.4.3 Payment Adjustments

When the Contractor is non-compliant pursuant to Section 400.3.4.2, Payment Adjustments shall be made as follows:

- \$10,000 for each occurrence of a Preferential Bridge Deck Icing Non-Compliance Event during a distinct weather circumstance (to a maximum of \$60,000 total for the Infrastructure) (the “First Set of Occurrences”);
- \$20,000 for each occurrence of a Preferential Bridge Deck Icing Non-Compliance Event following the First Set of Occurrences during a subsequent but separate and

distinct weather circumstance in any consecutive 12 month period (to a maximum of \$120,000 total for the Infrastructure) (the “Second Set of Occurrences”); and

- The third occurrence of any Preferential Bridge Deck Icing Non-Compliance Event within a consecutive 12 month period but during a separate and distinct weather circumstance shall be a potential Termination Event for the purposes of and having the consequences set out in Section 16.8(k) of the DBFO Agreement.

The number of occurrences of non-compliance shall be determined for a consecutive 12 month period.

The Department shall notify the Contractor after the First Set of Occurrences and the Second Set of Occurrences in any consecutive 12 month period. In this section, “occurrence” refers to an occurrence anywhere on the Infrastructure.

400.3.4.4 Plan Replacement

The Contractor shall be entitled at any time to replace the Preferential Bridge Deck Icing Plan provided such replacement plan shall be reasonably designed to prevent preferential bridge deck icing from occurring on the PBD Bridges (as defined in Section 200.2.16) , including without limitation be reasonably designed to rectify any previous failures in preventing preferential bridge deck icing, and is reviewed in accordance with Schedule 5 (Design and Plan Certification and Review Procedure).

400.4 ROADWAYS

400.4.1 ROADWAY MAINTENANCE REQUIREMENTS

The Contractor shall maintain the entire pavement structure, appurtenances, and all associated works in accordance with the performance requirements, until the end of the Operating Period. All areas of pavement including shoulders and gores shall be maintained to similar conditions as the driving lanes.

400.4.1.1 Measuring and Testing For Compliance

The Contractor shall be proactive in maintenance of the roadways and appurtenances and shall test conformance with the performance requirements on a minimum of an annual basis or as stipulated by the Technical Requirements. The Contractor shall schedule testing prior to August 1st of each year so that any required repairs can reasonably be completed in the same calendar year.

For each of the Technical Requirements, the Department may also conduct measurements for compliance and advise the Contractor of any deficiencies.

400.4.1.2 Completing Repairs

When a specific deficiency is identified and times are not defined in the following sections, the Contractor shall correct the work such that it complies with the performance requirements in accordance with the following:

- If the Contractor is aware, or should have been aware, of the deficiency prior to September 1st in any calendar year, the Contractor shall complete the repairs prior to October 31st of the same calendar year;
- When a deficiency with respect to Section 400.4.2.4 (Cross-Slope and Superelevation) or Section 400.4.3 (Smoothness Requirements) is identified during the Operating Period the Contractor shall correct the work such that it complies with the performance requirements by July 31 of the following year; or
- If the Contractor is aware or should have been aware of the deficiency after September 1st in any calendar year, the Contractor shall complete the repairs prior to June 30th of the following calendar year.

For all deficiencies, the Contractor shall complete the repairs within these timelines. Failure to do so will result in the applicable Payment Adjustments being assessed. Notwithstanding the allowances for delaying repairs over the winter period the Contractor shall schedule testing to allow time for required repairs within the calendar year. In the event that the Contractor is aware of a deficiency after September 1 due to

delays in testing, the specified Payment Adjustment will be assessed for the period until repairs are complete, including the winter period.

400.4.2 PAVEMENT GEOMETRIC REQUIREMENTS

The Contractor shall maintain all roadway sections to the designed lines and grades. The following tolerances shall be met. Tolerances refer to the finished pavement surface.

400.4.2.1 Cross-Slope and Superelevation Rates

The roadway superelevation and cross-slope rates shall be maintained to be within $\pm 0.2\%$ of the design rates immediately after construction and within $\pm 1.0\%$ of the design rates during the Operating Period.

400.4.2.2 Pavement Widths

The pavement surface width shall be constructed and maintained to the width defined by the standard cross section for the specific area of roadway. The mainline pavement surface width shall not be more than 0.35 m less than the design width immediately after construction and shall not be less than the design width after any pavement rehabilitation undertaken during the Operating Period.

400.4.2.3 Measuring For Compliance

The Contractor shall measure the roadway superelevation and cross-slope immediately prior to Traffic Availability and after each major surface rehabilitation and whenever the surface appears to not meet the superelevation and cross-slope requirements. Notwithstanding the foregoing, the Department may elect to test or measure the roadway independently if there are concerns regarding the serviceability of the roadway.

The pavement width shall be measured following initial construction and after each rehabilitation which has an impact on roadway width, by means of conventional survey techniques at a minimum of 20 equally spaced measurements per kilometre.

For measurements made using inertial profiling devices, the limiting values will apply to each 100 m segment of the roadway and the average value determined for each consecutive one km section based on the absolute value of the difference in measured and designed cross-slope or superelevation. For width measurements an average value per kilometre, or fraction thereof, shall be determined based on measurements each 50 m.

If the results of the measurements indicate that the work does not comply with the specified criteria, the work will be deemed to be deficient and the Contractor shall

schedule remedial work within the specified time period indicated in Section 400.4.1.2 (Completing Repairs).

Measurements for cross-slope and superelevation shall be made by the Contractor immediately prior to Traffic Availability and then as a minimum of once every three years thereafter using a laser based Class I inertial profiling device as defined by ASTM E950, or better. Measurements made using an inertial profiler device shall be averaged for 100 m segments of the roadway.

Cross-slope and superelevation measurements shall be collected for each lane on a continuous basis and reported at 50 m intervals. The measurements shall be made across the entire lane width utilizing an inertial profiling vehicle combining a vehicle frame referenced inertial measurement unit (“IMU”) with a minimum roll accuracy of 0.01° and a minimum of 10 height sensors. Continuous cross-slope and superelevation measurements shall be calculated based on the linear best fit of the measured transverse profile averaged for each 100 m lane segment of the roadway. The cross-slope and superelevation shall be collected to an accuracy of +/- 0.02 percent and reported to +/- 0.1 percent for each 100 m lane segment.

The Contractor shall conduct an on-site verification prior to the start of the measuring for compliance. The cross-slope and superelevation equipment verification will be based on direct comparison with manually measured transverse profiles at verification sites established by the Department for the evaluation of inertial profiling devices on local area roadway(s). This verification validates the cross-slope and superelevation measurements of the inertial profiling device by using direct comparisons to known roadway geometry. The Contractor is required to run the inertial profiling device over the specified site(s) three times to determine the accuracy and repeatability of the inertial profiling device. The average cross-slope and average superelevation over the 500 m site(s) derived through the automated data collection must be within 0.1 percent of the average cross-slope and superelevation derived through manual survey. The values derived from the automated data collection will be considered repeatable if the values from each run are within +/- 1 standard deviation of the mean for the three runs.

400.4.2.4 Payment Adjustments

Payment Adjustments shall be assessed on a \$/lane-km basis for cross-slope and superelevation rate measurement. Pavement width Payment Adjustments shall be assessed on a \$/km basis for width variations. Payment Adjustments shall apply to full or partial kilometres and full or partial weeks and shall be assessed until the deficiency is corrected.

Payment Adjustments:

(a) Cross-Slope and Superelevation:

If following construction and prior to the New Infrastructure being opened for use by the public, the roadway superelevation and cross-slope rates are measured and are found not to be maintained within $\pm 0.2\%$ of the design rates then the New Infrastructure shall not be opened for use by the public and no Payment shall be paid until such time as the deficiency is corrected.

If during the Operating Period, the roadway superelevation and cross-slope rates are measured and are found not to be maintained within $\pm 1.0\%$ of the design rates then the following Payment Adjustments will apply:

- \$3,000/week or any partial week, for the first four weeks the deficiency is not remedied; then
- \$9,000/week or any partial week, thereafter.

Percentages refer to a numeric deviation from the designed percentage not a percentage deviation. i.e. if the designed percentage is 6% the deviation referred to in the pre-public use scenario is $> 5.8\%$ and $< 6.2\%$, and $> 5.0\%$ and $< 7.0\%$ in the operations scenario.

(b) Pavement Width Less than Design Width (Mainline):

If following construction and prior to the New Infrastructure being opened for use by the public, the mainline pavement surface width is measured and is found to be up to 0.35 m narrower than the design width then any Payment shall be reduced by an amount equal to the length of the non-conforming roadway, rounded to the next highest kilometre, multiplied by \$90,000/km.

If following construction and prior to the New Infrastructure being opened for use by the public, the mainline pavement surface width is measured and is found to be more than 0.35 m narrower than the design width then the New Infrastructure shall not be opened for use by the public and no Payment shall be paid until such time as the deficiency is corrected.

If after pavement rehabilitation, the mainline pavement surface is measured and is found to be less than the design width then the Contractor must repair the deficiency within the timeframes specified in Section 400.4.1.2 (Completing Repairs). A failure to repair such deficiencies shall be a potential Termination Event for the purposes of and having the consequences set out in Section 16.8(k) of the DBFO Agreement.

(c) Pavement Width Less than Design Width (C-D Roads, Ramps and Crossroads):

If following construction and prior to the New Infrastructure being opened for use by the public, the pavement surface width on C-D roads, ramps or crossroads is measured and is found to be less than the design width then the New Infrastructure shall not be opened for

use by the public and no Payment shall be paid until such time as the deficiency is corrected.

If after pavement rehabilitation, the pavement surface width on C-D roads, ramps or crossroads is measured and is found to be less than the design width then the Contractor must repair the deficiency within the timeframes specified in Section 400.4.1.2 (Completing Repairs). A failure to repair such deficiencies shall be a potential Termination Event for the purposes of and having the consequences set out in Section 16.8(k) of the DBFO Agreement.

400.4.3 SMOOTHNESS REQUIREMENTS

The roadways shall be maintained with an International Roughness Index (“IRI”) value equal to or less than those shown in the following table:

Design Speed (km/hr)	Specified IRI (mm/m)
> 110	1.9
> 90 ≤ 110	2.0
> 70 ≤ 90	2.2
≤ 70	2.4

at all times based on a one kilometre average value for each lane. For any individual 100 m long section the IRI shall be maintained at less than 1.0 mm/m greater than the IRI value noted above.

400.4.3.1 Measuring For Compliance

Measurements shall be made by the Contractor immediately prior to Traffic Availability and then at a minimum of once every three years thereafter using a laser based Class 1 inertial profiling device as defined by ASTM E950, or better. The IRI shall be determined in accordance with ASTM E1926 and the recommended “*Best Practice Guidelines*” contained within “*Standardization of IRI Data Collection and Reporting in Canada*” as published by the Transportation Association of Canada. In addition to the “*Best Practice Guidelines*”, the IRI for each lane in each direction is to be determined, anomalous roughness events are to be identified with an event “log” during data collection, the start and end limits are to be identified, the data is to be collected during the same week from year to year, and where “should” is used in the TAC “*Best Practices Guidelines*” it means that it must be done.

The Contractor shall conduct an on-site verification prior to the start of the measuring for compliance. The profile measurement and IRI post-processing and reporting verification will be based on direct comparison with manually measured longitudinal profiles in each wheel path at verification sites established by the Department for the evaluation of

inertial profiling devices on local area roadway(s). The Contractor is required to run the inertial profiling device over the specified site(s) three times to measure the accuracy and repeatability of the inertial profiling device. The average IRI values for each wheel path over the 500 m site(s) derived through the automated data collection must be within 10% of the IRI derived through manual survey. The values derived from the automated data collection will be considered repeatable if the values from each run are within 5% of the mean for the three runs.

The limiting IRI values will apply to the average value determined for each consecutive one km section of each lane. All average IRI values will be collected to the nearest 0.01 mm/m and reported to the nearest 0.1 mm/m value.

If the results of the tests or measurements indicate that the work no longer complies to the specified criteria, the work will be deemed to be non-compliant and the Contractor shall undertake the necessary work to address the non-compliance.

400.4.3.2 Payment Adjustments

If the repairs are not completed within the applicable specified time period in Section 400.4.1.2 (Completing Repairs), the Contractor shall be assessed the following Payment Adjustments. The Payment Adjustment shall apply to full or partial lane-kilometres and will be assessed until the deficiency is corrected.

Payment Adjustments:

*Deviation from Specified IRI Value (mm/m for 1 lane-km average)	Payment Adjustment (\$/lane-km)
After initial construction <1.0 below specified	No payment, cannot open roadway
During operations >0.3 more than specified - must fix in specified time period	\$3,000/week or any partial week, for first 4 weeks, then \$9,000/week or any partial week, thereafter
Deviation from Specified IRI Value +1.0 (mm/m for 100 m lane sections)	Payment Adjustment (\$/100 m lane section)
After initial construction <1.0 below specified	No payment, cannot open roadway
During operations >0.3 more than specified - must fix in specified time period	\$3,000/week or any partial week, for first 4 weeks, then \$9,000/week or any partial week, thereafter

* Deviation refers to the numeric difference from the specified IRI value, i.e. if the design speed was 110 kph the roadway must be maintained at an IRI of less than 2.0 mm/m. If the measured IRI during the Operating Period was greater than 2.3, then a Payment Adjustment would apply.

Payment Adjustments for lane-km averages are based on the average of both wheelpath test results and Payment Adjustments shall apply to full or partial lane-kilometres. The Payment Adjustment assessment for individual 100 m sections shall be based on the

average of both wheelpath test results and Payment Adjustments shall apply to each 100 m section of non-compliance.

400.4.4 RUTTING PERFORMANCE REQUIREMENTS

The roadway shall be maintained with rut depths of less than 14 mm at all times based on one km average values. For 100 m sections the rut depths shall be maintained to be less than 19 mm and for any isolated section, less than 25 m in length, the rut depths shall be maintained to less than 29 mm.

400.4.4.1 Measuring For Compliance

Measurements shall be made by the Contractor immediately prior to Traffic Availability and then at a minimum of once every three years thereafter using a laser based Class 1 inertial profiling device as defined by ASTM E950, or better and equipped with a minimum of 10 lasers. Testing shall be performed during the same week for each test year. Rut depth measurements shall be collected for each lane on a continuous basis and reported at 50 m intervals. Rut depth measurements made with an inertial profiling device shall be averaged for each 100 m lane segment of the roadway for each wheel path of each lane. The rut depths shall be collected to an accuracy of +/- 0.5 mm and reported to +/- 1 mm for each 100 m lane segment.

The Contractor shall conduct an on-site verification prior to the start of the measuring for compliance. The wheel path rut depth measurement equipment verification will be based on direct comparison with manually measured transverse profiles at verification sites established by the Department for the evaluation of inertial profiling devices on local area roadway(s). The Contractor is required to run the inertial profiling device over the specified site(s) three times to measure the accuracy and repeatability of the inertial profiling device. The average rut depth over the 500 m site(s) derived through the automated data collection must be within +/- 2 mm of the average rut depth derived through manual survey. The values derived from the automated data collection will be considered repeatable if the values from each run are within +/- 1 standard deviation of the mean for the three runs.

Measurements of localized areas shall be carried out using a 1.8 m straight edge in accordance with ASTM E1707.

The limiting rut depth values will apply to the average value determined for each consecutive one km section for each lane. Additionally, for each lane, each individual 100 m section rut depth value shall be <19 mm and all localized areas shall be maintained to have rut depth measurements of <29 mm. Localized areas shall be determined for individual wheel path locations, all other rut measurements will be based on the average of both wheel path locations, for each lane. All average rut values shall be rounded down to the nearest mm and reported as an integer value.

If the results of the tests or measurements indicate that the work no longer complies to the specified criteria, the work will be deemed to be non-compliant and the Contractor shall undertake the necessary work to address the non-compliance.

400.4.4.2 Payment Adjustments

If the repairs are not completed within the applicable specified time period, Section 400.4.1.2 (Completing Repairs), the Contractor shall be assessed a Payment Adjustment. The \$/lane-km value shall apply to full or partial kilometres and shall be assessed until the deficiency is corrected.

Payment Adjustments:

Average Rut Depth (mm)(1 km average)	\$/lane-km	Rut Depth (mm) in excess of Specified Maximum (100 m section)	\$/Lane 100 m Section	Rut Depth (mm) in excess of Specified Maximum (Isolated Deficiency)	\$/Isolated Deficiency
After initial construction >0	No payment, cannot open roadway	After initial construction >0	No payment, cannot open roadway	After initial construction >0	No payment, cannot open roadway
During operations >14 - must fix within specified time period	\$3,000/ week or any partial week, for first four weeks, then \$9,000/week or any partial week, thereafter	During operations >19 - must fix within specified time period	\$3,000/week or any partial week, for first four weeks, then \$9,000/week or any partial week, thereafter	During operations >29 - must fix within specified time period	\$2,000/week or any partial week, for first four weeks, then \$6,000/week or any partial week, thereafter

Payment Adjustments for lane-km averages are based on both wheel path test results. The Payment Adjustment for individual 100 m sections applies to the average of both wheel paths except that isolated sections shall be based on individual wheelpaths and can result in a Payment Adjustment based on both wheel-paths at the same station location. The Payment Adjustment for 100 m sections applies to each 100 m section of non-compliance.

400.4.5 SKID RESISTANCE REQUIREMENTS

ASTM E274 or alternate testing methods, as approved by the Department, shall be used to determine the skid resistance of the pavement along the New Infrastructure.

ASTM E 1960 shall be used to determine the calibrated wet friction at 60 km/h (F60) and the speed constant of wet pavement friction (SP). The resulting International Friction Index (“IFI”) shall be reported along with the actual skid numbers determined.

Areas of pavement which exhibit a physical appearance of polishing, flushing or bleeding and/or which exhibit a higher than average incidence of accidents shall be tested for skid resistance.

400.4.5.1 Measuring For Compliance

After Traffic Availability, areas of pavement on the New Infrastructure which exhibit a visual appearance of polishing, flushing or bleeding and/or which exhibit a higher than average incidence of accidents shall be tested for skid resistance within 30 days of the date which the Contractor first became aware, or the date which the Contractor should have been aware, of such conditions, weather permitting.

400.4.5.2 Completing Repairs

If results of the tests or measurements indicate that the New Infrastructure no longer complies to the specified criteria, the New Infrastructure will be deficient, requiring repair. When a specific deficiency is identified, the Contractor shall correct the work such that it complies with the minimum requirements within 60 days.

400.4.5.3 Payment Adjustments

If the repairs are not completed within the applicable specified time period, the Contractor shall be assessed a Payment Adjustment. The \$/lane-km value shall apply to full or partial kilometres and will be assessed until the deficiency is corrected.

During operations, Skid Number < 30 - must
fix within specified time period

\$3,000/lane-km/week or any partial
week, for first four weeks, then
\$9,000/lane-km/week or any partial
week.

400.4.6 GENERAL PAVEMENT MAINTENANCE REQUIREMENTS

The Contractor shall maintain all pavement sections including shoulders and gore areas on a regular basis in order to ensure that they remain in a structurally sound and safe condition and continue to provide the service for which they were intended.

The Contractor shall maintain the pavement surface in a safe condition. If a pavement deficiency is a hazard to motorists, it shall be repaired immediately regardless of size. The following sections provide detailed requirements.

400.4.6.1 Localized Deficiencies

Localized deficiencies within any travel lane which are > 0.1 square metre shall be repaired within 24 hours following the time when the Contractor became aware, or should have become aware, of the deficiency. Localized deficiencies which are not located within the travel lanes and/or do not exceed 0.1 square metres shall be repaired within 21 days following the time when the Contractor became aware, or should have become aware, of the deficiency. Spalling or other distress at crack locations and joints shall be treated as a localized deficiency.

400.4.6.2 Localized Roughness

All areas of the pavement shall be maintained true to lines and grades. Localized areas, such as transverse cracks or joints, shall be maintained to prevent localized roughness. Deficiencies which cause localized roughness shall be repaired. The definition of localized roughness shall be any abrupt deviation in excess of 6 mm when measured with a 1.2 m straight edge.

400.4.6.3 Measuring For Compliance

The Contractor shall inspect the New Infrastructure on a continual basis as part of the schedule of inspection, and shall identify deficiencies related to Section 400.4.6 (General Pavement Maintenance Requirements).

400.4.6.4 Completing Repairs

The Contractor shall undertake any required repairs within the time lines indicated for the specific maintenance need. Where a specific timeline is not indicated, the repairs shall be undertaken within 30 days of the time the Contractor became aware, or should have become aware, of the deficiency. Maintenance repair requirements apply year-round and may be required during poor weather conditions.

400.4.6.5 Payment Adjustments

If repairs, permanent or otherwise, are not completed within the stipulated time period, the Contractor shall be assessed Payment Adjustments at a rate of \$500/required repair for each seven day period or any partial week, until the deficiency is corrected.

400.4.7 MISCELLANEOUS - OPERATION AND PERFORMANCE REQUIREMENTS

This Section 400.4.7 covers the performance requirements of specific appurtenances and maintenance activities that must be performed to a specified standard by the Contractor. Notwithstanding the foregoing sentencing but subject to the DBFO Agreement, all infrastructure associated with this New Infrastructure shall be maintained in an adequate condition and function as designed.

Non-specified items of the New Infrastructure such as, but not limited to, backslope, sideslope, or embankment movements, fencing, and pavement shoulders or gore areas shall be maintained to a level consistent with standard practice. Non-specified items shall be monitored and maintained in accordance with standard industry practice. The timing for completing repairs detailed in Section 400.4.1.2 (Completing Repairs), will apply except as specifically noted.

400.4.7.1 Delineators

Delineators shall be maintained clean at all times and shall exhibit a minimum retroreflectivity of 80% of design value.

The Contractor shall maintain delineator guideposts plumb within 50 mm throughout their length.

Delineators shall be maintained within 5% of design height and shall not deviate from design locations by more than 50 mm.

Delineators shall be maintained to provide the intended delineation at all times. Delineators that are damaged, or otherwise removed, such that they are not providing the desired delineation shall be replaced.

400.4.7.1.1 Measuring For Compliance

The Contractor shall identify damaged, missing or otherwise ineffective delineators during roadway inspections. At least once per year, the Contractor shall complete a visual inspection and, when required (i.e. vertical alignment more than 50 mm out of plumb), shall realign delineator guideposts to within 13 mm of plumb throughout their length.

400.4.7.1.2 Completing Repairs

Delineators that become soiled shall be cleaned within seven days providing weather conditions permit.

Delineators that are damaged, missing or otherwise fail to function as designed, shall be replaced within seven days.

400.4.7.1.3 Payment Adjustments

Payment Adjustments shall be assessed against the Contractor for each delineator which does not comply with the requirements of this Section 400.4.7.1 within the stipulated time period at a rate of \$20/delineator/day or any partial day, until made to comply.

400.4.7.2 Roadway Lighting

Roadway lighting includes all lights designed and constructed for the New Infrastructure or subsequently added to the New Infrastructure. The Contractor shall undertake the necessary maintenance to ensure that the desired illumination is provided to motorists at all times. The Contractor shall inspect the operation of the entire roadway lighting system, including the structural integrity of components, power supply, conduit, cables and equipment on a regular basis and this shall be included in the Contractor's QMS (Section 100.2.1). The following shall apply:

- Lighting shall be maintained and operated to provide the level of illumination as designed;
- Poles shall be maintained plumb within 10 mm in 1 m;
- Poles and other mounting hardware shall be maintained in a clean and neat repair, with no corrosion visible;
- Concrete bases shall be maintained to be structurally adequate for the design loads;
- Individual lights/luminaires shall be maintained to provide light output in accordance with the manufacturer's rated design parameters and overall illumination in accordance with the Detailed Designs; and
- All portions of the installation and any repairs or modifications shall comply fully with the Detailed Designs and construction requirements and any applicable codes.

400.4.7.2.1 Measuring for Compliance

The Contractor shall conduct a regular monitoring program for evaluating the condition of all roadway lights, including all supporting infrastructure, within the New Infrastructure. The Department may inspect lights at any time and notify the Contractor of any non-compliance to the Technical Requirements.

400.4.7.2.2 Completing Repairs

The Contractor shall undertake repairs within the following guidelines, from the time that the deficiency is known, or should have been known, to the Contractor:

- Outage of 2 or less consecutive lamps shall be repaired within 96 hours.

- Outage of 2 to 5 consecutive lamps shall be repaired within 72 hours.
- Outage of more than 5 consecutive lamps shall be repaired within 48 hours.
- Repair or replacement of lighting infrastructure damaged by an accident shall be done within seven days.

An outage is defined as total failure of the lamp to light, failure of the lamp to produce the manufacturer's rated output (to such an extent that it is visually apparent when compared to other lamps), intermittent lighting caused by cycling on and off, or light is prevented from being properly distributed to the roadway surface.

Poles which are out of alignment more than allowed in the Technical Requirements shall be corrected within 60 days. Any condition of poles or concrete foundations that affect the structural integrity of the installed lighting system shall be repaired within 20 days except for high mast systems, which shall be repaired within five days.

When the work necessitates the replacement of lighting structures, only new materials shall be used.

400.4.7.2.3 Payment Adjustments

The Contractor shall be assessed Payment Adjustments for failing to adjust, maintain, repair/replace lamps or components of the roadway lighting system within the stipulated time as follows:

- Lamp repair/replacement, \$100/lamp/day or any partial day, that the lamp remains in need of repair/replacement; and
- Repair or adjustment of any pole, base or other lighting system component, \$100/component/day or any partial day, that the component needs adjustment.

400.4.7.3 Barriers and Guardrail

Barriers and guardrail shall be maintained to function as designed and to have a neat and tidy appearance at all times. The following shall apply:

- Guardrail that is dented, bent, twisted or otherwise misaligned shall be repaired or replaced. Barriers and guardrail shall be maintained in proper alignment, as designed, at all times. Permissible tolerances for plumb and horizontal grades shall be 20 mm from design grades. Permissible tolerances for vertical grades shall be 40 mm from design grade;
- Barriers and guardrail shall be visible at all times and reflective markers shall be clean and function as designed;
- Guardrail damaged by collision shall be replaced. When guardrail is damaged it shall be repaired immediately to assure the continued protection of the travelling public.

When immediate permanent repair is not possible, temporary repairs shall be implemented immediately;

- Posts which are structurally unsound, loose, out of plumb, or otherwise failing to provide the required functionality, shall be replaced;
- All components shall be securely fastened with the designed fasteners at all times; and
- Concrete barrier that has concrete pieces missing or structural weakening shall be replaced.

400.4.7.3.1 Measuring for Compliance

The Contractor shall undertake daily inspections of all barriers and guardrail sections within the New Infrastructure.

400.4.7.3.2 Completing Repairs

In situations when barriers or guardrails are missing or damaged such that they do not function as intended, the Contractor shall undertake repairs or temporarily protect the area immediately. All other non-compliant sections of barrier or guardrail shall be repaired within 60 days. In instances where temporary repairs are required, such temporary repairs may not be in place for more than five days. In winter months when permanent repairs may not be possible due to freezing conditions, temporary measures may stay in-place until the ground is free of frost.

400.4.7.3.3 Payment Adjustments

Following the expiration of the specified time-frame for completing repairs, or in the case where temporary repairs have been in-place until weather permits repairs to be more reasonably undertaken, a Payment Adjustment of \$200/metre/day or any partial day, of non-compliant barrier or guardrail shall be assessed until the repairs are completed.

400.4.7.4 Grass Cutting and Landscape Maintenance

400.4.7.4.1 General

The Contractor shall maintain the vegetation in all areas of the Road Right of Way and stormwater management facilities. The Contractor shall remove and dispose of any dead vegetation and re-seed grass, if necessary, to retain the overall landscaping within the Road Right of Way and stormwater management facilities.

Grass within the Road Right of Way and stormwater management facilities shall not exceed 300 mm in height, at any time

Weed control shall be carried out, by the Contractor, as required to control noxious weeds including all noxious weeds identified under the *Weed Control Act* (Alberta) and Local Authority bylaws.

400.4.7.4.2 Weed Control

400.4.7.4.2.1 Operating Standards, Approvals and Permits

The Contractor shall comply with the operating standards and practices of the Industrial Vegetation Management Association of Alberta and shall have a service approval agreement from Alberta Environment, or its successor. All personnel applying chemicals shall have a valid applicators license issued by Alberta Environment, or its successor.

Special use approvals issued by Alberta Environment, or its successor, will be required in instances where chemicals are to be sprayed within 30 m of an open body of water. In such instances, the Contractor shall advertise the proposed work in newspapers local to the area, 30 days prior to the scheduled starting date of the work.

The Contractor shall provide the Department with a copy of the newspapers containing the advertisement. All public concerns shall be referred, by the Contractor, to Alberta Environment, or its successor, who will identify any work conditions in the approval. The Contractor shall be responsible for obtaining the special use approval and shall comply with the conditions specified therein.

The Contractor is liable for any damage caused to areas outside the Road Right of Way occasioned by its use of chemicals for weed control and shall promptly handle any damage claims in this regard. The Contractor shall also pay any fines/penalties assessed by the governing authority for failure to promptly comply with applicable requirements.

400.4.7.4.2.2 Materials

The Contractor shall select and supply the appropriate chemical for vegetation control. Only chemicals approved by the appropriate department of the Federal Government for general industrial spraying shall be used. The Contractor shall supply any signs required to identify treated areas in public use areas.

400.4.7.4.2.3 Procedures

The Contractor's use of chemicals, application rates and methods shall comply with the policies, rules and regulations of Alberta Environment, or its successor. The Contractor shall maintain accurate records of all applications including the type and amounts of chemicals used and the locations treated. If requested, the Contractor shall supply this information to the Department along with copies of the bills of lading and the manufacturer's recommended application rates for the chemicals used. The Contractor shall dispose of empty chemical containers only at approved disposal sites.

400.4.7.4.3 Measuring for Compliance

The Contractor shall undertake periodic inspections of all areas of the Road Right of Way and stormwater management facilities to assess the need for any type of landscape maintenance including grass cutting, re-seeding/re-planting, weed control and the removal of dead vegetation. The monitoring program shall comply with the program documented in the Contractor's EMS (Section 100.2.2). The Department may inspect landscaping at any time and notify the Contractor of any non-compliance to these specifications.

Alberta Environment, or its successor, and the Local Authority will also inspect for noxious weeds and any order or direction given to the Contractor regarding deficiencies in compliance shall be dealt with immediately.

400.4.7.4.4 Completing Repairs

When the Contractor fails to observe the need for maintenance, or fails to undertake maintenance within two weeks, then the Contractor will be considered non-compliant and the specified Payment Adjustments will be applied.

400.4.7.4.5 Payment Adjustments

Payment Adjustments shall be assessed against the Contractor on the following basis:

- Grass in excess of the specified maximum height, \$100/hectare or any partial hectare/month or any partial month, for any portion of a hectare that fails to meet these requirements

400.4.7.5 Litter Clean Up

The Contractor shall maintain the Road Right of Way and the drainage system to be reasonably free of litter. The Road Right of Way must be free of any and all litter that may cause damage to vehicles, or otherwise result in a safety hazard for roadway users. The Contractor shall:

- Conduct an annual litter clean up, each spring. Following the annual clean up no litter shall be visible within the Road Right of Way and the drainage system;
- Conduct litter clean up, to the same standard as the spring clean up, on or about July 30, and September 30 each year during the Operating Period. In addition, the Contractor shall clean up any litter that covers more than 0.025 cubic metres (one cubic foot) in size or greater within the Road Right of Way or the drainage system within one week of observing the litter;
- Remove litter, including dead animals, on the roadway that has the potential to affect traffic immediately and dispose of. Dead animals at any other location on the Road

Right of Way or the drainage system shall be removed within six hours of being observed and disposed of;

- Remove abandoned vehicles within 24 hours in co-operation with policing authorities;
- Remove graffiti from any location visible from the roadway within 96 hours. Graffiti that cannot be effectively removed shall be covered with appropriate materials; and
- Remove all waste or other litter generated by the Contractor's operation.

Notwithstanding the above requirements for litter clean-up the Contractor shall work with and coordinate with policing authorities and registered motor vehicle owners and their insurers to facilitate clean up of debris resulting from accidents within the Road Right of Way.

400.4.7.5.1 Measuring for Compliance

The Contractor shall undertake periodic inspections of all areas of the Road Right of Way and drainage system to assess the need for litter clean up.

The Contractor will be considered to be non-compliant with this Section 400.4.7.5 if any of the following occur:

- An annual spring clean-up campaign has not been conducted, or has been conducted but has not removed all visible litter from the Road Right of Way and drainage system, by June 1st of each year;
- The specified summer and fall clean up operations have not been completed by August 15 and October 15 respectively, in each year;
- Litter that poses a hazard has not been removed within the specified time period;
- The Department or the Contractor identifies that the Road Right of Way and drainage system is littered and unsightly and such litter is not removed within the specified time frame;
- Abandoned vehicles are not removed within the specified time frame;
- Graffiti is not removed or appropriately covered within the specified time frames; and
- Waste generated by the Contractor has not been removed within one week of the completion of the work associated with the waste, or if such waste is creating an unsightly or hazardous condition.

400.4.7.5.2 Completing Clean Up

When the Contractor fails to observe the need for litter clean-up, or fails to undertake cleanup required, then the Contractor will be considered non-compliant and the specified Payment Adjustments shall be applied.

400.4.7.5.3 Payment Adjustments

If the Contractor is determined to be non-compliant, a Payment Adjustment of \$250/day, or any partial day, shall be assessed for each and every occurrence of non-compliance. An occurrence is any single or multiple non-compliance. Payment Adjustments for litter clean up are cumulative but shall not exceed \$500/day. The Payment Adjustment shall be assessed for each day, or portion thereof, until the cleanup is completed.

400.4.7.6 Drainage Systems

Drainage systems shall be maintained to function as designed and to assure that environmental requirements are met at all times.

The Contractor shall undertake drainage system maintenance to ensure that the roadway surfaces and all other elements of the New Infrastructure are safe and effectively drained.

The requirements of this section apply to any aspect of the New Infrastructure that serves a drainage function, including, but not limited to:

- Drainage structures;
- Culverts;
- Ditches;
- Stormwater management facilities;
- Curb and gutter (drainage function);
- Manholes, inlet and outlet structures, catch basins, flumes; and
- Storm sewers.

The Contractor shall ensure that environmental requirements required by legislation or design are met at all times and shall maintain all aspects of the drainage facilities to prevent the discharge of silt or sediments into water courses.

Drainage system elements shall be maintained to assure full hydraulic and structural capacity.

Ditches, sideslopes, backslopes and any land within the Road Right of Way, the drainage system and/or parts of the TUC drained by the New Infrastructure system shall be protected from erosion, including wind erosion. The Contractor shall be responsible for any damage to the Road Right of Way, the TUC, or any lands adjacent the TUC caused by a deficiency in the design, construction or maintenance of the drainage system for the New Infrastructure.

The Contractor shall manage the drainage system such that deficiencies are repaired immediately if erosion or sedimentation is a potential, or within one year for all other repairs.

400.4.7.6.1 Measuring for Compliance

The Contractor shall complete regular inspections of the New Infrastructure to assess the function of the drainage systems and to schedule maintenance and repairs.

400.4.7.6.2 Completing Repairs

The Contractor shall plan for and complete repairs to the drainage system on an annual basis. Drainage deficiencies identified by the Contractor's inspection shall be corrected within two months excepting if such repairs are necessary to prevent the potential for ponding of water on the road surface or if potential for erosion or sedimentation exists, in which case repairs shall be made immediately.

400.4.7.6.3 Payment Adjustments

The ponding of water on the road surface at anytime is not acceptable. For each and every case in which ponded water remains on the road surface for greater than 60 minutes, the Contractor shall be assessed a Payment Adjustment per day, or portion thereof, until the water is removed and the cause of the ponding is rectified.

For paved areas with ponds up to 4 m² the Payment Adjustment shall be \$1,000/pond/day or any partial day. For paved areas with ponds in excess of 4 m² a Payment Adjustment of \$5,000/pond/day or any partial day, shall be made.

If erosion of lands occurs, the Contractor shall be assessed a Payment Adjustment if it is not repaired, and the cause rectified within one week of the time of the Contractor becoming aware or should have been aware of the deficiency, of \$500/day or any partial day, until repairs are complete.

For all other drainage system deficiencies, the Contractor shall complete the necessary repairs within the stipulated time period or be assessed a Payment Adjustment of \$100/day or any partial day, for each deficiency, until the deficiency is repaired.

400.4.7.7 Curb And Gutter

Curb and gutter and any associated works shall be maintained to function as designed. References to curb and gutter shall include curb or gutter sections which may exist separately within the New Infrastructure. The following shall apply:

- Curb and gutter shall be maintained to ensure that their function in overall drainage and driver guidance is maintained at all times;
- Curb and gutter shall be maintained to ensure no ponding of water anywhere along the length of the curb, within the gutter or on any roadway or shoulder;
- Broken or damaged concrete shall be replaced when required to restore functionality;

- Scaling of a concrete surface shall be limited to no more than 10% of surface area in any five lineal metre section of curb and gutter;
- Cracking of concrete shall be limited to a maximum crack width of 3 mm, occurring at a maximum frequency of one crack every 2 m; and
- Curb height shall be maintained to meet the requirements of the design specifications and in no case shall be less than 150 mm.

400.4.7.7.1 Measuring for Compliance

The Contractor shall undertake periodic inspections of all curb and gutter sections within the New Infrastructure for the purpose of evaluating the functionality and the condition of the concrete materials.

400.4.7.7.2 Completing Repairs

The Contractor shall complete repairs to restore the functionality of the curb and gutter sections to the level and alignment for which they were originally designed. General repairs shall be completed within 180 days of the time when the Contractor knew of, or should have known of, the deficiency. Replacements of curb and gutter for surface scaling and/or cracking which do not impair functionality shall be completed within 180 days of the time when the Contractor knew or should have known of the deficiency.

400.4.7.7.3 Payment Adjustments

Payment Adjustments for each instance where a curb and gutter section does not conform to the Technical Requirements, and is not repaired within the stipulated time period, shall be \$1,000/occurrence/day or any partial day, until rectified.

400.4.7.8 Sidewalks

Sidewalks shall be maintained to function as designed. The Contractor shall undertake the necessary maintenance to ensure that any sidewalks within the New Infrastructure are maintained in a condition that is safe for pedestrian traffic. The following shall apply:

- Vertical displacement at joints or cracks that exceed 5 mm shall be repaired or replaced to remove the differential elevation and remove any tripping hazard;
- Concrete that is cracked in multiple locations within the same general area of a sidewalk or otherwise results in a discontinuity that may pose a tripping hazard or be a safety concern shall be removed and replaced;
- Concrete surfaces that exhibit scaling over more than 15% of the surface area in any 1 m² section and results in a rough surface texture shall be removed and replaced; and
- Crack widths in excess of 5 mm require repairs or replacement of the sidewalk section(s) affected.

400.4.7.8.1 Measuring for Compliance

The Contractor shall undertake periodic inspections of sidewalks for evaluating the condition of all sidewalks within the New Infrastructure.

400.4.7.8.2 Completing Repairs

The Contractor shall complete repairs to restore the functionality of the sidewalk to the level for which it was originally designed. Repairs shall be completed within 180 days of the time when the Contractor knew of, or should have known of, the deficiency.

400.4.7.8.3 Payment Adjustments

Payment Adjustments for each instance where a sidewalk does not conform to the Technical Requirements, shall be \$1,000/occurrence/month or any partial month, until rectified.

400.4.7.9 Subgrade Sideslopes and Backslopes

Subgrade sideslopes shall be maintained as a uniform, smooth surface or straight line from the edge of pavement to edge of sideslope. Over the Operating Period, the straight line sideslope may vary from the design slope angle by no more than 1%.

Backslopes shall be maintained as a uniform, smooth surface or straight line from the ditch bottom to the top of the slope. Over the Operating Period, the straight line backslope may vary from the design slope angle by no more than 2%.

Depressions or abrupt elevation changes greater than 0.05m, for a distance of 2.0 m down the sideslope shall be repaired by the Contractor. Abrupt changes in slope angle that form a depression greater than 0.1 m from the design straight line or slumping in sideslopes or backslopes shall be repaired by the Contractor.

400.4.7.9.1 Measuring for Compliance

The Contractor shall undertake periodic inspections for evaluating the condition of all subgrade sideslopes and backslopes within the New Infrastructure.

400.4.7.9.2 Completing Repairs

The Contractor shall complete repairs to restore the functionality of the sideslopes and backslopes to the level for which it was originally designed. Areas that require repair within the clear zone shall be completed within 30 days of the time when the Contractor knew of, or should have known of, the deficiency. Other areas requiring repair shall be

completed shall be completed within 180 days of the time when the Contractor knew of, or should have known of, the deficiency.

400.4.7.9.3 Payment Adjustments

Payment Adjustments for each instance when where the sideslope and backslope does not conform to the requirements herein, shall be \$1,000/occurrence/week or any partial week, for deficiencies located within the clear zone and \$1,000/occurrence/month or any partial month, for other deficiencies.

400.4.8 TRAFFIC CONTROL DEVICES - OPERATION AND PERFORMANCE REQUIREMENTS

400.4.8.1 Signs

Signs shall be maintained such that they function as designed. The Contractor shall undertake the necessary maintenance to ensure that the desired message is available to motorists at all times. The following shall apply:

- Signing which does not function as designed shall be adjusted, relocated, and/or supplemented to meet the intended function. This includes ensuring signs are not obscured by other signs and do not provide conflicting messages;
- All signs shall be maintained to the physical size, materials, and lettering as designed and constructed for the original installation;
- Signs shall be kept clean and legible at all times;
- Signs shall have an acceptable level of retroreflectivity. Generally, acceptable retroreflectivity can be determined by visual examination of the sign under night-time driving conditions. Signs that exhibit reduced or blotchy retroreflectivity in excess of 25% of the sign area shall be considered to have unacceptable retroreflectivity. Sign reflectivity shall meet the requirements of ASTM D4956;
- Measurement of retroreflectivity will be determined in accordance with ASTM E1710 using a portable retroreflectometer;
- Signs shall be replaced if sign-sheeting material delaminates from the sign blank;
- Sign posts shall be maintained straight and true and shall not lean more than 25 mm in 1 m in any direction;
- Signs shall be kept level, within 25 mm in 1 m, and properly orientated for the travelling public;
- All post replacement of mounted signs shall be the same type as the original installation;
- Galvanized or painted posts shall have the coating maintained such that no corrosion is visible;
- The maintenance of breakaway bases shall be conducted to meet the requirements of the design specifications;

- Signs or billboards containing advertising or for any commercial purpose are not permitted. The Contractor is responsible for the removal of all such signs/billboards; and
- The Contractor shall remove any non-conforming signs or any unauthorized signs from the Road Right of Way.

400.4.8.1.1 Measuring for Compliance

The Contractor shall conduct a regular monitoring program for evaluating the condition of all signs within the New Infrastructure.

400.4.8.1.2 Completing Repairs

The Contractor shall repair/replace any sign that is damaged, stolen, vandalized or which otherwise fails to meet the requirements of this Section 400.4.8, within the following timelines:

- Non-critical regulatory signs shall be repaired/replaced within 48 hours;
- Standard information/directional signs shall be repaired/replaced within 14 days; and
- Non-standard information/directional signs shall be repaired/replaced within 60 calendar days.

For straightening, or otherwise maintaining signs, the work shall be conducted within 21 days, unless the deficiency is such as to affect the effectiveness of the sign.

Unauthorized signs shall be removed within one day.

These time lines apply to the time elapsed from when the Contractor knew of, or should have known of, the deficiency with respect to any specification requirement in Section 400.4.8.

400.4.8.1.3 Payment Adjustments

Payment Adjustments shall be assessed against the Contractor for failing to maintain, repair/replace signs within the stipulated time as follows:

- General maintenance - \$100/sign/week for any whole or partial week the sign remains in need of maintenance;
- Repair or replacement of non-critical regulatory signs - \$1,000/sign/day, or any partial day, until rectified;
- Repair or replacement of information signs < 1 m² or failure to remove an unauthorized sign - \$100/sign/day or any partial day, until rectified; and

- Repair or replacement of information signs > 1 m² - \$250/sign/day or any partial day, until rectified.

400.4.8.2 Traffic Signals

Traffic signals shall be maintained as designed and shall be fully operational at all times. The following shall apply:

- Signal lights, including any cross-walk lights or advance warning devices shall be maintained such that all lights function at all times;
- Electronics associated with signal operation and timing, etc. shall be maintained such that all signal operations are functioning at all times;
- Power supplies for signal installations shall be protected, maintained and serviced as required to ensure an uninterrupted power supply is available for signal operation at all times;
- Signal poles shall be maintained straight and true and shall not lean more than 10 mm in 1 m in any direction;
- Poles, control cabinets and other signal hardware shall be maintained such that no corrosion is visible and that corrosion does not affect the structural and operational integrity of any elements; and
- All repairs shall comply with the original design requirements.

400.4.8.2.1 Measuring for Compliance

The Contractor shall conduct a regular monitoring program for evaluating the condition of all traffic signals within the New Infrastructure.

400.4.8.2.2 Completing Repairs

The Contractor shall repair/replace any signals damaged, stolen, vandalized or which otherwise fail to meet the requirements of this Section 400.4.8.2, within the timelines as follows:

- For non-functioning signals, signing shall be installed immediately to direct traffic until signal function is restored;
- For all signals, repairs shall be undertaken immediately to restore the full functionality of the signal;
- For straightening signal standards, or otherwise maintaining signals, the work shall be conducted within 30 days, unless the deficiency is such as to affect the operation of the signal; and
- Corrosion remediation shall be carried out within 30 days.

A non-functional signal is defined as a signal location at which signal control is not available on any signal head for traffic from one (or more) directions.

The time lines apply to the time elapsed from when the Contractor knew of, or should have known of, the deficiency.

400.4.8.2.3 Payment Adjustments

Any period of non-operation, for any reason whatsoever, including power failure under the Contractor's control, shall result in a Payment Adjustment, following the expiration of the specified time period for completing the specific repair, in accordance with the following:

- First occurrence of a non-functioning signal location - \$500/hour or any partial hour, until rectified;
- First occurrence of non-functioning bulb or colour display (maximum of one at a signal location) - \$100/day or any partial day, until rectified;
- First occurrence of non-functioning bulb or colour display (2 to 4 non-functioning lights or colour displays (provided no non-functioning two bulbs or colour display of the same type affects traffic in any single direction)) - \$200/day or any partial day, until rectified;
- First occurrence of mis-aligned signal pole - \$100/day or any partial day, until rectified; and
- Each occurrence to remediate corrosion within the specified time - \$100/occurrence/month or any partial month, until rectified.

Payment Adjustments for further occurrences of non-compliance following the first occurrence shall be twice the value shown above. In this section, "occurrence" refers to an occurrence anywhere on the Infrastructure.

The number of occurrences of non-compliance shall be determined for a consecutive 12 month period.

400.4.8.3 Pavement Markings

Pavement markings shall be maintained such that they function as designed. Pavement markings shall be maintained to achieve the following general objectives:

- To provide positive lane delineation for the safe and orderly movement of traffic on the New Infrastructure.
- To convey information to a vehicle operator without diverting the driver's attention.
- To complement regulations or warnings by other devices such as traffic signals or signs.

All non-illuminated sections of roadway shall have markings with a minimum retroreflectivity of 100 mcd/lux/m² based on a minimum of five discreet measurements in

any area of concern. All markings shall be maintained in a manner such that they are in proper repair, fully visible, complete and intact. Specifically but not exclusively, the Contractor shall ensure that:

- Dirt or debris which obscures the markings is removed;
- Breaks in markings caused by repair work, accident or any other reason, are reinstated;
- Temporary markings for scheduled resurfacing are installed;
- Markings comply with all design requirements and the following tolerances:
 - Nominal 100 mm wide lines shall be applied to a tolerance of 100 mm to 110 mm;
 - Nominal 200 mm line widths shall be applied to a tolerance of 200 to 210 mm;
 - All direction dividing, lane dividing or continuity lines shall not exceed a maximum dimensional length deviation of +/- 100 mm for a specified 6.0 m or 3.0 m length of space; and
 - All markings shall be applied at the proper location in accordance with the designed markings and in no case shall vary from the design location by more than 100 mm;
- All non-conforming markings are obliterated from the roadway; and
- Painted pavement markings shall exhibit:
 - No excessive (more than 10%) overspray;
 - No splattering of paint;
 - Clean definitive edges;
 - No more than five tracks per km;
 - Uniform distribution of glass beads across the line; and
 - Uniform thickness.

400.4.8.3.1 Measuring for Compliance

The Contractor shall inspect the New Infrastructure on a continual basis and will identify deficiencies related to general maintenance requirements. Deficient lines or markings will be measured and rounded up to the nearest full kilometre for the Payment Adjustment. Measurement of retroreflectivity of the pavement markings will be determined in accordance with ASTM Standard Test Method E1710 using a portable retroreflectometer.

400.4.8.3.2 Completing Repairs

Temporary markings following repair work, scheduled maintenance or rehabilitation shall be installed the same day as the work is performed.

Permanent markings are required to be installed within seven days of temporary markings being installed.

Incorrect or confusing markings shall be removed immediately. This may involve remedial measures pending scheduling of permanent removal.

400.4.8.3.3 Payment Adjustments

If temporary markings are not installed within the time period specified, Payment Adjustments in the amount of \$5,000 per line/marking per km or any partial km, per day or any partial day, shall be assessed until the temporary markings are installed.

If the permanent markings to replace temporary markings are not installed to the required standard within the stipulated time period, Payment Adjustments in the amount of \$100 per line/marking per km or any partial km, per day or any partial day, shall be assessed to the Contractor until the repairs are made.

If non-compliant markings are not re-installed to the required standard within the stipulated time period, Payment Adjustments of \$100 per marking/day or any partial day, shall be assessed until the markings are re-installed.

If incorrect or confusing markings are not removed within seven days, Payment Adjustments in the amount of \$100/marking/day or any partial day, shall be assessed to the Contractor until the repairs are made.

400.4.9 ROAD TRAFFIC NOISE MITIGATION

Requirements for road traffic noise mitigation are described in the Section 200 (Project Specifics). If the AADT exceeds 75,000 vpd on either the New Infrastructure or the Existing Infrastructure, the Contractor will be relieved of the responsibility for further road traffic noise mitigation for those sections of Stoney Trail.

400.4.9.1 Measuring For Compliance

The Contractor shall measure noise levels to confirm noise levels are in compliance with Section 200 (Project Specifics). Noise measurements will generally be made in response to public complaints but will not be required more than once in any 12 month period.

400.4.9.2 Completing Repairs

When measurements indicate noise exceeds the limiting noise level, the Contractor shall undertake remedial action to either reduce the noise levels generated or to effectively screen the areas as required to reduce noise levels. Any proposed screening devices shall require the prior written approval of the Department. The Contractor shall effect repairs required to result in compliance with the limiting noise level within 180 days of becoming aware of the non-compliance.

400.4.9.3 Payment Adjustments

Subject to the 2nd sentence of Section 400.4.9 (Road Traffic Noise Mitigation), if the Contractor fails to implement repairs to attain compliance within the stipulated time period, the Contractor shall be assessed a Payment Adjustment as set out below until repaired.

For the first 180 days, the Payment Adjustment shall be \$50,000/30 day period or any partial 30 day period, for each km of roadway or any partial km, which exceeds the noise level.

Following the 180 day period, a Payment Adjustment of \$100,000/30 day period or any partial 30 day period, for each km of roadway or any partial km, shall be assessed.

If within 360 days of the time period stipulated for completing repairs, the Contractor has not completed repairs to result in compliance, the Department may undertake the construction of sound attenuating works and deduct the costs, plus a 25% administration fee, from Payments to be made to the Contractor.

The Contractor's responsibility for noise mitigation applies to and includes mainline AADT volumes of 75,000. AADT volumes shall be determined in accordance with Section 200.3.1 (Traffic Volume Payment Adjustments).

400.5 BRIDGE STRUCTURES

400.5.1 OPERATIONS

400.5.1.1 General

During the Contractor's regularly scheduled inspections of the roadway and appurtenances as specified in Section 400.2 (Inspection, Emergency and Routine Maintenance Requirements), the Contractor shall pay special attention to the condition, functionality and safe operation of the bridge structures. The Contractor shall ensure that qualified personnel carry out the regularly scheduled inspections. Any deficiencies that pose an imminent danger to the travelling public shall be addressed immediately.

In addition, regular scheduled bridge inspections as outlined in Section 400.5.1.3 (Performance Compliance Inspection and Testing) shall be completed by the Contractor to measure and determine compliance with the bridge structure performance requirements identified in Section 400.5.3 (Performance Requirements). Appropriate preventative maintenance, repair and rehabilitation actions are expected to be required during the Operating Period. The Contractor is expected to take appropriate action to address identified deficiencies within specified time periods to ensure the long-term durability and serviceability of the bridge structures.

400.5.1.2 Utility Accommodation

The Contractor shall accommodate utilities on the bridge structures when requested by the Department. All costs associated with the installation, maintenance and operation of the utilities shall be the responsibility of the utility owner.

During the Operating Period, the utility line may need to be removed or relocated to facilitate major maintenance, rehabilitation, replacement or closure of a bridge structure. Relocation or removal of the utility line, including all associated costs, shall be borne by the owner of the utility.

In the event that a utility line is no longer required, the utility owner shall advise the Department and the Contractor and arrange for the line to be removed and, when applicable, for the structure to be restored to the condition commensurate with that prior to the installation of the line.

400.5.1.3 Performance Compliance Inspection and Testing

400.5.1.3.1 Inspections and Testing

All bridge structures included under New Infrastructure will be considered a component of the provincial bridge structure inventory and as such shall be subject to at least the same level of inspection as are all other bridge structures on the Provincial highway system.

The Contractor or its designated representative shall complete bridge inspection and testing of the bridge structures to measure and determine compliance to the performance requirements. The compliance inspection and testing shall be based on the Department's existing *Bridge Inspection and Maintenance (BIM) System*.

The BIM system consists of two levels of inspection. Level 1 inspections are routine inspections that are carried out on a regular inspection cycle and are primarily a visual inspection carried out without the use of specialized equipment for testing or for access. Level 2 inspections will also be carried out on a specified interval or on a one-time site-specific basis. Using specialized equipment and expertise, the Level 2 inspections gather detailed and quantified information and data on a particular bridge structure or bridge element.

400.5.1.3.2 Routine Level 1 Inspections

The Contractor shall complete routine Level 1 inspections in accordance with the Department's current *Bridge Inspection and Maintenance (BIM) System* to confirm that the performance requirements in Section 400.5.3 (Performance Requirements) are being met. Only qualified and experienced bridge inspectors that have a current Class A certification under the Department's BIM system shall complete the inspections.

The routine Level 1 bridge inspections will be completed at the prescribed cycle as follows:

- Initial inspection within 30 days of Construction Completion; and
- Every 21 months after the initial inspection.

The routine inspection cycle may be shortened if deemed necessary by the inspector due to condition, functionality, use of the bridge structures or any other reason.

The Contractor shall complete each routine Level 1 inspection within the time period of one month prior to the originally scheduled date of the routine Level 1 inspection to one month following the originally scheduled date of the routine Level 1 inspection.

400.5.1.3.3 Specialized Level 2 Inspections

The Department currently carries out a number of specialized Level 2 inspections including concrete deck, copper sulphate electrode (“CSE”) or half-cell testing, chloride ion content testing, ultrasonic inspection of steel elements, scour survey, steel culvert barrel measurement, timber coring, concrete girder, paint system and vertical clearance measurement.

For the Department’s standard deck protection system as identified in Section 300.5.2.7 (Bridge Structures – Design Criteria – Durability) the Contractor shall complete the following specialized Level 2 inspections to determine the condition of the concrete bridge decks:

- Year 15 Concrete deck inspection, CSE testing, Chloride ion content testing
- Year 20 Concrete deck inspection, CSE testing, Chloride ion content testing
- Year 25 Concrete deck inspection, CSE testing, Chloride ion content testing

For alternative deck protection systems the Contractor shall identify the performance criteria and the testing proposed for determining if the performance of the concrete bridge decks at Years 15, 20 and 25 meets the performance criteria.

Only qualified and experienced bridge inspectors that have a current Class A certification under the Department’s BIM system shall complete the inspections.

The specialized Level 2 inspection and testing, except for the submission of inspection results, shall be completed between May 15 and September 15 of the testing year specified.

400.5.1.3.4 Inspection and Testing Notification

The Contractor shall notify the Department a minimum of two weeks in advance of the scheduled inspection and testing date and time. The Department may elect to have a representative on site during the Contractor’s scheduled inspection and testing. The Department also reserves the right to complete inspection or testing concurrently with the Contractor’s scheduled inspection and testing or at any other time. In the event the Department elects to complete inspection and testing concurrently with the Contractor’s scheduled inspection and testing, the Contractor shall provide the required traffic accommodation and assistance and cooperation.

The Department will use in-house or external engineering consultants to complete the inspection and testing on their behalf. Only qualified and experienced bridge inspectors that have a current Class A certification under the Department’s BIM system will perform the Department’s inspection and testing work.

400.5.1.3.5 Inspection Reporting

Within 30 days of the completion of a routine Level 1 bridge inspection and within 90 days of the completion of a specialized Level 2 bridge inspection and testing, the Contractor shall provide the results of the inspection and testing to the Department. In addition to the inspection and testing results, the Contractor shall submit a report identifying any components or elements found to be non-compliant with the performance requirements in Section 400.5.3 (Performance Requirements). Each identified deficiency will be categorized as structural and operation or standard maintenance in accordance with the requirements of Section 400.5.2 (Bridge Maintenance and Operations) along with the specified time period for commencement or completion of repair and/or remediation actions.

400.5.1.3.6 Payment Adjustments

In the event the Contractor fails to complete the scheduled inspection and testing requirements, including the submission of inspection results to the Department, the Department shall assess the following Payment Adjustments for late submission of inspection results:

- \$10,000/bridge/month or any partial month, for routine Level 1 inspections until submitted;
- \$20,000/bridge/year or any partial year, specialized Level 2 inspections until submitted.

400.5.1.3.7 Traffic Accommodation

The Contractor is expected to generally perform inspections and testing during non-peak traffic periods and on dates that cause a minimum of inconvenience to the travelling public.

The bridge inspection and testing may require inspectors and workers to be on or in close proximity to the roadway, making traffic accommodation necessary. The Contractor shall provide all necessary temporary signing and traffic accommodation for the duration of the inspection and testing at its own cost.

Lane Closure Payment Adjustments (see Section 400.1.6) shall be charged during inspection and testing carried out by the Contractor but not for testing and inspection carried out by the Department.

400.5.1.3.8 Measurement and Determination

The Department has made every effort to develop and use measurable and quantifiable performance requirements for the bridge structure elements. The BIM system minimizes the subjective nature of these evaluations through formal guidelines and extensive training and certification of inspection personnel.

400.5.2 BRIDGE MAINTENANCE AND OPERATIONS

400.5.2.1 General

The Contractor shall be required to maintain the bridge structures in a safe and effective operating condition at all times during the Operating Period. This will require preventative maintenance, standard maintenance and periodic rehabilitation actions during the Operating Period.

The quality and standard of the maintenance and rehabilitation actions are expected to be appropriate to ensure the 75 year service life of the bridge structures.

400.5.2.2 Structural and Operational

Structural and operational deficiencies are deficiencies that compromise public safety and must be repaired prior to the 20 months allowed for standard maintenance repairs. An inexhaustive list of some structural and operational deficiencies are as follows:

- Repair of misalignment or cracking to steel girders caused by collision damage, overloads or other causes;
- Repair of excessive cracking, spalling or reinforcement damage to concrete girders caused by collision damage, overloads or other causes;
- Repair of potholes in the bridge deck;
- Repair of deck joint components protruding above the riding surface and causing a hazard to traffic;
- Repair of misalignment, cracking or rupture of bridgerail or guardrail components caused by collision damage or other causes;
- Repair of culverts with deformations exceeding those allowed by the performance requirements;
- Repair of longitudinal cracked seams in culverts; and
- Repair of misalignment and cracking in sign structure support components.

The Contractor shall commence work to rectify a structural or operational deficiency within 60 days of identification.

For some deficiencies that may not be effectively repaired or rectified during inclement weather, the Department at its sole discretion may extend the required time period for commencement of work to 180 days.

400.5.2.3 Standard Maintenance

If the Department agrees that deficiencies do not fall within the category of structural and operational they shall be categorized as standard maintenance. These deficiencies are expected to be non-safety and non-hazard related. The Contractor shall complete work to rectify these deficiencies within 20 months of identification.

400.5.2.4 Preventative Bridge Structures Maintenance

Preventative bridge structures maintenance actions shall include, but not be limited to, annual bridge washings and a regular sealing program for concrete surfaces exposed to de-icing salts.

400.5.2.5 Payment Adjustments

In the event the Contractor fails to meet the specified schedule for satisfactory repair and remediation of identified deficiencies, the Department shall assess the following Payment Adjustments:

400.5.2.5.1 Structural and Operational

In the event the Contractor fails to commence work within 60 days of identification of a structural or operational deficiency, a Payment Adjustment of \$1,000/day or any partial day, per deficiency shall be assessed until the Contractor commences and diligently pursues completion of the work.

For deficiencies where the Department has extended the required time period for commencement of work to 180 days, a Payment Adjustment of \$1,000/day or any partial day, per deficiency if the Contractor fails to commence work within 180 days of being notified of the deficiency and shall be assessed until the Contractor commences and diligently pursues completion of the work.

400.5.2.5.2 Standard Maintenance

In the event the Contractor fails to complete work within 20 months of a standard maintenance deficiency being identified, a Payment Adjustment of \$5,000/month or any partial month, per deficiency shall be assessed until the Contractor completes the work.

400.5.2.5.3 Preventative Bridge Structures Maintenance

In the event the Contractor fails to complete the scheduled preventative bridge structures maintenance, with the exception of annual bridge washings within the year scheduled, a Payment Adjustment of \$5,000/bridge/month or any partial month, shall be assessed until the Contractor completes the work.

In the event the Contractor fails to complete the annual bridge washings by June 1 of the year scheduled, a Payment Adjustment of \$5,000/bridge/month or any partial month, shall be assessed until the Contractor completes the work.

400.5.2.6 Bridge Structure Maintenance and Rehabilitation Requirements

At least two weeks prior to commencement of any bridge structures maintenance actions, the Contractor shall submit detailed design drawings and construction specifications required for the proposed work to the Department for information and review, if applicable.

At least one month prior to commencement of bridge structures rehabilitation actions, the Contractor shall submit detailed design drawings and construction specifications for the proposed work to the Department for information and review.

400.5.2.7 Notification Of Bridge Structure Maintenance and Rehabilitation

The Contractor shall notify the Department a minimum of two weeks in advance of any proposed bridge structure maintenance or rehabilitation actions. The written notification shall outline the type of work proposed, schedule for commencement and completion, hours of work and any lane closures or impacts to the travelling public.

400.5.3 PERFORMANCE REQUIREMENTS

400.5.3.1 General

The individual components and elements of bridge structures shall be in adequate condition and functioning as designed during the Operating Period.

No component or element shall show evidence of any loss in structural strength and shall operate safely and in a manner consistent with the Department's *Bridge Inspection and Maintenance System*.

Notwithstanding the performance requirements stated in Sections 400.5.3.2 (Individual Component Requirements – Bridges), 400.5.3.3 (Individual Component Requirements – Bridge Culverts) and 400.5.3.4 (Individual Component Requirements – Sign Structures) for bridges, bridge culverts and sign structures respectively, all individual components rated three or less under the Department's *Bridge Inspection and Maintenance System* shall be considered to be in non-conformance.

400.5.3.2 Individual Component Requirements - Bridges

400.5.3.2.1 Approach Slab

There shall be a smooth transition on and off the bridge structure from the roadway. A smooth transition is defined as the grade on the approach slab deviating less than 1% from the design grade. Any voids beneath the approach slab shall be filled if the approach slab grade deviates by more than 1% from the theoretical grade.

400.5.3.2.2 Wearing Surface

The wearing surface on bridge structures shall meet the rutting requirements as stated for the roadway in 400.4.4 (Rutting Performance Requirements).

The wearing surface on bridge structures shall meet the skid resistance requirements as stated for the roadway in 400.4.5 (Skid Resistance Requirements).

Asphalt concrete pavement (“ACP”) wearing surfaces on bridge structures shall meet the general pavement maintenance requirements as stated for the roadway in 400.4.6 (General Pavement Maintenance Requirements).

The pavement markings on bridge structures shall meet the pavement lines and message requirements as stated for the roadway in 400.4.8.3 (Pavement Markings).

400.5.3.2.3 Concrete Bridge Decks

Unless noted otherwise, the bridge deck shall not have any physical defects or chemical deterioration.

Concrete bridge decks cast-to-grade shall not have any cracks greater than 0.1 mm in width and a linear measurement of 0.2 m of cracking per square metre of bridge deck area.

The underside of all concrete decks shall be free of stains resulting from deterioration, efflorescence and exudation.

Any cracking on the deck underside shall be limited to a maximum width of 0.3 mm.

The following performance requirements for specialized Level 2 inspections shall be met for the Department’s standard deck protection system as identified in Section 300.5.2.7 (Durability):

Year 15 of the Operating Period

CSE test results showing a minimum of 90% of deck area with readings less negative than -0.300 mV.

Maximum average total chloride content of 0.010, by percent weight, at the top mat of reinforcing or 100 mm depth, whichever is less.

Year 20 of the Operating Period

CSE test results showing a minimum of 85% of deck area with reading less negative than -0.300 mV.

Maximum average total chloride content of 0.015, by percent weight, at the top mat of reinforcing or 100 mm depth, whichever is less.

Year 25 of the Operating Period

CSE test results showing a minimum of 80% of deck area with reading less negative than -0.300 mV.

Maximum average total chloride content of 0.020, by percent weight, at the top mat of reinforcing or 100 mm depth, whichever is less.

Deck testing shall be carried out in accordance with the requirements of the Department's *Level 2 Bridge Inspection Manual*.

The copper sulphate electrode testing is based on the ASTM C876 method with some minor differences. The method for CSE testing is outlined in the Department's BT009-March 98 "*Test Procedure for Evaluating Corrosion of Reinforcing Steel in Bridge Decks*."

Chloride content testing is performed in accordance with the "*Standard Test Method for Chloride Content in Concrete Using the Specific Ion Probe*" as described in SHRP-S-330, Appendix F or "*The Method of Field Determination of Total Chloride Content*" as described in SHRP-S-328, Volume 6 or approved equivalent test method such as Alberta Transportation Test Method TLT 520.

For alternative deck protection systems the Contractor shall identify the performance criteria to be met by the concrete bridge decks at Years 15, 20 and 25.

400.5.3.2.4 Curbs, Barriers and Medians

Unless noted otherwise, there shall be no physical defects or chemical deterioration. Any scaling shall be limited to light scaling over a maximum surface area of 10% of the face and top of the curb, barrier or median.

Cracking shall be limited to a maximum width of 0.3 mm occurring at a maximum frequency of one crack every 2 m over the length of the bridge structure.

There shall be no exposure of utility voids or other formed voids.

Differential movement in the horizontal or vertical direction shall be limited to 6 mm.

Expansion joints shall be free for movement and not cracked or spalled due to insufficient travel.

400.5.3.2.5 Bridge and Pedestrian Rails

Elements shall be free of collision damage, horizontal and vertical misalignment, improper guardrail laps, loose connections and missing nuts and bolts.

Steel components shall be free of deformation, cracks and corrosion.

Anchor bolts shall have proper alignment and firm anchorage.

There shall be no physical defects or chemical deterioration in the grout pads.

400.5.3.2.6 Deck Joints

Deck joints shall be vertically aligned, properly anchored, have freedom of movement and not have variation in the gap opening more than 10% along the length of the deck joint. There shall be no missing or loose bolts.

All deck joints shall capture and manage deck drainage such that it does not come into contact with the concrete and steel surfaces of other bridge elements.

For finger joints, the fingers shall sit level, have no cracks and the trough system under the joint shall function without signs of leakage or debris accumulation.

For gland type joints, there shall be no signs of leakage or holes or damage to the seal or leakage around the joint.

Steel components shall be free of deformation, cracks and corrosion.

400.5.3.2.7 Bridge Deck Drainage Systems

Potholes or the build up of gravel or debris shall not cause any ponding on the bridge deck or impede the flow of water away from the bridge deck.

Deck drains and pipes shall not be clogged with debris.

Down spouts shall be low enough to prevent splashing of water on superstructure and substructure elements.

There shall be no ponding of water along the shoulders or in the driving lanes.

For grade separations, the location of drains shall not create ponding water or an icing hazard on the roadway below.

400.5.3.2.8 Concrete Girders

Unless noted otherwise prestressed concrete girders shall not have any physical defects or chemical deterioration or staining.

Any cracking in prestressed concrete girders shall be limited to a maximum width of 0.2 mm.

There shall be no signs of damage or deterioration due to impacts or collisions.

400.5.3.2.9 Steel Girders

Steel girders shall be free of harmful corrosion, notches and cracks.

Bolted connections shall be free of deformation, warping and missing, worn, sheared or deformed fasteners.

Web stiffeners shall not have any evidence of buckling.

Girders shall not show any evidence of sags, buckling, bowing or twisting.

All welds shall be free of cracks.

There shall be no signs of damage or deterioration due to impacts or collisions.

400.5.3.2.10 Paint Protection System

The paint protection system applied to the end of steel girders shall be free of signs of cracking, peeling, or chipping of the paint protection system.

400.5.3.2.11 Sidewalks

Sidewalk surfaces shall be smooth but have adequate traction and be free of debris.

Unless noted otherwise, there shall be no physical defects or chemical deterioration. Any scaling shall be limited to light scaling over a maximum surface area of 10% of the sidewalk area.

Any cracking shall be limited to a maximum width of 0.3 mm and a linear measurement of 1 m of cracking per square metre of sidewalk area.

Steel components shall be free of corrosion, notches, cracks, sheared bolts and cracked welds.

400.5.3.2.12 Bearings

Bearings shall be operational and shall be free of all debris that may impede movement.

Expansion bearings shall have available travel relative to temperature without excessive vibrations or movement under traffic.

Coating system on bearings shall be functioning and intact.

Component parts shall have proper alignment, proper contact surfaces and minimum resistance.

Bearing pads and plates shall be in proper position.

There shall be no physical defects or chemical deterioration in the grout pads.

Elastomeric components shall be free of cracks and splits along the edges. Minor bulging of the elastomeric components shall be limited to 10% of the component thickness.

Anchor bolts shall have proper alignment and firm anchorage.

Steel components shall be free of corrosion, notches, cracks, sheared bolts and cracked welds.

400.5.3.2.13 Bearing Seats and Caps

Caps shall not have any rotation or displacement.

Unless noted otherwise for concrete components, there shall be no physical defects or chemical deterioration. Any scaling shall be limited to light scaling over a maximum area of 10%.

Any cracking shall be limited to a maximum width of 0.3 mm and a linear measurement of 1 m of cracking per square metre.

The bottoms of bearing seats shall not be exposed due to soil settlement or other reasons.

Steel components shall be free of corrosion, notches, cracks, sheared bolts and cracked welds.

400.5.3.2.14 Backwalls and Breastwalls

There shall not be any significant loss of material below the backwall or breastwall.

Unless noted otherwise for concrete components, there shall be no physical defects or chemical deterioration. Any scaling shall be limited to light scaling over a maximum surface area of 10%.

Any cracking shall be limited to a maximum width of 0.3 mm and a linear measurement of 1 m of cracking per square metre.

Steel components shall be free of corrosion, notches, cracks, sheared bolts and cracked welds.

400.5.3.2.15 Wingwalls and Retaining Walls

Wingwalls and retaining walls shall have proper vertical and horizontal alignment. The bottoms of these elements shall not be exposed due to soil settlement or other reasons.

Unless noted otherwise for concrete components, there shall be no physical defects or chemical deterioration. Any scaling shall be limited to light scaling over a maximum surface area of 10%.

Any cracking shall be limited to a maximum width of 0.3 mm and a linear measurement of 1 m of cracking per square metre.

Steel components shall be free of corrosion, notches, cracks, sheared bolts and cracked welds.

400.5.3.2.16 Piers

Piers shall not have any evidence of collision damage or damage due to ice or debris.

Visible piles shall not have any evidence of bowing or misalignment due to deterioration, impact, excessive loads or unintended lateral loading.

There shall be no signs of heaving or settlement.

Unless noted otherwise for concrete components, there shall be no physical defects or chemical deterioration. Any scaling shall be limited to light scaling over a maximum surface area of 10%.

Any cracking of concrete components shall be limited to a maximum width of 0.3 mm and a linear measurement of 1 m of cracking per square metre.

Steel components shall be free of corrosion, notches, cracks, sheared bolts and cracked welds.

400.5.3.2.17 Nose Plates

There shall be no missing plate sections or loose connections.

There shall not be loss of section due to corrosion.

Nose plates with significant impact damage shall be repaired or replaced.

400.5.3.2.18 Concrete Finishes

Concrete finishes in visible areas shall not be stained, chipped or peeling.

400.5.3.2.19 Slope Protection for River Crossing

Any settlement of the headslope fill in the vicinity of the abutment shall be limited to 150 mm.

Slope or scour rock riprap protection shall be of the required gradation and quality as specified in the Detailed Designs.

Average rock size and thickness of the rock layer shall be as specified in the Detailed Designs.

For concrete slope protection, gaps between the abutment and the slab shall be limited to 100 mm.

There shall be no crushing of concrete around the pier or bulging at the toe.

Unless noted otherwise there shall be no physical defects or chemical deterioration. Any scaling shall be limited to light scaling over a maximum surface area of 10% of the slope protection.

Any cracking shall be limited to a maximum width of 0.3 mm and a linear measurement of 1 m of cracking per square metre of the slope protection area.

400.5.3.2.20 Slope Protection for Grade Separation

Any settlement of the headslope fill in the vicinity of the abutment shall be limited to 150 mm.

For concrete slope protection, gaps between the abutment and the slab shall be limited to 100 mm.

There shall be no crushing of concrete around the pier or bulging at the toe.

Unless noted otherwise there shall be no physical defects or chemical deterioration. Any scaling shall be limited to light scaling over a maximum surface area of 10% of the slope protection area.

Any cracking shall be limited to a maximum width of 0.3 mm and a linear measurement of 1 m of cracking per square metre of the slope protection area.

Drainage shall not penetrate below the slab and there shall be no presence of voids below the slab.

400.5.3.2.21 River Training Works

Average rock size, gradation and thickness of the rock layer shall be as specified in the Detailed Designs.

There shall not be significant scour or erosion around or under the training works.

Unless noted otherwise for concrete components, there shall be no physical defects or chemical deterioration. Any scaling shall be limited to light scaling over a maximum surface area of 10%.

Any cracking shall be limited to a maximum width of 0.3 mm and a linear measurement of 1 m of cracking per square metre.

400.5.3.2.22 Other Bridge Structure Elements

Other bridge structure elements not listed in these requirements shall be in adequate condition and functioning as designed throughout the Operating Period.

400.5.3.3 Individual Component Requirements – Bridge Culverts

400.5.3.3.1 Embankments

Embankments shall not show any signs of instability such as slumping, excessive settlement, or cracking.

Embankments shall not show any signs of erosion such as gullying or erosion or scour along the toe of the sideslope.

The slope of the embankment shall be as specified in the Detailed Designs.

400.5.3.3.2 Headwalls and Collars

Headwalls and collars shall not have excessive settlement or rotation and must be securely connected to the barrel or bevel section.

Headwalls and collars shall not show any signs of piping, scour or erosion.

Unless noted otherwise for concrete components, there shall be no physical defects or chemical deterioration. Any scaling shall be limited to light scaling over a maximum surface area of 10%.

Any cracking shall be limited to a maximum width of 0.3 mm and a linear measurement of 1 m of cracking per square metre.

Steel components shall not have excessive corrosion, loss of section or loose connections.

400.5.3.3.3 Wingwalls

Any gap or void between the wingwall and the barrel section shall be limited to a maximum of 75 mm. There shall not be any loss of fill material.

Wingwalls shall have proper vertical alignment and be securely connected to the headwall, if applicable.

Unless noted otherwise for concrete components, there shall be no physical defects or chemical deterioration. Any scaling shall be limited to light scaling over a maximum surface area of 10%.

Any cracking shall be limited to a maximum width of 0.3 mm and a linear measurement of 1 m of cracking per square metre.

Steel components shall not have excessive corrosion, loss of section or loose connections.

400.5.3.3.4 Cutoff Walls

Cutoff walls shall be securely connected to the culvert invert.

There shall be no signs of undermining, piping or uplift.

400.5.3.3.5 Bevel Ends

For flexible culverts, any deformation (dimensional change) is limited to within 7% of the design or as-constructed dimensions.

Unless noted otherwise for concrete culverts, there shall be no physical defects or chemical deterioration. Any scaling shall be limited to light scaling over a maximum surface area of 10%.

Any cracking shall be limited to a maximum width of 0.3 mm and a linear measurement of 1 m of cracking per square metre.

400.5.3.3.6 Roofs

For flexible culverts, any deformation (dimensional change) is limited to within 7% of the design or as-constructed dimensions.

Unless noted otherwise for concrete culverts, there shall be no physical defects or chemical deterioration. Any scaling shall be limited to light scaling over a maximum surface area of 10%.

Any cracking shall be limited to a maximum width of 0.3 mm and a linear measurement of 1 m of cracking per square metre.

400.5.3.3.7 Sidewalls

For flexible culverts, any deformation (dimensional change) is limited to within 7% of the design or as-constructed dimensions.

Unless noted otherwise for concrete culverts, there shall be no physical defects or chemical deterioration. Any scaling shall be limited to light scaling over a maximum surface area of 10%.

Any cracking shall be limited to a maximum width of 0.3 mm and a linear measurement of 1 m of cracking per square metre.

400.5.3.3.8 Floors

For flexible culverts, any heaving (dimensional change) is limited to within 7% of the design or as-constructed dimensions.

Unless noted otherwise for concrete culverts, there shall be no physical defects or chemical deterioration. Any scaling shall be limited to light scaling over a maximum surface area of 10%.

Any cracking shall be limited to a maximum width of 0.3 mm and a linear measurement of 1 m of cracking per square metre.

400.5.3.3.9 Circumferential Seams

Circumferential seams shall not be misaligned between adjoining sections.

There shall be no evidence of infiltration of backfill material caused by improper connections or separation of adjoining sections.

Circumferential seams shall not have any cracks.

400.5.3.3.10 Longitudinal Seams

Longitudinal seams shall not have any cracks.

Longitudinal seams shall not have any signs of bolt tipping, distortion, cusping, improper nesting or signs of corrosion.

400.5.3.3.11 Coatings

Steel culvert material may have some superficial rust but no pitting or loss of section.

400.5.3.3.12 Fish Passage Enhancement Features

Concrete, steel or rock boulders used for baffles or other fish enhancement features shall be located as specified in the Detailed Designs.

Unless noted otherwise for concrete components, there shall be no physical defects or chemical deterioration. Any scaling shall be limited to light scaling over a maximum surface area of 10%.

Any cracking shall be limited to a maximum width of 0.3 mm and a linear measurement of 1 m of cracking per square metre.

Steel material may have some superficial rust but no pitting or loss of section.

400.5.3.3.13 Waterway Adequacy

There shall be no reduction in the culvert opening of more than 35% due to debris accumulation, gravel or siltation.

400.5.3.3.14 Slope Protection

Slope or scour protection shall be of the required gradation and quality, as specified in the Detailed Designs.

Average rock size, gradation and thickness of the rock layer shall be as specified in the Detailed Designs.

400.5.3.3.15 River Training Works

Average rock size, gradation and thickness of the rock layer shall be as specified in the Detailed Designs.

There shall not be significant scour or erosion around or under the training works.

Unless noted otherwise for concrete components, there shall be no physical defects or chemical deterioration. Any scaling shall be limited to light scaling over a maximum surface area of 10%.

Any cracking shall be limited to a maximum width of 0.3 mm and a linear measurement of 1 m of cracking per square metre.

400.5.3.3.16 Other Bridge Culvert Structure Elements

Other bridge culvert structure elements not listed in these requirements shall be in adequate condition and functioning as designed throughout the Operating Period.

400.5.3.4 Individual Component Requirements - Sign Structures

400.5.3.4.1 Pedestal

Unless noted otherwise for concrete components, there shall be no physical defects or chemical deterioration. Any scaling shall be limited to light scaling over a maximum surface area of 10%.

Any cracking shall be limited to a maximum width of 0.3 mm and a linear measurement of 1 m of cracking per square metre.

400.5.3.4.2 Column

Columns shall be properly aligned with no bends, bows or kinks.

Steel components shall be free of corrosion, notches, cracks, sheared or loose bolts and cracked welds.

400.5.3.4.3 Connections/Bearings

There shall be no missing anchor nuts and all nuts shall be fully torqued.

Anchor bolts shall have proper alignment and firm anchorage.

There shall be no physical defects or chemical deterioration in the grout pads.

All concrete in the area of the connections shall be sound.

Welds and connections shall be free of cracks and defects.

400.5.3.4.4 Superstructure Elements

The superstructure is defined as that portion of the sign structure that is attached to the support columns and spans between the columns.

Steel elements shall not show any evidence of sags, buckling, bowing or twisting.

Bolted connections shall be free of deformation, warping, and missing, loose, worn, sheared or deformed fasteners.

Steel elements shall be free of corrosion, notches and cracks.

All welds shall be free of cracks.

400.5.3.4.5 Coatings

Coatings shall be intact and effective in preventing corrosion and loss of section.

There shall be no rusting, scaling, peeling, blistering, discolouration or other defects.

400.5.3.4.6 Other Sign Structure Elements

Other sign structure elements not listed in these requirements shall be in adequate condition and functioning as designed throughout the Operating Period.

500.0 OPERATIONS - EXISTING INFRASTRUCTURE

500.1 OPERATIONS - GENERAL

This Section 500.0 covers the operations and maintenance requirements applicable to roadways and bridge structures in the Existing Infrastructure.

500.1.1 RESPONSIBILITY FOR OPERATIONS

The Contractor is responsible for the supply of all management, supervision, professional and technical services, quality control and assurance, labour, materials, utilities and equipment for performing all of the duties and obligations to operate and maintain the Existing Infrastructure during the Operating Period.

The Contractor is responsible for safe and efficient site traffic accommodation during the Operating Period.

The operational and performance requirements described in the Technical Requirements represent the requirements that shall be met throughout the Operating Period. The Contractor shall measure roadway and bridge structure conditions and assure compliance to the operational and performance requirements which are the Contractor's responsibility to maintain throughout the length of the Operating Period. Where specific operational and performance requirements are not given, the Contractor is expected to operate and maintain roadway elements and bridge structures to a standard of safety, effectiveness and operation equal to, or better than, what is currently being provided on other roadway systems of similar age and type on the Provincial highway system.

500.1.2 MAINTENANCE AND REHABILITATION REQUIREMENTS

The requirements to be met in the maintenance of the Existing Infrastructure during the Operating Period shall conform to the requirements of the Contractor's Operations and Maintenance Plan (Section 100.2.9).

The Contractor is responsible for reclaiming all areas of the Road Right of Way and/or stormwater management facilities that have been disturbed during the Operating Period and shall obtain any required Reclamation Certificates related to these activities within 12 months of completing the reclamation activity.

500.1.3 COMPLIANCE WITH PERFORMANCE REQUIREMENTS

During the Operating Period, the Contractor shall complete such work as required to achieve full compliance to any performance requirements which are the Contractor's responsibility to maintain.

In addition to the Contractor's regular inspection and measurements, the Department may undertake reviews and measurements of the Existing Infrastructure at any time and will advise the Contractor of non-compliance.

Where Payment Adjustments are described relative to a kilometre section of the roadway, the kilometre will be a continuous section of a single lane. Neither the requirement nor the Payment Adjustments will be pro-rated based on a partial kilometre length, but will be calculated for the next highest full kilometre length. Crossroads, and individual ramps or loops will be considered as discrete sections and treated as one kilometre regardless of the actual length. Where Payment Adjustments are described relative to a period of time or a portion thereof, the Payment Adjustment shall not be prorated but shall be applied in full even if only a portion of the specified period of time has elapsed.

500.1.3.1 Alternative Inspection and Testing Methods

During the Operating Period, new technological developments may result in alternative inspection and testing methods and techniques that are more accurate, effective or economical. Mutually agreeable alternative inspection and testing methods and techniques may be introduced during the Operating Period. These new testing methods and techniques may also require new mutually agreeable performance requirements that are consistent with the intent of existing performance requirements.

500.1.4 APPEAL OF DEPARTMENT MEASUREMENTS

In any case where Department measurements have concluded that a deficiency exists, the Contractor may appeal within 30 days, the results of any measurement. Measurements made by the Contractor, using methods and equipment of equal or better accuracy to the Department's specified methods, which indicate the appealed component is not deficient, will be the only cause accepted for allowing an appeal.

The Department and the Contractor will mutually select an independent third party to undertake the appeal measurement(s).

The appeal measurements will be arranged for and paid by the Department and the new measurements shall be binding on the Contractor and the Department and shall not be subject to the Dispute Resolution Procedure. Notwithstanding the foregoing, the Department may, at its sole discretion, elect to accept the measurements submitted by the Contractor as cause for the appeal and forego further measurements.

If the independent third party's measurements verify the deficiency, the Contractor shall be invoiced by the Department, and shall reimburse the Department, for the third party appeal measurement costs plus an additional \$3,500 per appeal.

Any Payment Adjustments supported by the independent third party's measurements shall be upheld. If the independent third party's measurement(s) verify that no deficiency exists, such Payment Adjustments shall be reversed.

500.1.5 IMMINENT DANGER REPAIRS

In instances where the Contractor and/or the Department determines an Imminent Danger (as defined below) exists on the Existing Infrastructure, the Contractor shall have representation within the Road Right of Way, on route to the Imminent Danger, within 30 minutes of becoming aware of, or of the time the Contractor should have been aware of, the Imminent Danger and shall immediately initiate action to protect traffic and the public from the Imminent Danger and shall continue the action until the Imminent Danger is eliminated. This action may take the form of a temporary solution, including the closing of traffic lanes, until permanent repairs are able to be undertaken or the Imminent Danger is removed. If protective action is not undertaken or traffic is not protected from the Imminent Danger immediately, the Department may elect to undertake such action as it determines necessary and the Contractor shall be responsible for the actual cost of the actions which may include the cost of accommodating traffic over, through or around portions of the Infrastructure, if necessary, plus a 25% administration fee. These costs shall be deducted from Payments to be made to the Contractor. In instances where the Contractor fails to meet the above timelines and/or the Department is forced to undertake action to protect any user from an Imminent Danger, the Contractor shall also be assessed a Payment Adjustment of \$10,000/occurrence. The third occurrence in any consecutive 12 month period anywhere on the Infrastructure shall be a potential Termination Event for the purposes of and having the consequences set out in Section 16.8(k) of the DBFO Agreement. The Department shall provide the Contractor with timely notice after the Department has considered it necessary to take action to protect a user from an Imminent Danger situation. The responsibility for the repair of the cause of the Imminent Danger shall be governed by the DBFO Agreement and the other applicable provisions of the Technical Requirements.

For the purposes of this section, "Imminent Danger" refers to a safety hazard that may be encountered by any user of the Infrastructure due to an accident, condition or any other abnormal occurrence on the Infrastructure.

500.1.6 LANE CLOSURE

Under no circumstance, except for an Excepted Lane Closure (as defined below), shall the Contractor close all lanes in either direction during the Operating Period nor implement measures to require or to seek to encourage the public to use an alternative route away from the Infrastructure.

If as a result of an Excepted Lane Closure the need arises to use signs or other measures to require the public to use an alternative route away from the Infrastructure, the

Contractor may effect such measures, provided that the Contractor shall as soon as reasonably practicable advise the Department of such measures and the reasons therefore. The Contractor shall take all reasonable steps to minimize the duration of such measures.

Within 60 days after Construction Completion, the Contractor shall submit to the Department in accordance with the Review Procedure as set out in Schedule 5 (Design and Plan Certification and Review Procedure) to the DBFO Agreement (the “Review Procedure”), a schedule for Lane Closures (as defined below) in respect of the Infrastructure for the first 12 month period after Traffic Availability (the “Agreement Year”) and the next succeeding Agreement Year. No later than January 1 in each Agreement Year after the first Agreement Year the Contractor shall submit to the Department in accordance with the Review Procedure a schedule for Lane Closures in respect of the Infrastructure for the next succeeding Agreement Year. Each schedule of Lane Closures (the “Schedule of Lane Closures”) shall give details of the proposed lanes of Lane Closure, start and end dates for each period of Lane Closure, and the work to be carried out.

The Contractor shall inform the Department of any changes to a Schedule of Lane Closures no later than 60 days prior to the commencement of the applicable Lane Closure.

The Department may raise comments in respect of any period of Lane Closure requested in a Schedule of Lane Closures. In such event, the Department shall notify the Contractor thereof with reasons and shall indicate, in the case of an objection, an appropriate duration for such Lane Closure and in any other case a period when the unacceptable period can be re-scheduled, on the basis that each such re-scheduled period shall be as close as reasonably practicable to the requested period of Lane Closure and of equal duration or, if the Contractor has indicated another period and/or duration that would be preferable to it and that is acceptable to the Department, such other period and/or duration. The Contractor shall thereupon amend the applicable Schedule of Lane Closures accordingly and re-submit the same to the Department in accordance with the Review Procedure.

The Department's approval of Lane Closures shall not be unreasonably withheld or delayed, having regard to the factors set out in the Review Procedure.

The Contractor shall not affect any Lane Closures save:

- in accordance with the Schedule of Lane Closures to which no objection has been made under the Review Procedure; or
- an Excepted Lane Closure.

Notwithstanding that there has been no objection to the Schedule of Lane Closures in accordance with the Review Procedure, the Department may upon 60 days prior written notice require the Contractor to re-schedule a period of Lane Closure if due to a change in circumstances such re-scheduling is necessary.

The Department may not require:

- that such period of Lane Closure be brought forward by more than 60 days from the scheduled date of commencement of such period; or
- that a period of Lane Closure be deferred by more than 60 days from the scheduled date of commencement.

If as a result of an Excepted Lane Closure, the need arises for unscheduled maintenance or repair work requiring Lane Closures, the Contractor shall effect such Lane Closures provided that the Contractor shall as soon as reasonably practicable advise the Department of such closure and the reasons therefore and shall take all reasonable steps to minimize the duration of such Lane Closure.

All Lane Closures shall be subject to the Lane Closure Payment Adjustments except Lane Closures (the “Excepted Lane Closures”) arising, and without being caused by the negligence of the Contractor or those for whom the Contractor is responsible at law, from:

- an emergency, including without limitation clean-up of a motor vehicle accident;
- an order of the police;
- Approved Special Events as defined in Section 200.3.9.2 (Special Events – Partial or Full Closure Events);
- Severe Storm Events (as defined in Section 500.3.1 (Winter Maintenance Operation Requirements – General));
- Repairs to the Existing Infrastructure caused by the Province, its agents and employees and by third party damage provided all reasonable steps are being taken to complete the repairs in accordance with the Contractor’s obligations;
- a direction of the Department or the performing of the Province’s obligations under the DBFO Agreement;
- any Deficiency (as defined in section 6.6 of the DBFO Agreement); or
- any rehabilitation work being carried out or having been carried out by or on behalf of the Department in relation to the Existing Infrastructure.

The Contractor shall provide to the Department such information (including without limitation details of proposed Lane Closures and information about its traffic safety and management measures on the Infrastructure) as may be required for purposes of any information service operated by or on behalf of the Department from time to time.

The Contractor shall operate during the Operating Period a telephone service answered by a knowledgeable person of the Contractor to respond to questions from the public in relation to the Infrastructure.

Subject to the Excepted Lane Closures, for every full or partial hour of Lane Closure (as defined below) occurrence anywhere on the Infrastructure, during the Operating Period,

the Contractor shall be assessed a Payment Adjustment at the applicable lane closure rate. The length of the Lane Closure for determination of Lane Closure Payment Adjustments shall be rounded up to the next higher whole kilometre.

For planned maintenance and rehabilitation activities on two-lane roadways or bridge structures, the Contractor must have at least one lane open to traffic at all times.

For planned maintenance and rehabilitation activities on multi-lane roadways and bridge structures, the Contractor must have at least one lane open to traffic, in each direction, at all times.

Lane Closure Payment Adjustments are as follows:

Type	Timing/Duration	Rate
Peak Hours* - Weekdays	0600 to 0900 and 1530 to 1800 hrs	\$400/hr/lane-km
Day – Weekdays	0900 to 1530 hrs	\$150/hr/lane-km
Day - Weekends and Statutory Holidays	0600 to 1800 hrs	\$150/hr/lane-km
Evening	1800 to 2200 hrs	\$100/hr/lane-km
Night	2200 to 0600 hrs	No Charge

* A Lane Closure for planned operational purposes may not be started during Peak Hours.

A Lane Closure is defined as:

- Any partial or complete closure of a traffic lane; or
- Any reduction of posted speed to less than 75% of the normal posted speed prior to construction impacting any through lane, merge lane or ramp, collector-distributor (C-D) road, turn lane, crossroad, bridge structure, detour or other road forming a part of or connected to the Infrastructure.

Conclusion of Lane Closure is defined as:

- Continuous, smooth, paved intact travel surface;
- Traffic control removed and traffic fully restored; and
- Cause of closure has been removed and all safety requirements have been satisfied.

Also reference Section 500.5.3.2 (Traffic Accommodation).

500.2 INSPECTION, EMERGENCY AND ROUTINE MAINTENANCE REQUIREMENTS

500.2.1 ROADWAY INSPECTIONS

The Contractor's Operation and Maintenance Plan (Section 100.2.9) shall include details on how roadway inspections will be carried out and shall as a minimum, meet the following requirements.

The Contractor shall:

- Inspect the roadway at a minimum frequency of every two hours between 6:30 a.m. and 6:30 p.m., Monday to Friday with the exception of non-Business Days, and every four hours between 6:30 p.m. and 6:30 a.m., Monday to Friday with the exception of non-Business Days;
- Inspect the roadway a minimum of once every four hours (24 hours per day) on days other than Business Days;
- Observe road conditions, repair requirements, snow or weather issues, icing conditions on bridge decks, and sign conditions for each inspection; and
- Confirm the retroreflectivity of signs visually during dark (night time conditions) at least once every two months. Signs that are reasonably considered to be deficient shall be tested within 30 days of the visual inspection.

The Contractor shall provide sufficient resources to patrol the roadway, to observe, react to and report all circumstances or conditions affecting the travelling public or the future repair of the roadway or appurtenances. The Contractor shall investigate reports of adverse conditions from members of the public, regulatory agencies, police authorities or the Department, and perform the immediate repair of all hazardous conditions in accordance with Section 500.1.5 (Imminent Danger) and Section 500.2.2 (Emergency Maintenance).

500.2.1.1 Routine Observations

During the performance of roadway inspections, emergency maintenance, routine maintenance or at any other time the Contractor's personnel are travelling on the roadway, such personnel shall observe conditions of the roadway surface, appurtenances, and Road Right of Way for the purpose of identifying any deficiencies and scheduling such work as required to maintain compliance to the Technical Requirements.

Items of work which would typically be identified during routine observations include but are not limited to the following:

- Damaged signs;
- Drainage problems including blockages, erosion or lack of capacity of ditches, culverts and drainage grates, particularly during spring thaw and run-off. The Contractor shall make interim repairs in these areas when possible;
- Any required cleaning, litter removal or snow removal;
- Damage to structures of appurtenances;
- Roadside or median barriers which have been damaged or moved from the original position, or any other condition that prevents, or reduces the effectiveness of the barrier from performing its intended function;
- Graffiti;
- Burned out lights on the roadway lighting systems;
- Non-functioning, malfunctioning or burned out lights on traffic control lighting systems; and
- Condition of bridge structure components, e.g. bridge rail, bridge deck and bridge deck joints.

500.2.1.2 Daily Road Reports

As part of normal winter duties or as otherwise required, the Contractor shall provide daily road reports in the Department's standard format to the Alberta Motor Association by 0600 hours. These reports shall detail driving conditions on the Existing Infrastructure and shall be updated as required, so that the travelling public is kept current with changing roadway or weather conditions. The Contractor shall provide the Department with a copy of all reports issued.

500.2.2 EMERGENCY MAINTENANCE

Any work identified which falls under the category of emergency maintenance or otherwise results in an unsafe condition shall be immediately addressed by the Contractor and, subject to the DBFO Agreement and the other applicable provisions of the Technical Requirements, at the Contractor's cost.

Emergency maintenance activities, requiring the Contractor's immediate response by having representation within the Road Right of Way, on route to the emergency, within 30 minutes of becoming aware of, or of the time the Contractor should have become aware of, include but are not limited to, the following:

- Repairing or replacing critical regulatory signs (STOP and YIELD) or performing temporary repairs of signs;
- Removing from the roadway surface, roadkill and debris of a size or type that may create a hazard;
- Report all incidences or roadkill to the appropriate authorities;

- If an animal is injured, the Contractor shall contact the police and/or fish and wildlife officials, who will determine and arrange for the action required;
- In cases involving livestock, the Contractor shall remove the carcass from the roadway surface and contact the owner of the animal to dispose of the carcass. If the owner cannot be contacted, the Contractor shall remove the carcass from the Road Right of Way, dispose of the carcass at an approved site and immediately notify the Department;
- Repairing traffic signals and advanced warning devices, including without limitation:
 - Resetting signals if the lights are in flash mode;
 - Replacing burned-out bulbs; or
 - When the lights are completely out of service, setting up portable STOP signs from all directions until permanent repairs occur;
- Responding to accidents or natural disasters, including without limitation:
 - Traffic control, including erecting detours or barricades in accordance with appropriate traffic control requirements;
 - Supply and erection of emergency signs;
 - Cleaning-up the accident or disaster site;
 - Removing from the roadway surface, any material including damaged guardrail which presents a hazard to the travelling public;
 - Applying absorbent material to minor spills at accidents;
 - Placing “Police Emergency Ahead” signs at the scene of collisions, spills or obstructions on the roadway;
 - Providing emergency traffic control and arrowboards;
 - Reopening of the roadway within one hour of clearing the accident or natural disaster; and
 - Communication with, coordinating with, and providing access for, emergency response services that may be required on the Infrastructure or be required to pass over the Infrastructure;
- Notification of and cooperation with the relevant emergency and/or regulatory authorities in the containment and clean up of all spills including those in ditches and ponds;
- Providing adequate marking of any conditions on the roadway surface or in the Road Right of Way which are a hazard to the travelling public:
 - Emergency repair and marking of unsafe or poor pavement conditions; and
 - Emergency repair and/or marking of unsafe or poor bridge structure conditions; and
- Reporting to the Department any instance where immediate response was required.

500.2.3 ROUTINE MAINTENANCE

The Contractor's routine maintenance activities shall include, but not be limited to, the following:

- Removing and disposing of incidental refuse and litter from within the Road Right of Way;
- Straightening or reinstalling sign posts;
- Shimming and tightening connections on breakaway sign posts as required;
- Straightening or reinstalling delineator posts and replacing reflective strips on guardrails and delineator posts;
- “Summerizing” signals and control boxes;
- “Winterizing” signals and control boxes;
- Washing signs, delineators and reflective strips on guardrail. If soap is used, it must be biodegradable;
- Removing graffiti from all sites;
- Removing non-conforming signs from within the Road Right of Way;
- Performing annual inspections of all drainage system components, scheduling required maintenance and drainage, and completing such maintenance and drainage prior to freeze-up each year;
- Removing minor blockages in the drainage system on a regular basis; and
- Removing, collecting and disposing of winter sand, tracked dirt and all other debris from the roadway.

500.2.4 MEASURING FOR COMPLIANCE

For all roadway inspection, emergency maintenance and routine maintenance requirements the Contractor shall undertake the work within the time periods stipulated and in accordance with the Contractor’s Operations and Maintenance Plan (Section 100.2.9).

500.2.5 PAYMENT ADJUSTMENTS

If the roadway inspection, emergency maintenance and routine maintenance are not completed within the required time period on the Infrastructure, the Contractor shall be assessed the following Payment Adjustments.

In this section, “occurrence” refers to an occurrence anywhere on the Infrastructure.

If the Contractor fails to undertake the roadway inspections, Payment Adjustments shall be made as follows. The number of occurrences of non-conformance shall be determined for a consecutive 12 month period.

- \$2,000 for the first occurrence;
- \$4,000 for the second occurrence;
- \$8,000 for the third occurrence; and
- \$16,000 for the fourth occurrence and each occurrence thereafter.

If the Contractor fails to undertake routine maintenance in any consecutive 12 month period, Payment Adjustments shall be made as follows:

- \$4,000 for the first occurrence;
- \$8,000 for the second occurrence;
- \$16,000 for the third occurrence, and each occurrence thereafter.

If the Contractor fails to undertake emergency maintenance in any consecutive 12 month period, Payment Adjustments shall be made as follows:

- \$16,000 for the first occurrence;
- \$32,000 for the second occurrence; and
- The third occurrence shall be a potential Termination Event for the purposes of and having the consequences set out in Section 16.8(k) of the DBFO Agreement.

The Department shall notify the Contractor after the first and second occurrence of non-compliance with an emergency maintenance performance requirement in any consecutive 12 month period.

500.2.6 REPORTING PROCEDURES

All actions taken related to Section 500.2.2 (Emergency Maintenance) shall be reported immediately to the Department.

The Contractor shall record conditions identified during roadway inspections, and any work performed as a result of the observations. Such information shall be reported to the Department. The report shall make a distinction between conditions that required immediate response and those that could be scheduled as future work.

The Contractor shall record and report monthly, all Routine Maintenance performed.

These reports shall include:

- Segment(s) worked; and
- Action(s) taken.

500.3 WINTER MAINTENANCE OPERATION REQUIREMENTS

500.3.1 GENERAL

When undertaking winter maintenance operations, the Contractor shall coordinate its operations to achieve Bare Pavement (as defined below) conditions on all driving lanes and pathways or walkways. “Bare Pavement” is defined as the travel lanes, and walkway/pathways being free of snow, packed snow, frost or ice. Gore areas may have accumulation of loose snow not more than 100 mm and shoulders may have an accumulation of loose snow not more than 30 mm. Drainage points shall be kept free of snow and debris.

All roadways within the Existing Infrastructure shall have a class assigned to each segment, as described in the following table, on the basis of AADT for that segment. The AADT for all segments shall be determined in accordance with Section 200.3.1 (Traffic Volume Payment Adjustments).

Winter snow clearing and ice control traffic segments may change in length or class depending on the changes in traffic volume (AADT), throughout the Operating Period.

The following table defines the requirements for snow clearing and ice control for the Existing Infrastructure.

Should winter snow and ice conditions dictate, the “Max. Time to Bare Pavement” requirement may be waived by the Department if the temperature after the “Max. Time to Bare Pavement” is below the indicated value in the last column of the following table. During this time of cold temperatures, the Contractor shall apply winter abrasive material and attempt to physically remove ice and packed snow from the roadway surface. At all times, abrasives will be present on all slippery surfaces within the driving lanes, to ensure safety for the travelling public.

Once temperature rises above the indicated value in the last column of the following table, the “Max. Time to Bare Pavement” requirement shall recommence, and the Contractor will have the full time to achieve Bare Pavement.

A “Severe Storm Event” is defined as:

- a. A combination of heavy snowfall over a short duration, accumulation of more than 2 cm/hr, or snowfall greater than five days duration, wetter snow, and high winds that results in visibility conditions such that snowplow operations become hazardous and such operations should reasonably cease for several hours;
- b. A wind event where the wind is greater than 60 kph for four consecutive hours; or

- c. A freezing rain or hail event where the accumulation on fixed objects is greater than 6 mm.

Winter Maintenance Standards							
Class	AADT Range	Max. Time to React (hrs)	Max. Time to Bare Pavement (hrs)	Clean Up (hrs)	Severe Storm Event		Max. Time to Bare Pavement Temperature Waiver (°C)
					Max. Time to Bare Pavement (hrs)	Clean Up (hrs)	
A	0 to 30 000	1.5	5	48	10	120	-10
AA	30 001 to 75 000	1.0	3	48	6	120	-15
AAA	75 001 to 125 000	0.5	2	24	4	96	-20
AAAA	125 001 and above	0.5	2	24	4	72	-30

Pathways and walkways shall be cleaned of snow within 48 hours of the end of the Storm Event (as defined below).

The reaction time shall be measured from the time that the Contractor is made aware or notified, or becomes aware or should have been aware of, the need to mobilize equipment and to the time the Contractor starts to engage in snow/ice removal activities with the appropriate equipment. The Contractor shall have engaged snow/ice control activities prior to an accumulation of 15 mm of loose snow. The Contractor may be made aware by its own forces, by the Department, Local Authorities or by police authorities.

The time to Bare Pavement shall be measured from the end of the Storm Event. “Storm Event” shall be defined as a period of time of continuous precipitation and/or condensation and/or wind causing the formation of snow and/or ice on the roadway surface. The end of a storm event shall be considered the last known time of precipitation, heavy snow drifting or condensation affecting the roadway.

Clean up shall be undertaken after the Storm Event. Banks or drifts of snow greater than 0.5 m shall be removed to at least 2 m from all high speed (posted 100 km/hr or greater) driving surfaces. Intersection sight distance shall be restored on all ramps, intersections and crossroads. Time to complete clean-up is measured from the time precipitation or heavy snow drifting has stopped to the time all clean-up activities are complete.

The Contractor shall prepare an annual specific and updated Snow Clearing and Ice Control Operations Plan that meets the requirements of Section 500.3 (Winter Maintenance Operation Requirements). The plan must be acceptable to the Department and in place by September 15th of each year.

The winter maintenance operation requirements for Shaganappi Trail shall meet or exceed the standards for such then current requirements maintained by the City for Shaganappi Trail north and south of the TUC.

During a Major Snowfall Event (as defined below), the Contractor shall provide a minimum level of snow removal service that includes maintaining one driving lane open

in both directions (including on/off ramps). The Contractor shall return to the snow removal effort required to achieve Bare Pavement conditions as soon as the snowfall begins to subside. A “Major Snowfall Event” is defined as one where there is heavy snowfall over a short duration, accumulation of more than 2 cm/hour, or snowfall greater than five days in duration.

The Snow Clearing and Ice Control Operations Plan must provide for the deployment of snow plows and spreader equipment capable of meeting the following objectives:

- The Existing Infrastructure roadways must be open to the driving public at all times, unless the Department closes the road;
- All lanes remain operational during snow conditions;
- Plowing shall commence prior to snow accumulation reaching 15 mm on any roadway. The maximum allowable accumulation of loose snow on the roadway is to be 30 mm;
- The deployment of snowplows and spreader units shall be calculated based on these requirements and the locations of the Contractor’s sand and salt stockpiles;
- If required to meet labour and plowing standards and/or where storm intensities are beyond the capabilities of the normal snow removing equipment complement during storms which last more than 48 hours, identify a procedure for obtaining and deploying additional resources;
- Snow plows and spreader units shall respond within the applicable response times;
- Include a contingency plan to address storm conditions which may force the closure of the roadway facility or instances where traffic prevents the deployment of the standard snowplow/equipment complement;
- Plowing coverage shall provide for the continuous integrated plowing of both shoulder and surface of the roadway facility including interchange ramps, intersections and cross-roads;
- Snow plowing on bridges shall be done to prevent snow from being thrown onto underlying roadway or railways;
- A plan for meeting the Section 500.3 (Winter Maintenance Operation Requirements), in case of a winter storm or winter driving conditions, during the non-winter months;
- Address the cover-off of equipment operators who meet their “Hours of Service” limits or tire. Provide cover-off operators and ensure all equipment remains operational and operated, for the duration of the storm and for the clean-up periods;
- Provide for the provision of regular winter condition reporting to the Department and the Alberta Motor Association (“AMA”) or any other agency identified by the Department; and
- Coordinate winter maintenance with the Local Authority.

The accepted Snow Clearing and Ice Control Operations Plan shall be adhered to throughout the Operating Period.

500.3.2 EQUIPMENT AND MATERIALS

The Contractor's Snow Clearing and Ice Control Operations Plan (see Section 500.3.1) shall include periods for which the level of equipment shall be available throughout the winter months and identify levels of equipment that will be available during non-winter months to respond to snow falls during these periods.

Specifications for plow and sanding trucks shall, as a minimum, be in accordance with applicable law, including without limitation the *Traffic Safety Act* (Alberta) and any regulations thereunder and any replacement or successor legislation, and applicable Department standards, as identified in *Alberta Transportation Maintenance Contracts for Rural Highways*.

Sand and salt materials shall be stored in a manner identified in the EMS (Section 100.2.2). The TAC *Synthesis of Best Practices – Road Salt Management* shall be used as a guideline. The Contractor shall adjust the materials storage and handling practices as necessary to address changes or developments in the environmental concerns for any of the materials used.

500.3.3 SNOW CLEARING AND ICE CONTROL
OPERATIONS

The Contractor shall conduct all winter maintenance activities with the objective of achieving Bare Pavement (as defined in Section 500.3.1) conditions as quickly as possible and in all cases within the stipulated time periods. Activities shall comply with the accepted Snow Clearing and Ice Control Operations Plan (see Section 500.3.1) and the following:

- The required complement of snow plows shall be deployed within the time limits identified;
- Emergency vehicles and equipment shall be deployed on the roadway system in the event that the standard equipment complement cannot meet the Section 500.3 (Winter Maintenance Operation Requirements);
- Snow plows and sand/salt spreader trucks shall be operated in accordance with applicable laws and regulations;
- Snow/ice equipment shall be operable and operated on a 24 hour basis, throughout the Storm Events (as defined in Section 500.3.1) and subsequent clean up;
- All equipment shall be operated with due diligence to prevent damage to the Existing Infrastructure, and with due regard for the safety of the travelling public; and
- The Contractor shall be responsible for any and all damages.

500.3.3.1 Measuring For Compliance

The Contractor shall monitor its performance relative to Section 500.3 (Winter Maintenance Operation Requirements) and record all response times and snow and ice accumulations in the maintenance management record which shall be provided to the Department on a monthly basis.

500.3.3.2 Non-Compliance

If the Contractor fails to comply with any of Section 500.3 (Winter Maintenance Operation Requirements), despite such a failure, the Contractor shall immediately mobilize in order to minimize snow and ice accumulations.

If non-compliance is observed, Payment Adjustments will be assessed against the Contractor.

Non-compliance is defined as any one of the following:

- The Contractor fails to deploy equipment in accordance with the accepted Snow Clearing and Ice Control Operations Plan (see Section 500.3.1);
- The Contractor has failed to deploy additional resources in accordance with the Snow Clearing and Ice Control Operations Plan;
- The Contractor has failed to plow/remove and/or apply materials as identified in the accepted Snow Clearing and Ice Control Operations Plan;
- The Contractor failed to meet the deployment time frames;
- The Contractor fails to achieve Bare Pavement (as defined in Section 500.3.1) or no ice conditions within the specified time frames following the end of a Storm Event (as defined in Section 500.3.1); and
- The Contractor fails to supply any ice control materials.

500.3.3.3 Payment Adjustments

When the Contractor is non-compliant, Payment Adjustments shall be made as follows:

- \$10,000 for each occurrence of non-compliance during a Storm Event (to a maximum of \$60,000 total for the Infrastructure);
- \$20,000 for each occurrence of non-compliance during a subsequent Storm Event in any consecutive 12 month period (to a maximum of \$120,000 total for the Infrastructure); and
- The third occurrence of any non-compliance within a consecutive 12 month period but in a separate third Storm Event shall be a potential Termination Event for the purposes of and having the consequences set out in Section 16.8(k) of the DBFO Agreement.

The number of occurrences of non-conformance shall be determined for a consecutive 12 month period.

The Department shall notify the Contractor after the first and second occurrences of non-compliance in any consecutive 12 month period. In this section, “occurrence” refers to an occurrence anywhere on the Infrastructure.

500.3.4 PREFERENTIAL BRIDGE DECK ICING

The Contractor shall implement and carry out the Preferential Bridge Deck Icing Plan (see Section 100.2.9). For the purposes of the Technical Requirements, “preferential bridge deck icing” shall mean ice formation within the driving lanes of a bridge deck during a weather circumstance when ice formation within the driving lanes of the roadway leading to and from such bridge deck is not occurring.

500.3.4.1 Measuring for Compliance

The Contractor shall monitor its performance relative to the Preferential Bridge Deck Icing Plan and record all occurrences of preferential bridge deck icing and response times in a maintenance management record which shall be provided to the Department on a monthly basis.

500.3.4.2 Non-Compliance

The Contractor shall be in non-compliance under this Section 500.3.4.2 if preferential bridge deck icing is observed within any of the driving lanes on any of the PBD Bridges (as defined in Section 200.2.16) and either:

- such icing has occurred as the result of the Contractor’s failure to comply with the current Preferential Bridge Deck Icing Plan; or
- upon becoming aware of such preferential bridge deck icing, the Contractor fails to immediately mobilize in order to reasonably minimize such preferential bridge deck icing; or
- preferential bridge deck icing has previously occurred on any of the PBD Bridges under the same Preferential Bridge Deck Icing Plan during a prior distinct weather circumstance occurring in the prior 12 month period,

(each a “Preferential Bridge Deck Icing Non-Compliance Event”).

500.3.4.3 Payment Adjustments

When the Contractor is non-compliant pursuant to Section 500.3.4.2, Payment Adjustments shall be made as follows:

- \$10,000 for each occurrence of a Preferential Bridge Deck Icing Non-Compliance Event during a distinct weather circumstance (to a maximum of \$60,000 total for the Infrastructure) (the “First Set of Occurrences”);
- \$20,000 for each occurrence of a Preferential Bridge Deck Icing Non-Compliance Event following the First Set of Occurrences during a subsequent but separate and distinct weather circumstance in any consecutive 12 month period (to a maximum of \$120,000 total for the Infrastructure) (the “Second Set of Occurrences”); and
- The third occurrence of any Preferential Bridge Deck Icing Non-Compliance Event within a consecutive 12 month period but during a separate and distinct weather circumstance shall be a potential Termination Event for the purposes of and having the consequences set out in Section 16.8(k) of the DBFO Agreement.

The number of occurrences of non-compliance shall be determined for a consecutive 12 month period.

The Department shall notify the Contractor after the First Set of Occurrences and the Second Set of Occurrences in any consecutive 12 month period. In this section, “occurrence” refers to an occurrence anywhere on the Infrastructure.

500.3.4.4 Plan Replacement

The Contractor shall be entitled at any time to replace the Preferential Bridge Deck Icing Plan provided such replacement plan shall be reasonably designed to prevent preferential bridge deck icing from occurring on the PBD Bridges (as defined in Section 200.2.16), including without limitation be reasonably designed to rectify any previous failures in preventing preferential bridge deck icing, and is reviewed in accordance with Schedule 5 (Design and Plan Certification and Review Procedure).

500.4 ROADWAYS

500.4.1 GENERAL PAVEMENT MAINTENANCE REQUIREMENTS

The Contractor shall maintain all pavement sections including shoulders and gore areas on a regular basis in order to ensure that they remain in a safe condition and continue to provide the service for which they were intended recognizing the Contractor is not responsible for rehabilitating the Existing Infrastructure. The repair methods for localized deficiencies, localized roughness, and localized cracking for both asphalt and Portland cement concrete pavements shall be as indicated in Section 100.2.9 (Operation and Maintenance Plan).

The Contractor is not responsible for any work at joints in the Portland cement concrete pavement of the Existing Infrastructure, where work such as mud jacking and grinding, is due to slab movements.

The Contractor shall maintain the pavement surface in a safe condition. If a pavement deficiency is a hazard to motorists, it shall be repaired immediately regardless of size. The responsibility for the cost of the repair shall be governed by the DBFO Agreement and other applicable provisions of the Technical Requirements. The Contractor will be responsible for reporting any pavement related problems with skid resistance, roughness, cross-slope, superelevation or other structural deficiency to the Department on a timely basis. The following sections provide detailed requirements.

“Localized” in this Section 500.4 is defined as areas within one metre or less from each other.

500.4.1.1 Localized Deficiencies

Localized deficiencies within any travel lane which are > 0.1 square metre shall be repaired within 24 hours following the time when the Contractor became aware, or should have become aware, of the deficiency. Localized deficiencies which are not located within the travel lanes and/or do not exceed 0.1 square metres shall be repaired within 21 days following the time when the Contractor became aware, or should have become aware, of the deficiency. Spalling or other distress at crack locations and joints shall be treated as a localized deficiency.

500.4.1.2 Localized Roughness

All areas of the pavement shall be maintained true to lines and grades. Localized areas, such as transverse cracks or joints, shall be maintained to prevent localized roughness. Deficiencies which cause localized roughness shall be repaired. The definition of localized roughness shall be any abrupt deviation in excess of 6 mm when measured with a 1.2 m straight edge.

500.4.1.3 Localized Cracking – Asphalt Concrete Pavements

All transverse cracks between 2 mm and 25 mm in width and all longitudinal cracks between 2 mm and 12 mm in width shall be routed and sealed. Routed cracks with missing sealant shall be re-sealed. Transverse cracks greater than 25 mm and longitudinal cracks greater than 12 mm are to be spray patched. The Contractor shall prepare and carry out a crack sealing program annually, with a completion date for the work of August 31 each year of the Operating Period.

500.4.1.4 Localized Cracking – Portland Cement Concrete Pavements

All random cracks between 2 mm and 20 mm in width shall be sawn/routed and sealed. Sawn/routed cracks with missing sealant shall be re-sealed. The Contractor shall prepare and carry out a crack sealing program annually, with a completion date for the work of August 31 each year of the Operating Period.

500.4.1.5 Measuring For Compliance

The Contractor shall inspect the Existing Infrastructure on a continual basis as part of the schedule of inspection, and shall identify deficiencies related to Section 500.4.1 (General Pavement Maintenance Requirements).

500.4.1.6 Completing Repairs

The Contractor shall undertake any required repairs within the time lines indicated for the specific maintenance need. Where a specific timeline is not indicated, the repairs shall be undertaken within 30 days of the time the Contractor became aware, or should have become aware, of the deficiency. Maintenance repair requirements apply year-round and may be required during poor weather conditions.

500.4.1.7 Payment Adjustments

If repairs, permanent or otherwise, are not completed for localized deficiencies and localized roughness within the stipulated time period, the Contractor shall be assessed

Payment Adjustments at a rate of \$500/required repair for each seven day period or any partial week, until the deficiency is corrected.

If the annual crack sealing programs are not completed by August 31 each year, the Contractor shall be assessed a Payment Adjustment of \$2,000/km or any partial km, of single direction unsealed mainline, C-D road, ramp or crossroad/month or portion thereof, until the annual programs are complete.

500.4.2 MISCELLANEOUS OPERATION AND PERFORMANCE REQUIREMENTS

This Section 500.4.2 covers the performance requirements of specific appurtenances and maintenance activities that must be performed to a specified standard by the Contractor. Notwithstanding the foregoing sentence but subject to the DBFO Agreement, all infrastructure associated with this Existing Infrastructure shall be maintained in an adequate condition and function as designed.

Non-specified items of the Existing Infrastructure such as, but not limited to, backslope, sideslope, or embankment movements, fencing, and pavement shoulders or gore areas shall be maintained to a level consistent with standard practice. Non-specified items shall be monitored and maintained in accordance with standard industry practice.

500.4.2.1 Delineators

Delineators shall be maintained clean at all times and shall exhibit a minimum retroreflectivity of 80% of design value.

The Contractor shall maintain delineator guideposts plumb within 50 mm throughout their length.

Delineators shall be maintained within 5% of design height and shall not deviate from design locations by more than 50 mm.

Delineators shall be maintained to provide the intended delineation at all times. Delineators that are damaged, or otherwise removed, such that they are not providing the desired delineation shall be replaced.

500.4.2.1.1 Measuring For Compliance

The Contractor shall identify damaged, missing or otherwise ineffective delineators during roadway inspections. At least once per year, the Contractor shall complete a visual inspection and, when required (i.e. vertical alignment more than 50 mm out of plumb), shall realign delineator guideposts to within 13 mm of plumb throughout their length.

500.4.2.1.2 Completing Repairs

Delineators that become soiled shall be cleaned within seven days providing weather conditions permit.

Delineators that are damaged, missing or otherwise fail to function as designed shall be replaced within seven days.

500.4.2.1.3 Payment Adjustments

Payment Adjustments shall be assessed against the Contractor for each delineator which does not comply with the requirements of this Section 500.4.2.1 within the stipulated time period at a rate of \$20/delineator/day or any partial day, until made to comply.

500.4.2.2 Roadway Lighting

Roadway lighting includes all lights designed and constructed for the Existing Infrastructure or subsequently added to the Existing Infrastructure. The Contractor shall undertake the necessary maintenance to ensure that the desired illumination is provided to motorists at all times. The Contractor shall inspect the operation of the roadway lighting system on a regular basis and this shall be included in the Contractor's QMS (Section 100.2.1). The Contractor is responsible for:

- Repair and/or replacement of individual lights/luminaires to provide light output in accordance with the manufacturer's rated design parameters and overall illumination in accordance with the design;
- Repair and/or replacement, with new materials, any parts of the lighting system damaged through accidents; and
- Conducting a regular monitoring program for evaluating the condition of all roadway lights, including the supporting infrastructure and reporting deficiencies in light standards, bases, power supply or other non-luminaire elements to the Department. Such reporting must be on a regular basis to allow the Department to initiate action to maintain the integrity of non-luminaire elements in a satisfactory operating condition.

500.4.2.2.1 Measuring For Compliance

The Contractor shall conduct a regular monitoring program for evaluating the condition of all roadway lights, including all supporting infrastructure, within the Existing Infrastructure. The Department may inspect lights at any time and notify the Contractor of any non-compliance to the Technical Requirements.

500.4.2.2.2 Completing Repairs

The Contractor shall undertake repairs within the following guidelines, from the time the deficiency is known, or should have been known, to the Contractor:

- Outage of 2 or less consecutive lamps shall be repaired within 96 hours.
- Outage of 2 to 5 consecutive lamps shall be repaired within 72 hours.
- Outage of more than 5 consecutive lamps shall be repaired within 48 hours.
- Repair or replacement of lighting infrastructure damaged by an accident shall be done within seven days.

An outage is defined as total failure of the lamp to light, failure of the lamp to produce the manufacturer's rated output (to such an extent that it is visually apparent when compared to other lamps), intermittent lighting caused by cycling on and off, or light is prevented from being properly distributed to the roadway surface.

500.4.2.2.3 Payment Adjustments

The Contractor shall be assessed Payment Adjustments for failing to adjust, maintain, repair/replace lamps or components of the roadway lighting system within the stipulated time as follows:

- Lamp repair/replacement, \$100/lamp/day or any partial day, that the lamp remains in need of repair/replacement; and
- Repair or adjustment of any pole, base or other lighting system component, \$100/component/day or any partial day, that the component needs adjustment.

500.4.2.3 Barriers and Guardrail

Barriers and guardrail shall be maintained to function as designed and to have a neat and tidy appearance at all times. The Contractor shall inspect the condition of guardrail on the Existing Infrastructure on a regular basis and this shall be included in the Contractor's QMS (Section 100.2.1). The following shall apply:

- Barriers and guardrail shall be visible at all times and reflective markers shall be clean and function as designed;
- Guardrail damaged by collision shall be replaced. When guardrail is damaged it shall be repaired immediately to assure the continued protection of the travelling public. When immediate permanent repair is not possible, temporary repairs shall be implemented immediately. Permanent repairs shall be with new material and shall be installed to original design specifications; and
- The Contractor shall conduct a regular monitoring program for evaluating the condition of all guardrails and reporting deficiencies in the guardrail installations to the Department. Such reporting must be on a regular basis to allow the Department to initiate action to maintain the operational effectiveness of the guardrail installations on the Existing Infrastructure.

500.4.2.3.1 Measuring For Compliance

The Contractor shall undertake daily inspections of all barriers and guardrail sections within the Existing Infrastructure.

500.4.2.3.2 Completing Repairs

In situations when barriers or guardrails are missing or damaged such that they do not function as intended, the Contractor shall undertake repairs or temporarily protect the area immediately. All other non-compliant sections of barrier or guardrail shall be repaired within 60 days. In instances where temporary repairs are required, such temporary repairs may not be in place for more than five days. In winter months when permanent repairs may not be possible due to freezing conditions, temporary measures may stay in-place until the ground is free of frost.

500.4.2.3.3 Payment Adjustments

Following the expiration of the specified time-frame for completing repairs, or in the case where temporary repairs have been in-place until weather permits repairs to be more reasonably undertaken, a Payment Adjustment of \$200/metre/day or any partial day, of non-compliant barrier or guardrail shall be assessed until the repairs are completed.

500.4.2.4 Grass Cutting and Landscape Maintenance

500.4.2.4.1 General

The Contractor shall maintain the vegetation in all areas of the Road Right of Way and stormwater management facilities. The Contractor shall remove and dispose of any dead vegetation and re-seed grass if necessary to retain the overall landscaping within the Road Right of Way and stormwater management facilities.

Grass within the Road Right of Way and stormwater management facilities shall not exceed 300 mm in height, at any time.

Weed control shall be carried out, by the Contractor, as required to control noxious weeds including all noxious weeds identified under the *Weed Control Act* (Alberta) and Local Authority bylaws.

500.4.2.4.2 Weed Control

500.4.2.4.2.1 Operating Standards, Approvals and Permits

The Contractor shall comply with the operating standards and practices of the Industrial Vegetation Management Association of Alberta and shall have a service approval

agreement from Alberta Environment, or its successor. All personnel applying chemicals shall have a valid applicators license issued by Alberta Environment, or its successor.

Special use approvals issued by Alberta Environment, or its successor, will be required in instances where chemicals are to be sprayed within 30 m of an open body of water. In such instances, the Contractor shall advertise the proposed work in newspapers local to the area, 30 days prior to the scheduled starting date of the work.

The Contractor shall provide the Department with a copy of the newspapers containing the advertisement. All public concerns shall be referred, by the Contractor, to Alberta Environment, or its successor, who will identify any work conditions in the approval. The Contractor shall be responsible for obtaining the special use approval and shall comply with the conditions specified therein.

The Contractor is liable for any damage caused to areas outside the Road Right of Way occasioned by its use of chemicals for weed control and shall promptly handle any damage claims in this regard. The Contractor shall also pay any fines/penalties assessed by the governing authority for failure to promptly comply with applicable requirements.

The Contractor shall not be responsible for watering or re-planting materials but shall be responsible for the weed control within the designated areas of the Existing Infrastructure, including the planting areas, and shall be responsible for the removal of dead vegetation. The Contractor shall be responsible for the planting material if the Contractor, or those for who it is legally responsible, has caused the damage.

500.4.2.4.2.2 Materials

The Contractor shall select and supply the appropriate chemical for vegetation control. Only chemicals approved by the appropriate department of the Federal Government for general industrial spraying shall be used. The Contractor shall supply any signs required to identify treated areas in public use areas.

500.4.2.4.2.3 Procedures

The Contractor's use of chemicals, application rates and methods shall comply with the policies, rules and regulations of Alberta Environment, or its successor. The Contractor shall maintain accurate records of all applications including the type and amounts of chemicals used and the locations treated. If requested, the Contractor shall supply this information to the Department along with copies of the bills of lading and the manufacturer's recommended application rates for the chemicals used. The Contractor shall dispose of empty chemical containers only at approved disposal sites.

500.4.2.4.2.4 Measuring For Compliance

The Contractor shall undertake periodic inspections of all areas of the Road Right of Way and stormwater management facilities to assess the need for any type of landscape

maintenance including grass cutting, re-seeding/re-planting, weed control and the removal of dead vegetation. The monitoring program shall comply with the program documented in the Contractor's EMS (Section 100.2.2). The Department may inspect landscaping at any time and notify the Contractor of any non-compliance to these specifications.

Alberta Environment, or its successor, and the Local Authority will also inspect for noxious weeds and any order or direction given to the Contractor regarding deficiencies in compliance shall be dealt with immediately.

500.4.2.4.2.5 Completing Repairs

When the Contractor fails to observe the need for maintenance, or fails to undertake maintenance within two weeks, then the Contractor will be considered non-compliant and the specified Payment Adjustments will be applied.

500.4.2.4.2.6 Payment Adjustments

Payment Adjustments shall be assessed against the Contractor on the following basis:

- Grass in excess of the specified maximum height, \$100/hectare or any partial hectare/month or any partial month, for any portion of a hectare that fails to meet these requirements

500.4.2.5 Litter Clean Up

The Contractor shall maintain the Road Right of Way and the drainage system to be reasonably free of litter. The Road Right of Way must be free of any and all litter that may cause damage to vehicles, or otherwise result in a safety hazard for roadway users. The Contractor shall:

- Conduct an annual litter clean up, each spring. Following the annual clean up no litter shall be visible within the Road Right of Way and drainage system;
- Conduct litter clean up, to the same standard as the spring clean up, on or about July 30 and September 30 each year during the Operating Period. In addition, the Contractor shall clean up any litter that covers more than 0.025 cubic metres (one cubic foot) in size or greater within the Road Right of Way or the drainage system within one week of observing the litter;
- Remove litter, including dead animals, on the roadway that has the potential to affect traffic immediately and dispose of. Dead animals at any other location on the Road Right of Way or the drainage system shall be removed within six hours of being observed and disposed of;
- Remove abandoned vehicles within 24 hours in co-operation with policing authorities;

- Remove graffiti from any location visible from the roadway within 96 hours. Graffiti that cannot be effectively removed shall be covered with appropriate materials; and
- Remove all waste or other litter generated by the Contractor's operation.

Notwithstanding the above requirements for litter clean-up the Contractor shall work with and co-ordinate with policing authorities and registered motor vehicle owners and their insurers to facilitate clean-up of debris resulting from accidents within the Road Right of Way.

500.4.2.5.1 Measuring For Compliance

The Contractor shall undertake periodic inspections of all areas of the Road Right of Way and drainage system to assess the need for litter clean up.

The Contractor will be considered to be non-compliant with this Section 500.4.2.5 if any of the following occur:

- An annual spring clean-up campaign has not been conducted, or has been conducted but has not removed all visible litter from the Road Right of Way and drainage system, by June 1st of each year;
- The specified summer and fall clean up operations have not been completed by August 15 and October 15 respectively in each year;
- Litter that poses a hazard has not been removed within the specified time period;
- The Department or the Contractor identifies that the Road Right of Way and drainage system is littered and unsightly and such litter is not removed within the specified time frame;
- Abandoned vehicles are not removed within the specified time frame;
- Graffiti is not removed or appropriately covered within the specified time frames; and
- Waste generated by the Contractor has not been removed within one week of the completion of the work associated with the waste, or if such waste is creating an unsightly or hazardous condition.

500.4.2.5.2 Completing Clean Up

When the Contractor fails to observe the need for litter clean-up, or fails to undertake clean-up required within the specified time, then the Contractor will be considered non-compliant and the specified Payment Adjustments shall be applied.

500.4.2.5.3 Payment Adjustments

If the Contractor is determined to be non-compliant, a Payment Adjustment of \$250/day, or any partial day, shall be assessed for each and every occurrence of non-compliance. An occurrence is any single or multiple non-compliance. Payment Adjustments for litter clean up are cumulative but shall not exceed \$500/day. The Payment Adjustment shall be assessed for each day, or portion thereof, until the cleanup is completed.

500.4.2.6 Drainage Systems

Drainage systems shall be maintained to function as designed and to assure that environmental requirements are met at all times.

The Contractor shall undertake drainage maintenance system to ensure that the roadway surfaces and all other elements of the Existing Infrastructure are safe and effectively drained.

The requirements of this section apply to any aspect of the Existing Infrastructure that serves a drainage function, including, but not limited to:

- Drainage structures;
- Culverts;
- Ditches;
- Stormwater management facilities;
- Curb and gutter (drainage function);
- Manholes, inlet and outlet structures, catch basins, flumes; and
- Storm sewers.

The Contractor shall ensure that environmental requirements required by legislation or design are met at all times and shall maintain all aspect of the drainage facilities to prevent the discharge of silt or sediments into water courses.

Drainage system elements shall be maintained to assure full hydraulic and structural capacity.

Ditches, sideslopes, backslopes and any land within the Road Right of Way, the drainage system and/or parts of the TUC drained by the Existing Infrastructure system shall be protected from erosion, including wind erosion. The Contractor shall be responsible for any damage to the Road Right of Way, the TUC, or any lands adjacent the TUC caused by a deficiency in the Contractor's maintenance of the drainage system for the Existing Infrastructure.

The Contractor shall manage the drainage system such that deficiencies are repaired immediately if erosion or sedimentation is a potential, or within one year for all other repairs.

500.4.2.6.1 Measuring For Compliance

The Contractor shall complete regular inspections of the Existing Infrastructure to assess the function of the drainage systems and to schedule maintenance and repairs.

500.4.2.6.2 Completing Repairs

The Contractor shall plan for and complete repairs to the drainage system on an annual basis. Drainage deficiencies identified by the Contractor's inspection shall be corrected within two months excepting if such repairs are necessary to prevent the potential for ponding of water on the road surface or if potential for erosion or sedimentation exists, in which case repairs shall be made immediately.

500.4.2.6.3 Payment Adjustments

The ponding of water on the road surface at anytime is not acceptable. For each and every case in which ponded water remains on the road surface for greater than 60 minutes, the Contractor shall be assessed a Payment Adjustment per day, or portion thereof, until the water is removed and the cause of the ponding is rectified.

For paved areas with ponds up to 4 m² the Payment Adjustment shall be \$1,000/pond/day or any partial day. For paved areas with ponds in excess of 4 m² a Payment Adjustment of \$5,000/pond/day or any partial day, shall be made.

If erosion of lands occurs, the Contractor shall be assessed a Payment Adjustment if it is not repaired, and the cause rectified within one week of the time of the Contractor becoming aware or should have been aware of the deficiency, of \$500/day or any partial day, until repairs are complete.

For all other drainage system deficiencies, the Contractor shall complete the necessary repairs within the stipulated time period or be assessed a Payment Adjustment of \$100/day or any partial day, for each deficiency, until the deficiency is repaired.

500.4.2.7 Curb and Gutter

Curb and gutter and any associated works shall be maintained to function as designed recognizing the Contractor is not responsible for the rehabilitation of the Existing Infrastructure. The following shall apply:

- Curb and gutter shall be maintained to ensure that their function in overall drainage and driver guidance is maintained at all times;
- Curb and gutter shall be maintained to ensure no ponding of water anywhere along the length of the curb, within the gutter or on any roadway or shoulder;
- Broken or damaged concrete shall be replaced when required to restore functionality;
- Scaling of a concrete surface shall be limited to no more than 10% of surface area in any five lineal metre section of curb and gutter; and
- Cracking of concrete shall be limited to a maximum crack width of 3 mm, occurring at a maximum frequency of one crack every 2 m.

500.4.2.7.1 Measuring For Compliance

The Contractor shall undertake periodic inspections of all curb and gutter sections within the Existing Infrastructure for the purpose of evaluating the functionality and the condition of the concrete materials.

500.4.2.7.2 Completing Repairs

The Contractor shall complete repairs to restore the functionality of the curb and gutter sections to the level and alignment for which they were originally designed. General repairs shall be completed within 180 days of the time when the Contractor knew of, or should have known of, the deficiency. Replacement of curb and gutter for surface scaling and/or cracking which do not impair functionality shall be completed within 180 days of the time when the Contractor knew or should have known of the deficiency.

500.4.2.7.3 Payment Adjustments

Payment Adjustments for each instance where a curb and gutter section does not conform to the Technical Requirements, and is not repaired within the stipulated time period, shall be \$1,000/occurrence/day or any partial day, until rectified.

500.4.2.8 Sidewalks

Sidewalks shall be maintained to function as designed. The Contractor shall undertake the necessary maintenance to ensure that any sidewalks within the Existing Infrastructure are maintained in a condition that is safe for pedestrian traffic. The following shall apply:

- Vertical displacement at joints or cracks that exceed 5 mm shall be repaired or replaced to remove the differential elevation and remove any tripping hazard;
- Concrete that is cracked in multiple locations within the same general area of a sidewalk or otherwise results in a discontinuity that may pose a tripping hazard or be a safety concern shall be removed and replaced;
- Concrete surfaces that exhibit scaling over more than 15% of the surface area in any 1 m² section and results in a rough surface texture shall be removed and replaced; and
- Crack widths in excess of 5 mm requires repairs or replacement of the sidewalk section(s) affected.

500.4.2.8.1 Measuring For Compliance

The Contractor shall undertake periodic inspections of sidewalks for evaluating the condition of all sidewalks within the Existing Infrastructure.

500.4.2.8.2 Completing Repairs

The Contractor shall complete repairs to restore the functionality of the sidewalk to the level for which it was originally designed. Repairs shall be completed within 180 days of the time when the Contractor knew of, or should have known of, the deficiency.

500.4.2.8.3 Payment Adjustments

Payment Adjustments for each instance where a sidewalk does not conform to the Technical Requirements, shall be \$1,000/occurrence/month or any partial month, until rectified.

500.4.3 TRAFFIC CONTROL DEVICES - OPERATION AND PERFORMANCE REQUIREMENTS

500.4.3.1 Signs

Signs shall be maintained such that they function as designed. The Contractor shall undertake the necessary maintenance to ensure that the desired message is available to motorists at all times. The following shall apply:

- Signing which does not function as designed shall be adjusted to meet the intended function;
- All signs shall be maintained to the physical size, materials, and lettering as designed and constructed for the original installation;
- Signs shall be kept clean and legible at all times;
- Signs shall have an acceptable level of retroreflectivity. Generally, acceptable retroreflectivity can be determined by visual examination of the sign under night-time driving conditions. Signs that exhibit reduced or blotchy retroreflectivity in excess of 25% of the sign area shall be considered to have unacceptable retroreflectivity. Sign reflectivity shall meet the requirements of ASTM D4956;
- Measurement of retroreflectivity will be determined in accordance with ASTM E1710 using a portable retroreflectometer;
- Sign posts shall be maintained straight and true and shall not lean more than 25 mm in 1 m in any direction;
- Signs shall be kept level, within 25 mm in 1 m, and properly orientated for the travelling public;
- All post replacement of mounted signs shall be the same type as the original installation;
- Galvanized or painted posts shall have the coating maintained such that no corrosion is visible;
- The maintenance of breakaway bases shall be conducted to meet the requirements of the design specifications;
- Signs or billboards containing advertising or for any commercial purpose are not permitted. The Contractor is responsible for the removal of all such signs/billboards; and
- The Contractor shall remove any non-conforming signs or any unauthorized signs from the Road Right of Way.

500.4.3.1.1 Measuring For Compliance

The Contractor shall conduct a regular monitoring program for evaluating the condition of all signs within the Existing Infrastructure.

500.4.3.1.2 Completing Repairs

The Contractor shall repair/replace any sign that is damaged, vandalized or which otherwise fails to meet the requirements of this Section 500.4.3 within the following timelines:

- Non-critical regulatory signs shall be repaired/replaced within 48 hours;
- Standard information/directional signs shall be repaired/replaced within 14 days; and
- Non-standard information/directional signs shall be repaired/replaced within 60 calendar days.

For straightening, or otherwise maintaining signs, the work shall be conducted within 21 days, unless the deficiency is such as to affect the effectiveness of the sign.

Unauthorized signs shall be removed within one day.

These time lines apply to the time elapsed from when the Contractor knew of, or should have known of, the deficiency with respect to any specification requirement in Section 500.4.3.

500.4.3.1.3 Payment Adjustments

Payment Adjustments shall be assessed against the Contractor for failing to maintain, repair/replace signs within the stipulated time as follows:

- General maintenance - \$100/sign/week for any whole or partial week the sign remains in need of maintenance;
- Repair or replacement of non-critical regulatory signs - \$1,000/sign/day or any partial day, until rectified;
- Repair or replacement of information signs $< 1 \text{ m}^2$ or failure to remove an unauthorized sign - \$100/sign/day or any partial day, until rectified; and
- Repair or replacement of information signs $\geq 1 \text{ m}^2$ - \$250/sign/day or any partial day, until rectified.

500.4.3.2 Traffic Signals

Traffic signals shall be maintained as designed and shall be fully operational at all times. The following shall apply:

- Signal lights, including any cross-walk lights or advance warning devices shall be maintained such that all lights function at all times;
- Electronics associated with signal operation and timing, etc. shall be maintained such that all signal operations are functioning at all times;
- Power supplies for signal installations shall be protected, maintained and serviced as required to ensure an uninterrupted power supply is available for signal operation at all times;
- Signal poles shall be maintained straight and true and shall not lean more than 10 mm in 1 m in any direction;
- Poles, control cabinets and other signal hardware shall be maintained such that no corrosion is visible and that corrosion does not affect the structural and operational integrity of any elements; and
- All repairs shall comply with the original design requirements.

500.4.3.2.1 Measuring For Compliance

The Contractor shall conduct a regular monitoring program for evaluating the condition of all traffic signals within the Existing Infrastructure.

500.4.3.2.2 Completing Repairs

The Contractor shall repair/replace any signals damaged, stolen, vandalized or which otherwise fail to meet the requirements of this Section 500.4.3.2 within the timelines as follows:

- For non-functioning signals, signing shall be installed immediately to direct traffic until signal function is restored;
- For all signals, repairs shall be undertaken immediately to restore the full functionality of the signal;
- For straightening signal standards, or otherwise maintaining signals, the work shall be conducted within 30 days, unless the deficiency is such as to affect the operation of the signal; and
- Corrosion remediation shall be carried out within 30 days.

A non-functional signal is defined as a signal location at which signal control is not available on any signal head for traffic from one (or more) directions.

The time lines apply to the time elapsed from when the Contractor knew of, or should have known of, the deficiency.

500.4.3.2.3 Payment Adjustments

Any period of non-operation, for any reason whatsoever, including power failure under the Contractor's control, shall result in a Payment Adjustment, following the expiration

of the specified time period for completing the specific repair, in accordance with the following:

- First occurrence of a non-functioning signal location - \$500/hour or any partial hour, until rectified;
- First occurrence of non-functioning bulb or colour display (maximum of one at a signal location) - \$100/day or any partial day, until rectified;
- First occurrence of non-functioning bulb or colour display (2 to 4 non-functioning lights or colour displays (provided no non-functioning two bulbs or colour display of the same type affects traffic in any single direction)) - \$200/day or any partial day, until rectified;
- First occurrence of mis-aligned signal pole - \$100/day or any partial day, until rectified; and
- Each occurrence to remediate corrosion within the specified time - \$100/occurrence/month or any partial month, until rectified.

Payment Adjustments for further occurrences of non-compliance following the first occurrence shall be twice the value shown above. In this section, “occurrence” refers to an occurrence anywhere on the Infrastructure.

The number of occurrences of non-compliance shall be determined for a consecutive 12 month period.

500.4.3.3 Pavement Markings

Pavement markings shall be maintained such that they function as designed. Pavement markings shall be maintained to achieve the following general objectives:

- To provide positive lane delineation for the safe and orderly movement of traffic on the Existing Infrastructure.
- To convey information to a vehicle operator without diverting the driver’s attention.
- To complement regulations or warnings by other devices such as traffic signals or signs.

All non-illuminated sections of roadway shall have markings with a minimum retroreflectivity of 100 mcd/lux/m² based on a minimum of five discreet measurements in any area of concern. All markings shall be maintained in a manner such that they are in proper repair, fully visible, complete and intact. Specifically but not exclusively, the Contractor shall ensure that:

- Dirt or debris which obscures the markings is removed;
- Breaks in markings caused by repair work, accident or any other reason, are reinstated;
- Markings comply with all design requirements and the following tolerances:

- Nominal 100 mm wide lines shall be applied to a tolerance of 100 mm to 110 mm;
- Nominal 200 mm line widths shall be applied to a tolerance of 200 to 210 mm;
- All direction dividing, lane dividing or continuity lines shall not exceed a maximum dimensional length deviation of +/- 100 mm for a specified 6.0 m or 3.0 m length of space; and
- All markings shall be applied at the proper location in accordance with the designed markings and in no case shall vary from the design location by more than 100 mm;
- All non-conforming markings are obliterated from the roadway; and
- Painted pavement markings shall exhibit:
 - No excessive (more than 10%) overspray;
 - No splattering of paint;
 - Clean definitive edges;
 - No more than five tracks per km;
 - Uniform distribution of glass beads across the line; and
 - Uniform thickness.

500.4.3.3.1 Measuring For Compliance

The Contractor shall inspect the Existing Infrastructure on a continual basis and will identify deficiencies related to general maintenance requirements. Deficient lines or markings will be measured and rounded up to the nearest full kilometre for the Payment Adjustment. Measurement of retroreflectivity of the pavement markings will be determined in accordance with ASTM Standard Test Method E1710 using a portable retroreflectometer.

500.4.3.3.2 Completing Repairs

Incorrect or confusing markings shall be removed immediately. This may involve remedial measures pending scheduling of permanent removal.

500.4.3.3.3 Payment Adjustments

If non-compliant markings are not re-installed to the required standard within the stipulated time period, Payment Adjustments of \$100 per marking/day or any partial day, shall be assessed until the markings are re-installed.

If incorrect or confusing markings are not removed within seven days, Payment Adjustments in the amount of \$100/marking/day or any partial day, shall be assessed until the repairs are made.

500.4.4 TESTING CONDUCTED WITH AN INERTIAL PROFILER

Once every three years, the Contractor shall measure the smoothness (IRI), and rutting of the Existing Infrastructure roadways, except all ramps and crossroads.

Measurements with the inertial profiler shall be in accordance with the requirements of the following sections. The measurements must be obtained after June 1st and before August 1st of the years the measurements are obtained:

- Section 400.4.2 (Pavement Geometric Requirements);
- Section 400.4.3 (Smoothness Requirements); and
- Section 400.4.4 (Rutting Performance Requirements).

The data collected for the inertial profiler shall be submitted to the Department on CD-ROM in accordance with the ASCII CSV file structure formats and file naming convention used by the Department.

All data collected by the Contractor is confidential and shall be turned over to the Department and shall become the property of the Department and may be used in any manner the Department deems appropriate. The Contractor may not use this data for any purpose nor shall the Contractor disseminate any information to any parties without the prior written approval of the Department.

500.4.4.1 Measuring For Compliance

Measurements with the inertial profiler must be collected during the same week from test year to test year. The profile measurements and IRI post-processing shall be submitted to the Department within three weeks of the collection of the field data.

500.4.4.2 Payment Adjustments

If the field measurements are not collected within the same week of the year in each testing year, the Contractor shall be assessed Payment Adjustments at a rate of \$2,000/week or any partial week, for each week in which the field measurements vary from the required week.

If the profile measurements and IRI post-processing is not submitted within the stipulated time period, the Contractor shall be assessed Payment Adjustments at a rate of \$500/week or any partial week, for each week that the information is not submitted.

500.5 BRIDGE STRUCTURES

500.5.1 GENERAL

During the Contractor's regularly scheduled inspections of the roadway and appurtenances as specified in Section 500.2 (Inspections, Emergency and Roadway Maintenance Requirements), the Contractor shall pay special attention to the condition, functionality and safe operation of the bridge structures. The Contractor shall ensure that qualified personnel carry out the regularly scheduled inspections. Any deficiencies that pose an imminent danger to the travelling public shall be addressed immediately.

In addition, regular scheduled bridge inspections as outlined in Section 500.5.3 (Performance Compliance Inspection and Testing) shall be completed by the Contractor to measure and determine compliance of the Existing Infrastructure bridge structures with the bridge structure performance requirements identified in Section 400.5.3 (Performance Requirements). The Contractor shall also carry out preventative bridge maintenance actions during the Operating Period.

500.5.2 UTILITY ACCOMMODATION

The Contractor shall accommodate utilities on the bridge structures when requested by the Department. All costs associated with the installation, maintenance and operation of the utilities shall be the responsibility of the utility owner.

During the Operating Period, the utility line may need to be removed or relocated to facilitate major maintenance, rehabilitation, replacement or closure of a bridge structure. Relocation or removal of the utility line, including all associated costs, shall be borne by the owner of the utility.

In the event that a utility line is no longer required, the utility owner shall advise the Department and the Contractor and arrange for the line to be removed and, when applicable, for the structure to be restored to the condition commensurate with that prior to the installation of the line.

500.5.3 PERFORMANCE COMPLIANCE INSPECTION AND TESTING

500.5.3.1 Inspections and Testing

All bridge structures of the Existing Infrastructure will be considered a component of the Provincial bridge structure inventory and as such will be subject to at least the same level of inspection as are all other bridge structures on the Provincial highway system.

The Contractor or its designated representative shall complete bridge inspection and testing of the bridge structures to measure and determine compliance to the performance requirements. The compliance inspection and testing shall be based on the Department's existing *Bridge Inspection and Maintenance (BIM) System*.

The BIM system consists of two levels of inspection. Level 1 inspections are routine inspections that are carried out on a regular inspection cycle and are primarily a visual inspection carried out without the use of specialized equipment for testing or for access. Level 2 inspections will also be carried out on a specified interval or on a one-time site-specific basis. Using specialized equipment and expertise, the Level 2 inspections gather detailed and quantified information and data on a particular bridge structure or bridge element.

500.5.3.1.1 Routine Level 1 Inspections

The Contractor shall complete routine Level 1 inspections in accordance with the Department's current *Bridge Inspection and Maintenance (BIM) System* to confirm that the performance requirements in Section 400.5.3 (Performance Requirements) are being met. Only qualified and experienced bridge inspectors that have a current Class A certification under the Department's BIM system shall complete the inspections.

The routine Level 1 bridge inspections will be completed at the prescribed cycle as follows:

- Initial inspection within 30 days of Traffic Availability; and
- Every 21 months after the initial inspection.

The routine inspection cycle may be shortened if deemed necessary by the inspector due to condition, functionality, use of the bridge structures or any other reason.

The Contractor shall complete each routine Level 1 inspection within the time period of one month prior to the originally scheduled date of the routine Level 1 inspection to one month following the originally scheduled date of the routine Level 1 inspection.

500.5.3.1.2 Specialized Level 2 Inspections

The Department currently carries out a number of specialized Level 2 inspections including concrete deck, copper sulphate electrode ("CSE") or half-cell testing, chloride ion content testing, ultrasonic inspection of steel elements, scour survey, steel culvert barrel measurement, timber coring, concrete girder, paint system and vertical clearance measurement.

The Contractor shall complete specialized Level 2 inspections in accordance with the schedule outlined in Section 200.3.6 (Level 2 Bridge Deck Inspections) to determine the condition of the concrete bridge decks of the Existing Infrastructure. The specialized

Level 2 deck inspections shall consist of concrete deck inspection, CSE testing and chloride ion content testing.

Only qualified and experienced bridge inspectors that have a current Class A certification under the Department’s BIM system shall complete the inspections.

The specialized Level 2 inspection and testing, except for the submission of inspection results, shall be completed between May 15 and September 15 of the testing year specified.

500.5.3.1.3 Inspection and Testing Notification

The Contractor shall notify the Department a minimum of two weeks in advance of the scheduled inspection and testing date and time. The Department may elect to have a representative on site during the Contractor’s scheduled inspection and testing. The Department also reserves the right to complete inspection or testing concurrently with the Contractor’s scheduled inspection and testing or at any other time. In the event the Department elects to complete inspection and testing concurrently with the Contractor’s scheduled inspection and testing, the Contractor shall provide the required traffic accommodation and assistance and cooperation.

The Department will use in-house or external engineering consultants to complete the inspection and testing on their behalf. Only qualified and experienced bridge inspectors that have a current Class “A” certification under the Department’s BIM system will perform the Department’s inspection and testing work.

500.5.3.1.4 Inspection Reporting

Within 30 days of the completion of a routine Level 1 bridge inspection and within 90 days of the completion of a specialized Level 2 bridge inspection and testing, the Contractor shall provide the results of the inspection and testing to the Department. In addition to the inspection and testing results, the Contractor shall submit a report identifying any components or elements found to be non-compliant with the performance requirements in Section 400.5.3 (Performance Requirements). Each identified deficiency will be categorized as structural and operational or standard maintenance in accordance with the requirements of Section 400.5.2 (Bridge Maintenance and Operations) along with the specified time period for commencement or completion of repair and/or remediation actions.

500.5.3.1.5 Payment Adjustments

In the event the Contractor fails to complete the scheduled inspection and testing requirements, including the submission of inspection results to the Department, the Department shall assess the following Payment Adjustments for late submission of inspection results:

- \$10,000/bridge/month or any partial month, for routine Level 1 inspections until submitted;
- \$20,000/bridge/year or any partial year, specialized Level 2 inspections until submitted.

500.5.3.2 Traffic Accommodation

The Contractor is expected to generally perform inspections and testing during non-peak traffic periods and on dates that cause a minimum of inconvenience to the travelling public.

The bridge inspection and testing may require inspectors and workers to be on or in close proximity to the roadway, making traffic accommodation necessary. The Contractor shall provide all necessary temporary signing and traffic accommodation for the duration of the inspection and testing at its own cost.

Lane Closure Payment Adjustments (see Section 500.1.6) shall be charged during inspection and testing carried out by the Contractor but not for audit testing and inspection carried out by the Department.

500.5.3.3 Measurement And Determination

The Department has made every effort to develop and use measurable and quantifiable performance requirements for the bridge structure elements. The BIM system minimizes the subjective nature of these evaluations through formal guidelines and extensive training and certification of inspection personnel.

500.5.4 BRIDGE MAINTENANCE AND OPERATIONS

500.5.4.1 General

The Contractor shall be required to carry out preventative maintenance actions on the bridge structures during the Operating Period. The Department will be responsible for the repair of all structural and operational (see description in Section 400.5.2.2) and standard maintenance (see description in Section 400.5.2.3) deficiencies.

The quality and standard of the maintenance, repair and rehabilitation actions are expected to be appropriate to ensure the 75 year service life of the bridge structures.

500.5.4.2 Preventative Bridge Structures Maintenance

The Contractor shall carry out a preventative bridge structures maintenance program for the duration of the Operating Period. The program shall include annual washings of the bridge decks, sealing of all bridge decks exposed to de-icing salts with an approved Type 1b sealer and sealing of all curbs with an approved Type 2a sealer. Sealing shall be carried out in accordance with the schedule outlined in Section 200.3.7 (Preventative Bridge Maintenance).

500.5.5 PAYMENT ADJUSTMENTS

In the event the Contractor fails to meet the specified schedule for preventative maintenance actions, the Department shall assess the following Payment Adjustments:

500.5.5.1 Preventative Bridge Structures Maintenance

In the event the Contractor fails to complete the scheduled Preventative Bridge Structures Maintenance (see Section 500.5.4.2), with the exception of annual bridge washings within the year scheduled, a Payment Adjustment of \$5,000/bridge/month or any partial month, shall be assessed until the Contractor completes the work.

In the event the Contractor fails to complete the annual bridge washings by June 1 of the year scheduled, a Payment Adjustment of \$5,000/bridge/month or any partial month, shall be assessed until the Contractor completes the work.

600.0 HANDBACK REQUIREMENTS

600.1 ROADWAY HANDBACK REQUIREMENTS - NEW INFRASTRUCTURE

At the end of the Term, when the Department assumes responsibility for the New Infrastructure, the roadway shall meet or exceed the following requirements:

600.1.1 CONDITION OF PAVEMENT

The pavements shall meet or exceed the following requirements:

- Cross-slope and superelevation <0.5% deviation from design rate;
- Pavement surface width shall not be less than design width*;
 - * Subject to the Payment Adjustment provisions in Section 400.4.2 (Pavement Geometric Requirements).

PAVEMENT SMOOTHNESS

Design Speed (kph)	IRI (mm/m) 1 km Average	IRI (mm/m) (100 m Section)
>110	1.9	2.9
>90 ≤110	2.0	3.0
>70 ≤90	2.2	3.2
≤70	2.4	3.4

- 1 km average rutting < 10 mm;
- 100 m section average rutting < 15 mm;
- Isolated area rutting < 25 mm;
- Minimum skid number (skid resistance) = 30; and
- Pavement Smoothness IRI Values shall be less than or equal to the numbers in the above table.

600.1.2 PAVEMENT SURFACE CONDITION

The pavement surface, including lanes and shoulders, shall be free of any evidence of structural weakness, pitting, potholes, ravelling, segregation, scaling, delamination, localized roughness and all other deficiencies. All cracks and joints shall be sealed with a sealant acceptable to the Department. The pavement surface shall be free and clear of dirt, sand and other debris.

600.1.3 STRUCTURAL REQUIREMENTS

At the time the Department assumes responsibility of the roadway, the structural capacity of each and every lane of the roadway shall be such that a rehabilitation design for 10 years of traffic loading will require no more than a 50 mm asphalt concrete overlay or equivalent treatment for the pavement type. The 10 year traffic loading will be determined based on traffic estimates at the time, but in no case will it exceed 10 million equivalent single axle loads for any lane of any section of roadway.

The rehabilitation needed for the requirement above will be determined by an independent consultant retained and paid for by the Department and acceptable to both the Department and the Contractor.

600.1.4 CONDITION OF ALL SIGNS

All signs on the New Infrastructure must be in-place and functioning as designed and shall meet or exceed the following:

- Have an acceptable level of retroreflectivity. No signs shall exhibit reduced or blotchy retroreflectivity in excess of 25% of the sign area;
- Regulatory signs shall have a minimum retroreflectivity of 250 cd/lux/m² at an observation angle of 0.2° and a light entry angle of -4°;
- Information signs shall have a minimum retroreflectivity of 170 cd/lux/m² at an observation angle of 0.2° and a light entry angle of -4°;
- Signs shall exhibit no sign-sheeting material delaminations from the sign blank;
- Sign posts shall be maintained straight and true and shall not lean more than 25 mm in 1 m in any direction;
- Signs shall be kept level, within 25 mm in 1 m, and properly orientated for the travelling public;
- Galvanized or painted posts shall have no visible corrosion; and
- All posts of mounted signs are of the same type.

600.1.5 CONDITION OF GUARDRAIL

All guardrail on the New Infrastructure must be installed and functioning as designed and meet or exceed the following:

- All guardrails shall be within 6 mm maximum for plumb and grade;
- All posts are sound and vertical; and
- All components shall be securely fastened with the designed fasteners.

600.1.6 CONDITION OF BARRIERS

All barriers on the New Infrastructure must be installed and functioning as designed and meet or exceed the following:

- All missing pieces and/or areas of structural weakening must be replaced.

600.1.7 CONDITION OF LIGHTING

All lighting systems and related components on the New Infrastructure must be installed and functioning as designed and meet or exceed the following:

- Poles shall be plumb within 10 mm in 1 m;
- Poles and other mounting hardware shall be clean and neat, with no structural corrosion and all visible corrosion areas are to be re-galvanized by methods approved by the Department;
- Concrete bases shall be structurally adequate for the design loads; and
- Each individual light/luminaire shall be operational, provide light output in accordance with the manufacturer's rated design parameters, and overall illumination in accordance with the Detailed Designs.

The Contractor shall cooperate with the Department to coordinate the transfer of supply of electrical power at the end of the Operating Period.

600.1.8 CONDITION OF TRAFFIC SIGNALS

All signal systems on the New Infrastructure must be installed and functioning as designed and meet or exceed the following:

- All signal lights, including any crosswalk lights or advance warning devices, shall be fully functional;
- Electronics associated with signal operation shall be fully functional;
- Signal poles shall be straight and true and shall not lean more than 10 mm in 1 m in any direction;
- Poles, control cabinets and other signal hardware shall have no structural corrosion and all visible corrosion areas are to be re-galvanized by methods approved by the Department; and
- Power supplies are protected and in good condition.

The Contractor shall cooperate with the Department to coordinate the transfer of supply of electrical power at the end of the Operating Period.

600.1.9 CONDITION OF THE DRAINAGE SYSTEM

All components of the drainage system on or related to the New Infrastructure must be installed and functioning as designed. Culverts shall have no perforations. Any perforated culvert shall be replaced or lined as directed by the Department. All ditches, culverts, storm sewers, manholes, inlet and outlet structures, stormwater management ponds and other appurtenances shall be fully operational and clear of any debris or accumulated material.

600.1.10 CONDITION OF CONCRETE CURBS, GUTTERS, SIDEWALKS, BARRIERS (NON-STRUCTURE RELATED)

All concrete infrastructure on the New Infrastructure must be installed and functioning as designed and meet or exceed the following:

- Broken, spalled or damaged concrete shall be replaced where required to restore functionality;
- Curb height shall meet the requirements of the design specifications and in no case shall be less than 150 mm;
- Differential elevation at joints or cracks that exceeds 5 mm shall be repaired or replaced to remove the differential elevation and remove any tripping hazard;
- Concrete that is cracked in multiple locations within the same general area of a sidewalk or otherwise results in a discontinuity that may pose a tripping hazard or be a safety concern shall be removed and replaced; and
- Concrete surfaces that exhibit scaling and results in a rough surface texture shall be removed and replaced.

600.1.11 CONDITION OF LANDSCAPING

All lands disturbed by the Contractor shall have been reclaimed and Reclamation Certificates obtained prior to handback.

All landscaping on the New Infrastructure must be in place and functioning as designed and meet or exceed the following:

- There are no bare spots greater than one square metre in size;
- There is a minimum of 80% ground cover for any 100 square metre area;
- No noxious weeds are present; and
- Grass in the Road Right of Way shall not exceed 300 mm in height.

600.1.12 CONDITION OF FENCING

All fencing on the New Infrastructure must be installed and functioning as designed and meet or exceed the following:

- All posts must be sound and vertical;
- All wires must be in place with no noticeable sag; and
- All gates must be in place and fully operational.

600.1.13 CONDITION OF PAVEMENT MARKINGS

All pavement markings on the New Infrastructure must be installed and functioning as designed and meet or exceed the following:

- All non-illuminated sections of roadway shall have markings with a minimum retroreflectivity of 150 mcd/lux/m² based on a minimum of five discrete measurements in any area of concern;
- Nominal 100 mm wide markings shall be within a tolerance of 100 mm to 110 mm;
- Nominal 200 mm wide markings shall be within a tolerance of 200 to 210 mm;
- All direction dividing, lane dividing or continuity markings shall not exceed a maximum dimensional length deviation of +/- 100 mm for a specified 6.0 m or 3.0 m length of space;
- All markings shall be at the proper location in accordance with the designed markings and in no case shall vary from the design location by more than 100 mm; and
- All painted markings shall display the following:
 - No excessive (more than 10%) overspray;
 - No splattering of paint;
 - Clean definitive edges;
 - No more than five tracks per km; and
 - Uniform distribution of glass beads across the line.

600.1.14 CONDITION OF ROAD TRAFFIC NOISE MITIGATION

All road traffic noise mitigation elements by the Contractor's design on the New Infrastructure shall be installed and functioning as designed and meet or exceed the following:

- Road traffic noise as measured in accordance with Section 200.2.14 (Noise Attenuation) shall not exceed 65 dBA Leq₂₄.

600.1.15 CONDITION OF DELINEATORS

All delineators on the New Infrastructure shall be installed and functioning as designed and meet or exceed the following:

- Delineators shall exhibit a minimum retroreflectivity of 80% of the design value;
- Delineator guideposts shall be plumb within 13 mm throughout their length; and
- Delineators shall be within 5% of design height and not deviate from design locations by more than 50 mm.

600.2 BRIDGE STRUCTURES HANDBACK REQUIREMENTS - NEW INFRASTRUCTURE

600.2.1 GENERAL

At the end of the Operating Period, the bridge structures shall be turned back to the Department. The structures shall be in adequate condition and function as designed with no loss of structural strength and shall meet the handback performance requirements at the end of the Term. The Contractor shall complete any required maintenance or rehabilitation prior to the end of the Term to meet the required functionality state and handback condition prior to returning the bridge structures to the Department's control and management.

Notwithstanding the handback performance requirements stated in this section and Sections 400.5.3.2 (Individual Component Requirements – Bridges), 400.5.3.3 (Individual Component Requirements – Bridge Culverts) and 400.5.3.4 (Individual Component Requirements – Sign Structures), all individual components rated 4 or less under the Department's *Bridge Inspection and Maintenance (BIM) System* shall be considered in non-conformance.

600.2.2 INDIVIDUAL COMPONENT REQUIREMENTS - BRIDGES

With the exception of Section 600.2.2.1 (Concrete Bridge Decks), bridges shall meet the performance requirements specified in Section 400.5.3.2 (Individual Component Requirements – Bridges) at the end of the Term.

Concrete bridge decks shall meet the performance requirements stated in Section 600.2.2.1 (Concrete Bridge Decks) at the end of the Term.

600.2.2.1 Concrete Bridge Decks

Unless noted otherwise the bridge deck shall not have any physical defects or chemical deterioration.

Concrete bridge decks cast-to-grade shall not have any cracks greater than 0.1 mm in width and a linear measurement of 0.2 m of cracking per square metre of bridge deck area.

The underside of all concrete decks shall be free of stains resulting from deterioration, efflorescence and exudation.

Any cracking on the deck underside shall be limited to a maximum width of 0.3 mm.

The following handback performance requirements for specialized Level 2 inspections shall be met for the Department’s standard deck protection system as identified in Section 300.5.2 (Bridge Structures – Design Criteria).

Year 30 of the Operating Period

CSE test results showing a minimum of 75% of deck area with reading less negative than –0.300 mV.

Maximum total average chloride content of 0.025, by percent weight, at the top mat of reinforcing or 100 mm depth, whichever is less.

The deck area shall not be delaminated or debonded as determined by chain drag testing.

Deck testing shall be carried out in accordance with the requirements of the Department’s *Level 2 Bridge Inspection Manual*.

The copper sulphate electrode testing is based on the ASTM C876 method with some minor differences. The method for CSE testing is outlined in the Department’s BT009-March 98 “*Test Procedure for Evaluating Corrosion of Reinforcing Steel in Bridge Decks.*”

Chloride content testing is performed in accordance with the “*Standard Test Method for Chloride Content in Concrete Using the Specific Ion Probe*” as described in SHRP-S-330, Appendix F, “*The Method of Field Determination of Total Chloride Content*” as described in SHRP-S-328, Volume 6 or an approved equivalent test method such as Alberta Transportation Test Method TLT 520.

For alternative deck protection systems the Contractor shall identify the performance criteria to be met by the concrete bridge deck at Year 30. This performance criteria shall be set to ensure that the maximum average total chloride content at the level of the deck rebar is below the deck rebar’s corrosion threshold.

**600.2.3 INDIVIDUAL COMPONENT REQUIREMENTS – BRIDGE
CULVERT STRUCTURES**

Bridge culvert structures shall meet the handback performance requirements specified in Section 400.5.3.3 (Individual Component Requirements – Bridge Culverts) at the end of the Term.

**600.2.4 INDIVIDUAL COMPONENT REQUIREMENTS - SIGN
STRUCTURES**

Overhead and cantilever sign structures shall meet the handback performance requirements specified in Section 400.5.3.4 (Individual Component Requirements – Sign Structures) at the end of the Term.

600.3 ROADWAY HANDBACK REQUIREMENTS - EXISTING INFRASTRUCTURE

At the end of the Term, when the Department assumes responsibility for the Existing Infrastructure, the roadway shall meet or exceed the following requirements:

600.3.1 PAVEMENT SURFACE CONDITION

The pavement surface, including lanes and shoulders, shall be free of pitting, potholes, ravelling, scaling, delamination, localized roughness, localized deficiencies, and other deficiencies.

- All asphalt concrete pavement transverse and random cracks between 2 mm and 25 mm and all longitudinal cracks between 2 mm and 12 mm shall be routed and sealed. Transverse cracks greater than 25 mm and longitudinal cracks greater than 12 mm shall be spray patched.
- All Portland cement concrete random cracks between 2 mm and 20 mm in width shall be sawn/routed and sealed, and sawn/routed cracks missing sealant shall be re-sealed.
- Areas of localized roughness are to be repaired. Localized roughness shall be any abrupt deviation in excess of 6 mm when measured with a 1.2 m straight edge.
- Roadway surface shall be clean and free of dirt, sand and other debris.
- All cracks shall be sealed with a sealant acceptable to the Department.

600.3.2 CONDITION OF ALL SIGNS

All signs on the Existing Infrastructure must be in-place and functioning as designed and shall meet or exceed the following:

- Have an acceptable level of retroreflectivity. No signs shall exhibit reduced or blotchy retroreflectivity in excess of 25% of the sign area;
- Regulatory signs shall have a minimum retroreflectivity of 250 cd/lux/m² at an observation angle of 0.2° and a light entry angle of -4°;
- Information signs shall have a minimum retroreflectivity of 170 cd/lux/m² at an observation angle of 0.2° and a light entry angle of -4°;
- Signs shall exhibit no sign-sheeting material delaminations from the sign blank;
- Sign posts shall be maintained straight and true and shall not lean more than 25 mm in 1 m in any direction; and
- Signs shall be kept level, within 25 mm in 1 m, and properly orientated for the travelling public.

600.3.3 CONDITION OF GUARDRAIL

- All accident damaged guardrail on the Existing Infrastructure must be repaired or replaced and functioning as designed; and
- All guardrails shall be clean and any reflective markers shall be functioning as designed.

600.3.4 CONDITION OF BARRIERS

- All accident damaged barriers on the Existing Infrastructure must be repaired or replaced and functioning as designed; and
- All barriers shall be clean and any reflective markers shall be functioning as designed.

600.3.5 CONDITION OF LIGHTING

All lights/luminaires on the Existing Infrastructure must be installed and functioning as designed and meet or exceed the following:

- Accident damaged lighting system components must be repaired/replaced and be functioning as designed; and
- Each individual light/luminaire shall be operational, provide light output in accordance with the manufacturer's rated design parameters, and overall illumination in accordance with the Detailed Designs.

600.3.6 CONDITION OF TRAFFIC SIGNALS

All signal systems on the Existing Infrastructure must be functioning as designed and meet or exceed the following:

- All signal lights, including any crosswalk lights or advance warning devices, shall be fully functional;
- Electronics associated with signal operation shall be fully functional;
- Signal poles shall be straight and true and shall not lean more than 10 mm in 1 m in any direction; and
- Power supplies are protected and in good condition.

600.3.7 CONDITION OF THE DRAINAGE SYSTEM

All components of the drainage system on or related to the Existing Infrastructure must be functioning as designed. All ditches, culverts, storm sewers, manholes, inlet and outlet structures, stormwater management ponds and other appurtenances shall be fully operational and clear of any debris and accumulated material.

600.3.8 CONDITION OF CONCRETE CURBS, GUTTERS, SIDEWALKS, BARRIERS (NON-STRUCTURE RELATED)

All concrete infrastructure on the Existing Infrastructure installed by the Contractor must be functioning as designed and meet or exceed the following:

- Broken, spalled or damaged concrete shall be replaced where required to restore functionality;
- Differential elevation at joints or cracks that exceeds 5 mm shall be repaired or replaced to remove the differential elevation and remove any tripping hazard;
- Concrete that is cracked in multiple locations within the same general area of a sidewalk or otherwise results in a discontinuity that may pose a tripping hazard or be a safety concern shall be removed and replaced; and
- Concrete surfaces that exhibit scaling and results in a rough surface texture shall be removed and replaced.

600.3.9 CONDITION OF LANDSCAPING

All landscaping on the Existing Infrastructure must be in place and functioning as designed and meet or exceed the following:

- Grass within the Road Right of Way does not exceed 300 mm in height;
- No noxious weeds are present; and
- Seeded area shows no bare spots greater than 1 m² in size.

600.3.10 CONDITION OF FENCING

All fencing on the Existing Infrastructure must be installed and functioning as designed and meet or exceed the following:

- All posts must be sound and vertical;
- All wires must be in place with no noticeable sag; and
- All gates must be in place and fully operational.

600.3.11 CONDITION OF PAVEMENT MARKINGS

All pavement markings on the Existing Infrastructure must be installed and functioning as designed and meet or exceed the following:

- All pavement markings shall have a minimum retroreflectivity of 150 mcd/lux/m² based on a minimum of five discreet measurements in any area of concern;
- Nominal 100 mm wide markings shall be within a tolerance of 100 mm to 110 mm;
- Nominal 200 mm wide markings shall be within a tolerance of 200 to 210 mm;
- All direction dividing, lane dividing or continuity markings shall not exceed a maximum dimensional length deviation of +/- 100 mm for a specified 6.0 m or 3.0 m length of space;
- All markings shall be at the proper location in accordance with the designed markings and in no case shall vary from the design location by more than 100 mm; and
- All painted markings shall display the following:
 - No excessive (more than 10%) overspray;
 - No splattering of paint;
 - Clean definitive edges;
 - No more than five tracks per km; and
 - Uniform distribution of glass beads across the line.

600.3.12 CONDITION OF DELINEATORS

All delineators on the Existing Infrastructure shall be installed and functioning as designed and meet or exceed the following:

- Delineators shall exhibit a minimum retroreflectivity of 80% of the design value;
- Delineator guideposts shall be plumb within 13 mm throughout their length; and
- Delineators shall be within 5% of design height and not deviate from design locations by more than 50 mm.

**600.4 BRIDGE STRUCTURES HANDBACK REQUIREMENTS - EXISTING
INFRASTRUCTURE**

At the end of the Term, maintenance and operations responsibilities for the bridge structures shall be turned back to the Department. There are no handback requirements for bridge structures in the Existing Infrastructure at the end of the Term.

**APPENDIX A -
DRAWINGS**

**Drawings: 18-A-01
18-A-02
18-A-03
18-A-04
18-A-05
18-A-06
18-A-07
18-A-08
18-A-09
18-A-10
18-A-11
18-A-12
18-A-13
18-A-14
18-A-15a
18-A-15b
18-A-16a
18-A-16b
18-A-17
18-A-18
18-A-19
18-A-20
18-A-21a
18-A-21b
18-A-22
18-A-23a
18-A-23b
18-A-24
18-A-25
18-A-26
18-A-27
18-A-28
18-A-29
18-A-30
18-A-31
18-A-32
18-A-33
18-A-34
18-A-35**

**APPENDIX B -
PAYMENT ADJUSTMENT SUMMARY**

**INTENTIONALLY DELETED AND REPLACED WITH
SCHEDULE 15 (PAYMENT ADJUSTMENTS SUMMARY)**

APPENDIX C - REPORTING SUMMARY

1. GENERAL

1.1 Section References

References to section numbers in this Appendix C are to section numbers of the Technical Requirements.

1.2 Priority

In the event of any inconsistency between the listing of, criteria for and the descriptions of the reporting obligations set out in the body of Schedule 18 and the listing of such criteria included in this Appendix C, the more detailed provisions of the body of Schedule 18 shall govern.

2. REPORTING

The following is a summary of the reporting requirements set out in the Technical Requirement:

Guide Signing (Overhead) (Section 200.2.7)

General Design Documentation (Section 300.2.3)

Reclamation Certificates (Section 300.3.1)

As-Built Construction Reports (Section 300.3.3)

Geotechnical Reports (Section 300.4.1.3)

Pavement Design Report (Section 300.4.1.8.1)

Bridge Structures Design Report Requirements (Section 300.5.3)

Bridge Structures Final Design Report Requirements (Section 300.5.4)

Cast-In-Concrete – Submissions (Section 300.5.7.2)

Class HPC and Class HPC with Steel Fibres (Section 300.5.7.5.2)

Structural Steel – Submissions (Section 300.5.8.2)

Engineering Data (Section 300.5.8.3.3)

Fabrication (Section 300.5.8.4.2)

Bridge Girders (Section 300.5.8.5.2)

Precast Concrete Units – Submissions (Section 300.5.9.2)

Post-Tensioning – Submissions (Section 300.5.9.10.12.2)

Construction (Section 300.5.9.10.12.7)

Construction of CSP and SPCSP Structures – Submissions (Section 300.5.10.2)

Sign Structures – Submissions (Section 300.5.12.2)

Piling (Section 300.5.13)

Rehabilitation As-Built Construction Reports (Section 400.1.2)

Daily Road Reports (Sections 400.2.1.2 and 500.2.1.2)

Emergency Maintenance Reporting Procedures (Sections 400.2.6 and 500.2.6)

Snow Clearing and Ice Control Operations Plan (Sections 400.3.1 and 500.3.1)

Winter Maintenance Operations Requirements Reporting (Section 400.3.3.1 and 500.3.3.1)

Preferential Bridge Deck Icing Occurrence (Sections 400.3.4.1 and 500.3.4.1)

Weed Control Reporting (Sections 400.4.7.4.2.1 and 500.4.2.4.2.1)

Bridges Structures Inspection/Testing Notification and Inspection Reporting (Sections 400.5.1.3.4, 400.5.1.3.5, 500.5.3.1.3, and 500.5.3.1.4)

Bridge Structure Maintenance and Rehabilitation Requirements Notification and Reporting (Sections 400.5.2.6 and 400.5.2.7)

Testing Conducted with an Inertial Profiler Reporting (Section 500.4.4)

**APPENDIX D -
HISTORICAL RESOURCES ACT (ALBERTA)
CLEARANCE LETTER**

**APPENDIX E -
GUIDE SIGNING FOR NEW INFRASTRUCTURE**

**Drawings: 18-E-1
18-E-2
18-E-3
18-E-4
18-E-5
18-E-6
18-E-7
18-E-8**

APPENDIX F

LIST OF ACRONYMS

AAR:	Alkali-Aggregate Reactivity
AADT:	Average Annual Daily Traffic
AASHTO:	American Association of State Highway and Transportation Officials
ACI:	American Concrete Institute
ACP:	Asphalt Concrete Pavement
AGC:	Associated General Contractors
AHDGA:	American Hot Dip Galvanizers Association
AISI:	American Iron and Steel Institute
AMA:	Alberta Motor Association
ANSI:	American National Standards Institute
APEGGA:	Association of Professional Engineers, Geologists and Geophysicist of Alberta
ARTBA:	American Road and Transportation Builders Association
ASCII:	American Standard Code for Information Interchange
AWS:	American Welding Society
ASTM:	American Society for Testing and Materials
BIM:	Bridge Inspection and Maintenance
CAP:	Corrugated Aluminum Pipe
CEAA:	Canadian Environmental Assessment Act
CECAB:	Canadian Environmental Certification Appeals Board
CGSB:	Canadian General Standards Board
CN:	Canadian National Railway Company
CP:	Canadian Pacific Railway Limited
CSA:	Canadian Standards Association
CSE:	Copper Sulphate Electrode
CSP:	Corrugated Steel Pipe
CSV:	Comma Separated Value
CTA:	Canada Transportation Act
CWB:	Canadian Welding Bureau
DCMS:	Dynamic Changeable Message Signs
DD:	Design Data

DFO:	Department of Fisheries and Oceans
DFT:	Dry Film Thickness
ESAL:	Equivalent Single Axle Load
EEMAC:	Electrical and Electronic Manufacturer's Association of Canada
EMS:	Environmental Management System
HERP:	Herbicide Exemption Request Program
ICP:	Inductively Coupled Plasma Spectrometry
IFI:	International Friction Index
IMU:	Inertial Measurement Unit
IRCA:	International Register for Certificated Auditors
IRI:	International Roughness Index
ISL:	Infrastructure Systems Limited
ISO:	International Standards Organization
Leq ₂₄ :	Weighted 24 hour equivalent sound level
LRFD:	Load and Resistance Factor Design
MAPP:	Medical Alert Pesticide Program
MSE:	Mechanically Stabilized Earth
MTO:	Ministry of Transportation Ontario
NCHRP:	National Cooperative Highway Research Program
NEMA:	National Electrical Manufacturers Association
NQI:	National Quality Institute
NWPA:	Navigable Waters Protection Act
OSCAM:	On-Street Construction and Maintenance
PDF:	Portable Document Format
PG:	Performance Grade
PTFE:	Polytetrafluoroethylene
PTI:	Post Tensioning Institute
PVC:	Polyvinyl Chloride
QMS:	Quality Management System
RAP:	Reclaimed Asphalt Pavement
RAB:	Registrar Accreditation Board
RWIS:	Road Weather Information System
SHRP:	Strategic Highway Research Program
SPCSP:	Structural Plate Corrugated Steel Pipe
SSPC:	Society for Protective Coating Standards
TAC:	Transportation Association of Canada

**APPENDIX G -
ALBERTA INFRASTRUCTURE AND TRANSPORTATION
LAND LEASE SUMMARY AND DRAWINGS**

- **Table (Pages 1 and 2)**
- **“Calgary Transportation and Utility Corridor Northeast Stony Trail Leases” Drawings – Overall Plan and Sheet Numbers 1 to 7 inclusive**

**APPENDIX H -
AUTOMATIC TRAFFIC RECORDER (ATR)
SPECIFICATIONS**

**APPENDIX I –
ROAD WEATHER INFORMATION SYSTEM – Drawing 18-
I-01**