

BAR LIST — Pier 0° Skew							
MARK	SIZE	NO	TYPE	"X"	"Y"	LENGTH	WEIGHT
B401	4	33	B			8'-4"	184
B402	4	33	C			5'-2"	70
B501	5	12	A	31'-8"		54'-2"	1354
B702	7	60	Str.			4'-0"	491
B701	7	20	Str.			2'-4"	95
B501	5	10	D	1'-9"		5'-9"	60
B403	4	2	Str.			31'-8"	42
B703	7	40	Str.			3'-0"	245
Total lbs.:							2,561

BAR LIST — Pier 15° Skew							
MARK	SIZE	NO	TYPE	"X"	"Y"	LENGTH	WEIGHT
B401	4	34	B			8'-4"	189
B402	4	34	C			5'-2"	72
B501	5	12	A	32'-8"		55'-2"	1435
B702	7	60	Str.			4'-0"	491
B701	7	20	Str.			2'-4"	95
B501	5	10	D	1'-9"		5'-9"	60
B403	4	2	Str.			32'-8"	44
B703	7	40	Str.			3'-0"	245
Total lbs.:							2,631

BAR LIST — Pier 33° Skew							
MARK	SIZE	NO	TYPE	"X"	"Y"	LENGTH	WEIGHT
B401	4	36	B			8'-4"	212
B402	4	36	C			5'-2"	80
B501	5	12	A	34'-8"		59'-2"	1598
B702	7	60	Str.			4'-0"	491
B701	7	20	Str.			2'-4"	95
B501	5	10	D	1'-9"		5'-9"	60
B403	4	2	Str.			35'-8"	48
B703	7	40	Str.			3'-0"	245
Total lbs.:							2,830

BAR TYPES :
(All dimensions are cut to fit)

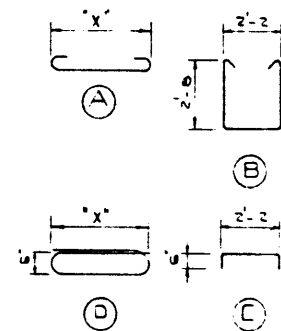

GENERAL NOTES :

- All requirements of the Bridge Branch Specification for the Supply of Structural Steel for Bridges (Specification No. 8187-64) shall be met, except that no shop paint shall be applied to pipe piles and 6" along edges of pier webs.
- All welding shall conform to A.W.S. Specification. When temperature is below 32°F preheat the base metal to at least 200°F for 3" both laterally and in advance of the welding. Welding shall not be done when the temperature is lower than 0°F unless protection is provided for the operator and the enclosure is heated to at least 70°F.
- Painting Specification: Pier webs shall receive one coat of primer in the shop and two finish coats in the field. Pipe piles and 6" along edges of pier webs shall receive one coat of primer and two finish coats all applied in the field. Primer shall conform to CGS Spec 1-GP-166A Type III and shall have a dry thickness of 1.5 to 2.5 mils. Before painting, all steel shall be sandblasted in accordance with SSPC-SP-6-63 T of the Steel Structures Painting Council. Pipe piles shall be sandblasted after pier webs have been installed. Painting shall not commence until approval of the cleaning has been obtained from the Engineer.
- Steel for pier webs shall meet A.S.T.M. A36 or CSA 0.12.
- 20" x 20" pipe piles shall be driven to elevations shown in General Layout or to the following bearing values when bearing capacity is determined by a bearing formula.

Span Length (ft.)	35	40	45	50	55	60
Bearing capacity (tons)	60	60	65	70	70	75
- Concrete shall be of standard weight aggregate with a maximum size of 3/4". Minimum compressive strength shall be 4000 p.s.i. at 28 days. Air entrainment shall be not less than 5%. Units are to conform to the requirements of the Bridge Branch Specifications for Manufacture of Precast Concrete Units, 8-19-64.
- Pier caps shall be supported on top or bottom surface at points indicated during hauling.
- All exposed corners to have 3/8" fillet or chamfer.
- All concrete surfaces except top of pier cap shall be given a Class Finish. Top of pier cap to be Class 1.
- All reinforcing steel shall have 2" clear cover unless otherwise noted.
- Pier cap shall be plant cast in a single unit.
- Neoprene bearing pads:
 - 0° skew - 18" x 3/8" x 3/2"-3, 50 Hardness
 - 15° skew - 18" x 3/8" x 3/2"-3, 60 Hardness
 - 30° skew - 18" x 3/8" x 3/2"-3, 60 Hardness
- Weight of precast pier caps:
 - 0° skew - 30.0 kips
 - 15° skew - 37.1 kips
 - 30° skew - 41.4 kips

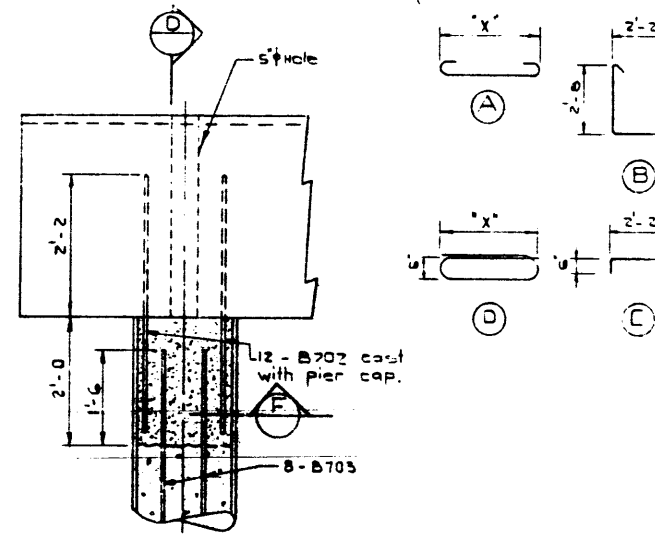

PART ELEVATION

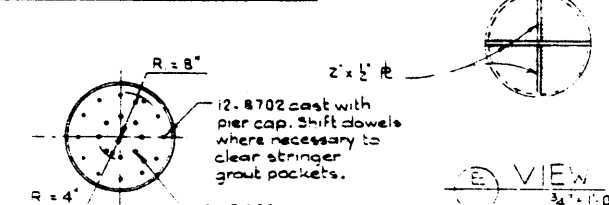

SECTION E

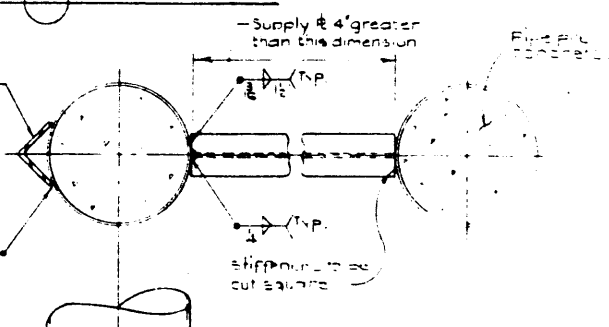

SECTION F

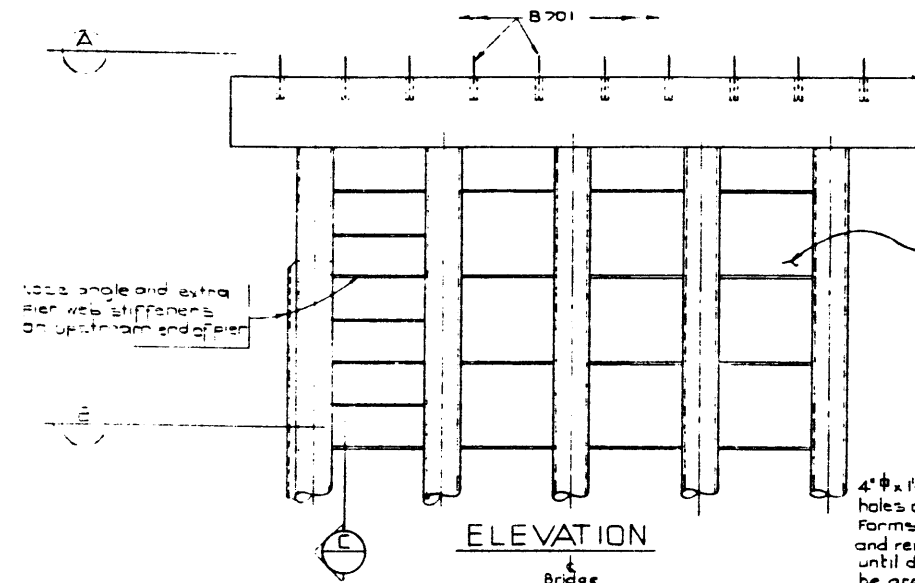

ELEVATION

Dowel Grout Hole Spacing - $3 \times 3'-0"4 = 27'-2\frac{1}{4}$

Column Spacing - $4 \times 6'-0" = 24'-0$

Point of support for lifting and hauling.

Column Spacing - $4 \times 6'-3" = 25'-0$

Dowel Grout Hole Spacing - $3 \times 3'-1\frac{1}{2} \text{ (approx.)} = 28'-1\frac{1}{2}$

Column Spacing - $4 \times 6'-3" = 25'-0$

Dowel Grout Hole Spacing - $9 \times 3'-5\frac{1}{2} = 31'-4\frac{1}{2}$

Column Spacing - $4 \times 7'-1\frac{1}{2} = 28'-6$

Dowel Grout Hole Spacing - $9 \times 3'-5\frac{1}{2} = 31'-4\frac{1}{2}$

Column Spacing - $4 \times 7'-1\frac{1}{2} = 28'-6$

Dowel Grout Hole Spacing - $9 \times 3'-5\frac{1}{2} = 31'-4\frac{1}{2}$

Column Spacing - $4 \times 7'-1\frac{1}{2} = 28'-6$

Dowel Grout Hole Spacing - $9 \times 3'-5\frac{1}{2} = 31'-4\frac{1}{2}$

Column Spacing - $4 \times 7'-1\frac{1}{2} = 28'-6$

Dowel Grout Hole Spacing - $9 \times 3'-5\frac{1}{2} = 31'-4\frac{1}{2}$

Column Spacing - $4 \times 7'-1\frac{1}{2} = 28'-6$

Dowel Grout Hole Spacing - $9 \times 3'-5\frac{1}{2} = 31'-4\frac{1}{2}$

Column Spacing - $4 \times 7'-1\frac{1}{2} = 28'-6$

Dowel Grout Hole Spacing - $9 \times 3'-5\frac{1}{2} = 31'-4\frac{1}{2}$

Column Spacing - $4 \times 7'-1\frac{1}{2} = 28'-6$

TOP PLANS

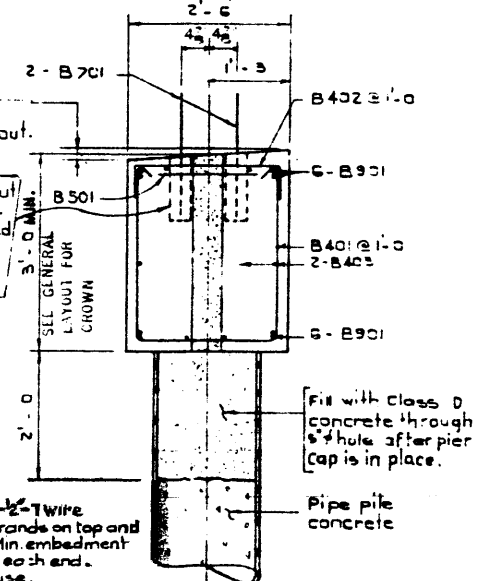

SECTION C

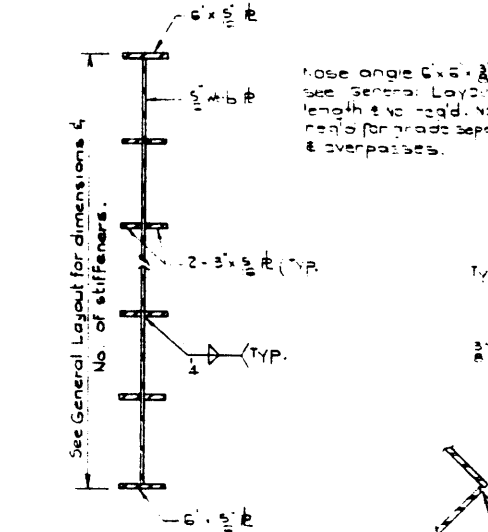

SECTION D

Use angle and extra pier web stiffeners on upstream end of pier.

See General Layout for dimensions & elevations of steel webs. Not req'd for grade separations & railway overpasses.

For pier cap level see General Layout.

4" x 1'-0" dowel grout holes cast into seat. Forms are to be capped and remain sealed until dowels are to be grouted.

Fill with Class D concrete through 5" hole after pier cap is in place.

Pipe pile concrete.

20" Pipe pile, 20" wall thickness.

Use angle 6"x6" & see General Layout for length & req'd. Not req'd for grade separations & overpasses.

ERECTION PROCEDURE

1. Drive pipe.
2. Realign pipe if necessary.
3. Cut off pipe piles.
4. Fill pipe piles to 2' below top with pipe pile concrete.
5. Place cap.
6. Check for slope and position of cap.
7. Adjust cap if necessary by skimming.
8. Pour to 2' of pipe pile through hole in cap.
9. Clean up junction of pile and cap if necessary.

DATE 11 19 19
DESIGNED BY
DATE
DETAILED BY
DATE
CHECKED BY

STANDARD TYPE M BRIDGE
27' ROADWAY, 14.8° SKEW
PIER

GOVERNMENT OF THE PROVINCE OF ALBERTA
DEPARTMENT OF HIGHWAYS AND TRANSPORT
BRIDGE BRANCH EDMONTON

NO.	DATE	DESCRIPTION	BY

PL. NO. HWY. NO. DWS. NO.
LOCATION SCALE SHEET OF 5-1031