

| BAR LIST: Scale House Foundation | | | | | | | |
|----------------------------------|------|-----|------|------|------|--------|--------|
| Mark | Size | No. | Type | X | Y | Length | Weight |
| D 301 | 3 | 16 | str. | | | 22'-3 | 134 |
| D 302 | | 19 | str. | | | 23'-5 | 157 |
| D 303 | | 4 | str. | | | 8'-0 | 12 |
| D 304 | | 11 | M | | | 7'-0 | 29 |
| D 305 | 3 | 6 | str. | | | 16'-3 | 37 |
| T 401 | 4 | 45 | K | 1-3 | 1-3 | 2'-6 | 75 |
| V 401 | 4 | 73 | str. | | | 4'-10 | 256 |
| V 402 | | 14 | | | | 24'-3 | 227 |
| V 403 | | 7 | | | | 23'-5 | 189 |
| V 404 | | 5 | | | | 14'-7 | 49 |
| V 405 | | 12 | | | | 8'-11 | 71 |
| V 406 | | 5 | str. | | | 4'-10 | 16 |
| F 401 | | 51 | A | | | 2'-7 | 88 |
| F 402 | | 7 | B | 4-10 | 1-5 | 7'-8 | 36 |
| F 403 | | 6 | C | | | 7'-11 | 32 |
| F 404 | 4 | 4 | B | 14-7 | 1-5 | 17'-5 | 47 |
| F 301 | 3 | 6 | J | 1-10 | 2-4 | 7'-6 | 17 |
| F 303 | 3 | 2 | F | 1-11 | 1-11 | 8'-8 | 7 |
| H 601 | 6 | 4 | str. | | | 12'-0 | 72 |
| H 401 | 4 | 12 | H | 1-1 | | 1'-11 | 15 |
| D 504 | 5 | 4 | str. | | | 35'-0 | 146 |
| Total Lbs. : 1,622 | | | | | | | |

| BAR LIST: Scale Pit, 1-Remote Display (2-Lamp Bases) | | | | | | | |
|--|------|-----|------|-------|------|--------|--------|
| Mark | Size | No. | Type | X | Y | Length | Weight |
| P 301 | 3 | 2 | D | 2'-8 | 2'-8 | 11'-4 | 9 |
| P 302 | 3 | 4 | I | 2'-8 | 3'-5 | 12'-10 | 19 |
| P 303 | 3 | 6 | | 2'-2 | 2'-8 | 10'-4 | 23 |
| P 304 | 3 | 2 | | 4'-0 | 2'-8 | 14'-0 | 11 |
| P 305 | 3 | 4 | | 4'-0 | 4'-3 | 17'-2 | 26 |
| P 306 | 3 | 1 | | 1'-10 | 2'-8 | 9'-8 | 4 |
| P 307 | 3 | 2 | | 1'-10 | 4'-3 | 12'-10 | 10 |
| P 308 | 3 | 2 | | 3'-0 | 2'-8 | 12'-0 | 9 |
| P 309 | 3 | 4 | I | 3'-0 | 3'-5 | 13'-6 | 20 |
| P 310 | 3 | 4 | D | 2'-2 | 4'-3 | 15'-6 | 28 |
| P 311 | 3 | 6 | E | 2'-2 | | 3'-0 | 7 |
| P 312 | 3 | 16 | E | 2'-8 | | 3'-6 | 21 |
| P 313 | 3 | 10 | E | 5'-8 | | 6'-6 | 24 |
| F 304 | 3 | 4 | F | 5'-9 | 2'-5 | 16'-10 | 25 |
| F 305 | 3 | 6 | J | 2'-4 | 4'-2 | 11'-8 | 26 |
| F 306 | 3 | 3 | J | 5'-8 | 4'-2 | 15'-0 | 17 |
| F 307 | 3 | 6 | str. | | | 2'-0 | 5 |
| F 405 | 4 | 60 | str. | | | 39'-7 | 1,586 |
| F 406 | 4 | 100 | K | 1'-0 | 1'-3 | 2'-3 | 150 |
| F 601 | 6 | 74 | str. | | | 13'-11 | 1,547 |
| F 602 | 6 | 267 | K | 2'-5 | 4'-0 | 6'-6 | 2,607 |
| F 603 | 6 | 54 | K | 1'-6 | 1'-6 | 8'-0 | 243 |
| F 604 | 6 | 58 | K | 2'-0 | 1'-6 | 3'-6 | 305 |
| F 701 | 7 | 176 | str. | | | 13'-11 | 5,007 |
| V 301 | 3 | 4 | B | 1'-0 | 1'-5 | 3'-10 | 6 |
| V 407 | 4 | 252 | str. | | | 9'-0 | 842 |
| V 408 | 4 | 20 | str. | | | 36'-0 | 481 |
| V 409 | 4 | 20 | str. | | | 39'-2 | 523 |
| V 410 | 4 | 12 | str. | | | 13'-1 | 105 |
| V 411 | 4 | 8 | str. | | | 10'-4 | 55 |
| V 501 | 5 | 28 | str. | | | 5'-0 | 146 |
| V 502 | 5 | 22 | K | 0'-6 | 4'-8 | 5'-2 | 119 |
| V 801 | 8 | 22 | B | 13'-1 | 2'-6 | 18'-1 | 1,062 |
| B 401 | 4 | 22 | H | 0'-11 | | 1'-8 | 24 |
| B 701 | 7 | 4 | str. | | | 12'-0 | 98 |
| B 301 | 3 | 6 | str. | | | 8'-1 | 16 |
| B 302 | 3 | 7 | B | 5'-10 | 1'-6 | 8'-10 | 23 |
| S 601 | 6 | 20 | str. | | | 6'-0 | 180 |
| S 602 | 6 | 6 | G | | | 9'-2 | 83 |
| T 402 | 4 | 8 | K | 1'-3 | 1'-3 | 2'-6 | 13 |
| V 302 | 3 | 7 | D | 1'-8 | 1'-8 | 7'-0 | 18 |
| V 412 | 4 | 8 | str. | | | 7'-8 | 41 |
| P 314 | 3 | 2 | E | 4'-0 | | 4'-10 | 4 |
| P 315 | 3 | 2 | E | 3'-0 | | 3'-10 | 3 |
| V 303 | 3 | 10 | L | | | 2'-3 | 8 |
| V 413 | 4 | 8 | str. | | | 5'-8 | 30 |
| Total Lbs. : 15,603 | | | | | | | |

| BAR LIST: Scale Deck | | | | | | | |
|----------------------|------|-----|------|-------|---|--------|--------|
| Mark | Size | No. | Type | X | Y | Length | Weight |
| D 601 | 6 | 156 | E | 11'-6 | | 12'-10 | 3007 |
| D 404 | 4 | 24 | str. | | | 22'-3 | 365 |
| D 405 | 4 | 24 | str. | | | 14'-6 | 232 |
| D 603 | 6 | 44 | S | 5'-0 | | 5'-8 | 375 |
| D 602 | 6 | 180 | str. | | | 11'-6 | 3,109 |
| D 501 | 5 | 30 | str. | | | 22'-11 | 717 |
| D 502 | 5 | 30 | str. | | | 14'-6 | 454 |
| D 503 | 5 | 15 | str. | | | 5'-0 | 100 |
| Total Lbs. : 8359 | | | | | | | |

| BAR LIST: Sewage and Drainage Systems | | | | | | | |
|---------------------------------------|------|-----|------|------|---|--------|--------|
| Mark | Size | No. | Type | X | Y | Length | Weight |
| D 401 | 4 | 16 | E | 9'-0 | | 10'-0 | 107 |
| D 402 | 4 | 23 | E | 6'-4 | | 7'-4 | 113 |
| D 403 | 4 | 4 | N | | | 2'-2 | 6 |
| E 301 | 3 | 4 | str. | | | 14'-8 | 22 |
| E 302 | 3 | 13 | str. | | | 3'-8 | 18 |
| F 407 | 4 | 4 | str. | | | 9'-6 | 25 |
| F 408 | 4 | 6 | str. | | | 6'-10 | 27 |
| Total Lbs. : 318 | | | | | | | |

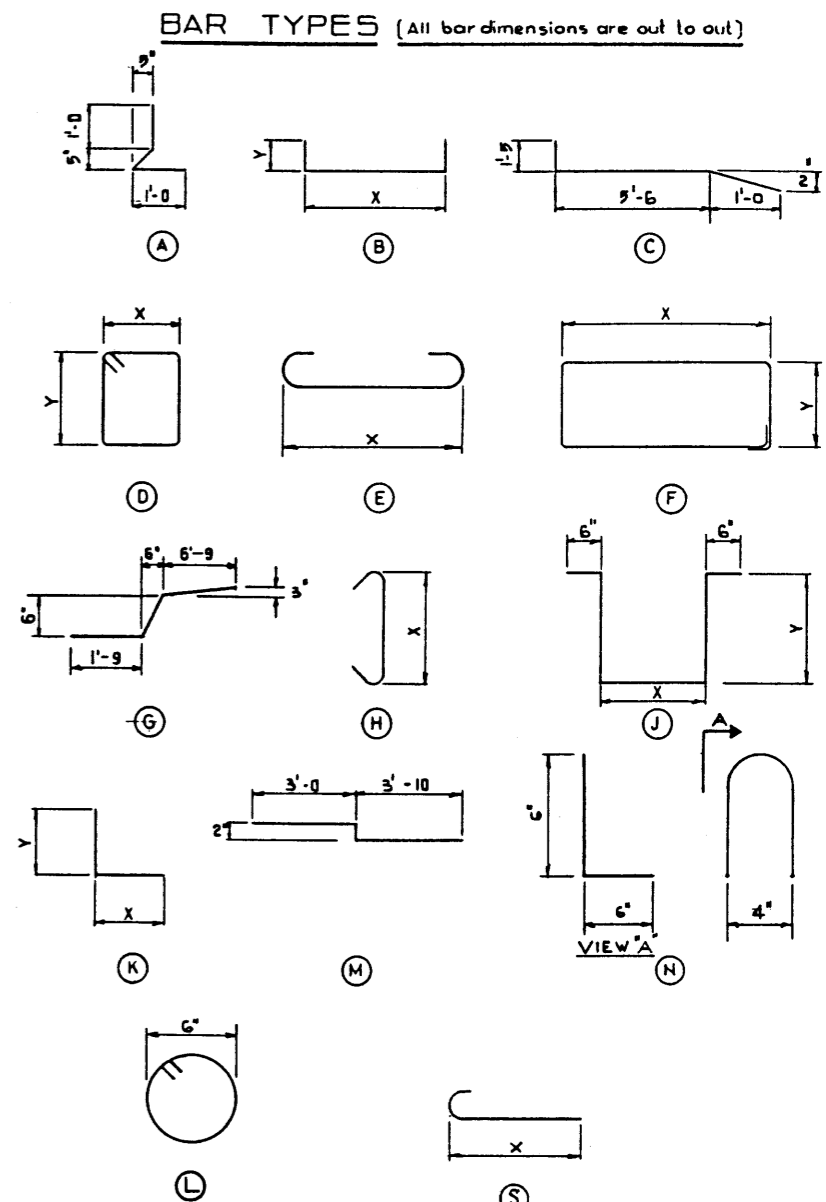

NOTES :

- Diameters of all bends and details of all hooks, unless otherwise noted, shall conform to the recommended sizes detailed in the A.C.I. Manual of Standard Practice for Detailing Reinforced Concrete Structures.
- All reinforcing steel shall be intermediate grade unless otherwise noted.

| | | | |
|--------------------------------|----------------------|--|------------|
| APPROVED | | PROVINCE OF ALBERTA DEPARTMENT OF HIGHWAYS AND TRANSPORT BRIDGE BRANCH | |
| _____ CHIEF BRIDGE ENGINEER | | WEIGH SCALE STATION | |
| REVISIONS | | BAR LISTS | |
| DESIGNED | DRAWN BY | DATE | CHECKED BY |
| | T. S. Miller | Aug. 71 | J. Channoo |
| DATE | DESCRIPTION | BY | DATE |
| | Revised and redrawn. | J.R.C. | Aug. 71 |
| STREAM | LOCATION | HWY. NO. | SCALE |
| | | | N.T.S. |
| FILE NO. | SHEET | DATE | DWG. NO. |
| 3235 | 15 of 15 | | S-1049-72 |

AT 4 - RECORDS CENTRE
720112