

BAR LIST - 45' FC. GIRDER

MARK	SIZE	NO	TYPE	X'	Y'	LENGTH	WEIGHT
H401	4	7	SFR			9'-9"	46
S401	4	11	A	0'-10"	2'-6"	6'-9"	60
S501	5	2	B		4'-2"	6'-4"	13
H501	5	2	STR			9'-9"	20
H701	7	1	STR			9'-9"	20
S402	4	11	C			3'-11"	29
							TOTAL LBS.: 178

BAR LIST - 41' FC. GIRDER

MARK	SIZE	NO	TYPE	X'	Y'	LENGTH	WEIGHT
H401	4	7	STR			9'-9"	46
S401	4	11	A	0'-8 1/2"	2'-2"	6'-4"	47
S501	5	2	B		3'-10"	6'-0"	13
H501	5	2	STR			9'-9"	20
H701	7	1	STR			9'-9"	20
S402	4	11	C			3'-11"	29
							TOTAL LBS.: 175

BAR LIST - 50' FC. GIRDER

MARK	SIZE	NO	TYPE	X'	Y'	LENGTH	WEIGHT
H401	4	7	STR			9'-9"	46
S401	4	11	A	0'-11 1/2"	2'-11"	7'-2"	53
S501	5	2	B		4'-7"	6'-9"	14
H501	5	2	STR			9'-9"	20
H701	7	1	STR			9'-9"	20
S402	4	11	C			3'-11"	29
							TOTAL LBS.: 182

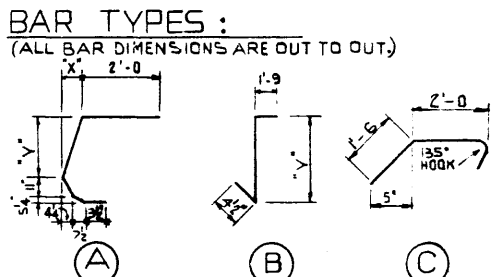

GENERAL NOTES:

DESIGN

A.A.S.H.O. 1963 SPECIFICATION, PLUS 1971 INTERIMS.

MATERIAL

- LIGHT WEIGHT AGGREGATES SHALL CONFORM TO THE REQUIREMENTS OF A.S.T.M. SPECIFICATION C330 WITH MAX. AGGREGATE SIZE OF 3/4". MIN. 28 DAY COMPRESSIVE STRENGTH TO BE 3500 P.S.I. UNIT WEIGH OF THE CONCRETE SHALL BE 105 LBS. PER CUBIC FOOT PLUS OR MINUS 5% IN THE PLASTIC STATE. ENTRAINED AIR SHALL BE NOT LESS THAN 5%.

FABRICATION

- REINFORCEMENT: DIAMETERS OF ALL BENDS SHALL CONFORM TO THE RECOMMENDED SIZES AND ALL HOOKS, UNLESS OTHERWISE NOTED, SHALL CONFORM TO THE RECOMMENDED SIZES DETAILED IN THE A.C.I. MANUAL OF STANDARD PRACTICE FOR DETAILING REINFORCED CONCRETE STRUCTURES.

- GALVANIZING SHALL BE IN ACCORDANCE WITH A.S.T.M. SPEC. A153
- UNITS ARE TO CONFORM TO THE REQUIREMENTS OF THE ALBERTA BRIDGE BRANCH SPECIFICATION B190-G4 FOR THE MANUFACTURE OF PRESTRESSED CONCRETE BRIDGE UNITS.

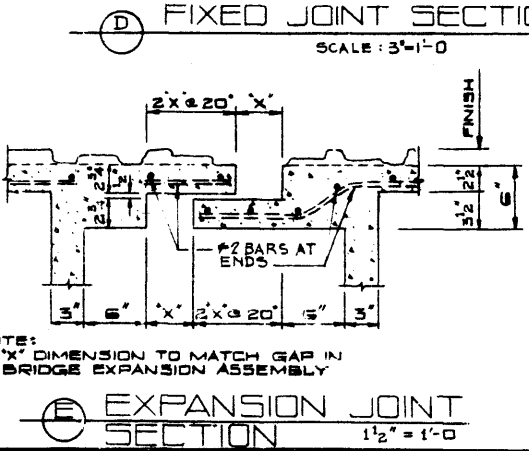
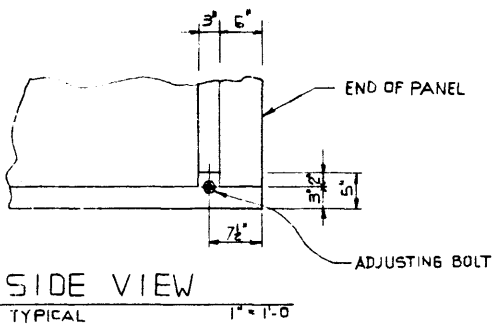
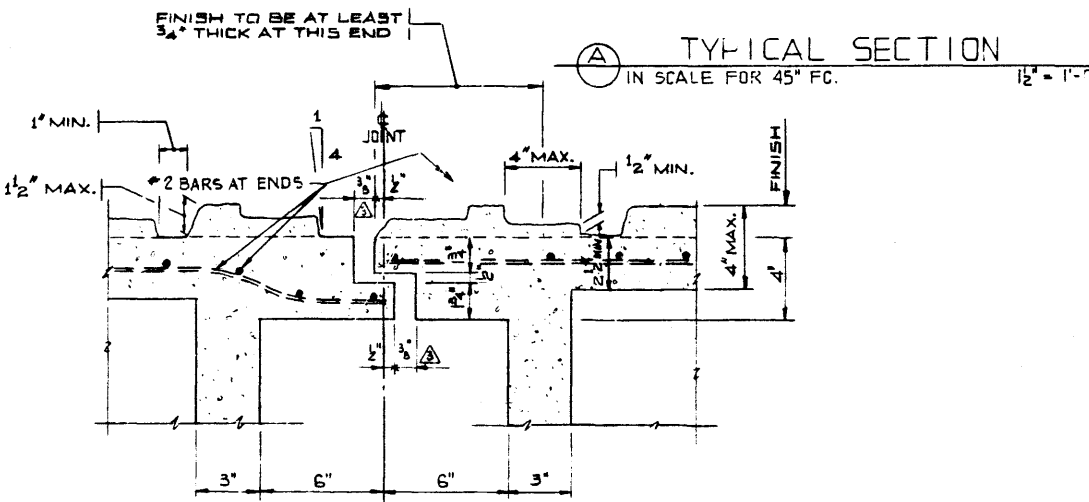
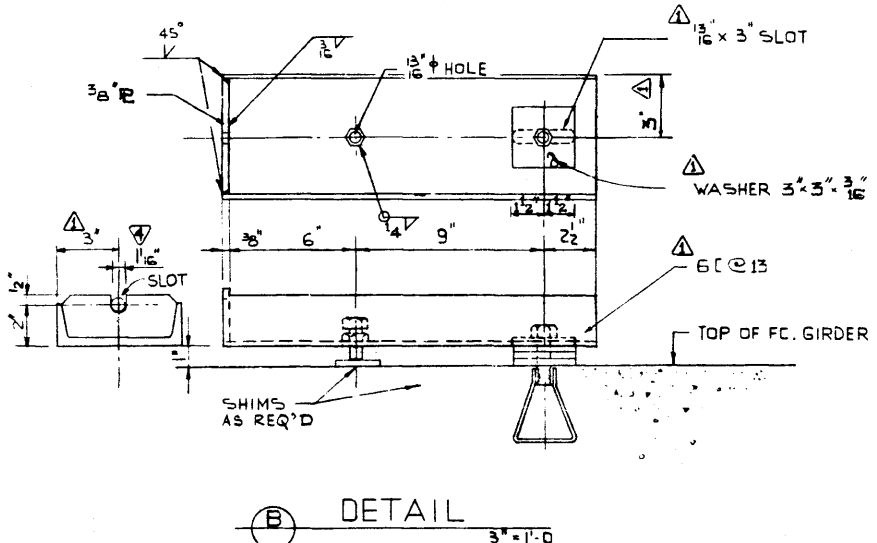

NOTE: X' DIMENSION TO MATCH GAP IN BRIDGE EXPANSION ASSEMBLY

NO.	DATE	DESCRIPTION	BY
30/77		CHANGED DIMENSION - HANGER	R.W.L.
02/77		CHANGED DIMENSION - FIXED JOINT	T.B.
NOV 72		BAR WT.	T.B.
NOV 72		HANGER SIZE	T.B.

APPROVED

CHIEF BRIDGE ENGINEER

DATE

PROVINCE OF ALBERTA
DEPARTMENT OF HIGHWAYS AND TRANSPORT
BRIDGE BRANCH

FC GIRDER FASCIA

DESIGNED	DRAWN BY	DATE	CHECKED BY	DATE	STREAM	LOCATION	HWY. NO.	SCALE	FILE NO.	SHEET	DWG. NO.
T. BELKE	L. KOHLMANN	JUNE 1972	R.L. FOSTER	OCT. 1972				SHOWN		OF	5-1071