

BAR LIST: FOR UNSKEWED GIRDER

MARK	SIZE	NO.	TYPE	X	Y	LENGTH	WEIGHT
C 401	4	3	STR.			54'-8	110
C 501	5	44	A			5'-6	252
C 502	5	44	B			2'-10	130
S 301	3	86	C			3'-9	121
S 404	4	59	D			7'-3	286
S 401	4	59	E	2'-5 1/2	8'-2	3'-11	154
S 402	4	1	STR.			54'-8	37
S 403	4	11	F			2'-0	15
E 401	4	4	G			3'-2	8
E 402	4	2	E	2'-5 1/2	6'	3'-7	5
E 403	4	2	H			9'-0	12
E 501	5	4	J			6'-11	29
S 405	4	10	STR.			5'-0	33
C 402	4		E	7 1/2"	1'-6	3'-7 1/2	
C 403	4		E	1'-1 1/2	1'-6	4'-1 1/2	

TOTAL LBS: 1192

GENERAL NOTES

DESIGN:

AASHO 1969 SPECIFICATION.

LOADING: 0.60 OF ONE WHEEL LINE OF AN HS25-44 TRUCK PLUS FULL DEAD LOAD PLUS 2 INCH WEARING SURFACE.

CALCULATED WEIGHT OF ONE GIRDER = 44.2 KIPS.

MATERIALS:

CURB CONCRETE SHALL BE OF STANDARD WEIGHT AGGREGATE WITH A MAXIMUM AGGREGATE SIZE OF 3/4". MINIMUM COMPRESSIVE STRENGTH SHALL BE 5000 PSI AT 28 DAYS. ENTRAINED AIR SHALL BE NOT LESS THAN 3%.

STRINGER CONCRETE SHALL BE MANUFACTURED USING LIGHTWEIGHT COARSE AGGREGATE AND SAND FINES. LIGHTWEIGHT AGGREGATE SHALL CONFORM TO THE REQUIREMENTS OF A. S. T. M. SPECIFICATION C 330 WITH MAXIMUM AGGREGATE SIZE OF 3/4 INCH. MINIMUM COMPRESSIVE STRENGTH SHALL BE 5000 PSI AT 28 DAYS. UNIT WEIGHT OF THE CONCRETE SHALL BE 120 LBS. PER CUBIC FOOT PLUS OR MINUS 3% IN THE PLASTIC STATE. ENTRAINED AIR SHALL BE NOT LESS THAN 3%.

PRESTRESSING STEEL SHALL BE 7/16 INCH DIAMETER - 7 WIRE - 270 K STRAND.

FABRICATION:

GIRDERS SHALL CONFORM TO THE REQUIREMENTS OF THE ALBERTA BRIDGE BRANCH SPECIFICATION B 190-64 FOR THE MANUFACTURE OF PRESTRESSED CONCRETE BRIDGE UNITS.

REINFORCEMENT: DIAMETERS OF ALL BENDS SHALL CONFORM TO THE RECOMMENDED MINIMUMS AND ALL HOOKS, UNLESS OTHERWISE NOTED, SHALL CONFORM TO THE RECOMMENDED SIZES DETAILED IN THE A. C. I. MANUAL OF STANDARD PRACTICE FOR DETAILING REINFORCED CONCRETE STRUCTURES.

PRESTRESSING STEEL: INITIAL TENSIONING LOAD = 28.91 K/STRAND. DESIGN LOAD = 22.34 K/STRAND.

CONCRETE MUST ATTAIN 4000 PSI COMPRESSIVE STRENGTH BEFORE THE PRESTRESSING FORCE IS TRANSFERRED.

THE SURFACE OF GROUT KEYS AND END BLOCKOUTS SHALL BE SANDBLASTED, TO EXPOSE THE COARSE AGGREGATE.

ANCHOR BOLT ASSEMBLIES SHALL BE CAST IN GIRDER AT SPACINGS AS REQUIRED.

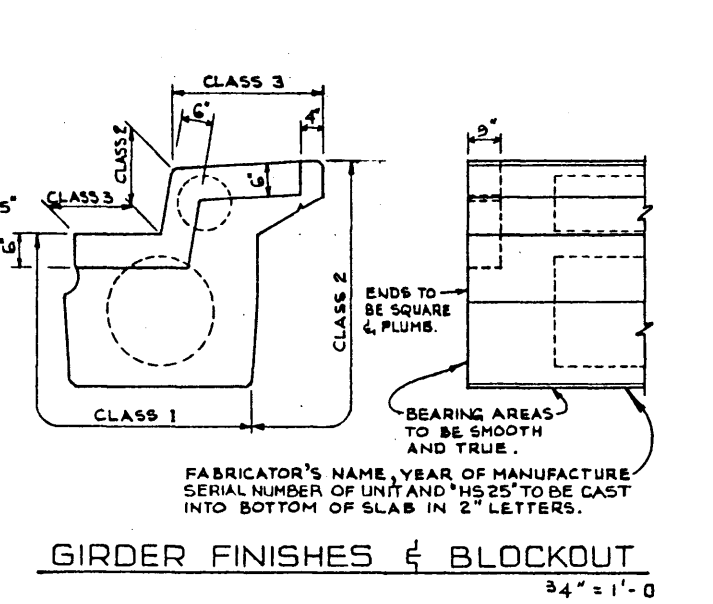
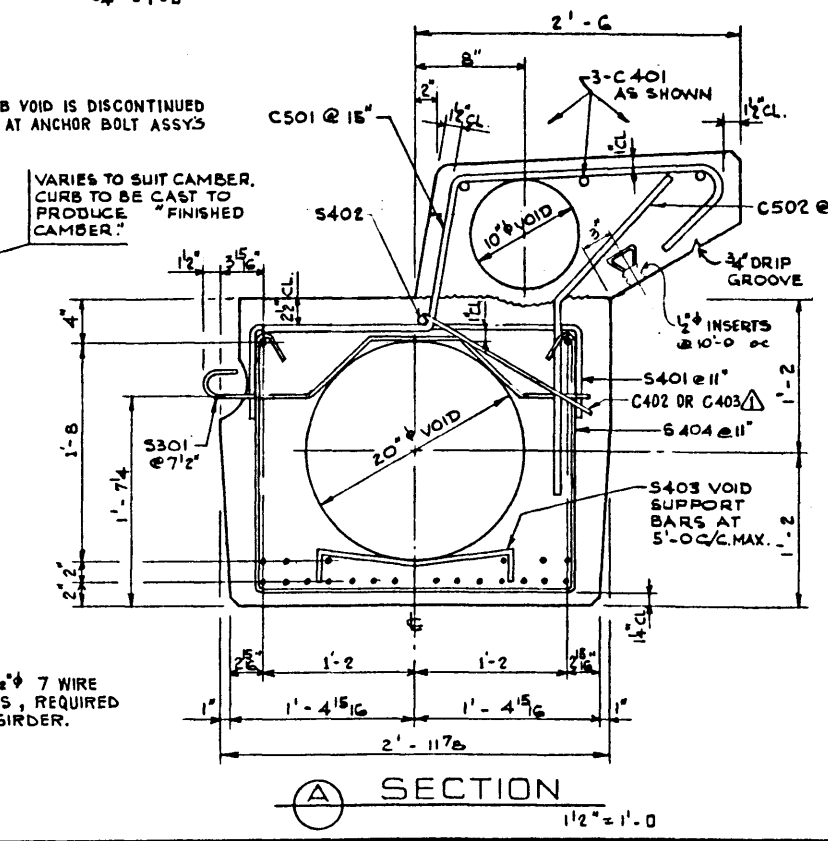
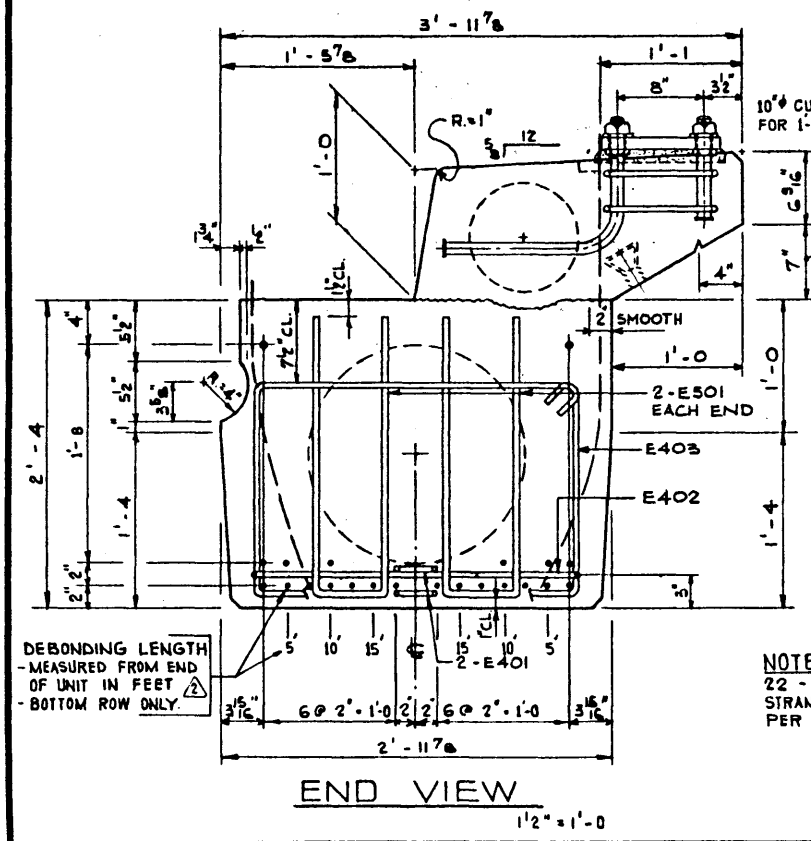
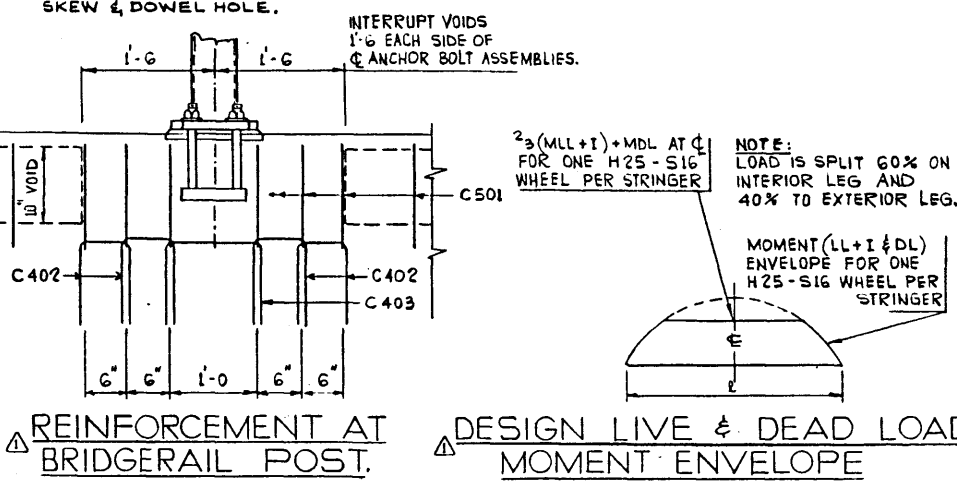

APPROVED		PROVINCE OF ALBERTA DEPARTMENT OF HIGHWAYS AND TRANSPORT BRIDGE BRANCH	
DEC 5/73 DEBONDING LENGTH		55'-0 TYPE "VM" 28" CURB GIRDER HS 25 LOADING	
DEC 3/73 BRIDGERAIL POST REINFORCEMENT		R.W. LYNE	
NO.	DATE	DESCRIPTION	BY
REVISIONS			
DESIGNED	DRAWN BY	DATE	CHECKED BY
R.W. LYNE	Y.B. & F.B.	NOV. 73	
DATE	STREAM	LOCATION	HWY. NO.
			SCALE
			FILE NO.
			SHEET
			DWG NO.
			S-1105