

JOINT TYPE 1

EDGES SHALL BE TROWELLED WITH A SIDEWALK TOOL

TOOL MARKS SHALL BE FLOATED OFF

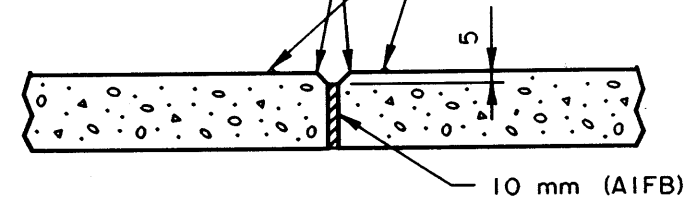

JOINT TYPE 2

TOP SURFACES SHALL BE FLUSH

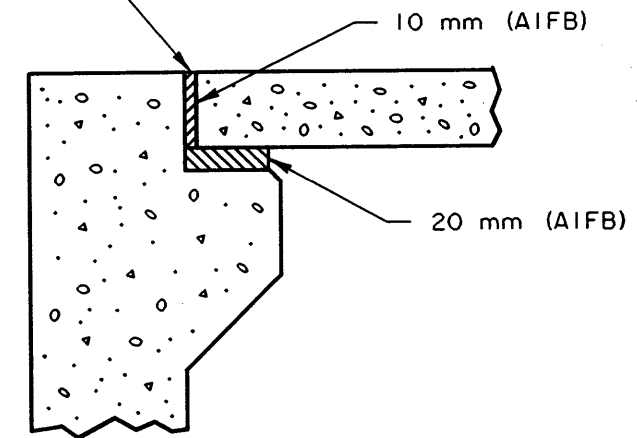

JOINT TYPE 3

GENERAL NOTES

- DIMENSIONS ARE GIVEN IN mm. DETAILS ARE NOT TO SCALE.
- ASPHALT IMPREGNATED FIBREBOARD (AIFB) SHALL CONFORM TO THE CURRENT ASTM SPECIFICATION D1751 FOR PREFORMED EXPANSION JOINT FILLERS.

SUPERSEDED
 BY S-1411-87 REV 3 & 4
 99-04-14 ON SHEET 5

④

DRAFTING STANDARDS PAGE: 6.2

				Alberta TRANSPORTATION AND UTILITIES BRIDGE ENGINEERING BRANCH	
				STANDARD CONCRETE JOINTS	
DESIGNED	DRAWN	DATE	APPROVED	SIGNATURE	DATE
DHQ	MIK	87-03-04	EXECUTIVE DIRECTOR	<i>[Signature]</i>	11/4/87
NO	DATE	REVISIONS	BY		
④	94-11-30	PAGE NUMBER	RJR		
③	87-03-04	REDRAWN FROM S-1411	DHQ		
				PAGE	DRAWING
				4.33	S-1411-87