

NOTE:
BEND REINFORCING BAR WHERE NECESSARY TO ACCOMMODATE CHANNEL CONNECTORS. STIRRUP SPACING TO BE MAINTAINED.

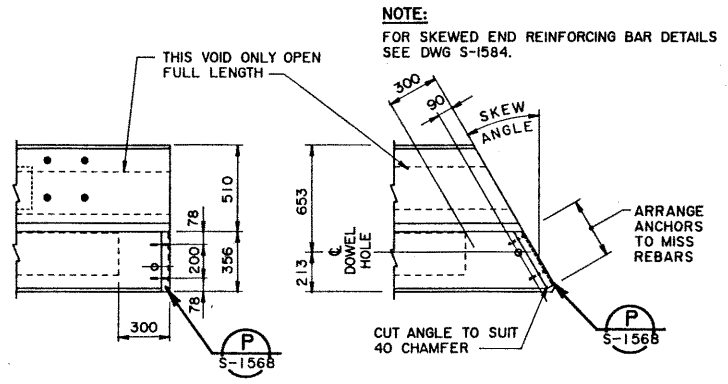

NOTE:
FOR SKEWED END REINFORCING BAR DETAILS SEE DWG S-1584.

BAR LIST: FOR SQUARE GIRDER							
MARK	SIZE	NO	TYPE	X	Y	LENGTH	MASS
C1003	10	3	STR			9 960	23
C1008	10	2	A	310	600	1 510	2
C1501	15	50	E			1 455	114
G1006	10	6	D			1 080	5
G1010	10	2	STR			9 960	16
G1011	10	2	STR			9 860	15
G1026	10	45	A	725	300	1 325	47
G1027	10	57	B	725		1 820	81
G1028	10	2	A	600	300	1 200	2
G1029	10	6	STR			700	3
G1501	15	57	C			1 140	102
G2501	25	2	A	9 910	350	10 610	83

TOTAL kg : 493

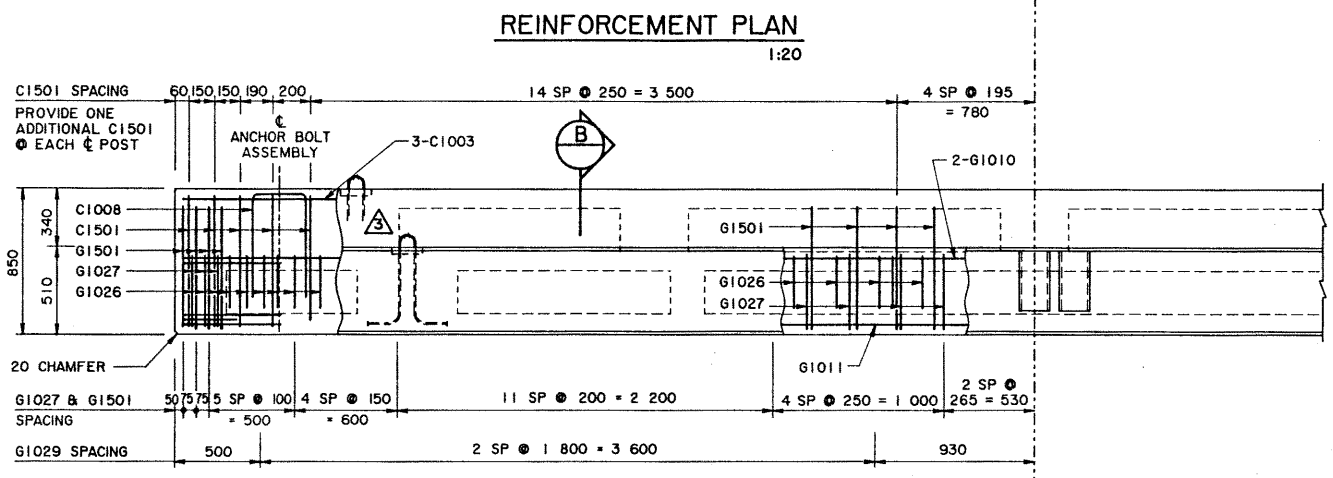
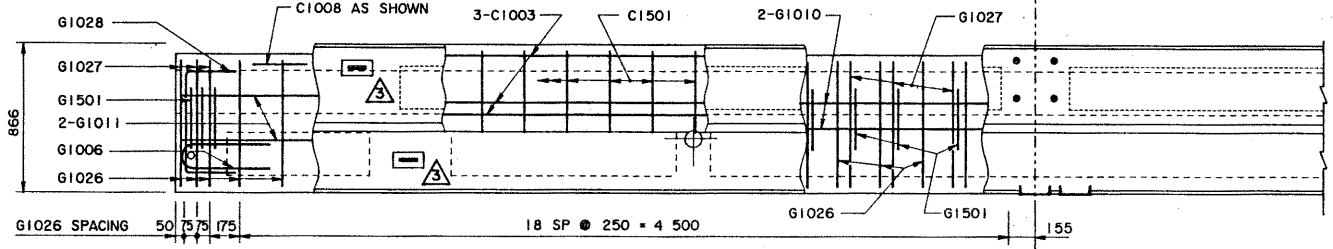

ELEVATION 1:20

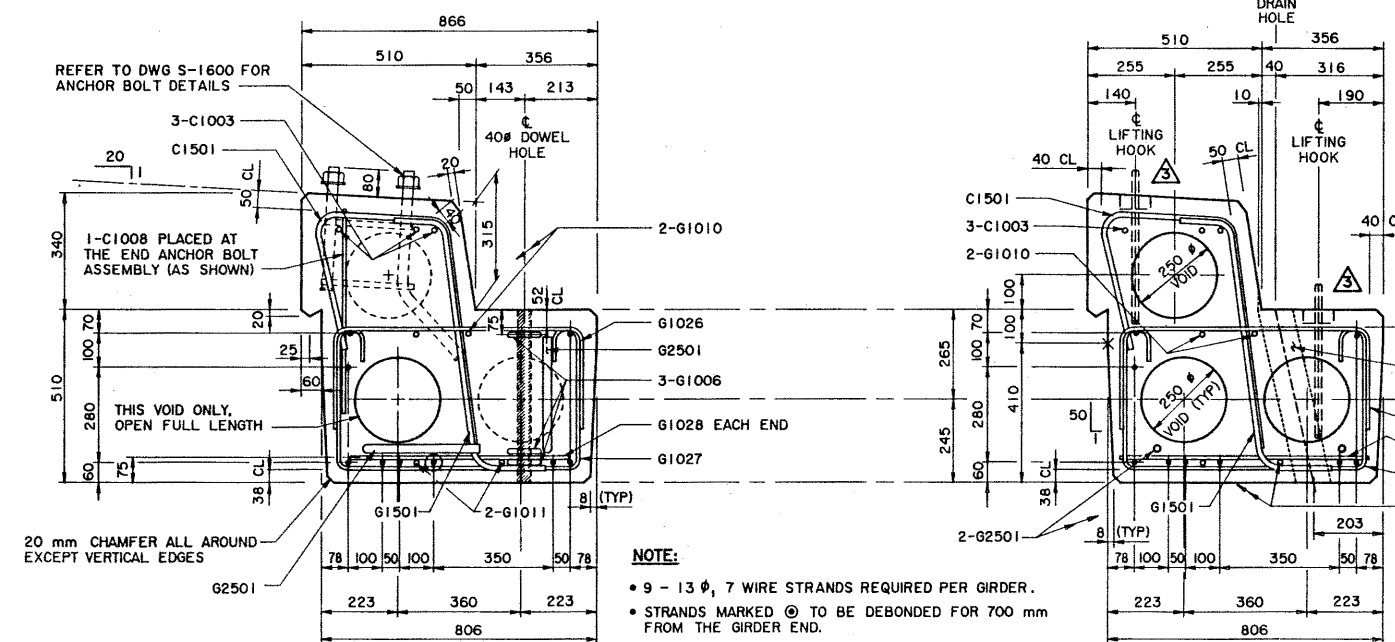

NOTE:
• 9 - 13 φ, 7 WIRE STRANDS REQUIRED PER GIRDER.
• STRANDS MARKED © TO BE DEBONDED FOR 700 mm FROM THE GIRDER END.

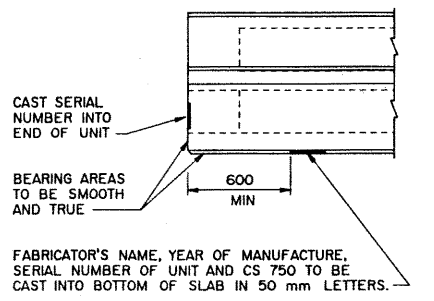
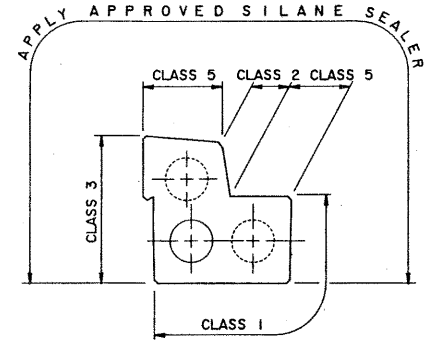

GIRDER FINISHES (BY FABRICATOR) 1:20

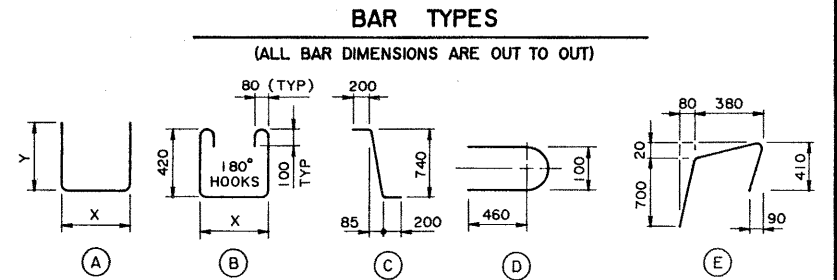

GENERAL NOTES

- ALL DRAWING REFERENCES ARE TO CURRENT DRAWINGS.
- DESIGN**
 - CAN/CSA-S6-88 SPECIFICATIONS EXCEPT AS MODIFIED BELOW:
 - ALLOWABLE TENSION AT MIDSPAN IS 40% OF MODULUS OF RUPTURE (SEVERE EXPOSURE CONDITIONS).
 - NO TENSION ALLOWED IN DECK SURFACE.
- LOADING:**
 - LIVE LOAD - CAN/CSA-S6-88; CS-750
 - 0.8 WHEEL LINES PER GIRDER
 - DEAD LOAD - GIRDER = 0.86 t/m
 - WEARING SURFACE = 0.09 t/m
- MATERIALS**
 - CONCRETE SHALL CONTAIN SILICA FUME AND BE MADE OF LIGHTWEIGHT COARSE AGGREGATE AND NATURAL SAND FINES. UNIT WEIGHT OF SEMI-LIGHTWEIGHT CONCRETE SHALL BE 1920 kg/m³.
 - 28 DAY CONCRETE STRENGTH - 35 MPa
 - RELEASE STRENGTH - 28 MPa
 - PRESTRESSING STEEL SHALL BE 13 φ, 7 WIRE LOW RELAXATION STRAND (f_{pu} = 1860 MPa).
 - REINFORCING STEEL SHALL BE GRADE 400W (YIELD STRENGTH OF GRADE 300 USED IN DESIGN TO ALLOW TACK WELDING OF SHEAR REINFORCEMENT).
- FABRICATION**
 - GIRDS SHALL CONFORM TO THE CURRENT REQUIREMENTS OF THE BRIDGE MATERIALS SPECIFICATION FOR THE MANUFACTURE OF PRESTRESSED CONCRETE BRIDGE UNITS (SPEC B190).
 - FORCE IN PRESTRESSING STEEL:
 - INITIAL TENSIONING LOAD = 129 kN/STRAND
 - DESIGN LOAD AFTER LOSSES = 112 kN/STRAND
 - CURB SHALL BE CAST MONOLITHICALLY WITH GIRDER.
 - ANCHOR BOLT ASSEMBLIES SHALL BE CAST IN GIRDER AT SPACINGS SHOWN ON DRAWING.
 - ALL GALVANIZING SHALL CONFORM TO ASTM SPEC A123 OR A153 AS APPLICABLE.
 - BEND OR SHIFT REINFORCING WHERE REQUIRED TO CLEAR CHANNEL CONNECTOR AND LIFTING HOOK ASSEMBLIES. STIRRUP SPACING SHALL BE MAINTAINED FOR CHANNEL CONNECTOR AND LIFTING HOOK LOCATIONS SEE DWG S-1570.
- ERECTION**
 - ANY FREE SPACE BETWEEN CONNECTORS SHALL BE FILLED WITH DROP-IN WASHERS.
 - CALCULATED MASS OF ONE GIRDER IS 9.1t.

SUPERSEDED
BY REVISION A

SUPERSEDED

APPROVED		Albarta TRANSPORTATION AND UTILITIES BRIDGE ENGINEERING BRANCH	
EXECUTIVE DIRECTOR BRIDGE ENGINEERING		PRESTRESSED CONCRETE 10.06 m TYPE SC-510 CURB GIRDER	
REV	DATE	REVISIONS	BY
94-04-05		LIFTING HOOK POCKET	LEA
93-12-13		BAR LENGTH REVISED	SBD
93-08-27		CONNECTOR & LIFTING HOOK LOCATION NOTE	LEA
DESIGNED	DRAWN	DATE	CHECKED
LEA	VMV	93-08-23	SBD
DATE	DATE	STREAM	LOCATION
94-05-16			
SHEET	FILE	DATE	DRAWING
2 of 4		May 24/94	S-1569

