

DATA FOR STANDARD SC PRECAST GIRDER BRIDGES

CLEAR ROADWAY (GIRDERS / SPAN)	8 000 ( 8 )				9 200 ( 9 )				10 400 (10)				11 600 (11)				12 800 (12)				14 000 (13)				
	0°	15°	30°	45°	0°	15°	30°	45°	0°	15°	30°	45°	0°	15°	30°	45°	0°	15°	30°	45°	0°	15°	30°	45°	
OVERALL LENGTH	9 100	9 420	10 508	12 870	10 300	10 664	11 894	14 566	11 500	11 906	13 278	16 266	12 800	13 248	14 780	18 104	14 000	14 494	16 168	19 802	15 200	15 734	17 552	21 498	
CROWN	91	91	91	91	103	103	103	103	115	115	115	115	128	128	128	128	140	140	140	140	152	152	152	152	
DIFFERENTIAL FOR ROADWAY GRADE OF	1% C	0	24	53	91	0	28	59	103	0	31	66	115	0	34	74	128	0	38	81	140	0	41	88	152
	2% C	0	49	105	182	0	55	119	206	0	62	133	230	0	69	148	256	0	75	162	280	0	81	176	304
	3% C	0	73	158	273	0	83	178	309	0	92	199	345	0	103	222	384	0	113	242	420	0	122	263	456
NUMBER	6	6	6	6	6	6	6	6	7	7	7	7	8	8	8	8	9	9	9	9	9	9	9	9	
SPACING	1 400	1 449	1 617	1 980	1 640	1 698	1 894	2 319	1 567	1 622	1 809	2 216	1 529	1 582	1 765	2 162	1 488	1 540	1 718	2 104	1 638	1 695	1 891	2 316	
END DISTANCES	1 050	1 087	1 212	1 485	1 050	1 087	1 212	1 485	1 050	1 087	1 212	1 485	1 050	1 087	1 212	1 485	1 050	1 087	1 212	1 485	1 050	1 087	1 212	1 485	
NUMBER OF DOWELS PER LINE	8	8	8	8	9	9	9	9	10	10	10	10	11	11	11	11	12	12	12	12	13	13	13	13	
CURB GIRDER LOCATION FROM BRIDGE	4 450	4 607	5 138	6 293	5 050	5 228	5 831	7 142	5 650	5 849	6 524	7 990	6 250	6 470	7 217	8 839	6 850	7 092	7 910	9 687	7 450	7 713	8 603	10 536	
NOMINAL GAP BETWEEN GIRDERS	7	8	9	10	6	6	7	8	4	5	5	6	3	4	4	5	3	3	3	4	2	2	2	3	

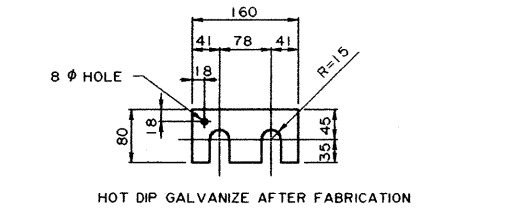

**DROP-IN WASHER**  
S-1603-94 1:5  
FOR SC-510 GIRDER TO GIRDER CONNECTIONS  
IN 2 mm AND 4 mm THICKNESSES

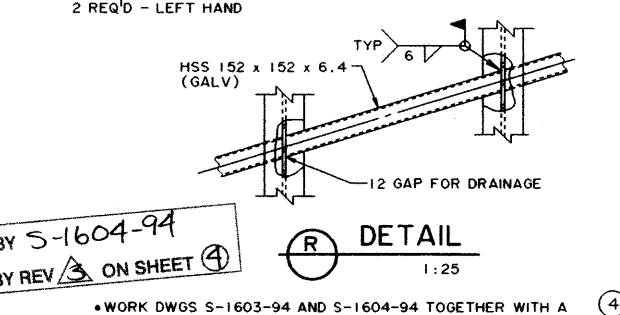
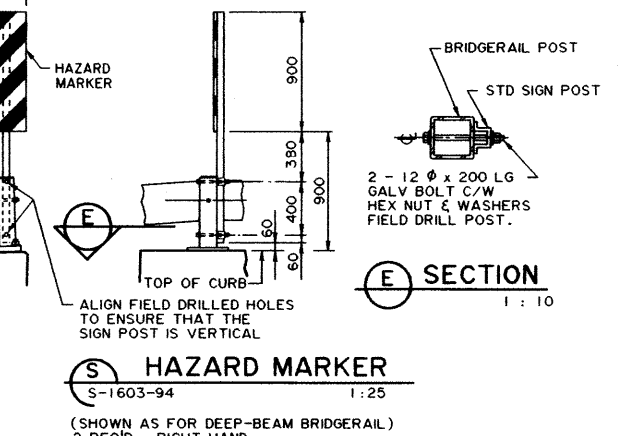
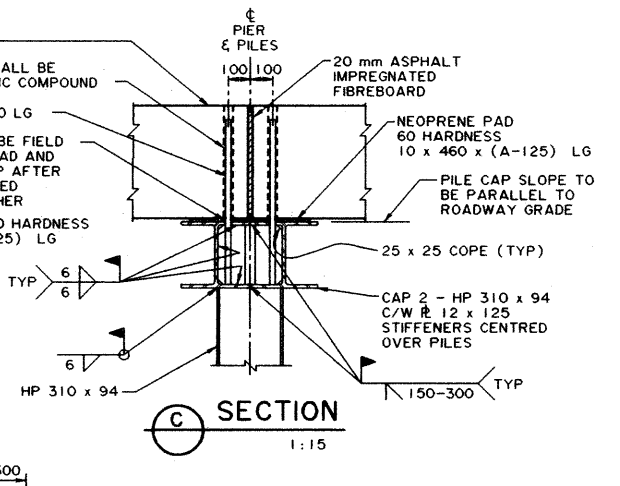
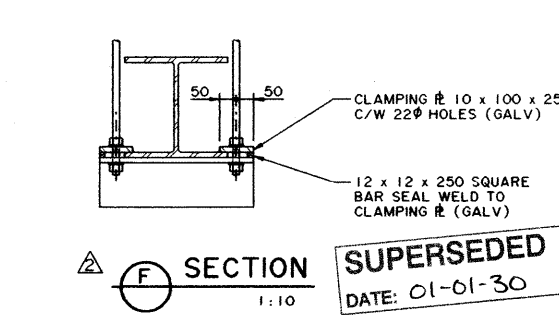
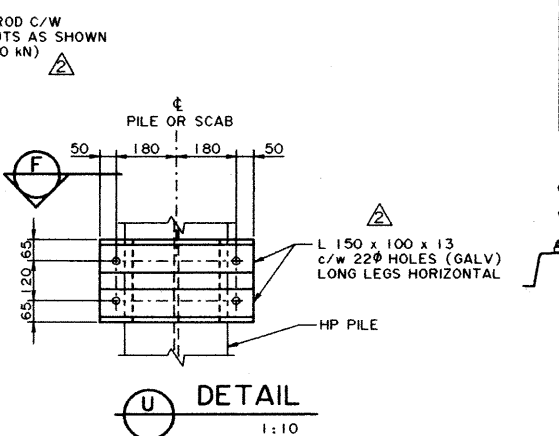
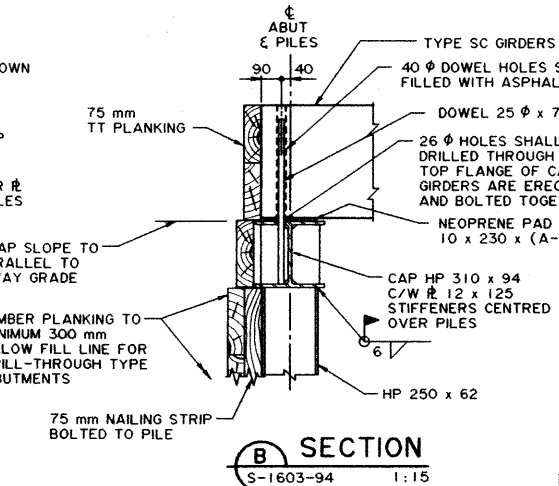
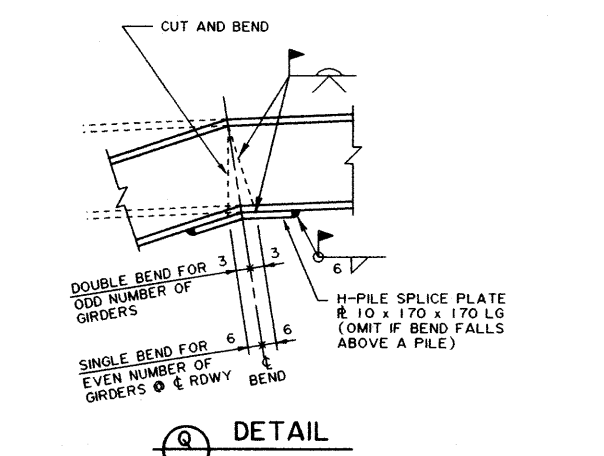
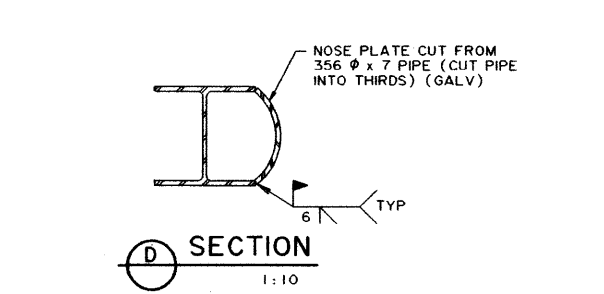
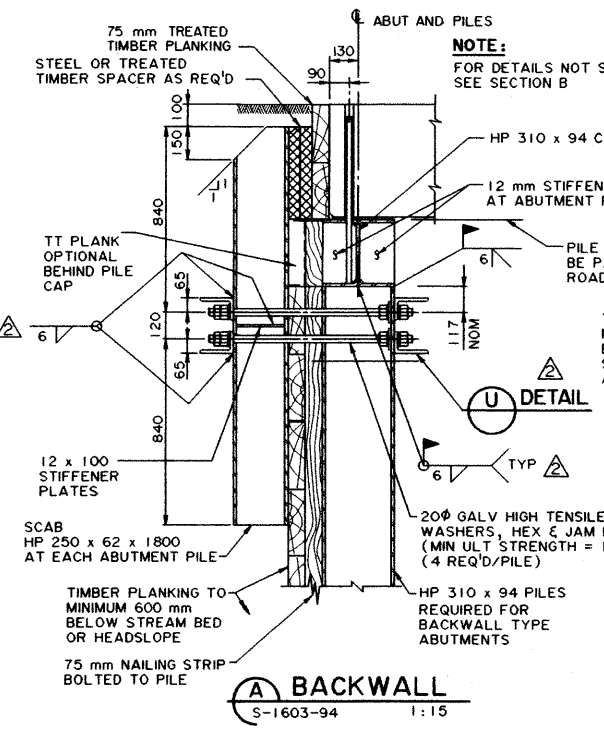
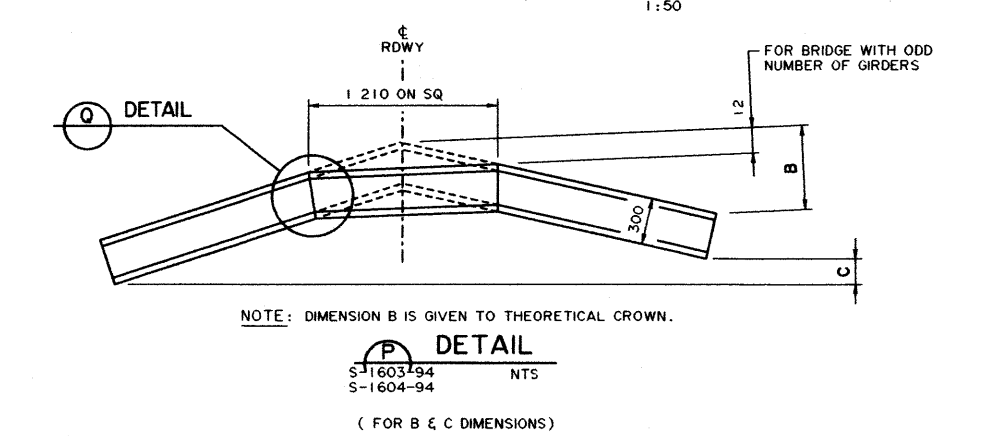
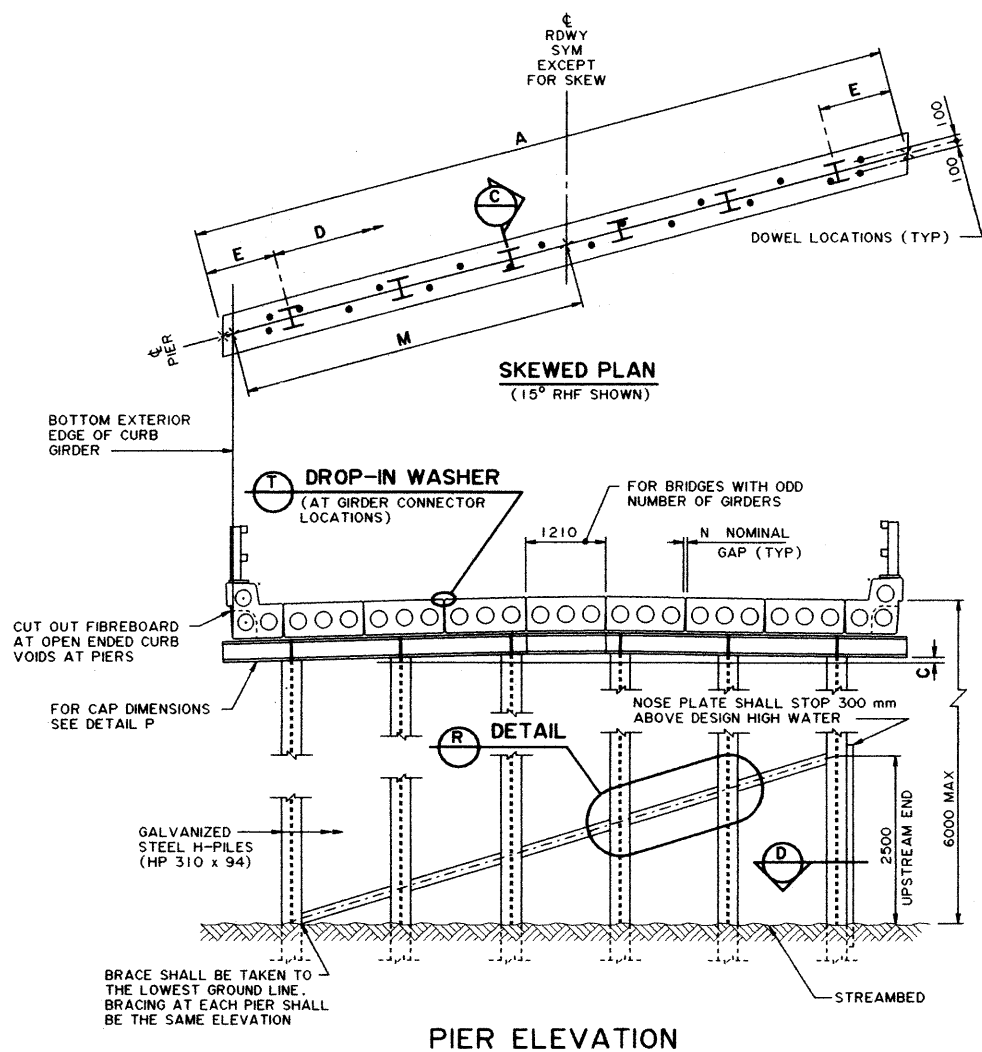

**SUPERSEDED BY S-1604-94**  
DATE: 01-01-30 BY REV 3 ON SHEET 4

WORK DWGS S-1603-94 AND S-1604-94 TOGETHER WITH A SITE SPECIFIC GENERAL LAYOUT OR A BRIDGE AUTHORIZATION.

REV	DATE	DESCRIPTION	BY	DATE	STREAM	LOCATION	HIGHWAY	FILE	SHEET	DRAWING
00-12-12		U-DETAIL AND F-SECTION	LEA							
94-03-15		REDRAWN FROM S-1603 & S1604	LEA							

DESIGNED	DRAWN	DATE	CHECKED	DATE	STREAM	LOCATION	HIGHWAY	FILE	SHEET	DRAWING
KST LEA	VGB MK	94-03-15							2 of 2	S-1604-94

NOTE: THIS DRAWING HAS BEEN REDUCED TO 22"x34" DO NOT SCALE