

**GENERAL NOTES**

- ALL DIMENSIONS ARE IN MILLIMETRES UNLESS NOTED OTHERWISE.
- SNOW PLOW GUARDS ARE REQUIRED FOR BRIDGE SKEW ANGLES RANGING FROM 20° TO 45° INCLUSIVE.
- SNOW PLOW GUARDS ARE NORMALLY REQUIRED FOR LHF SKEWS ONLY. HOWEVER, FOR DIVIDED HIGHWAYS WHERE IT IS LIKELY FOR SNOW REMOVAL VEHICLES TO THROW SNOW TOWARD THE MEDIAN, SNOW PLOW GUARDS ARE REQUIRED FOR BOTH RHF AND LHF SKEWS.
- REFER TO SITE SPECIFIC DRAWINGS FOR DIMENSIONS "A" THROUGH "K", "W" AND "X" AND SITE SPECIFIC DETAILS NOT SHOWN ON THIS DRAWING.
- MAXIMUM GAP "X" SHALL NOT EXCEED 115 mm. FOR FIXED JOINTS "X" = 70 mm.
- ALL STEEL SHALL CONFORM TO THE REQUIREMENTS OF CAN3- 640.21M-300W OR ASTM A36.

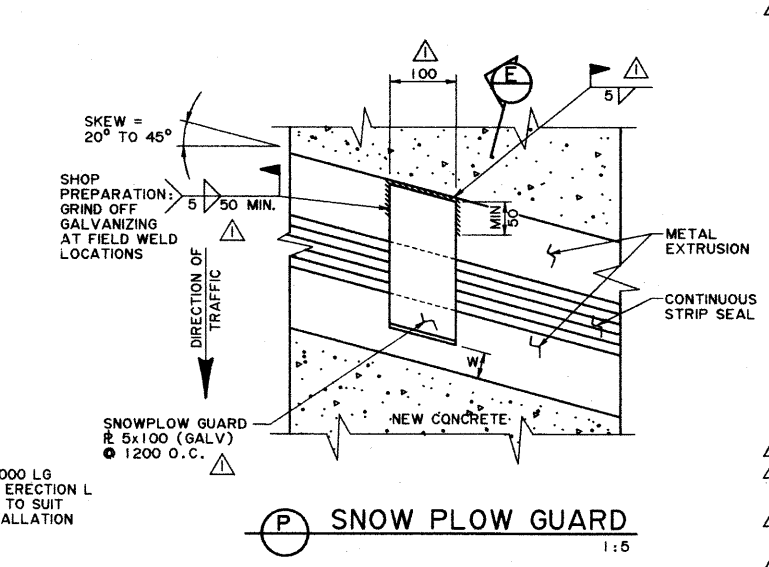
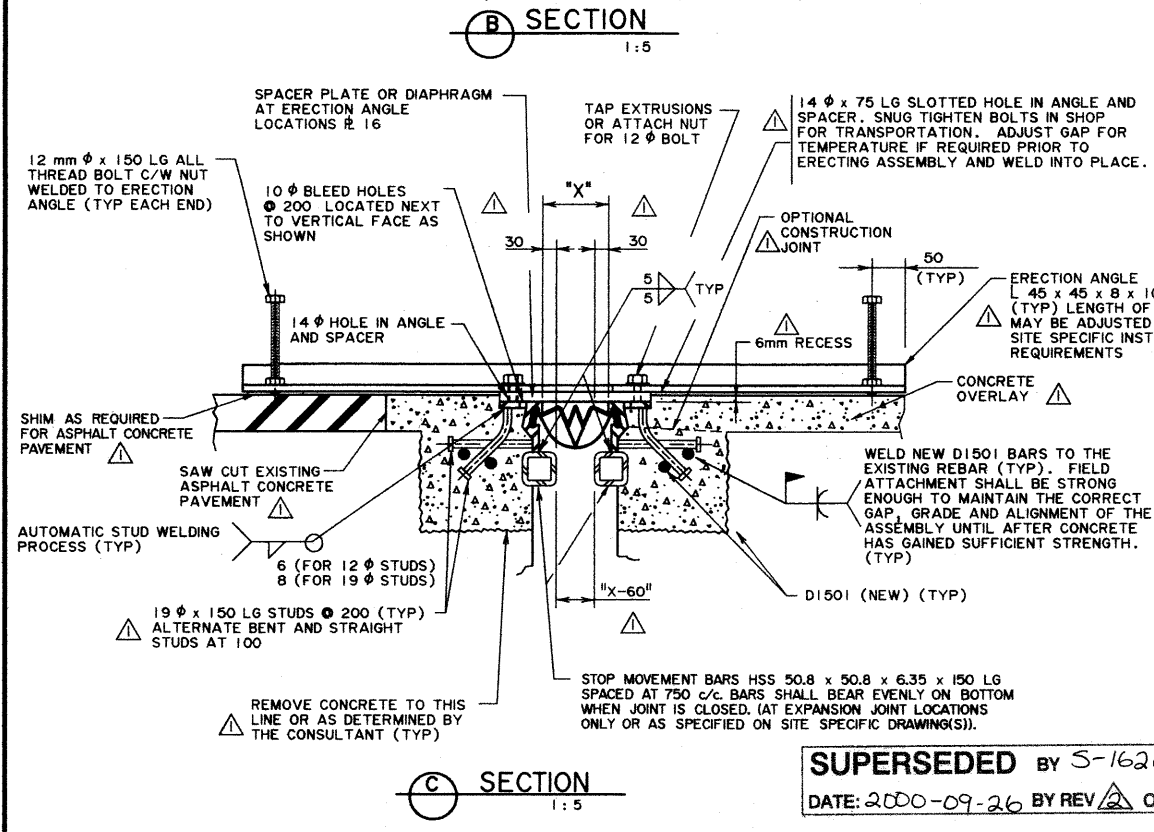

**MATERIALS AND FABRICATION**

- CONTINUOUS SEALING SYSTEM TO BE ONE OF THE FOLLOWING TYPES:
  - ELASTOMETAL "EFE400" WITH TYPE "M" EXTRUSION
  - HONEL GSH 141 "W-DE" SYSTEM (SHOWN)
  - DS BROWN "0400" SEAL WITH TYPE SSCM EXTRUSION
  - MULTI-WEB STRIP SEAL SHALL BE NEOPRENE, NATURAL RUBBER OR APPROVED EQUIVALENT.
  - ALL REQUIREMENTS OF THE CURRENT SPECIFICATIONS FOR BRIDGE CONSTRUCTION (SECTION 6) SHALL BE MET.
  - METAL EXTRUSIONS SHALL BE SUPPLIED IN TWO PIECES UNLESS NOTED OTHERWISE, STRIP SEAL SHALL BE SUPPLIED IN ONE CONTINUOUS LENGTH.
  - BOLTED CURB COVER PLATES SHALL BE HOT DIP GALVANIZED AFTER FABRICATION. ALL OTHER METAL PARTS EXCEPT ERECTION ANGLES, SPACER PLATES AND STAINLESS STEEL BOLTS SHALL BE HOT DIP GALVANIZED OR ZINC METALLIZED AFTER FABRICATION.
  - ALL GALVANIZING SHALL MEET ASTM SPEC A123 OR A153 AS APPLICABLE.
  - ZINC METALLIZING SHALL BE 180 MICRONS THICK AND IN ACCORDANCE WITH CSA G-189.
  - ALL WELDING SHALL CONFORM TO CURRENT AWS SPECIFICATION D1.5.
  - SHOP ASSEMBLE FOR INSPECTION IN A RELAXED CONDITION WITH ERECTION ANGLES REMOVED. APPROVAL OF ASSEMBLY REQUIRED PRIOR TO APPLICATION OF ERECTION ANGLES.
  - PRESET GAP IN SHOP FOR A TEMPERATURE OF +15°C.
  - JOINT SHALL BE TRANSPORTED WITH ERECTION ANGLES ATTACHED AND THE EXTRUSION CAVITY SEALED WITH TAPE.

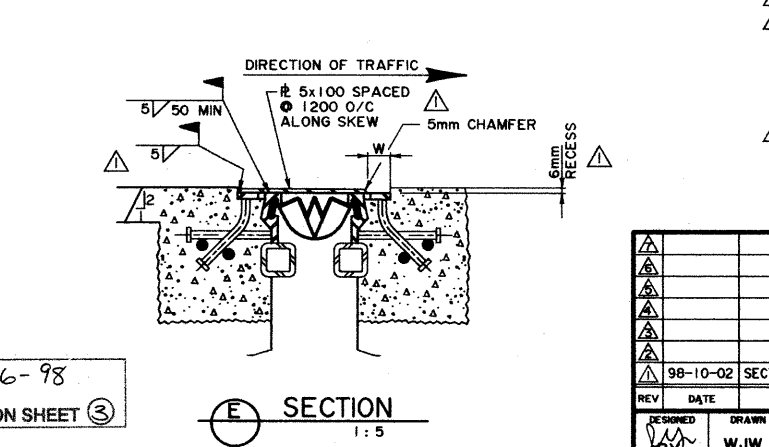

**JOINT INSTALLATION**

- ERECT ASSEMBLY.
- MAINTAIN THE DECK JOINTS' PRESET GAP UNLESS ADVISED TO RESET GAP BY THE CONSULTANT.
- SECURE ROADWAY PORTION OF ASSEMBLY TO GRIDERS/DECK/BACKWALL BY BOLTING/WELDING. THE ATTACHMENT SHALL BE STRONG ENOUGH TO MAINTAIN THE CORRECT GAP, GRADE AND ALIGNMENT OF THE ASSEMBLY UNTIL AFTER CONCRETE PLACEMENT.
- AFTER ASSEMBLY IS SECURELY ATTACHED, LOOSEN BOLTS IN SLOTTED HOLES IN THE ERECTION ANGLES SUFFICIENTLY TO ALLOW TEMPERATURE MOVEMENT WITHOUT DAMAGING BRIDGE COMPONENTS. OBSERVE THAT CLAMPED PARTS DO NOT DEFORM WHEN BOLTS ARE LOOSENED.
- CHECK ASSEMBLY GRADE AND ELEVATION. PROCEED WITH CONCRETE PLACEMENT AFTER APPROVAL BY CONSULTANT.
- REMOVE ERECTION ANGLES AND FINISHING STRIPS AFTER CONCRETE HAS SET.
- REMOVE ALL FORMWORK AND CLEAN EXCESS CONCRETE AND DEBRIS FROM ASSEMBLY.
- INSTALL THE CURB PORTIONS OF THE DECK JOINT ASSEMBLY AND PLACE CONCRETE AS SPECIFIED. REMOVE CURB ASSEMBLY ERECTION ANGLES IMMEDIATELY AFTER CONCRETE IS PLACED.
- APPLY SILANE SEALER TO EXPOSED CONCRETE SURFACES.
- WELD SNOW PLOW GUARD PLATES AFTER SEAL INSTALLATION.
- APPLY TWO COATS OF ZINC RICH PAINT ON AREAS DAMAGED BY FIELD WELDING.
- FIELD WELDED SPICE SHALL BE AS PER SECTION 13 OF THE SPECIFICATIONS FOR BRIDGE CONSTRUCTION.

**SEAL INSTALLATION**

- REMOVE CURB COVER PLATES WHEN JOINT IS READY FOR STRIP SEAL INSTALLATION. SUPPLIER SHALL INSTALL SEAL AND TORQUE CURB COVER PLATE BOLTS TO 1/3 TURN FROM SNUG TIGHT CONDITION.

NOTE: THIS DRAWING HAS BEEN REDUCED TO 22"x34" DO NOT SCALE

**SUPERSEDED BY 5-1626-98**  
DATE: 2000-09-26 BY REV A ON SHEET 3

DESIGNED		DRAWN		DATE		CHECKED		DATE		STREAM		LOCATION		HIGHWAY		FILE		SHEET		DRAWING	
WJW		WJW		98-01-20		S. J. G.		98-01-20										1 OF 1		S-1626-98	
APPROVED										<b>Alberta TRANSPORTATION AND UTILITIES</b> TECHNICAL STANDARDS BRANCH <b>TYPE I STRIP SEAL</b> <b>DECK JOINT</b> <b>WITH SNOW PLOW GUARD</b>											
98-10-02 SECTION D ADDED, GENERAL UPDATE REV DATE REVISIONS CHECKED BY DATE																					