

**DECK JOINT PLAN**  
1:20

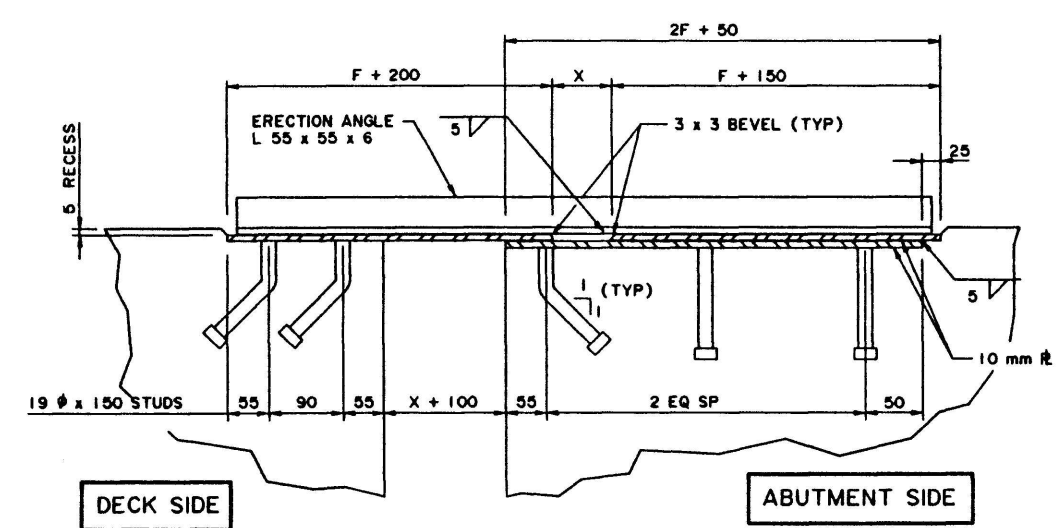

**SECTION - CURB PLATES**  
1:5

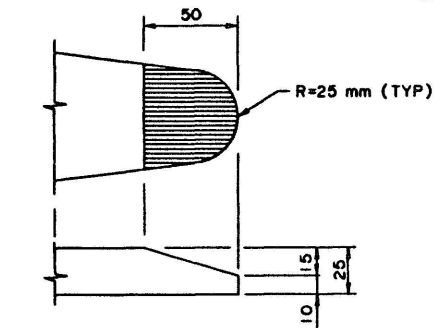

**FINGER BEVEL DETAIL**  
1:2

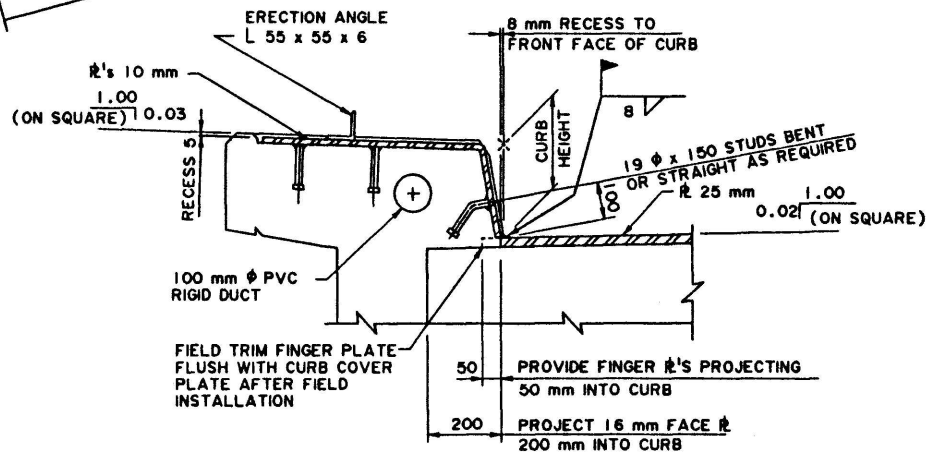

**SECTION - DECK SIDE**  
1:10

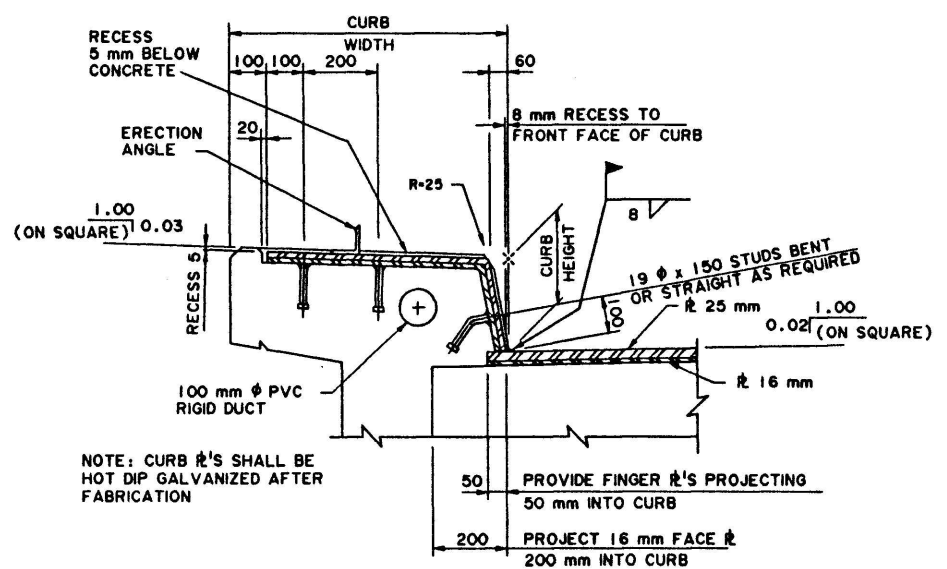

**SECTION - ABUT SIDE**  
1:10

**GENERAL NOTES**

- ALL DIMENSIONS ARE IN MILLIMETRES UNLESS NOTED OTHERWISE.
- $X@-5^{\circ}C = (1/2 \text{ CALCULATED MOVEMENT}) + 50 \text{ mm}$ .
- $F = 2(X@-5^{\circ}C) + 100 \text{ mm}$ .
- FOR JOINT GAP SETTING TABLE, SEE SITE SPECIFIC DRAWINGS.

**MATERIALS AND FABRICATION**

- ALL REQUIREMENTS OF THE CURRENT BRIDGE CONSTRUCTION SPECIFICATION, SECTION 6, STRUCTURAL STEEL SHALL BE MET.
- ALL STEEL FOR DECK JOINT ASSEMBLY SHALL CONFORM TO CSA G40.21M-350A UNLESS NOTED OTHERWISE. CURB PLATES SHALL CONFORM TO CSA G40.21M-300W AND SHALL BE HOT-DIP GALVANIZED.
- STAINLESS STEEL TROUGH AND BOLTS SHALL BE AISI TYPE 316. STAINLESS STEEL SHALL BE PROTECTED BY A PROTECTIVE FILM FROM ABRASION OR SCRATCHING AT ALL TIMES DURING SHIPPING AND CONSTRUCTION.
- GALVANIZING SHALL CONFORM TO THE REQUIREMENTS OF CSA STANDARDS G164.
- ALL WELDING SHALL CONFORM TO THE REQUIREMENTS OF AWS SPECIFICATION D1.5.
- FIBRE REINFORCED NEOPRENE SHALL BE "AMERICAN BILTRITE AB 3210 NEO/NYLON" SHEET OR APPROVED EQUIVALENT. DRIP SHEET SHALL BE SHOP FABRICATED TO REQUIRED SIZE. BOLT HOLES SHALL BE SHOP PUNCHED.
- SUPPLY ROADWAY PORTION OF DECK JOINT ASSEMBLY IN ONE PIECE.
- EXPOSED FACES OF 16 mm VERTICAL PLATES AND THE 10x50 DRIP BAR SHALL BE BLAST CLEANED AND PAINTED WITH THE FOLLOWING PAINT SYSTEM: ONE PRIMER COAT OF WASSER ZINC PRIMER MC-ZINC, ONE INTERMEDIATE COAT OF MC FERROX B, AND ONE TOP COAT OF MC FERROX A, OR AN APPROVED EQUIVALENT. ALL PAINT COATS TO HAVE A DRY FILM THICKNESS OF 100 um.
- ALIGNMENT MARK TO BE SCRIBED ACROSS TOP SURFACE OF JOINT PARALLEL TO CENTRELINE ROADWAY AT EACH END AFTER APPROVAL OF SHOP ASSEMBLY BY CONSULTANT. JOINT TO BE SHIPPED WITH ASSEMBLY SET FOR GAP AT +15°C. RESET GAP IN THE FIELD TO SUIT THE STRUCTURE TEMPERATURE.

**TOLERANCES**

- THE FINGER JOINT SHALL BE SHOP ASSEMBLED IN A RELAXED CONDITION WITH ERECTION ANGLE BOLTS TIGHT ONLY. THE ASSEMBLY SHALL BE PROPERLY SUPPORTED THROUGHOUT ITS LENGTH FOR CHECKING THE TOLERANCES. THE TIP OF EACH FINGER SHALL BE CHECKED FOR FULL CONTACT WITH THE FINGER SUPPORT PLATE AT THE -5°C AND +15°C GAP SETTINGS. THE REST OF THE CONTACT AREA BETWEEN THE FINGER PLATE AND THE FINGER SUPPORT PLATE MAY HAVE A GAP NOT EXCEEDING 1 mm.
- FINGER PLATES AND BOTTOM FINGER SUPPORT PLATE SHALL BE FLAT AND TRUE, THE PERMISSIBLE VARIATION FOR FLATNESS IN TRANSVERSE DIRECTION (PARALLEL TO TRAFFIC) IS 2 mm/m.
- TOLERANCE FOR STRAIGHTNESS SHALL BE MEASURED OVER THE LENGTH OF THE ASSEMBLY BETWEEN THE CROWN AND THE GUTTER LINE. DEVIATION FROM STRAIGHTNESS IN A VERTICAL PLANE SHALL NOT EXCEED ± 5 mm. VARIATION IN THE JOINT GAP SHALL NOT EXCEED ± 3 mm. HORIZONTAL SWEEP SHALL NOT EXCEED 6 mm.
- IN A FULLY CLOSED POSITION, THE FINGERS SHALL HAVE A UNIFORM SIDE CLEARANCE OF 3 mm ± 1.5 mm.

**INSTALLATION PROCEDURE**

1. THE EXPANSION ASSEMBLY SHALL BE INSTALLED AFTER COMPLETION OF THE DECK POUR.
2. CUT 20 mm SUPPORT BARS TO THE REQUIRED ELEVATION SUCH THAT THE DECK JOINT ASSEMBLY WILL REST ON THE BARS AT THE CORRECT GRADE AND CROWN. SET ELEVATIONS BY INSTRUMENT. ERECT ASSEMBLY ON TO SUPPORT BARS AND OTHER SUPPORTS AS NECESSARY. ADJUST GIRDER SUPPORT CLIPS AS REQUIRED.
3. SET GAP TO SUIT STRUCTURE TEMPERATURE. THE INSTALLATION TEMPERATURE MAY BE ASSUMED AS THE MEAN SHADE AIR TEMPERATURE AT THE STRUCTURE ESTABLISHED OVER A PERIOD PRIOR TO INSTALLATION TAKEN AS 48 HOURS FOR A CONCRETE STRUCTURE AND 24 HOURS FOR A STEEL STRUCTURE.
4. SECURE ROADWAY PORTION OF THE EXPANSION ASSEMBLY TO THE GIRDERS AND BACKWALL BY BOLTING/WELDING. THE FINGERPLATES MUST BE KEPT IN FULL BEARING (SEE TOLERANCE REQUIREMENTS) WITH THE BOTTOM PLATE AT ALL TIMES. THE ATTACHMENT MUST BE STRONG ENOUGH TO MAINTAIN THE CORRECT GAP, GRADE AND ALIGNMENT OF THE ASSEMBLY UNTIL AFTER CONCRETE PLACEMENT. IT IS THE CONTRACTOR'S RESPONSIBILITY TO PROVIDE SUPPORTS ADDITIONAL TO THOSE SHOWN ON THE DRAWINGS TO ASSURE THESE REQUIREMENTS ARE MET.
5. AFTER ASSEMBLY IS SECURED, LOOSEN BOLTS IN SLOTTED HOLES IN ERECTION ANGLES SUFFICIENTLY TO ALLOW TEMPERATURE MOVEMENT WITHOUT DAMAGING BRIDGE COMPONENTS. CAREFULLY OBSERVE THAT CLAMPED PORTIONS DO NOT MOVE OR DEFORM WHEN BOLTS ARE LOOSENED.
6. CHECK ASSEMBLY GRADE, ELEVATION AND FINGERPLATE BEARING. PROCEED WITH CONCRETE PLACEMENT AFTER APPROVAL BY THE CONSULTANT. TEMPORARILY PLUG ALL GROUT HOLES PRIOR TO PLACING CONCRETE.
7. AFTER CONCRETE HAS SET FOR A MINIMUM OF 12 HOURS, REMOVE ERECTION ANGLES.
8. STARTING AT ONE END, PRESSURE GROUT THE VOID USING A 40 MPa NON-SHRINK GROUT AS FOLLOWS:
  - a) PLACE NOZZLE IN THE FIRST HOLE AND WITH ALL OTHER HOLES PLUGGED, DEVELOP FULL PUMP PRESSURE (400kPa). FAILURE TO DEVELOP FULL PRESSURE INDICATES A LEAK.
  - b) OPEN THE SECOND HOLE AND ALLOW GROUT TO FLOW FREELY.
  - c) OBSERVE THE GROUT AS IT FLOWS THROUGH THE HOLE. STOP PUMPING WHEN GROUT IS FREE OF ENTRAPPED AIR AND WATER.
  - d) PLUG FIRST HOLE, PLACE THE NOZZLE IN THE SECOND HOLE, AND REPEAT THIS PROCESS UNTIL THE FULL LENGTH OF THE ASSEMBLY IS GROUTED IN THIS PROGRESSIVE MANNER.
  - e) REMOVE ANY GROUT SPILLAGE ON BRIDGE COMPONENTS.
9. REMOVE ALL FORMWORK AND PLUGS, CLEAN EXCESS CONCRETE AND DEBRIS FROM ASSEMBLY.
10. CAST IN PLACE THE CURB PORTIONS OF THE DECK JOINT ASSEMBLY.

**SUPERSEDED BY S-1638**  
**REVISION 1, 2005-11-08**

APPROVED		Albarta TRANSPORTATION AND UTILITIES TECHNICAL STANDARDS BRANCH	
 EXECUTIVE DIRECTOR TECHNICAL STANDARDS BRANCH		STANDARD FINGER PLATE DECK JOINT ASSEMBLY GENERAL LAYOUT	
DATE: May 4, 1999		DRAWING: S-1638	
DESIGNED	DRAWN	DATE	CHECKED
RY	WJW	99-02-06	AW
DATE	DATE	DATE	DATE
	April 29/99		
REV	DATE	REVISIONS	BY
STREAM	LOCATION	HIGHWAY	FILE
SHEET	DRAWING		
1 of 3	S-1638		