

GENERAL NOTES

1. ALL DIMENSIONS ARE IN MILLIMETRES UNLESS NOTED OTHERWISE.
2. RAILING CONFIGURATION IS BASED ON A RAILING CONFIGURATION THAT HAS BEEN CRASH TESTED AND MEETS THE REQUIREMENTS OF PERFORMANCE LEVEL 1 OF THE AASHTO GUIDE SPECIFICATIONS FOR BRIDGE RAILING, 1989.
3. RAILING SHALL NOT BE USED WITH CURB.
4. DESIGN OF DECK REBAR SHALL BE CARRIED OUT ON A SITE SPECIFIC BASIS TO DEVELOP THE CAPACITY OF THE BRIDGERAIL POSTS.

FABRICATION

1. BRIDGERAIL, INCLUDING APPROACH RAIL TRANSITION, SHALL CONFORM TO THE CURRENT REQUIREMENTS OF THE SPECIFICATIONS FOR BRIDGE CONSTRUCTION SECTION 12 - BRIDGERAIL AND SECTION 14 - GUARDRAIL.
2. ALL PLATE STEEL AND STRUCTURAL SHAPES SHALL CONFORM TO CSA G40.21 GRADE 300W OR ASTM A36.
3. ALL ANCHOR BOLTS SHALL CONFORM TO AISI 4140 ANNEALED AND SHALL HAVE A MINIMUM YIELD STRENGTH (AT 0.2% OFFSET) OF 420 MPa AND A MINIMUM ULTIMATE TENSILE STRENGTH OF 650 MPa. ALL NUTS AND WASHERS SHALL CONFORM TO A325.
4. ALL W-BEAM AND THRIE BEAM GUARDRAIL (INCLUDING W-THRIE BEAM TRANSITION SECTION) SHALL HAVE A MINIMUM YIELD STRENGTH OF 345 MPa.
5. TIMBER POSTS AND SPACERS SHALL BE COAST DOUGLAS FIR OR PACIFIC COAST HEMLOCK CONFORMING TO THE STRESS GRADE "SELECT STRUCTURAL POSTS AND TIMBERS" (NLGA PARAGRAPH 131 a).
6. ALL WELDING SHALL CONFORM TO CURRENT AWS SPECIFICATION D1.5.
7. ALL STEEL MATERIALS SHALL BE HOT-DIP GALVANIZED AFTER FABRICATION IN ACCORDANCE WITH CSA G164 UNLESS NOTED OTHERWISE.

ERECTION

1. BRIDGERAIL ANCHOR BOLTS SHALL BE TIGHTENED AN ADDITIONAL 1/2 TURN OF THE NUT PAST THE "SNUG TIGHT" CONDITION.
2. ALL POSTS SHALL BE PERPENDICULAR TO GRADE.
3. ALL DIMENSIONS ARE MEASURED PARALLEL TO TOP OF BRIDGE DECK AND ALONG THE CENTRELINE OF ANCHOR BOLT ASSEMBLIES.
4. LINE AND ELEVATION OF RAIL SHALL HAVE A TOLERANCE OF 6 mm.
5. ALL NON-STANDARD GUARDRAIL LENGTHS SHALL BE SAW CUT TO SUIT AND ALL NON-STANDARD GUARDRAIL HOLES SHALL BE DRILLED. FLAME CUTTING OF GUARDRAIL SHALL NOT BE ALLOWED. APPLY TWO COATS OF ZINC RICH PAINT ON AREAS DAMAGED BY SAW CUTTING OR DRILLING.

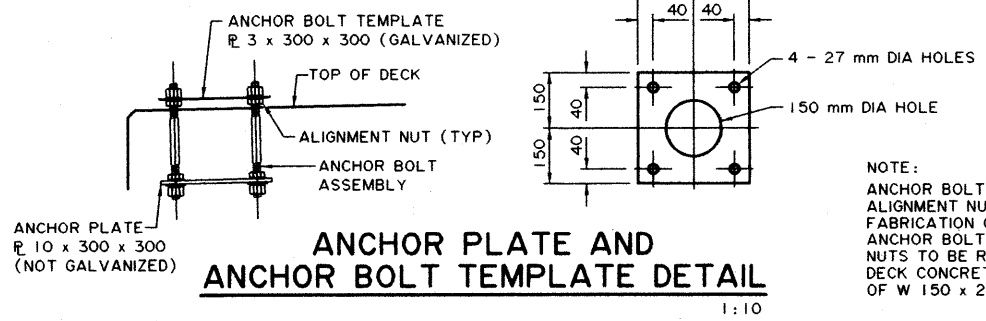
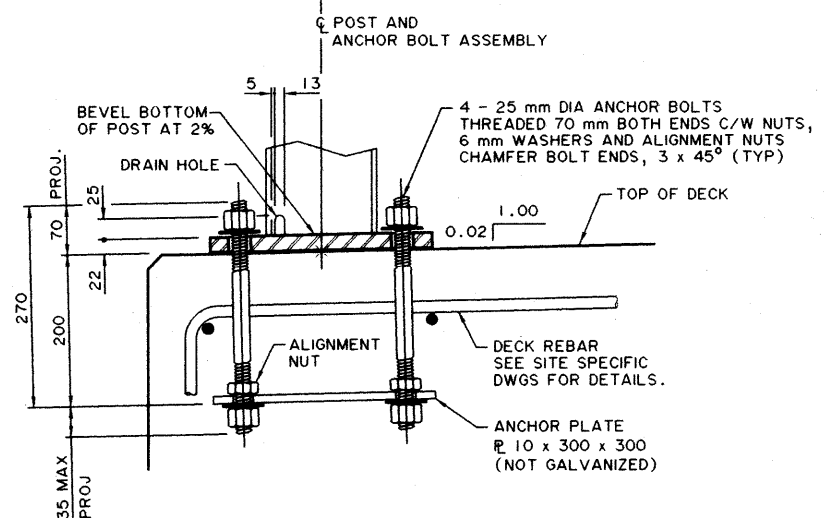
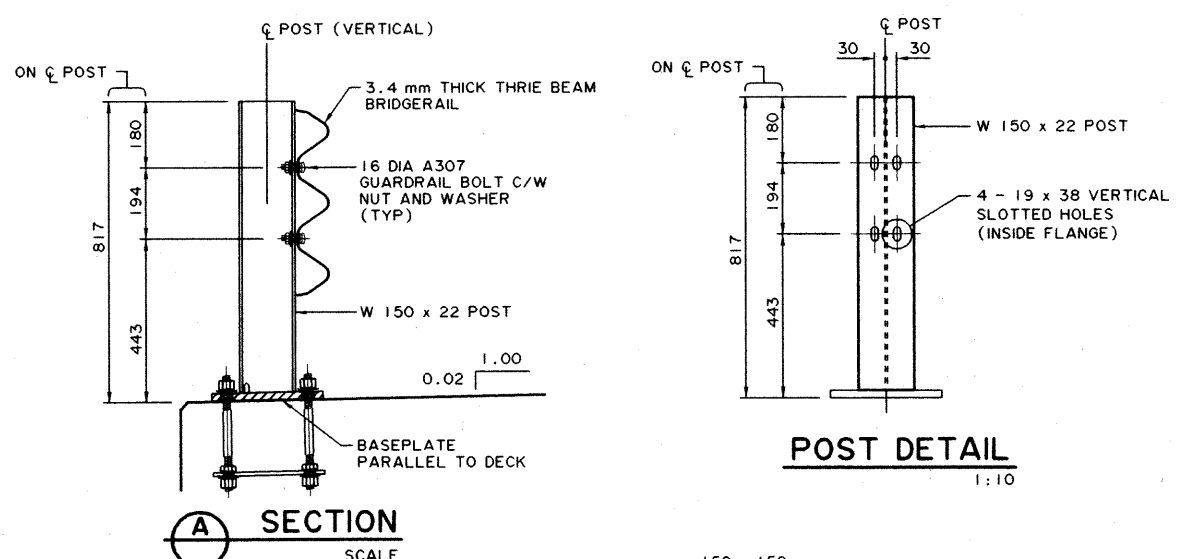
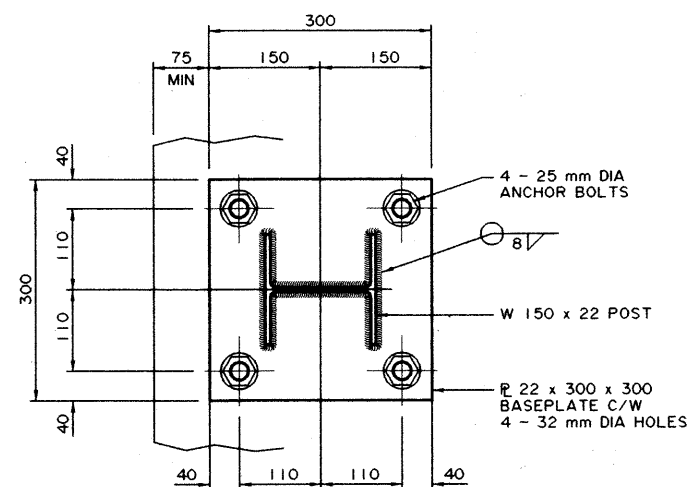

NOTE:
ANCHOR BOLT TEMPLATE C/W NUTS AND ALIGNMENT NUTS TO BE INSTALLED DURING FABRICATION OF ANCHOR BOLT ASSEMBLIES. ANCHOR BOLT TEMPLATE AND ALIGNMENT NUTS TO BE REMOVED AFTER PLACING OF DECK CONCRETE AND PRIOR TO INSTALLATION OF W 150 x 22 POST.

ANCHOR BOLT ASSEMBLY DETAIL

NOTE:
ANCHOR BOLT ASSEMBLY SHALL BE MINIMUM 25 mm CLEAR FROM BOTTOM OF DECK.

0705-103-00-3 / S-1652-00.DGN

<p>UMA Engineering Ltd. Engineers, Planners & Surveyors</p>	<p>PERMIT TO PRACTICE UMA ENGINEERING LTD. Signature: <i>[Signature]</i> Date: <i>Nov 21, 2000</i> PERMIT NUMBER: P329 The Association of Professional Engineers, Geologists and Geophysicists of Alberta</p>	<p>DESIGNER PROFESSIONAL ENGINEER ALBERTA <i>[Signature]</i> DATE: <i>Nov 21, 2000</i></p>	<p>CHECKER PROFESSIONAL ENGINEER ALBERTA <i>[Signature]</i> DATE: <i>Nov 21, 2000</i></p>	<table border="1"> <tr><th>REV</th><th>DATE</th><th>REVISIONS</th><th>BY</th></tr> <tr><td> </td><td> </td><td> </td><td> </td></tr> </table>	REV	DATE	REVISIONS	BY					<p>RECOMMENDED DIRECTOR BRIDGE ENGINEERING <i>[Signature]</i> APPROVED EXECUTIVE DIRECTOR TECHNICAL STANDARDS BRANCH <i>[Signature]</i> DATE: <i>22 Nov 00</i></p>	<p>Alberta INFRASTRUCTURE</p> <p>PL-1 THRIE BEAM BRIDGERAIL</p>
					REV	DATE	REVISIONS	BY						
<p>DATE: 2000-03-27</p>	<p>SHEET OF</p>	<p>DRAWING S-1652-00</p>												