

BAR LIST: FOR SQUARE GIRDER							
MARK	SIZE	NO	TYPE	X	Y	LENGTH	MASS
G1001	10	29	A	1 125	300	1 725	39
G1002	10	5	STR			6 000	24
G1003	10	29	B	1 125		2 220	51
G1004	10	27	B	420		1 520	32
G1005	10	2	STR			5 900	9
G1006	10	6	D			1 080	5
G1007	10	2	A	1 000	300	1 600	3
G1025	10	2	C			670	1

TOTAL kg : 164

NOTE:
BEND REINFORCING BAR WHERE NECESSARY TO ACCOMMODATE CHANNEL CONNECTORS. STIRRUP SPACING TO BE MAINTAINED.

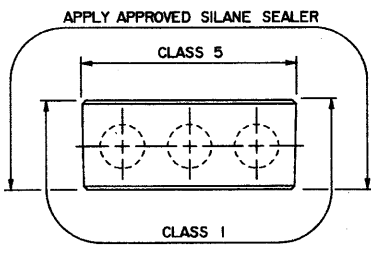
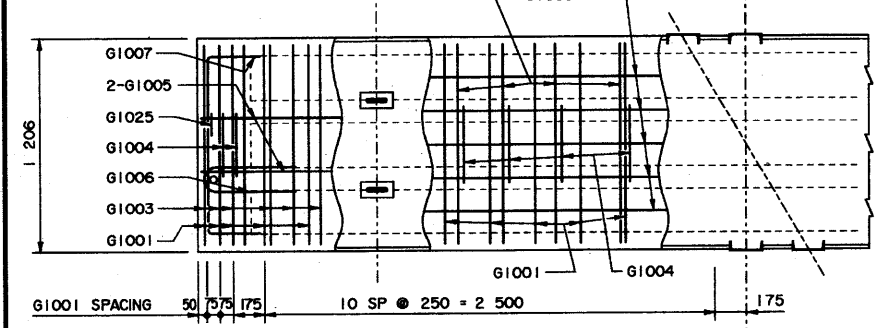

NOTE:
• 2 - 13 φ, 7 WIRE STRANDS. 750 MIN EMBEDMENT EACH END.
• AFTER GIRDERS ARE ERECTED, LIFTING STRANDS ARE TO BE CUT-OFF FLUSH WITH BOTTOM OF POCKET. POCKET TO BE FILLED WITH AN LTH MATERIAL APPROVED IN ACCORDANCE WITH BRIDGE MATERIALS SPEC B391.

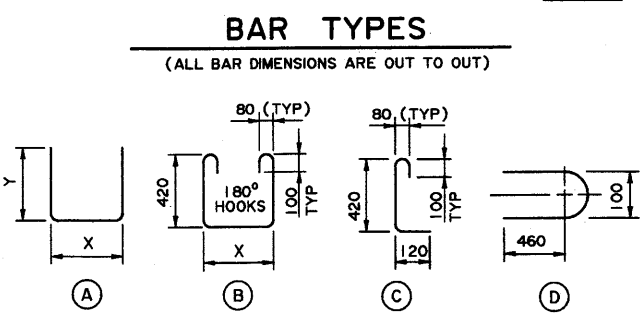

GENERAL NOTES

- ALL DRAWING REFERENCES ARE TO CURRENT DRAWINGS.
- DESIGN**
- CAN/CSA-S6-88 SPECIFICATIONS EXCEPT AS MODIFIED BELOW:
 - ALLOWABLE TENSION AT MIDSPAN IS 40% OF MODULUS OF RUPTURE (SEVERE EXPOSURE CONDITIONS).
 - NO TENSION ALLOWED IN DECK SURFACE.
- **LOADING:**
 - LIVE LOAD - CAN/CSA-S6-88; CS-750 ONE WHEEL LINE PER GIRDER
 - DEAD LOAD - GIRDER = 0.93 t/m
 - WEARING SURFACE = 0.24 t/m

- MATERIALS**
- CONCRETE SHALL CONTAIN SILICA FUME AND BE MADE OF LIGHTWEIGHT COARSE AGGREGATE AND NATURAL SAND FINES. UNIT WEIGHT OF SEMI-LIGHTWEIGHT CONCRETE SHALL BE 1920 kg/m³.
- 28 DAY CONCRETE STRENGTH - 35 MPa
- RELEASE STRENGTH - 28 MPa
- PRESTRESSING STEEL SHALL BE 13 φ, 7 WIRE LOW RELAXATION STRAND (f_{pu} = 1 860 MPa).
- REINFORCING STEEL SHALL BE GRADE 400W (YIELD STRENGTH OF GRADE 300 USED IN DESIGN TO ALLOW TACK WELDING OF SHEAR REINFORCEMENT).

- FABRICATION**
- GIRDERS SHALL CONFORM TO THE CURRENT REQUIREMENTS OF THE SPECIFICATIONS FOR BRIDGE CONSTRUCTION SECTION 7 - PRECAST CONCRETE UNITS.
- FORCE IN PRESTRESSING STEEL:
 - INITIAL TENSIONING LOAD = 129 kN/STRAND
 - DESIGN LOAD AFTER LOSSES = 111 kN/STRAND
- ALL GALVANIZING SHALL CONFORM TO ASTM SPEC A123.
- BEND OR SHIFT REINFORCING WHERE REQUIRED TO CLEAR GIRDER CONNECTORS AND LIFTING HOOK ASSEMBLIES. STIRRUP SPACING IS TO BE MAINTAINED. FOR CONNECTOR AND LIFTING HOOK LOCATIONS SEE DWG S-1665-01

- ERECTION**
- ANY FREE SPACE BETWEEN CONNECTORS SHALL BE FILLED WITH DROP-IN WASHERS.
- CALCULATED MASS OF ONE GIRDER IS 5.84 t.
- WORK THESE DRAWINGS TOGETHER : S-1664-01 AND S-1665-01

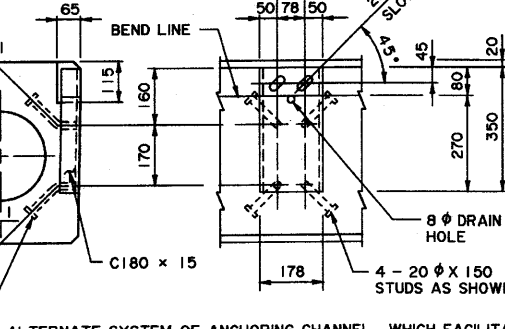
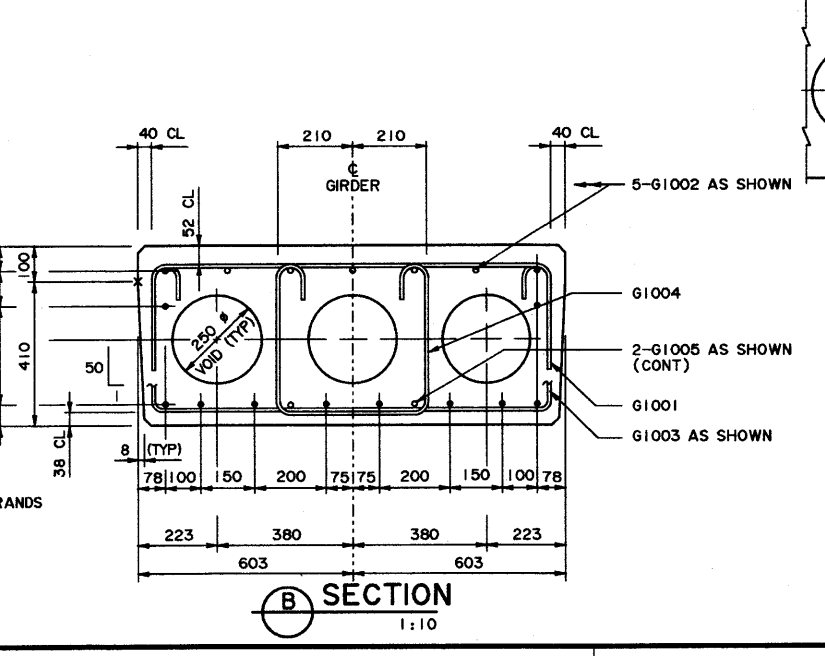
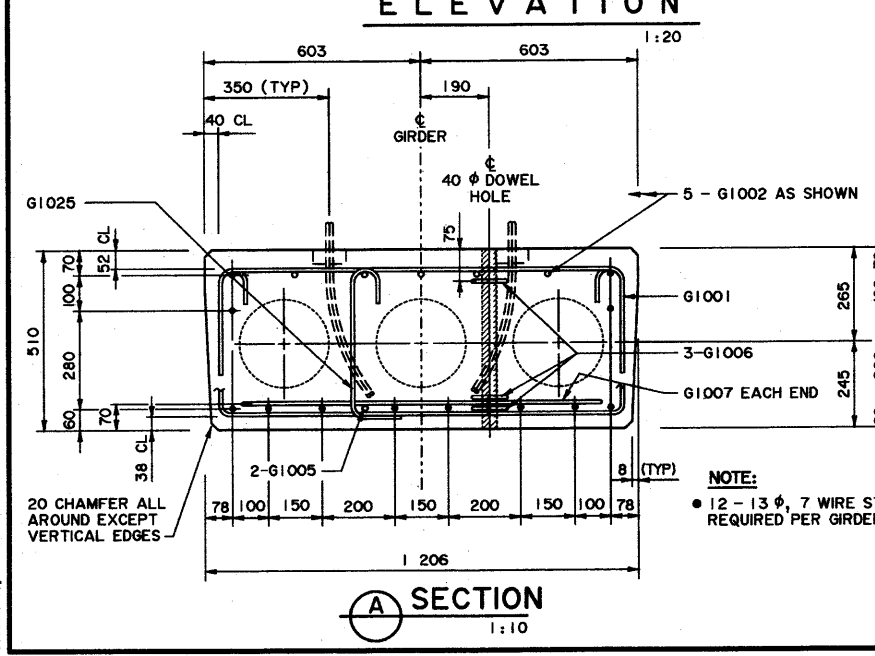
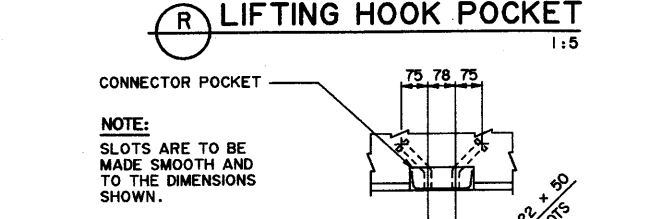
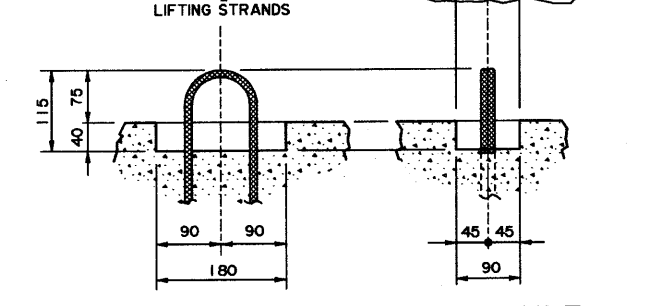
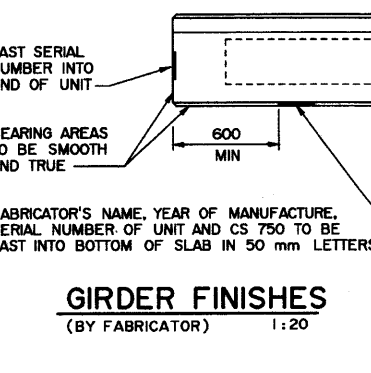
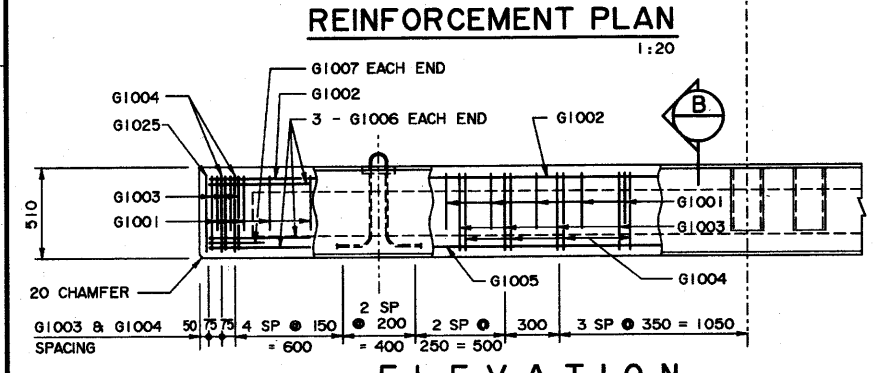

GIRDER CONNECTORS 1:10

REV	DATE	REVISIONS	BY
DESIGNER		CHECKER	

RECOMMENDED DIRECTOR BRIDGE ENGINEERING

Albata TRANSPORTATION

APPROVED EXECUTIVE DIRECTOR TECHNICAL STANDARDS BRANCH

PRESTRESSED CONCRETE 6.10 m TYPE SC-510 INTERIOR GIRDER

DATE 2001-04-30 SHEET 1 of 2 DRAWING S-1664-01

S1664-01-01 PLOTTED 2001-04-30