

DATA FOR STANDARD SL PRECAST GIRDER BRIDGES - ABUTMENTS

CLEAR ROADWAY (GIRDERS / SPAN)		R	8 940 (8)					10 160 (9)					11 370 (10)					12 590 (11)					13 810 (12)					15 020 (13)					
ABUTMENT TYPE			BACKWALL		SPILL THROUGH			BACKWALL		SPILL THROUGH			BACKWALL		SPILL THROUGH			BACKWALL		SPILL THROUGH			BACKWALL		SPILL THROUGH								
SKEW			0°	0°	15°	30°	45°	0°	0°	15°	30°	45°	0°	0°	15°	30°	45°	0°	0°	15°	30°	45°	0°	0°	15°	30°	45°						
OVERALL LENGTH		A	12 740	9 920	10 270	11 455	14 029	13 960	11 140	11 533	12 863	15 754	15 170	12 350	12 786	14 261	17 466	16 390	13 570	14 049	15 669	19 191	17 610	14 790	15 312	17 078	20 916	18 820	16 000	16 564	18 475	22 627	
CROWN		B	127	99	99	99	99	140	111	111	111	152	152	124	124	124	164	164	136	136	136	136	176	148	148	148	148	188	160	160	160		
DIFFERENTIAL FOR ROADWAY GRADE OF		1%	C	0	0	27	57	99	0	0	30	64	111	0	0	33	71	124	0	0	36	78	136	0	0	40	85	148	0	0	43	92	160
		2%	C	0	0	53	115	198	0	0	60	129	223	0	0	66	143	247	0	0	73	157	271	0	0	79	171	296	0	0	86	185	320
		3%	C	0	0	80	172	298	0	0	90	193	334	0	0	99	214	371	0	0	109	235	407	0	0	119	256	444	0	0	129	277	480
NUMBER - LOAD BEARING			6	6	6	6	6	7	7	7	7	8	8	8	8	8	9	9	9	9	9	9	9	9	9	9	9	10	10	10	10		
SPACING		D	1 642	1 642	1 700	1 896	2 322	1 572	1 572	1 627	1 815	2 223	1 520	1 520	1 574	1 755	2 150	1 482	1 482	1 534	1 711	2 096	1 635	1 635	1 693	1 888	2 312	1 588	1 588	1 644	1 834	2 246	
END DISTANCES		E	855	855	885	987	1 209	855	855	885	987	1 209	855	855	885	987	1 209	855	855	885	987	1 209	855	855	885	987	1 209	855	855	885	987	1 209	
WINGWALL PILE LOCATION		F	1 665	1 623	1 680	1 874	2 295	1 664	1 693	1 753	1 955	2 394	1 665	1 745	1 807	2 015	2 468	1 667	1 783	1 846	2 059	2 522	1 665	1 630	1 688	1 882	2 305	1 664	1 677	1 736	1 936	2 372	
WINGWALL PROJECTION		G	600	600	621	693	849	600	600	621	693	849	600	600	621	693	849	600	600	621	693	849	600	600	621	693	849	600	600	621	693	849	
NUMBER OF DOWELS PER LINE			16	16	16	16	16	18	18	18	18	18	20	20	20	20	22	22	22	22	22	22	24	24	24	24	24	26	26	26	26		
EXTERIOR GIRDER LOCATION FROM $\phi$ BRIDGE		M	4 859	4 859	5 030	5 611	6 872	5 467	5 467	5 660	6 313	7 732	6 075	6 075	6 289	7 015	8 591	6 683	6 683	6 919	7 717	9 451	7 291	7 291	7 548	8 419	10 311	7 899	7 899	8 178	9 121	11 171	

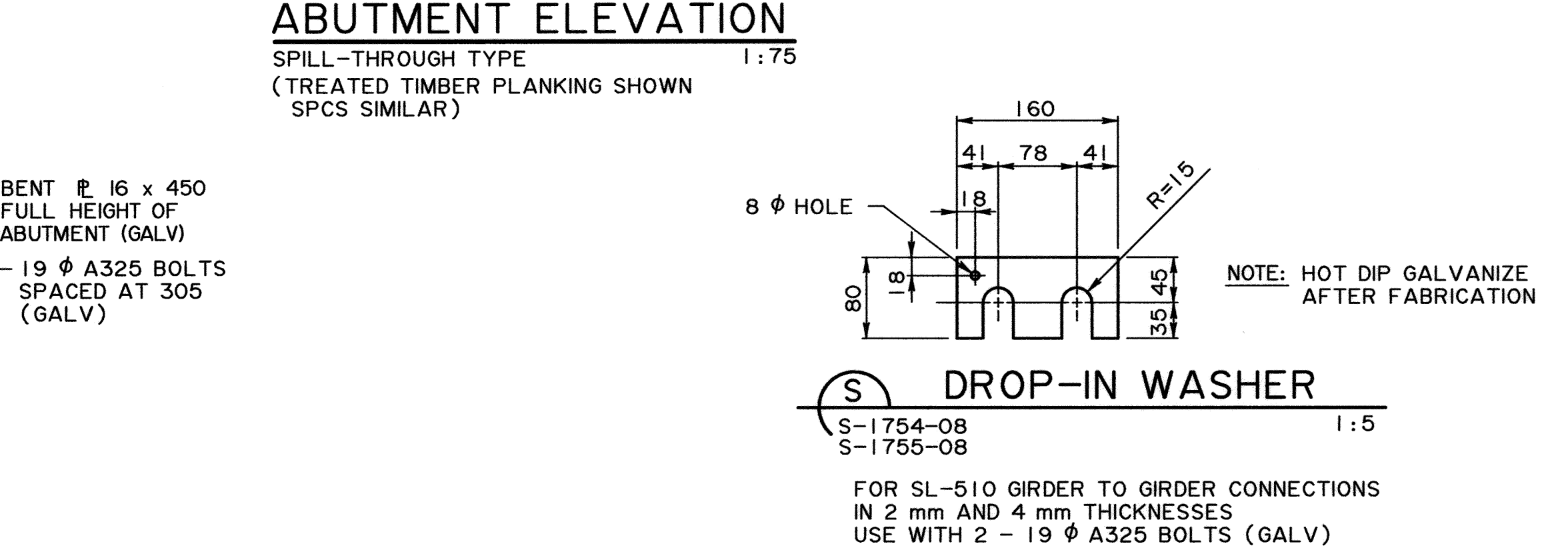
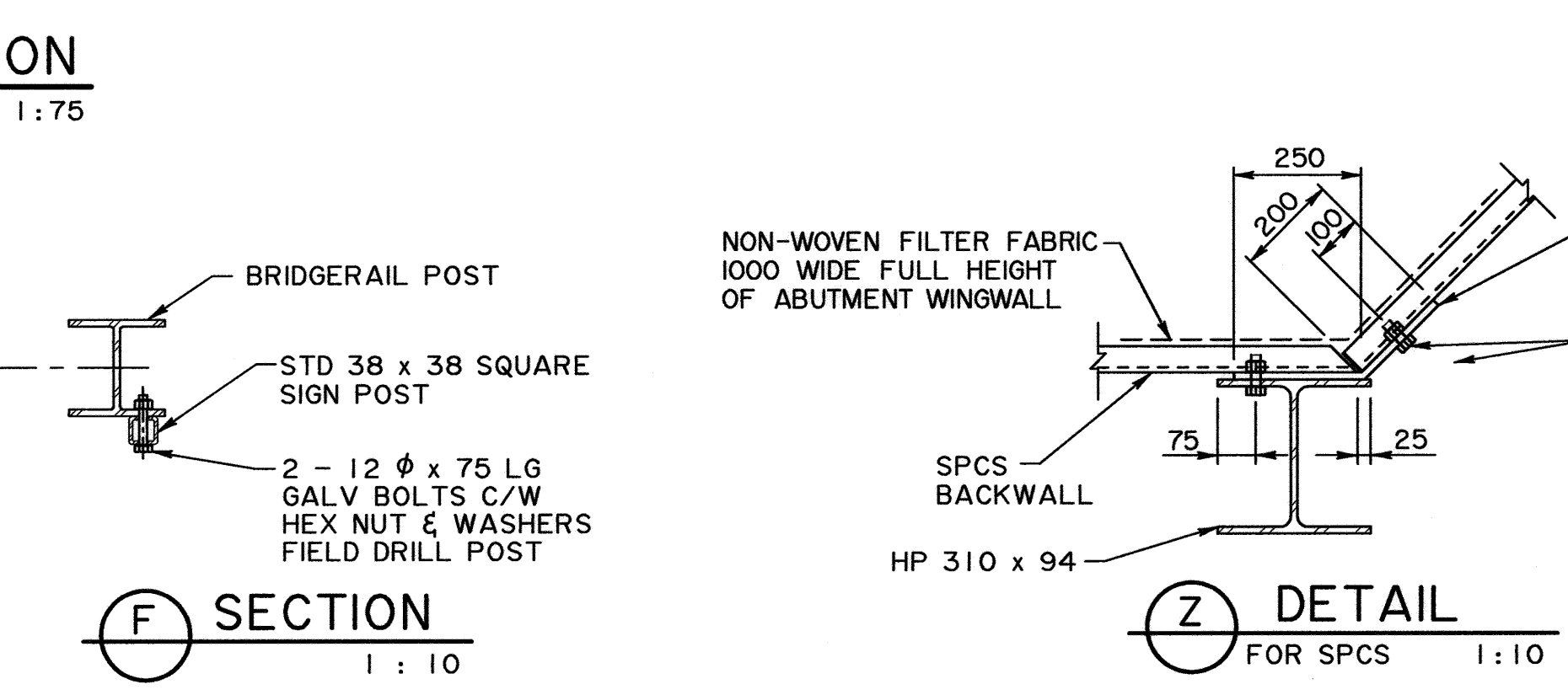
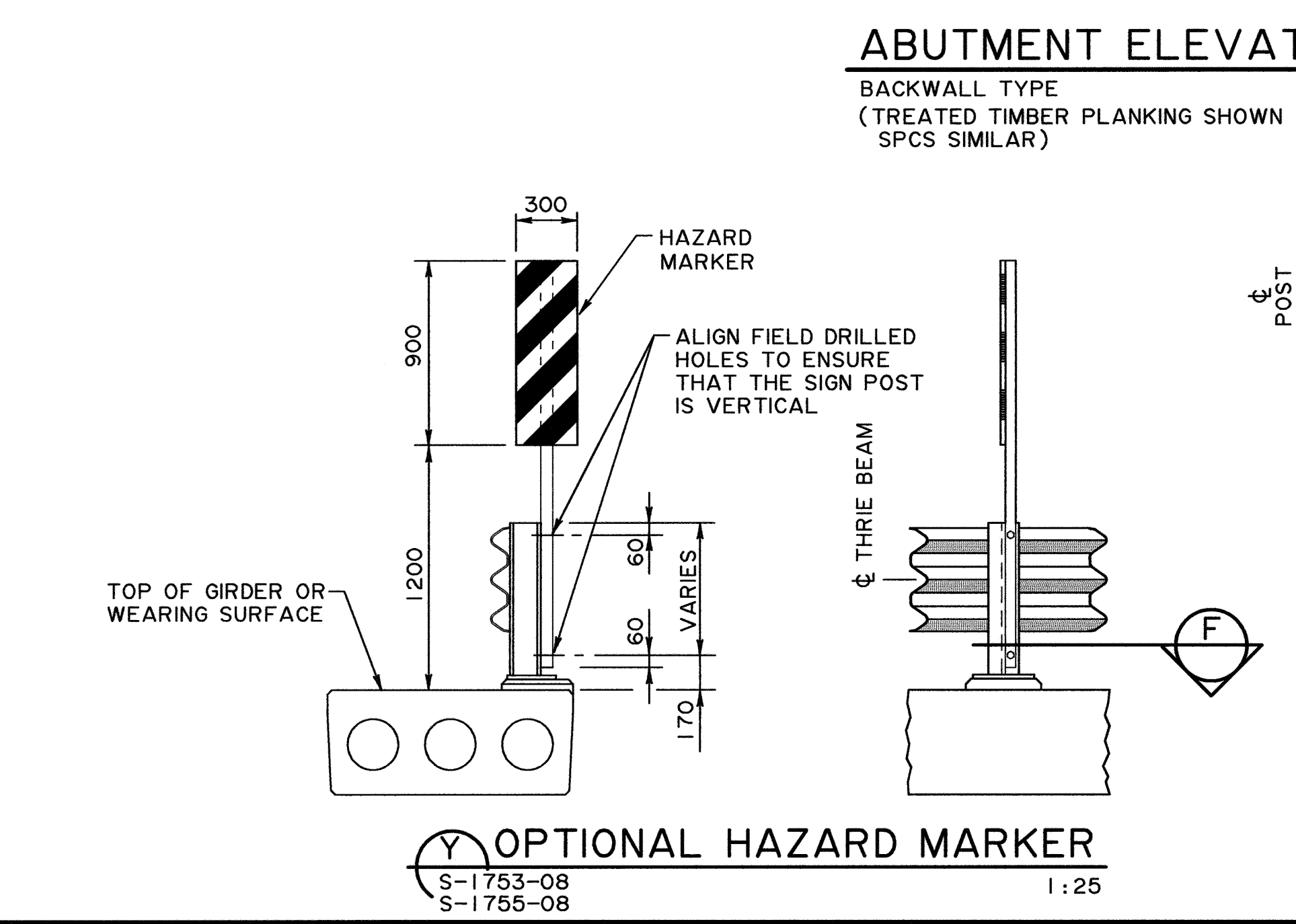
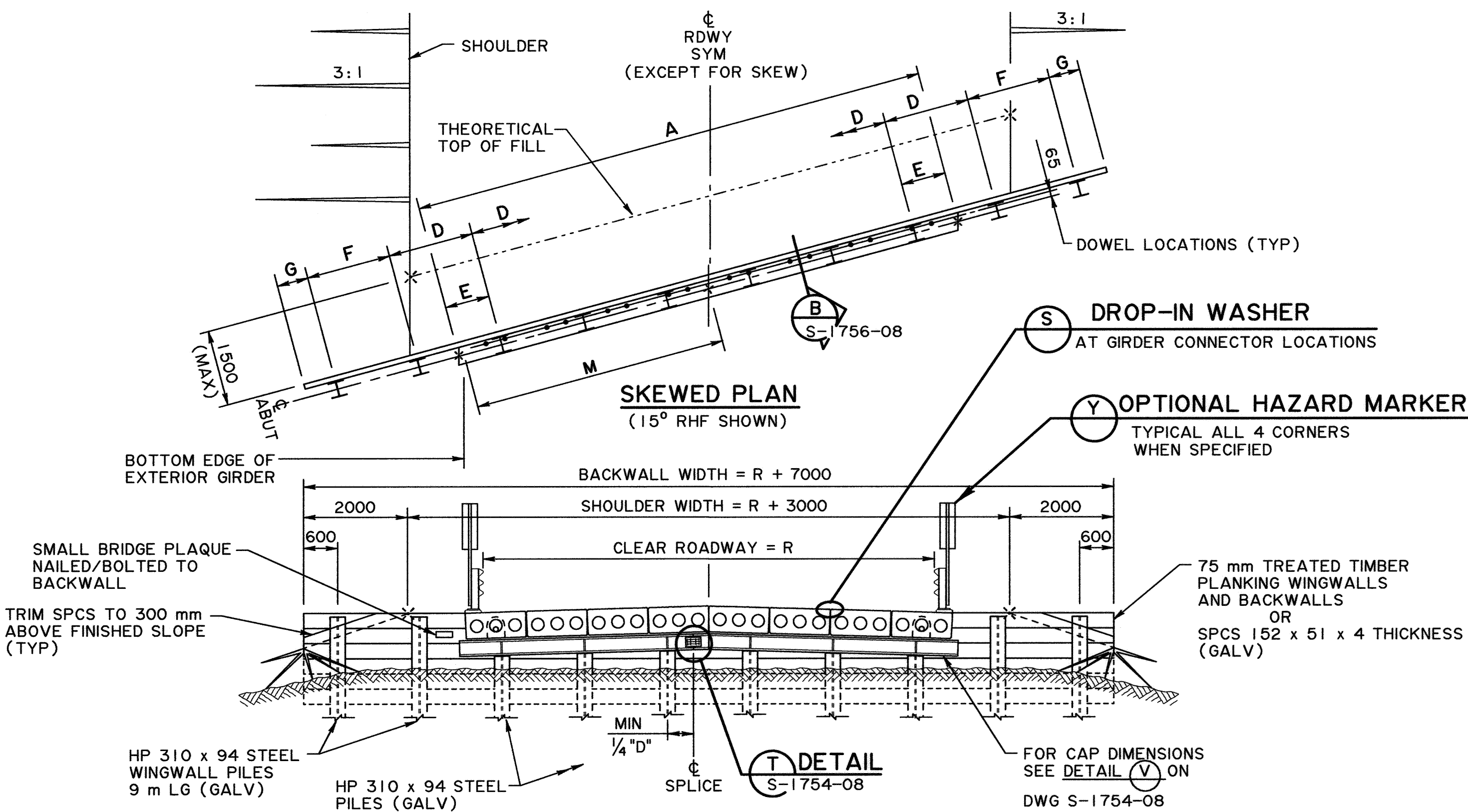
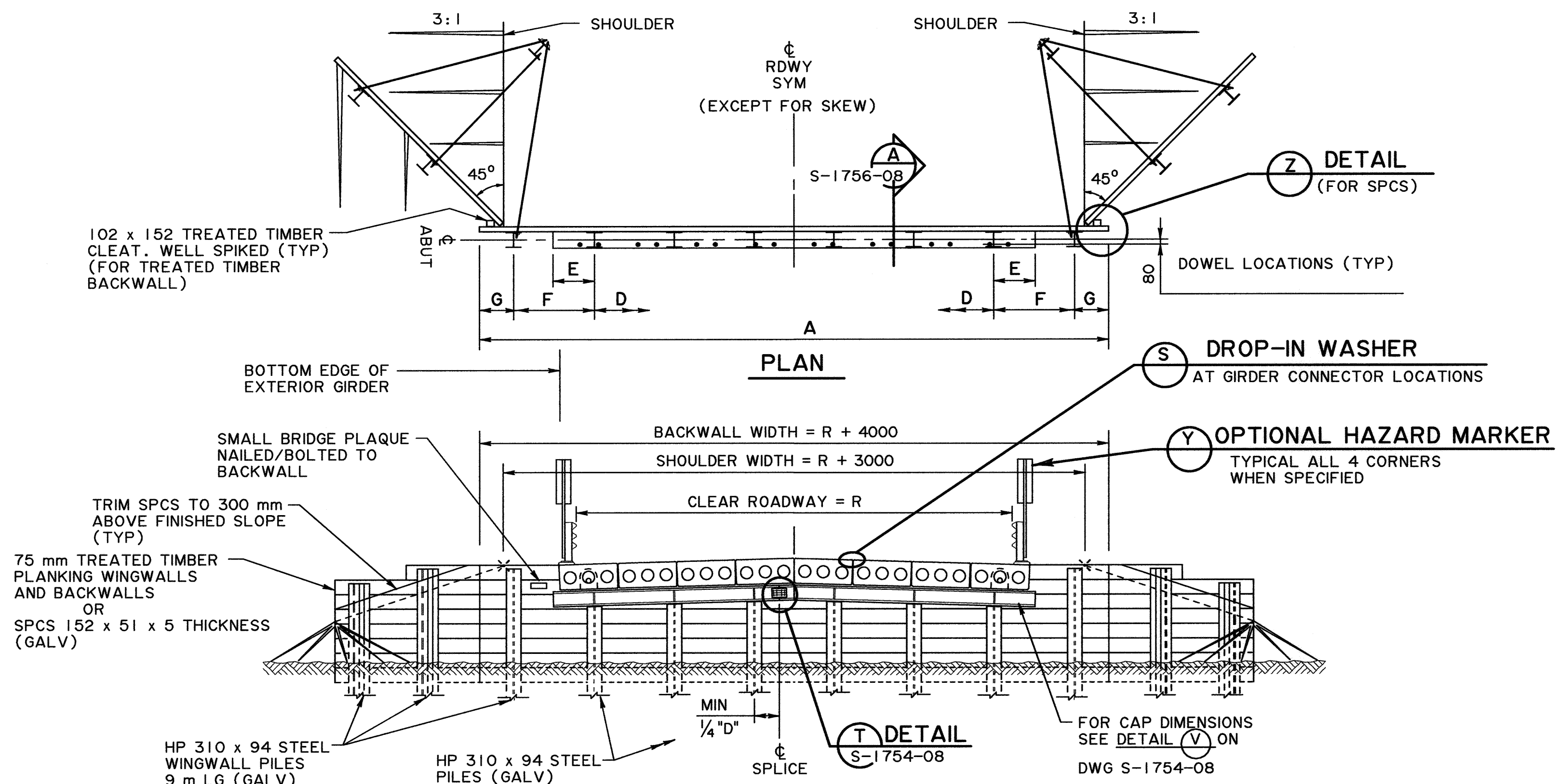

	PERMIT TO PRACTICE MOST ENGINEERING (2001) LTD. Signature: <i>[Signature]</i> Date: <i>Aug 15, 2008</i> PERMIT NUMBER: P 8859 The Association of Professional Engineers, Geologists and Geophysicists of Alberta	DESIGNER  DATE: <i>Aug 15, 2008</i>	CHECKER  DATE: <i>08/15/2008</i>	RECOMMENDED DIRECTOR BRIDGE ENGINEERING  APPROVED EXECUTIVE DIRECTOR TECHNICAL STANDARDS BRANCH  DATE: <i>Sept 8/08</i>	Alberta Transportation <b>SL PRECAST GIRDER BRIDGES WITH STEEL SUBSTRUCTURES</b> <b>SHEET 3</b> AT BAR CODE: _____ DATE: 2008-08-18 SHEET: 3 of 4 DRAWING: S-1755-08
	REVISIONS REV: _____ DATE: _____ REVISIONS: _____ BY: _____				