

= GENERAL NOTES =

DESIGN

Specifications: Recommendations of the A.C.I.-A.S.C.E. Joint Committee, and an allowable tension in the extreme top fiber of:
 (a) 0.04fc at time of transfer
 (b) 0.04fc under final dead & live load conditions
 Loading: A.A.S.H.O. H20-S16-44.
 No allowance has been made for wearing surface.

MATERIALS

Prestressing steel is to conform to the requirements of A.S.T.M. specification A421-S&T (Tensile strength 250,000 p.s.i.)
 Mild steel reinforcing is to conform to the requirements of C.S.A. Specification G30.1 for intermediate grade reinforcing.
 Mild steel reinforcing is to be deformed in accordance with the requirements of C.S.A. Specification G30.6.
 The stringer concrete is to have a cylinder strength of 4000 p.s.i. before the prestressing force is transferred.
 Concrete to have a 28 day strength of 6000 p.s.i.
 Maximum size of aggregate to be 3/4".
 Stress-Strain Curves: A copy of the manufacturers stress-strain curve for each lot of prestressing steel used and the location of each lot used, shall be supplied to the Dept.

FABRICATION

All acute corners on skewed girders to have 3/4" chamfer.
 Concrete test cylinders shall be tested by an independent testing laboratory, copies of all test results shall be forwarded to the Bridge Branch.
 Tests shall be taken at the rate of one cylinder each two stringers with not less than two cylinders for each day's pouring.

Construction procedures are to comply with chapter 4 of the A.C.I.-A.S.C.E. Joint Committee Recommendations.
 Stringers are to be constructed under the direction of a qualified Engineer.
 Initial jack forces shall be 1/12 strand for the top strands and 12 1/2 / 1/8 strand for the bottom strands.

Exterior face of exterior stringer to be finished to a smooth, hard uniform color and texture, dense surface finish, other surfaces to have all pockets filled and all fins removed.

Stringer Marks - Each stringer shall be marked with a number, 3" high and 1/2" deep, cast in the bottom of the stringer 6" from one end. Stressing data shall be supplied for each stringer, and where applicable, the lot of prestressing steel shall be indicated on the stressing data sheet.

NOTE: STRINGER TO BE LIFTED IN ACCORDANCE WITH THE REQUIREMENTS OF DWG. S 760

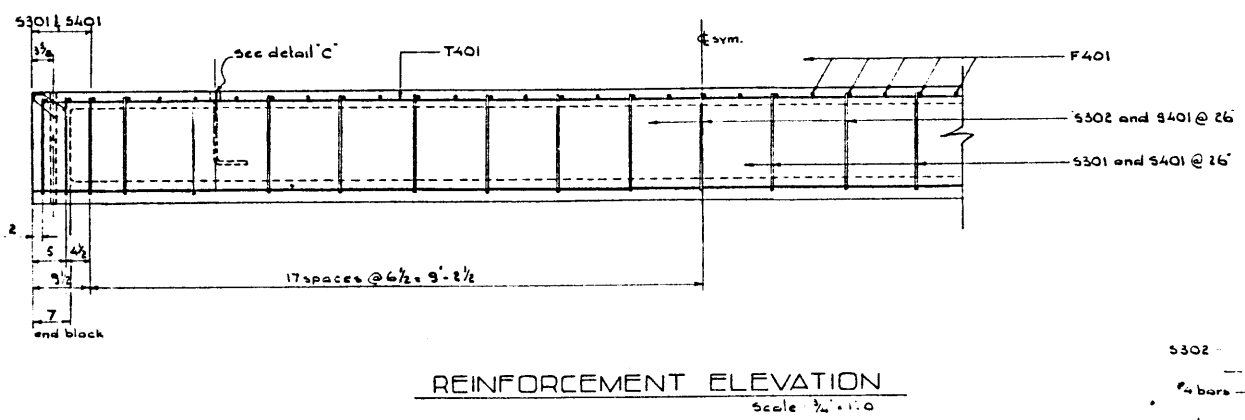
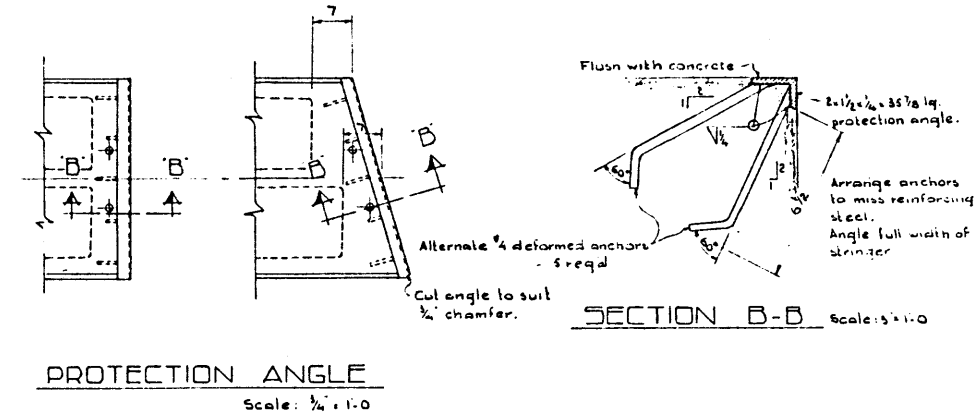
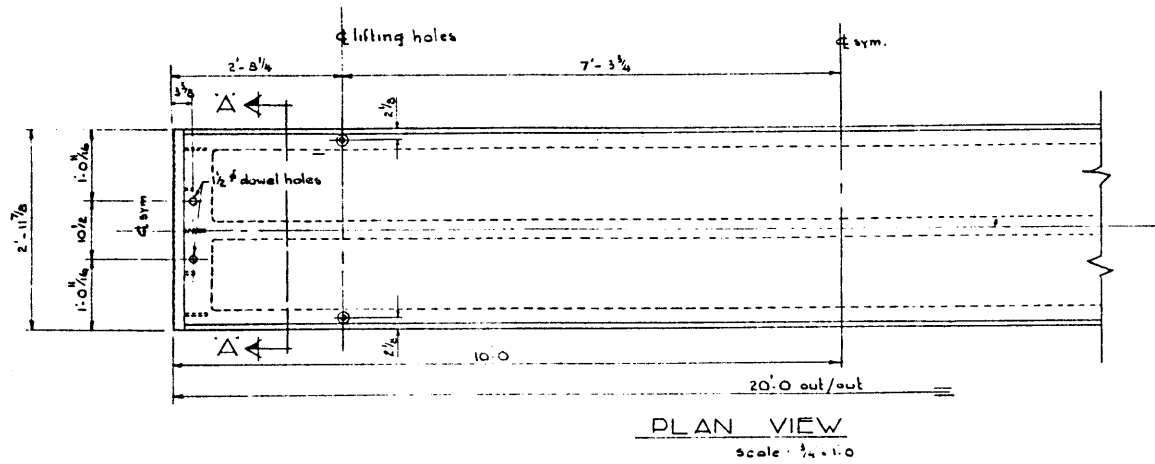

BAR LIST

Mark	Size	Number	Type	X	Length	Weight
S301	3	14	A		6'-3"	33
S302	3	12	B		2'-1 3/4"	15
S401	4	23	C		2'-1"	32
F401	4	37	Str		2'-9"	72
T401	4	2	Str		19'-8"	26
					Total	178 lb

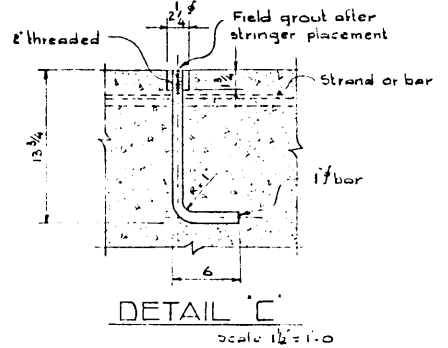
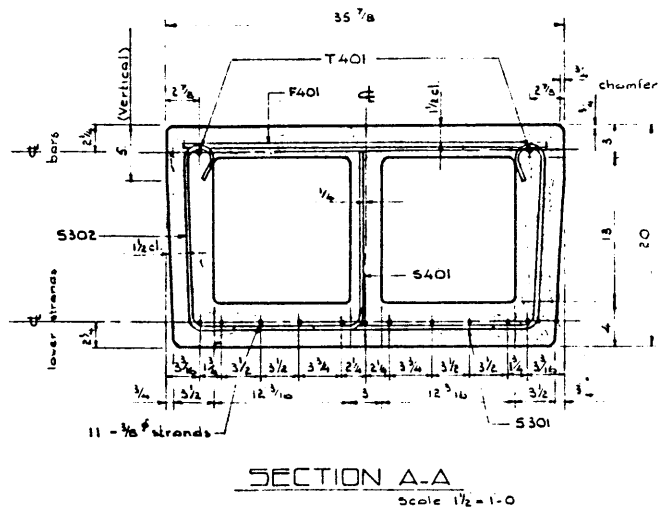
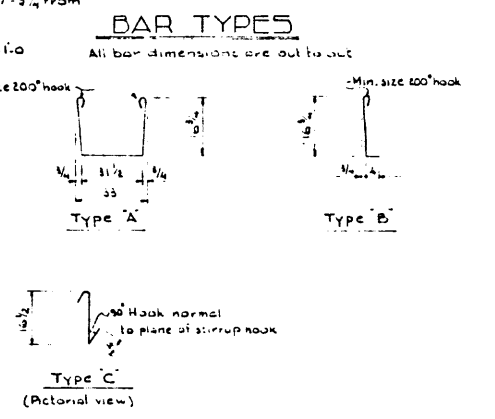
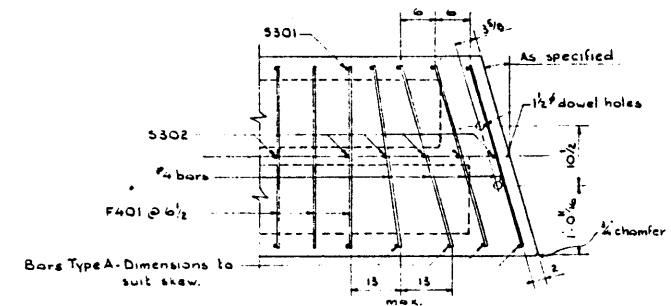

DESIGNED BY: R.P.P.
 CHECKED BY: R.E. Leimbach
 DATE: Apr-11-61

REVISIONS

NO.	DATE	DESCRIPTION	BY

PRESTRESSED CONCRETE
20 FT. SPAN
TYPE 'J' STRINGER

GOVERNMENT OF THE PROVINCE OF ALBERTA
 DEPARTMENT OF HIGHWAYS
 BRIDGE BRANCH, EDMONTON

FILE NO. _____ HWY. NO. _____ DWG. NO. **5748**
 LOCATION SCALE shown
 STREAM SHEET 1 OF 1