

Turning Movement Summary Diagram

Reference No.: 123160

Intersection of:
1 & 542 E OF BROOKS

2017 AADT / ASDT ESTIMATES

North On TwpRd 190C			
Vehicle Type	Vol	%	
A: Passenger Vehicle	1422	85.7	
B: Recreational Vehicle	23	1.4	
C: Bus	38	2.3	
D: Single Unit Truck	94	5.7	
E: Tractor Trailer Unit	83	5.0	
ASDT	1900	AAADT	1660

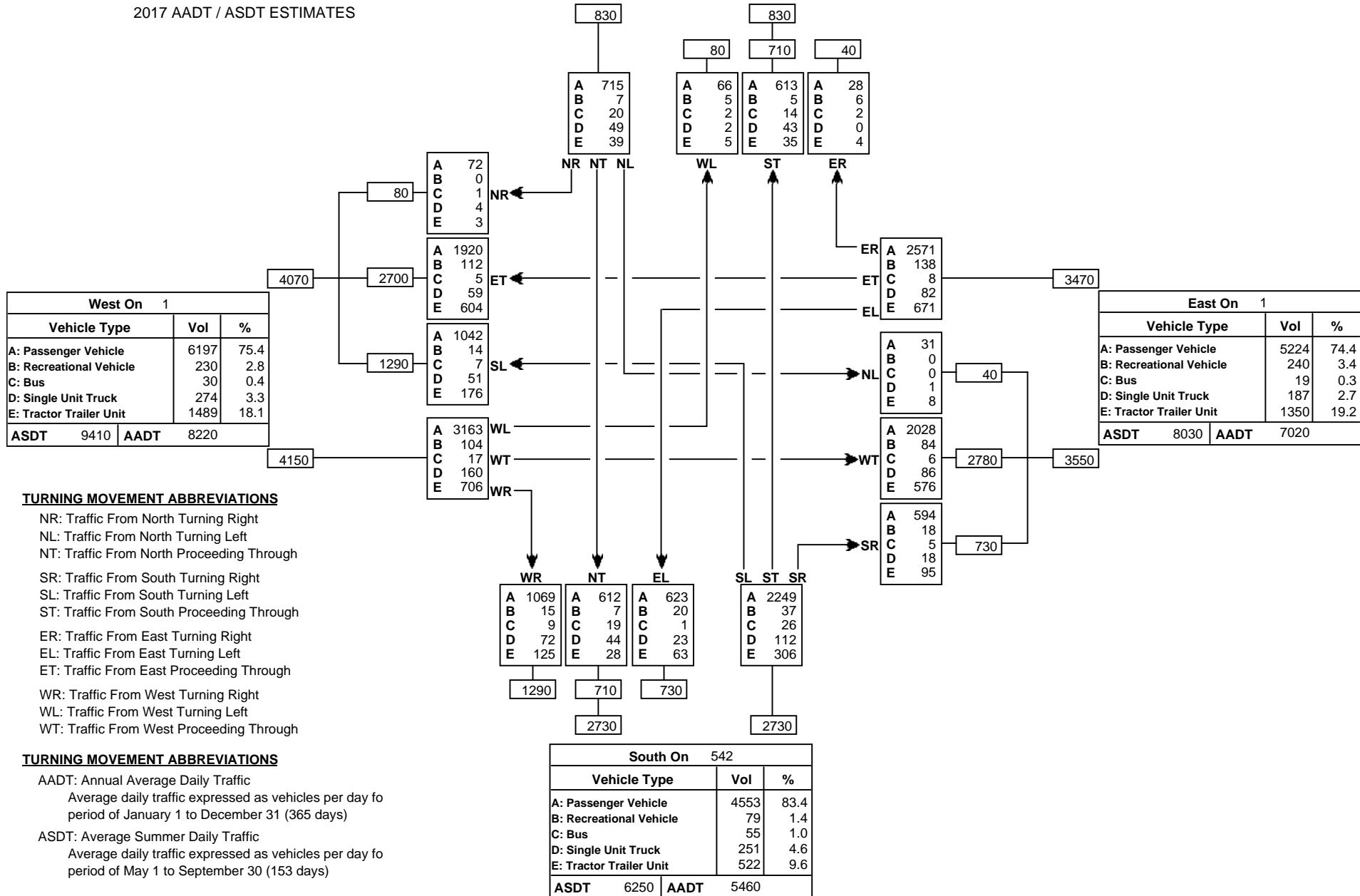

Turning Movement Summary Diagram

Reference No.: 123160

Intersection of:
1 & 542 E OF BROOKS

2017 a.m. 100th Highest Hour ESTIMATES

North On TwpRd 190C		
Vehicle Type	Vol	%
A: Passenger Vehicle	139	85.8
B: Recreational Vehicle	4	2.5
C: Bus	2	1.2
D: Single Unit Truck	8	4.9
E: Tractor Trailer Unit	9	5.6
Total	162	

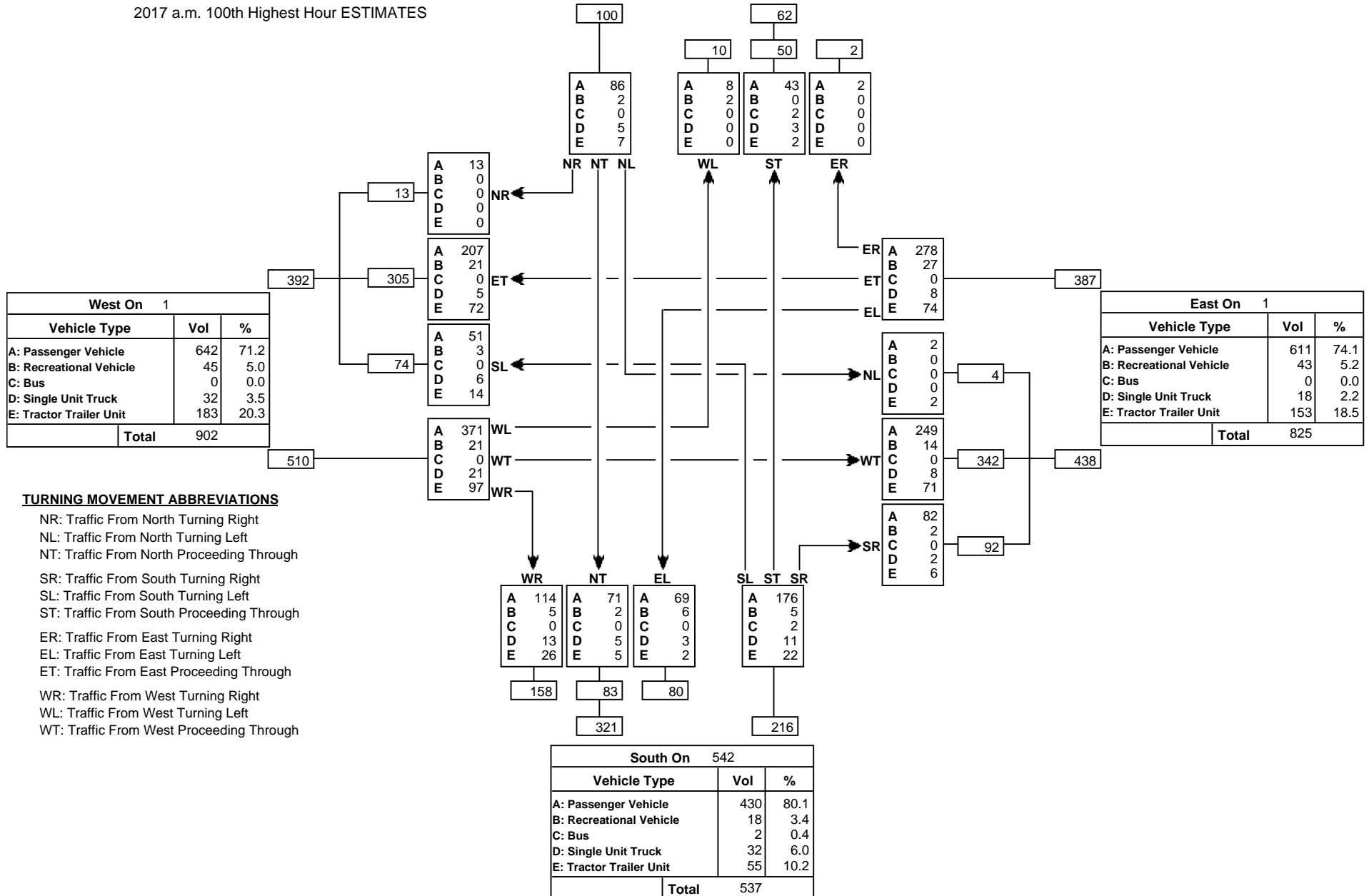

Turning Movement Summary Diagram

Reference No.: 123160

Intersection of:
1 & 542 E OF BROOKS

2017 p.m. 100th Highest Hour ESTIMATES

North On TwpRd 190C		
Vehicle Type	Vol	%
A: Passenger Vehicle	126	88.1
B: Recreational Vehicle	0	0.0
C: Bus	8	5.6
D: Single Unit Truck	1	0.7
E: Tractor Trailer Unit	8	5.6
Total	143	

West On 1		
Vehicle Type	Vol	%
A: Passenger Vehicle	729	80.9
B: Recreational Vehicle	23	2.6
C: Bus	3	0.3
D: Single Unit Truck	21	2.3
E: Tractor Trailer Unit	125	13.9
Total	901	

East On 1		
Vehicle Type	Vol	%
A: Passenger Vehicle	494	76.6
B: Recreational Vehicle	30	4.7
C: Bus	3	0.5
D: Single Unit Truck	12	1.9
E: Tractor Trailer Unit	106	16.4
Total	645	

South On 542		
Vehicle Type	Vol	%
A: Passenger Vehicle	545	86.9
B: Recreational Vehicle	7	1.1
C: Bus	8	1.3
D: Single Unit Truck	14	2.2
E: Tractor Trailer Unit	53	8.5
Total	627	

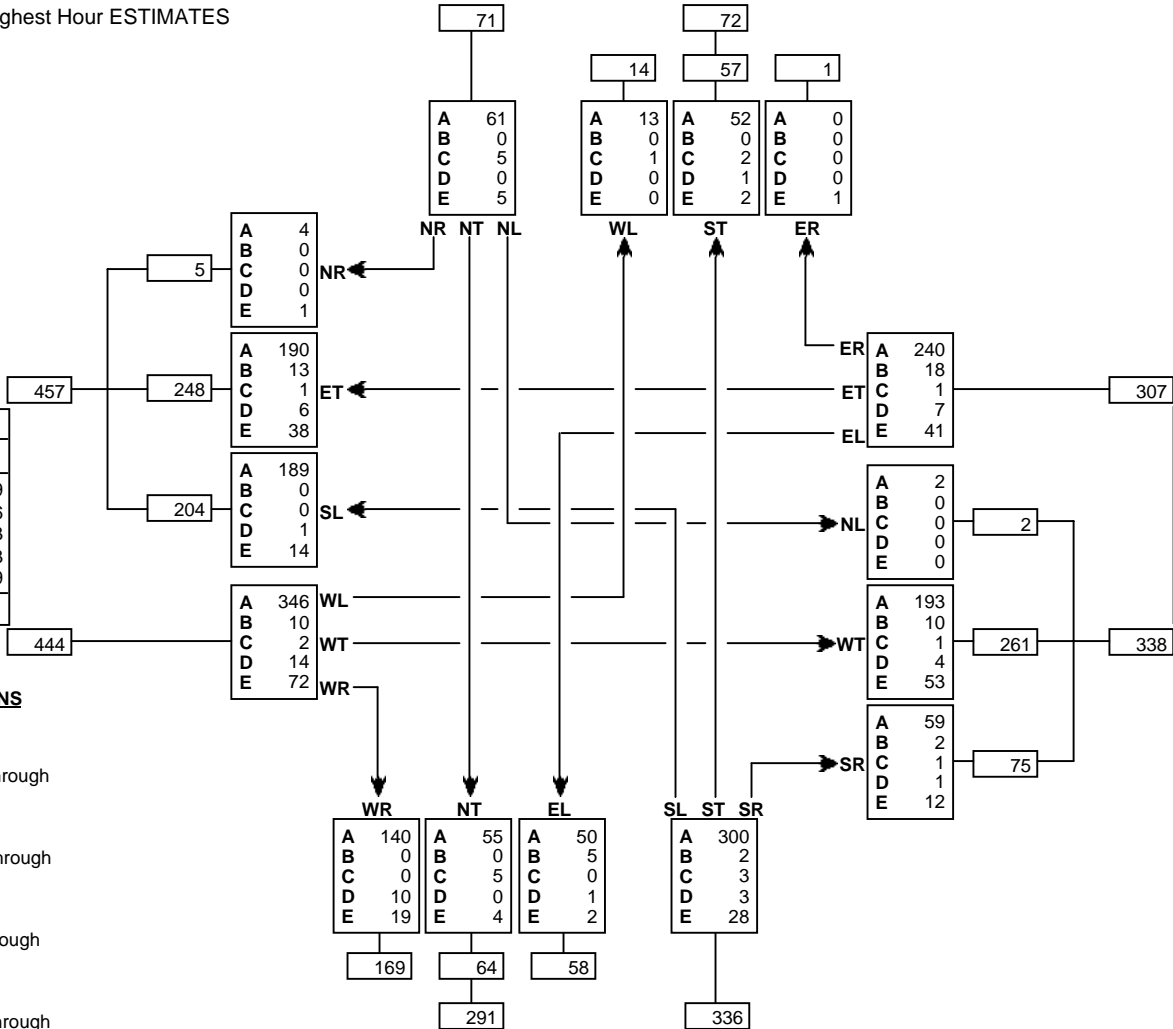

TURNING MOVEMENT ABBREVIATIONS

- NR: Traffic From North Turning Right
- NL: Traffic From North Turning Left
- NT: Traffic From North Proceeding Through
- SR: Traffic From South Turning Right
- SL: Traffic From South Turning Left
- ST: Traffic From South Proceeding Through
- ER: Traffic From East Turning Right
- EL: Traffic From East Turning Left
- ET: Traffic From East Proceeding Through
- WR: Traffic From West Turning Right
- WL: Traffic From West Turning Left
- WT: Traffic From West Proceeding Through